

SEANETTE CORKILL and ANNE MARIE LUTHRO

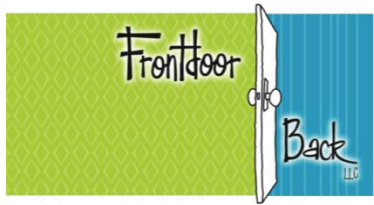

CELL: 360.281.3853

EMAIL: SEANETTE@FRONTDOORBACK.COM

WEB: FRONTDOORBACK.COM

DATE: December 22, 2022

SITE VISIT: Wednesday, November 16, 2022

CLIENT: **Colima Market**, Bend, OR

PROJECT: Storefront Consultation Summary

OBJECTIVE: Summary of top-level observations and recommendations following a 1-hour on-site consultation

COLIMA MARKET

December 2022

Yamely,

Thank you so much for participating in the storefront consultation provided by the City of Bend and Bend Chamber of Commerce. We appreciate that you have an eye on your future growth and that you're making your store the best it can be.

We have summarized our observations and recommendations on pages 3 through 6 for our **Tier-I** report. Tier-I reports put in writing our top 5 +/- recommendations for improving a store's façade. We did, however, veer into providing some creative direction that would have been reserved for a Tier-II report in pages 7 through 18. We couldn't help ourselves as words alone couldn't convey our aspirations for your store.

At another time we would love to revisit providing recommendations for your interior to improve the shopping experience for your existing and your NEW first-time shoppers. You have a great foundation to build upon.

In the meantime, if you have questions about anything in the report or want to discuss further consultation, please call or email. We are excited to share our ideas with you and look forward to seeing what you take action on.

Warmest regards,



seanette@frontdoorback.com
360-281-3853

annemarie@frontdoorback.com
503-407-1979

COLIMA MARKET

December 2022



While the specific goal of noticeability (particularly to attract a new, American customer base) is foremost, the overarching goal for the Colima Market is to present a refreshed, more polished appearance. As it exists now, the market is easy to miss from the street. Its neighbor, the bookstore, has created a beautiful, attention-grabbing façade with its storefront mural which currently, most likely, serves as a “look for the mural...” or “turn in at the mural...” landmark. But, because the mural is not lighted at night, while noticeable, it’s not a reliable, 24/7 landmark.

With the addition of new signage, color, possibly some dimensional features and of course, lighting to the façade of Colima Market, it will serve as its own 24/7 beacon, directing eyes and cars on its own strength. The following pages provide design directives to address our topmost concerns about the façade’s aspects that are underperforming.

COLIMA MARKET

December 2022



Day and evening views were taken into consideration. Shoppers experience both at different times of the year so any solutions we provide should address the 24/7 character of the storefront.



We have identified the following specific façade design shortcomings to address:

- **Signage:**
The existing storefront signage is an unlit, temporary banner. The sign itself contains font and graphics that are unique and thereby inconsistent with any other signage/graphics.
- **Lighting:**
Only one light appears to be functioning on the storefront. That light, to the left of the entry, a “pack light” is not the correct type of fixture or bulb/lamp. This light is relied upon to serve too many purposes and is not excelling at any.
- **Architectural Dimension and Interest:**
The cinderblock building lacks any architectural detail or color story to add character or attract the eye.
- **Food Truck:**
The food truck, which is a draw on its own and therefore an asset to the Market, doesn’t add any visual value to the Market.
- **Monument Sign:**
Given the absence of stronger signage on the building itself, it appears there is reliance on the monument sign which is overshadowed by the mural in the background. Graphics are not aligned with anything found on the building and difficult to comprehend. It is also not internally illuminated.
- **Window Signage:**
Category lettering occurring in three different colors within one word makes it difficult to comprehend its meaning. Large format graphics effectively hide the interior but do not obscure the aspects in the lower quarter of the openings that contribute the most to the visual clutter they are attempting to hide.
- **Door Signage:**
The correct content is located on the door (name, hours, etc.) but lacks polished execution and is at the wrong scale to be as legible as needed.

COLIMA MARKET: Recommendations

December 2022

Based upon our evaluation of areas for improvement we suggest taking the following corrective actions:

- **Signage:**
Work with a graphic artist to create one, consistent brand look and feel. Install a permanent sign. Position the sign more centrally within the full storefront keeping in mind that it should be visible from the street.
- **Lighting:**
Remove the two existing wall packs on the storefront. Install multiple forms of light; Signage; Pathway, Architectural and Ridgeline to support visibility during hours of darkness, safe and pleasant navigation on-site, define and promote the building and the business to passersby in a responsible, effective enjoyable manner.
- **Architectural Dimension and interest:**
Add color at a minimum to bring positive attention to the storefront. Whether it be an awning or covered entrance or applied trim details, explore added dimension to support the brand look. Creating a portico type awning over the entrance is one option that will add character to the store as well as provide shelter to those entering and exiting. This portico could support a tiled roof, further adding interest to the storefront that might align with a set of brand attributes.
- **Food Truck:**
Add café lights, strung from the truck over the picnic tables, to highlight and define the eating area. Café lights are synonymous with food/dining and will speak to drivers who are unaware the truck is tucked back into the parking lot. Further dress this area by installing fencing near the ends of the tables that will cordon off the area for a more protected, relaxed, polished eating area.
- **Monument Sign:**
Align graphics with the refreshed brand protocols. Repair internal illumination if possible. Keep in mind signage code directives on color values for internally illuminated signage graphics and lettering.
- **Window Signage:**
Rather than calling out specific categories with signage on the window treatment, pull this information up, onto the building where it too can be read from the street. Apply a dark opaque film to the lower panels of the windows. Treat the unused door in the window set to the left (south) of the entryway as a window and apply the large-format imagery to this glass as well. Apply the same film as used in the lower window panels to the lower ¼ of the door to further visually camouflage its nature and tie it in with the windows.
- **Door Signage:**
Create a blank slate by removing all existing decals, papers and signage. Reapply name and hours of operation in vinyl lettering per the brand graphics per the suggested protocols and hierarchies found in this report. Apply the vendor decal (Money transfer placard) where noted.

COLIMA MARKET: Examples and Inspiration

December 2022

1



1. This example shows assorted layers of light effectively illuminating the storefront for Chuck's Produce cinder block building. Both the signs and pathways have adequate light and decorative sconces are added to compliment the architectural story. The building has also received enhancements in the form of wood trim, posts and beams, stone veneers and other embellishments to add texture.

2



2. This stand-alone taqueria installed a slanted tile roof treatment along with a stone veneer around the bottom border of their building. Their color palette is handsome neutral light and dark tones. The arch of the front parapet adds interest and on-brand personality to the ridgeline.

3



3. The portico shown in this photo feels welcoming. The lanterns add ambiance during the day and soft lighting at night.

COLIMA MARKET

December 2022

A



This and the following page shows four traditional approaches to adding primary and category signage to the building front and lighting all of it where ever it is found.

On this page, the examples show signage, lighting which ties in with a covered entrance, thick decorative wood (or wood-looking) trim and a refreshed paint scheme to improve visibility and wayfinding.

The windows in all our examples stay similar to what is currently there but contain images of products ONLY. The bottom panes of glass receive an opaque film to block sightlines into back-of-house operations or unsightly storage.

The front door and adjoining window have been cleared. The treatment of this entrance area is addressed in later pages.

Concepts we didn't explore are murals such as a collage of pinatas or giant serape stripes. Signage placement would need to respond to the location of the graphics of course.

B



COLIMA MARKET

December 2022

C



The examples on this page would be less costly and require only signage, paint and lighting.

D



A cantilevered flat awning similar to the one in the photo above, wide enough to span both the window and door opening, may also be an option in the future for this design.

COLIMA MARKET

December 2022

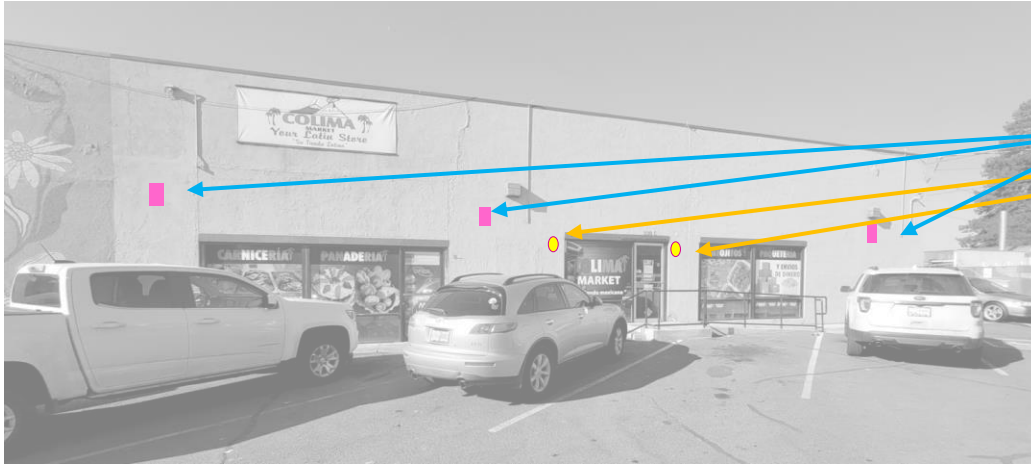

Cylinder downlight

Decorative Wall Sconce Options



Desired lighting outcomes of a cylinder downlight – a strong directed pool of light.

Regardless of the style of façade pursued, install downlights and decorative wall sconces within the wall sections of the storefront for safer and more enjoyable approaches to the front door.



COLIMA MARKET: Door Protocol

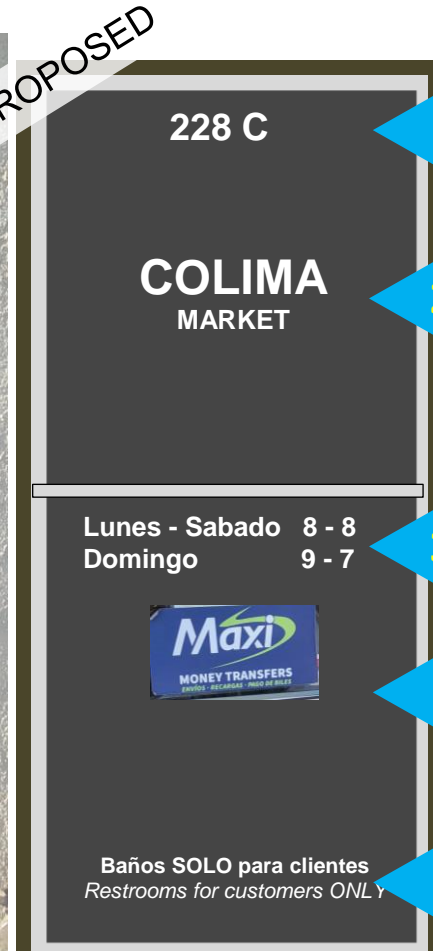

1. STORE ADDRESS – Replace existing metal numbers found affixed above the wood trim above the door (not shown in existing photo) with plain white vinyl numbers (check with code for minimum height ~ 4” or 6” tall) on the door. A number by itself is cleaner than a number with a square background field behind it. Do not purchase number decals at the hardware store.
2. STORE NAME– Updated logo and name should be placed at eye level. Convert any graphic elements that are dark colored to plain white so those elements will be visible.
3. STORE HOURS– Keep text as minimal as possible and in as few lines as possible. Place the days/hours of operation at or below waist-level. Start with Open hours/days and end with days you are Closed if any. This information needs to be readable from a parked car. This information does not need the header of "HOURS" as it is self-evident.
4. VENDOR DECAL– Use a tapeless sign holder to locate the decal on the door. Install 2 that are back to back so there is no blank backside visible when shoppers exit.
5. POLICY INFO– Keep policy information firm yet positive and avoid a NO or other negative phrasing.

- Start with clean, clear glass by removing all decals/stickers.
- All letters and numbers should be in **white** vinyl which ‘reads’ the strongest of any color against glass, which is perceived as a dark background.
- Never use tape to affix signage to glass.

COLIMA MARKET: Window Protocol

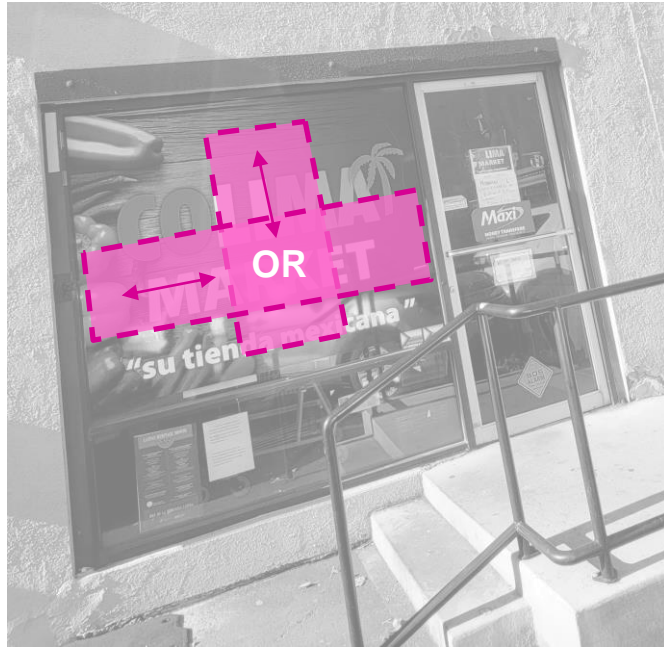

The larger top portion of the window adjacent to the front door should remain primarily clear. Shoppers at this point should be provided a view into the store. Managing what is visible from outside, of this interior entry area, will be key to setting the tone of what to expect inside.

Events and/or promotions could live (double sided of course) in the shaded pink area. The tapeless sign holders found in the reference area should be used to position posters and notices. Any material that does not fit in the dedicated, defined area should not be posted until a previous message has expired and is removed to make room for new.

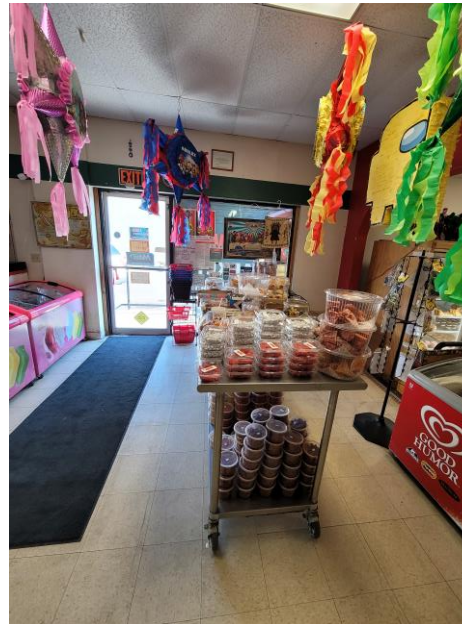

REFERENCES:

REFERENCES: Tapeless Signage Holder

Instead of tape when affixing information on windows or doors, this product offers an easy, flexible way to add and then easily reposition posters for events you choose to support.



Reusable Frame - 8.5"w x 11"h
1/2" Black Border 5/Pack

<https://www.magikframe.com/>

<https://stmdisplays.com/poster-sign-holders/magik-frame>

Also available in 11" x 17" and other sizes and orientations
Order with Black (recommended) 1/2" border clings

REFERENCES: Choosing a Gooseneck Fixture

- 1) **Style of shade** – 3 common shade styles illustrated
- 2) **Diameter of shade** - sizes (10" to 16") differ between manufacturers
- 3) **Arm bend** – is dependent upon site conditions and location of sign relative to the light's mounting base. Multiple styles and sizes of arm bends are available.
- 4) **Knuckle** accessory– assists in aiming light onto the sign if the arm bend and size limits proper illumination
- 5) **Controls** – Timers or sensors that operate the lights independently from the interior lights



You'll need to research where, within the building, you can bring power to the exterior. Ideally power would come from within the building for each light but you may need to surface-mount conduit to power the lights. If surface mount conduit is the best course of action, camouflage it by painting it to match its background.

Which style of gooseneck arm and shade works best? It depends. I recommend choosing the shade first and then the style of arm bend to suit the location's constraints and the personality you want it to have.

The shade should not block the view of the sign graphics or lettering and the arm should locate the light high enough above the lettering to have the light reach, not miss, the target.

Regardless of the gooseneck fixture, install a PAR style LED light (likely a PAR20 or PAR30 size) in 2700K.

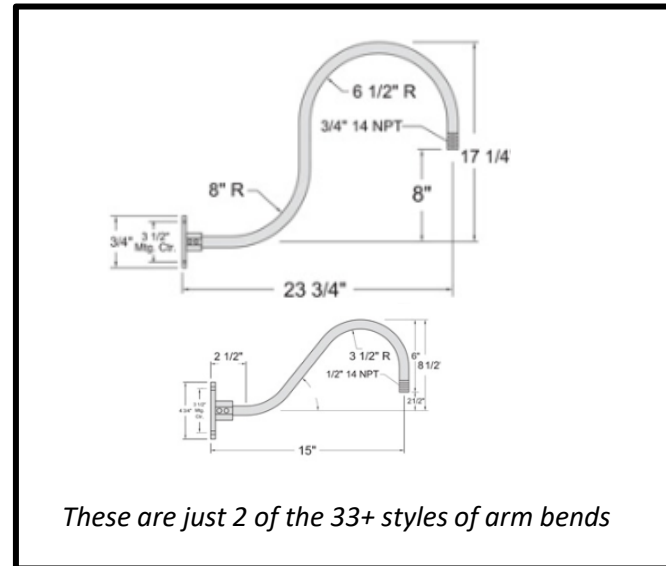

REFERENCES: Commercial LED Light Bulbs for Retail Use

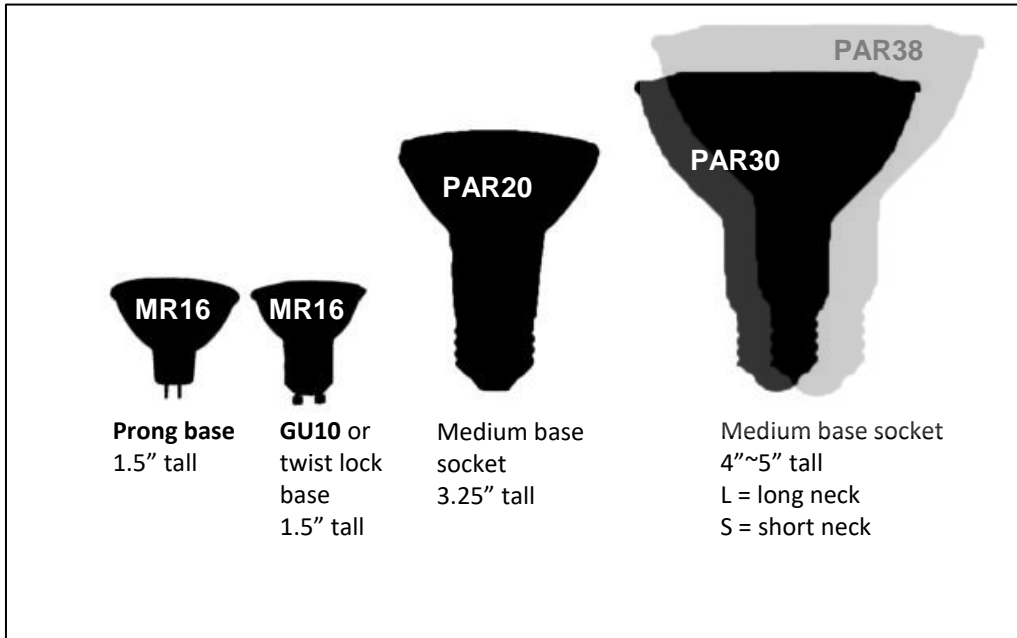

STYLE / DIAM

PAR (short for parabolic aluminized reflector) is the previous name for the style of the lens that is needed. PAR style bulbs typically have flat fronts and send out a focused beam of light.

"16" or "20" or "30" refer to the diameter of the face of the lens (bigger # = wider face)

High Ceiling: PAR30 or PAR 38

Low Ceiling: PAR20

Close to products: MR16

AVOID frosted and domed or bulb lenses

COLOR / APPEARANCE

The **Kelvin** number refers to the appearance of the color of the 'white' light ranging from warm to cool.

CRI (Color Rendering Index) indicates how true the colors of the product appear under a particular bulb.

Kelvin: 2700K or 3000k
CRI: 90 or greater

LUMENS

Lumens is the volume of light being emitted by the LED bulb. (Old terminology related to output for incandescent and halogen bulbs was watts). Watts was and is simply the energy being used.

OLD equivalency	NEW
100 watts	1600 lumens (16-18w)
75 watts	1100 lumens (13w)
60 watts	800 lumens (9-10w)
40 watts	450 lumens (6w)

BEAM SPREAD

Spread refers to the size and shape of the light beam coming from the bulb. It is expressed numerically in degrees of angles or with adjectives such as "spot" or "flood". Think of the beam of light like water coming out of a spray nozzle that you can adjust for a wide or narrow flow.

Spot and Narrow Spots
Flood and Narrow Flood

Choices depend on how far away the product is, lumens needed, size of the area needing light and the effect desired.

REFERENCES:

AVOID omni-directional light fixtures as shown below:



REFERENCES: Roller Shades



The photo above is of micro-weave roller shades. These shades allow people inside to see outside but when viewed from the outside looking in, if a black or charcoal colored fabric is used, trick the casual observer into thinking the view to the inside is still open (unobstructed) because the glass looks dark like it normally does.

There are plenty of ways to buy shades online [Blinds.com or TheShadeStore} but check first with local vendors for availability of brands they represent [Hunter Douglas for example]. They will measure, install and typically take care of any warranty issues better than online companies. If you are installing these inside your display windows, it may be worth the added expense to have remote controlled motorized shades so you don't have to disturb the display to raise and lower the shades. Your provider will help you determine and measure for whether to use an inside-the-frame mount or surface mount.

The shade fabric is described by the percent of light it allows in. Something that blocks the sun completely is 0% see-through versus a fabric that allows some sun (such as a 5% see-through fabric as shown above).

Budget an average cost of \$67 per linear foot (tax, shipping and installation included in that figure). This cost is based upon prices encountered during multiple projects in the Pacific Northwest in 2019 – 2020. Of course, there's been inflationary price increases since then and every market is different.