

#3 BARS, PROJECT 18" INTO CONCRETE GUTTER PAN (BEND TO MATCH GUTTER PAN. SEE SECTION B-B)

PLAN VIEW

WET SET RISER INTO GROUT PER SECTION 00470.42 (SEE KEYWAY DETAIL BELOW)

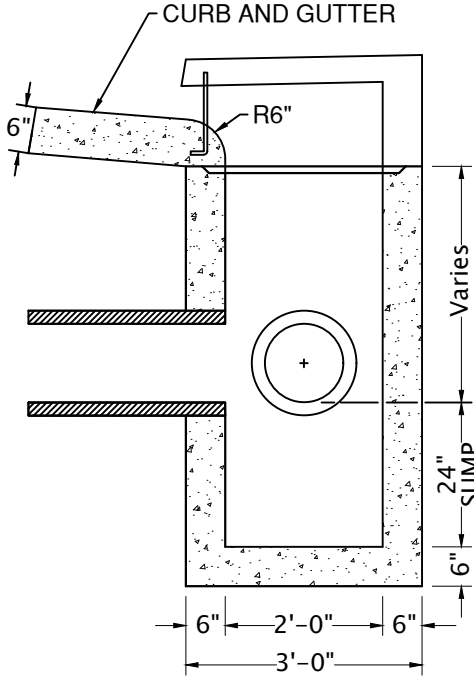

SECTION B - B

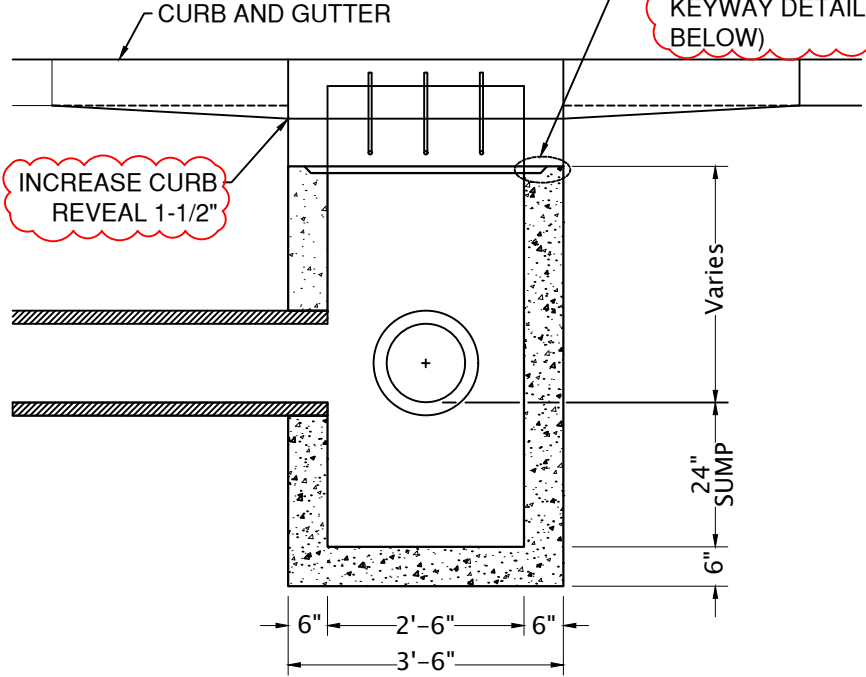

SECTION A - A

NOTES:

1. REMOVE SUFFICIENT CURB TO POUR BACK WALL. TOP SECTION MAY BE POURED MONOLITHIC WITH SIDEWALK.
2. CURB INLETS TO BE USED ON ARTERIAL AND COLLECTOR ROADWAYS.
3. "E" = CURB EXPOSURE.
4. SEE COB STD DWG STRM-8 FOR CAST IRON MANHOLE ADJUSTMENT RING AND COVER.
5. ALL PIPE CONNECTIONS TO BE GROUTED PER SPECIFICATION SECTION 00470.40.

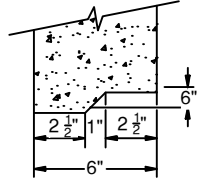

KEYWAY DETAIL

DRAWN AJD	
DIV STORM	
REV	DATE



CITY OF BEND
STANDARD DRAWING
710 NW WALL ST., BEND, OREGON 97701

STANDARD CURB INLET

SCALE NTS
DATE 11/01/2024
APPR
STD DWG STRM-9