

# DESCHUTES BUNGALOW

PROJECT ADDRESS

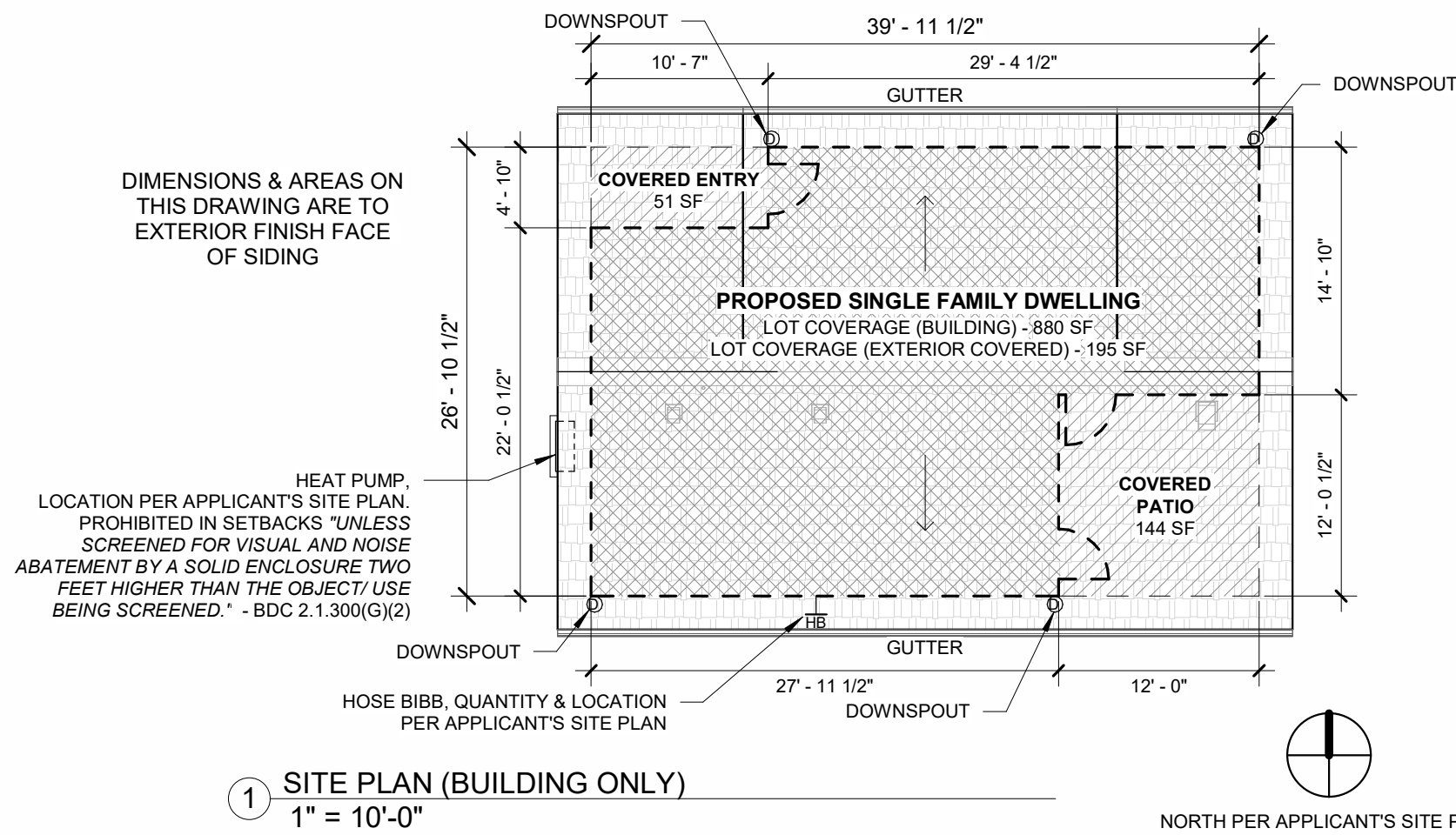

## SITE GENERAL NOTES

- ALL STORMWATER DRAINAGE TO BE MAINTAINED ON SITE. APPLICANT'S SITE PLAN TO ILLUSTRATE SITE SPECIFIC METHODS.
- LOTS SHALL BE GRADED TO DRAIN SURFACE WATER AWAY FROM NEW FOUNDATION WALLS. "THE GRADE SHALL FALL NOT FEWER THAN 6" WITHIN THE FIRST 10'. WHERE LOT LINES, WALLS, SLOPES OR OTHER PHYSICAL BARRIERS PROHIBIT 6" OF FALL WITHIN 10', DRAINS, SWALES, OR OTHER MEANS SHALL BE PROVIDED AND SHALL BE CONSTRUCTED TO ENSURE DRAINAGE AWAY FROM THE STRUCTURE."
- IMPERVIOUS SURFACES WITHIN 10' OF THE BUILDING FOUNDATION SHALL BE SLOPED NOT LESS THAN 2 PERCENT (1/4" PER FOOT) AWAY FROM THE BUILDING.
- THESE MASTER REISSUE DRAWINGS ARE ONLY FOR USE ON SITES THAT DO NOT EXCEED 2' SLOPE ACROSS THE SITE AT THE FOOTING AND SITES WITH TYPICAL LOCAL GEOLOGICAL CONDITIONS.

## ABBREVIATIONS

A.F.F.	ABOVE FINISH FLOOR
ALUM.	ALUMINUM
B.O.	BOTTOM OF
CAB.	CABINET
C.J.	CONTROL JOINT
C.L.	CENTER LINE
CLR.	CLEAR
COL.	COLUMN
CONC.	CONCRETE
CONT.	CONTINUOUS
CPT.	CARPET
C.T.	CERAMIC TILE
DBL.	DOUBLE
DF-L	DOUGLAS FIR - LARCH
DIA.	DIAMETER
DIM.	DIMENSION
D.M.C.	DOOR MANEUVERING CLEARANCE
DN.	DOWN
DW	DISHWASHER
EA.	EACH
E.J.	EXPANSION JOINT
EWf	ENGINEERED WOOD FLOORING
ELEC.	ELECTRICAL
E.O.S.	EDGE OF SLAB
EQ.	EQUAL
(E)	EXISTING
E.J.	EXPANSION JOINT
EXT.	EXTERIOR
FLR.	FLOOR
F.F.	FINISH FACE OR FINISH FLOOR
F.F.E.	FINISH FLOOR ELEVATION
F.O.S.	FACE OF STRUCTURE / STUD
GLB	GLUE LAMINATED BEAM
G.W.B.	GYPSTUM WALL BOARD
INSUL.	INSULATED OR INSULATION
INT.	INTERIOR
LVP.	LUXURY VINYL PLANK
MAX.	MAXIMUM
MECH.	MECHANICAL
M.E.P.	MECHANICAL, ELECTRICAL & PLUMBING
MFR.	MANUFACTURER
MIN.	MINIMUM
N.F.V.A.	NET FREE VENTILATION AREA
N.I.C.	NOT IN CONTRACT
NOM.	NOMINAL
N.T.S.	NOT TO SCALE
O.C.	ON CENTER
P.T.	PRESSURE TREATED
PTD.	PAINT OR PAINTED
RCP	REFLECTED CEILING PLAN
REC.	RECOMMENDED
REF.	REFRIGERATOR
REQ.	REQUIRED
R.O.	ROUGH OPENING
R.O.W.	RIGHT OF WAY
S.F.	SQUARE FEET
SHGC	SOLAR HEIGHT GAIN COEFFICIENT
IN <sup>2</sup>	SQUARE INCHES
SIM.	SIMILAR
SPEC.	SPECIFIED OR SPECIFICATION
SSTL.	STAINLESS STEEL
S.T.C.	SOUND TRANSMISSION CLASS
S.W.	SHEAR WALL
T&G	TONGUE AND GROOVE
T.O.	TOP OF
T.P.D.	TOILET PAPER DISPENSER
TYP.	TYPICAL
U.N.O.	UNLESS NOTED OTHERWISE
VERT.	VERTICAL
V.I.F.	VERIFY IN FIELD
W/	WITH
W/O	WITHOUT
W/D	CLOTHES WASHER & DRYER
WD.	WOOD
W.R.B.	WEATHER RESISTANT BARRIER

## PROJECT SYMBOLS

	NORTH ARROW
	EXTERIOR ELEVATION
	INTERIOR ELEVATION
	BUILDING SECTION
	ENLARGED PLAN / DETAIL
	BUILDING ASSEMBLY TYPE
	DOOR TAG
	WINDOW TAG
	REVISION TAG
	CENTER LINE

## PLANNING & CODE SUMMARY

### APPLICABLE CODES

2023 OREGON RESIDENTIAL SPECIALTY CODE (ORSC)  
2022 OREGON MECHANICAL SPECIALTY CODE (OMSC)  
2023 OREGON ELECTRICAL SPECIALTY CODE (OESC)  
2023 OREGON PLUMBING SPECIALTY CODE (OPSC)  
BEND DEVELOPMENT CODE

### CONSTRUCTION TYPE

TYPE V-B, NON SPRINKLED

### SETBACKS\*

RL (LOW DENSITY RESIDENTIAL)  
FRONT 20', REAR 20', SIDE 10'  
RS (STANDARD DENSITY RESIDENTIAL)  
FRONT 10', REAR 5', SIDE 5'  
RM-10, RM & RH  
FRONT 10', REAR 5', SIDE 5'

\*NORTH SOLAR SETBACK APPLIES TO SITES OVER 5,000 SF & NORTH - SOUTH LOT DIMENSION OVER 80'

SPECIAL SETBACKS & EASEMENTS  
APPLICANT TO VERIFY AND SHOW ON SITE PLAN

### MAXIMUM LOT COVERAGE

RL 35%  
RS & RM-10 45%-60%  
RM 45%-60%  
RH NONE

### FLOOR AREA RATIO

RL NONE  
RS & RM-10 1.1 FOR 3-STORY RESIDENTIAL USES & ACCESSORY STRUCTURES, NONE FOR ALL OTHER USES  
RM NONE  
RH NONE

### ENERGY - BUILDING ENVELOPE

CLIMATE ZONE - 5B (BEND) (ASHRAE STANDARD 169)  
ALL PROPOSED BUILDING ASSEMBLIES SHALL COMPLY WITH TABLE N1101.1(1) PRESCRIPTIVE ENVELOPE REQUIREMENTS OF THE 2023 ORSC.

### ADDITIONAL ENERGY MEASURE OPTIONS

TABLE N1101.1(2)  
#5 DUCTLESS HEAT PUMP (DWELLING UNITS W/ ALL-ELECTRIC HEAT)  
A) PROVIDE DUCTLESS HEAT PUMP OF MINIMUM HSPF 10.0  
B) PROVIDE PROGRAMMABLE THERMOSTAT FOR ALL HEATERS IN BEDROOMS

### WHOLE HOUSE VENTILATION

DWELLING UNIT FLOOR AREA <1,500 SF  
NUMBER OF BEDROOMS - 2  
REQUIRED MINIMUM CONTINUOUS CFM - 45 CFM

### SITE ACCESSIBLE ROUTE

THE APPLICANT IS RESPONSIBLE TO PROVIDE AN ACCESSIBLE ROUTE TO THE PROPOSED SINGLE FAMILY DWELLING IN COMPLIANCE WITH CHAPTER 4 OF THE 2017 ICC A117.1 AND "CHANGES IN LEVEL" DETAILS PER A7.0. (TYPE A)

## PROJECT DESCRIPTION

CITY OF BEND PRE-APPROVED SINGLE FAMILY DWELLING  
799 SF LIVING AREA (ADU ELIGIBLE)  
"TYPE A" ACCESSIBLE PER THE 2017 ICC A117.1

## PROJECT GENERAL NOTES

- DO NOT SCALE PRINTED DRAWINGS. DO NOT SCALE OFF DRAWINGS WITHOUT CONSULTING ARCHITECT FIRST.
- DIMENSIONS ARE TO FACE OF STRUCTURE (FRAMING, CONCRETE, ETC.) U.N.O. "CLEAR" OR "CLR" DIMENSIONS ARE TO FINISH FACE.
- PROJECTS UTILIZING THE MASTER/REISSUE PROGRAM ARE LIMITED TO THOSE THAT WILL BE CONSTRUCTED "EXACTLY" AS SHOWN ON THESE APPROVED "MASTER" APPLICATION PLANS AND LOCATED ON A SITE THAT DOES NOT EXCEED 2' SLOPE ACROSS THE SITE AT THE FOOTING OR REQUIRE MODIFICATIONS TO THE DESIGN CRITERIA OR BUILDING CONSTRUCTION.
- THESE PLANS COMPLY WITH "TYPE A" CRITERIA OF THE "2017 ICC A117.1 ACCESSIBLE AND USABLE BUILDINGS AND FACILITIES" AND HAVE BEEN CERTIFIED AS SUCH BY LIVEABLE HOMES LLC. OPTIONS LABELED "TYPE A" ARE REQUIRED IN ORDER TO MEET TYPE A CRITERIA. OPTIONS LABELED "NONE TYPE A" DO NOT MEET TYPE A CRITERIA.

## SHEET LIST

NUMBER	NAME
ARCHITECTURAL	
A1.0	GENERAL INFORMATION
A1.1	PROPOSED SITE PLAN, N.I.C. (APPLICANT TO PROCURE)
A1.2	FLOOR PLAN & SCHEDULES
A1.3	ROOF PLAN
A1.4	REFLECTED CEILING & ELECTRICAL PLAN (DEFERRED, AFTER PERMIT)
A2.1	EXTERIOR ELEVATIONS
A3.1	BUILDING SECTIONS
A3.2	BUILDING SECTIONS
A5.1	EXTERIOR DETAILS
A7.0	ACCESSIBILITY DETAILS
A7.1	INTERIOR - KITCHEN
A7.2	INTERIOR - BATHROOM & W/D
A9.1	3D VIEWS - EXTERIOR
A9.2	3D VIEWS - INTERIOR
STRUCTURAL	
S1	FOUNDATION
S2	SUBFLOOR FRAMING
S3	MAIN LEVEL FRAMING
S4	MAIN LEVEL LATERAL
S5	DETAILS

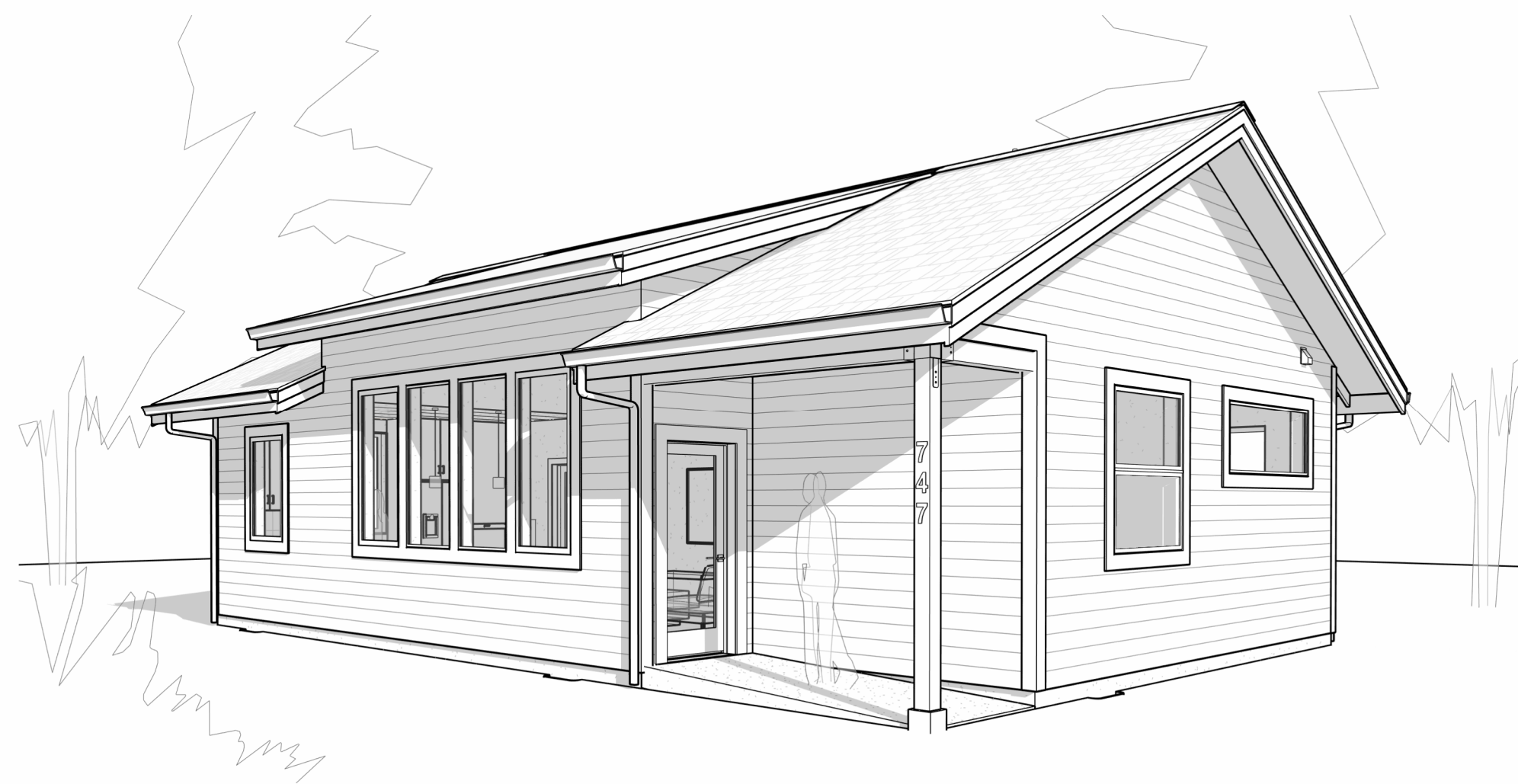

JURISDICTION APPROVAL

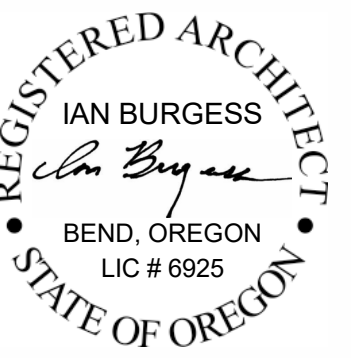

SIERRA JAMES



GENERAL INFORMATION

MASTER REISSUE PERMIT  
03/11/2026

DESCHUTES BUNGALOW

INFO@SIERRA-JAMES.COM

(541) 306-3775

PROJECT ADDRESS

A1.0

WINDOW SCHEDULE					
#	TYPE	SILL R.O.	WIDTH	HEIGHT	COMMENTS
01	CASEMENT	36"	36"	60"	
02	CASEMENT	36"	36"	60"	EGRESS
03	CASEMENT	36"	36"	60"	
04	CASEMENT	36"	36"	60"	
05	CASEMENT	40 5/8"	30"	60"	
06	CASEMENT	39"	36"	54"	
07	CASEMENT	39"	36"	72"	
08	FIXED	39"	36"	72"	
09	FIXED	39"	36"	72"	
10	CASEMENT	39"	36"	72"	
11	TOP AWNING	40 5/8"	54"	60"	FROSTED PRIVACY & SAFETY GLASS BOTTOM PANE ONLY
12	FIXED	70 5/8"	84"	30"	
Grand total: 12					

DOOR SCHEDULE				
#	OPERATION	WIDTH	HEIGHT	COMMENTS
Exterior THRESHOLDS TO COMPLY WITH "CHANGES IN LEVEL" DETAILS PER A7.0				
01	IN-SWING	36"	80"	ACCESSIBLE SILL PER 4/A5.1
02	OUT-SWING	36"	80"	EGRESS, ACCESSIBLE SILL PER 4/A5.1
03	36" OUT-SWING W/ 24" SIDELIGHT	60"	80"	ACCESSIBLE SILL PER 4/A5.1
Interior				
04	DOUBLE BIFOLD	48"	80"	
05	DOUBLE BIFOLD	48"	80"	
06	POCKET	36"	80"	PULL HANDLE PER A7.0
07	POCKET	36"	80"	PULL HANDLE PER A7.0
08	POCKET	36"	80"	PULL HANDLE PER A7.0
09	SWING	24"	80"	
10	SWING	28"	80"	

- ### WINDOW & DOOR GENERAL NOTES
- FRAMING SUBCONTRACTOR TO VERIFY ALL ROUGH OPENING DIMENSIONS WITH WINDOW & DOOR MANUFACTURERS BEFORE FRAMING BEGINS. WINDOW SCHEDULE SIZES ARE ROUGH OPENINGS AND DOOR SCHEDULE SIZES ARE NOMINAL DOOR SIZE, UNLESS NOTED OTHERWISE.
  - EXTERIOR DOORS TO BE U-0.20 OR LESS, EXCEPT A MAXIMUM OF 28 SF OF EXTERIOR DOOR AREA PER DWELLING UNIT CAN HAVE A U-FACTOR OF 0.54 OR LESS
  - WINDOWS TO HAVE A U-FACTOR OF 0.27 OR LESS
  - SKYLIGHTS TO HAVE A U-FACTOR OF 0.50 OR LESS
  - UNSHADED SOUTH AND WEST FACING GLASS TO HAVE A LOW SOLAR HEIGHT GAIN COEFFICIENT (SHGC)
  - WINDOWS TO BE INSTALLED PER AAMA 2400-21 METHOD A OR METHOD B USING BUTYL FLEXIBLE FLASHING TAPE, TYPICAL.
  - DOOR THRESHOLDS SHALL COMPLY WITH "CHANGES IN LEVEL" DETAILS PER A7.0
  - DOORWAYS SHALL HAVE A CLEAR OPENING WIDTH OF 32 INCHES MINIMUM. CLEAR OPENING WIDTH OF DOORWAYS WITH SWINGING DOORS SHALL BE MEASURED BETWEEN THE FACE OF DOOR AND STOP, WITH THE DOOR OPEN 90 DEGREES. THERE SHALL BE NO PROJECTIONS INTO THE CLEAR OPENING WIDTH LOWER THAN 34 INCHES ABOVE THE FLOOR. PROJECTIONS INTO THE CLEAR OPENING WIDTH BETWEEN 34 INCHES AND 80 INCHES ABOVE THE FLOOR SHALL NOT EXCEED 4 INCHES.
  - DOORS & WINDOWS TO MEET "OPERABLE PARTS" NOTES PER A7.0. RECOMMEND LEVER TYPE DOOR HANDLES THROUGHOUT.

- ### FLOOR PLAN GENERAL NOTES
- DIMENSIONS ON THIS SHEET ARE TO FACE OF STRUCTURE (STUD OR CONCRETE) AND CENTER OF OPENING / FIXTURE, U.N.O.
  - DIMENSIONS NOTED "F.F." ARE TO FACE OF FINISH. DIMENSIONS NOTED "CLEAR" OR "CLR" ARE TO FACE OF FINISH.
  - OVERALL ROOM DIMENSIONS ARE TO FINISH FACE OF WALL AND ROUNDED TO NEAREST INCH. DO NOT FRAME FROM THESE DIMENSIONS.
  - DEVIATION FROM THESE DRAWINGS MUST BE APPROVED BY THE CITY OF BEND, ARCHITECT OF RECORD AND ENGINEER OF RECORD.
  - SUBCONTRACTORS TO SIZE, SELECT AND VERIFY LOCATION OF ALL PROPOSED M.E.P. EQUIPMENT IN COMPLIANCE WITH LOCAL BEND DEVELOPMENT CODE AND STATE BUILDING CODES.
  - EXTERIOR WALLS ARE 2X6 STUDS @ 24" O.C., U.N.O.
  - INTERIOR WALLS ARE 2X4 STUDS @ 16" O.C., U.N.O.

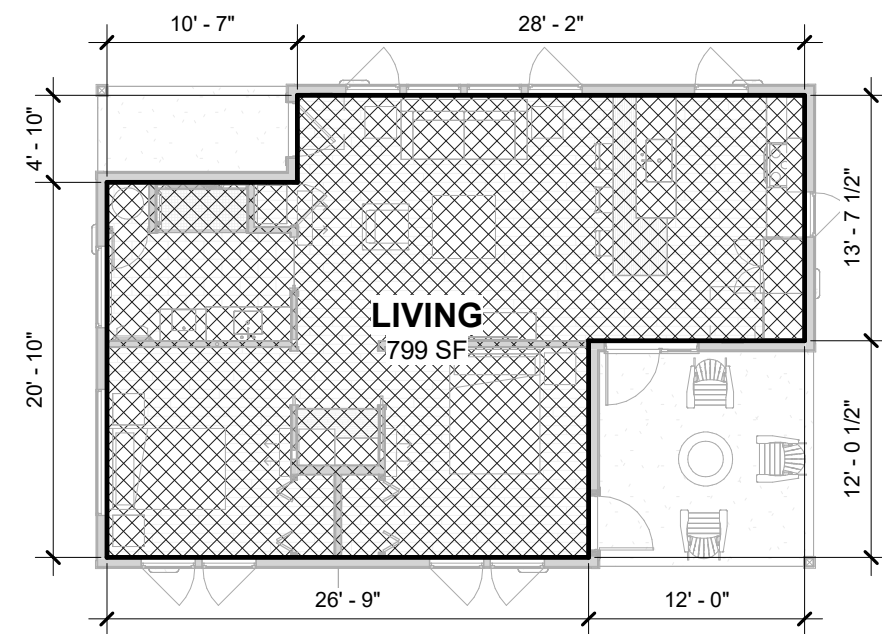

2 LIVING AREA PLAN  
3/32" = 1'-0"

FLOOR PLAN LEGEND	
	INTERCONNECTED SMOKE DETECTOR, HARD-WIRED W/ BATTERY BACKUP; CARBON MONOXIDE DETECTOR REQ'D WITHIN 15' OF ALL PROPOSED SLEEPING AREAS
	BATH EXHAUST FAN ON TIMER OR AUTOMATIC HUMIDISTAT SWITCH
	HOSE BIBB, FROST-PROOF W/ BACKFLOW PREVENTER, ALIGNED WITH PERPENDICULAR INTERIOR WALL. APPLICANT TO DEFINE LOCATION(S) & QUANTITIES ON SITE PLAN & WATER METER & SUPPLY SIZING WORKSHEET
	DOWNSPOUT
	WALL MOUNTED HEAT PUMP HEAD ABOVE

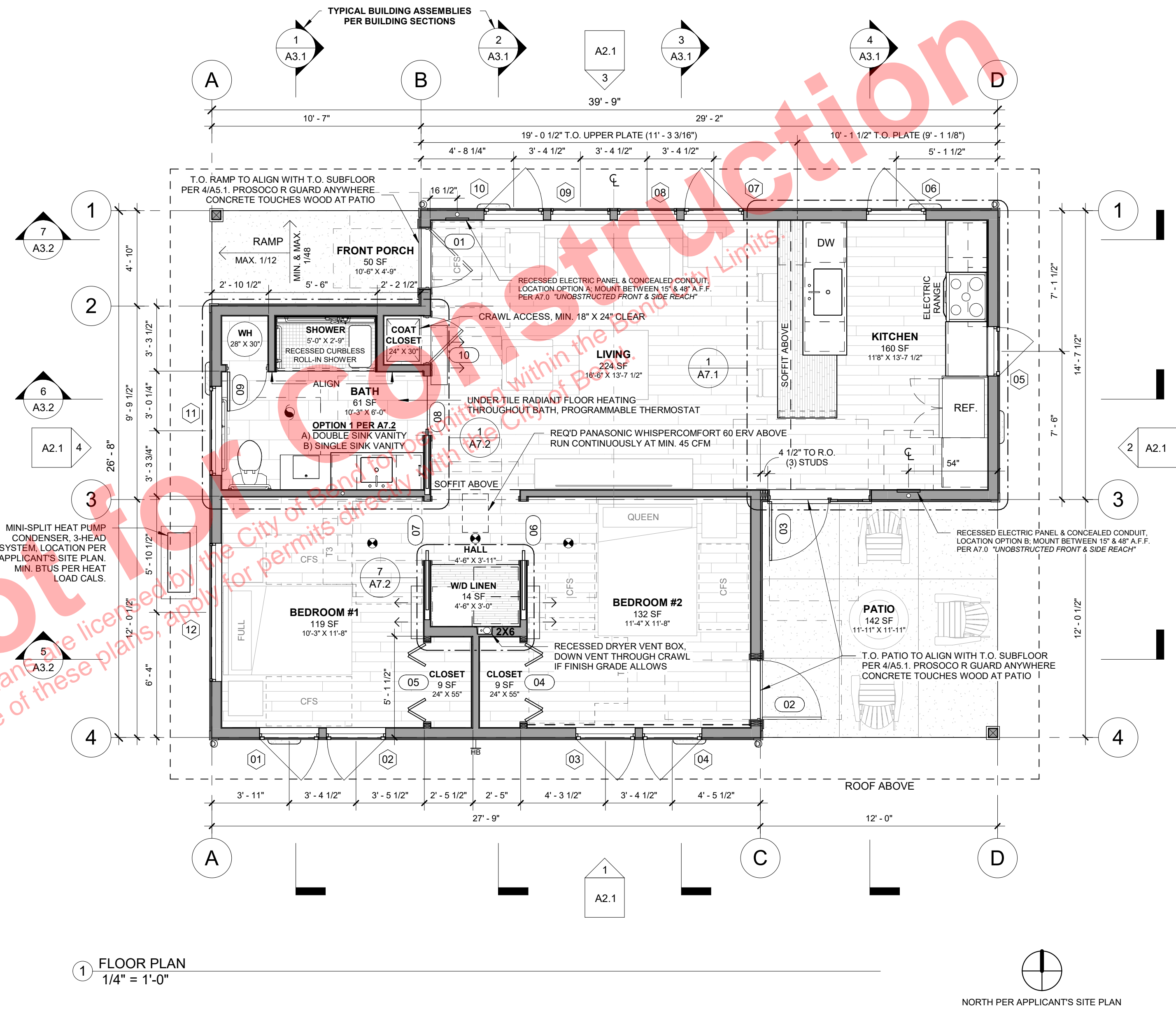

1 FLOOR PLAN  
1/4" = 1'-0"

JURISDICTION APPROVAL



FLOOR PLAN & SCHEDULES

MASTER REISSUE PERMIT  
03/11/2026

(541) 306-3775  
INFO@SIERRA-JAMES.COM

DESCHUTES BUNGALOW

PROJECT ADDRESS

A1.2



SIERRA JAMES



ROOF PLAN

MASTER REISSUE PERMIT  
03/11/2026

(541) 306-3775  
INFO@SIERRA-JAMES.COM  
**DESCHUTES BUNGALOW**

PROJECT ADDRESS

**A1.3**

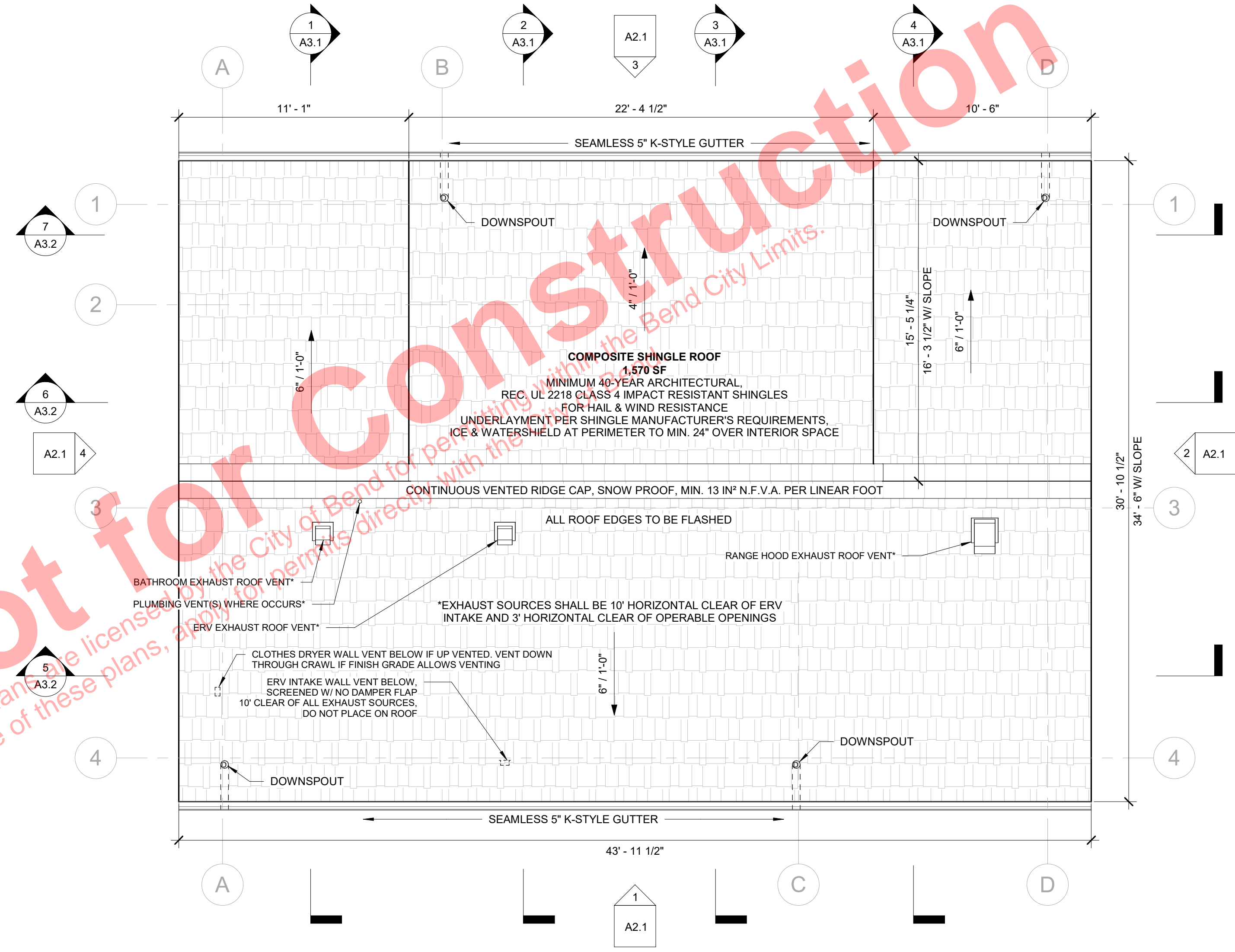

1 ROOF PLAN  
1/4" = 1'-0"



**EXTERIOR - GENERAL NOTES**

- 1) SILL DIMENSIONS ARE FROM T.O. SUBFLOOR TO B.O. ROUGH OPENING. WINDOW SHALL BE HUNG CENTERED IN OPENING.
- 2) WINDOWS TO BE INSTALLED PER AAMA 2400-21 METHOD A OR METHOD B USING BUTYL FLEXIBLE FLASHING TAPE. ALL EXTERIOR OPENINGS TO RECEIVE HEAD FLASHING W/ W.R.B. OVER FLASHING.
- 3) LOW EXPANSION FOAM TO BE INSTALLED CONTINUOUSLY ON ALL SIDES OF WINDOW & EXTERIOR DOORS.
- 4) ALL EXTERIOR CAULKING SEALANT TO BE EXTERIOR GRADE POLYURETHANE WITH MINIMUM 25%+ ELASTOMERIC PROPERTIES.

**TYPICAL NOTES**

- CONTINUOUS VENTED RIDGE CAP, MIN. 13 IN<sup>2</sup> N.F.V.A. PER LINEAR FOOT
- 2X10 BARGE W/ 1X6 SHADOW BOARD
- 2X10 FASCIA W/ SEAMLESS 5" K-STYLE ALUM. GUTTER
- CEMENT BOARD LAP SIDING, 6" REVEAL (7 1/4"), SMOOTH
- 5/4 X 6 WINDOW, DOOR & CORNER TRIM
- 24" EAVES TYP. U.N.O.
- 24" POST CAP PER STRUCTURAL, PAINT BLACK
- EXPOSED 6X6 DF-L #1 POST

**R327.3 Roofing**

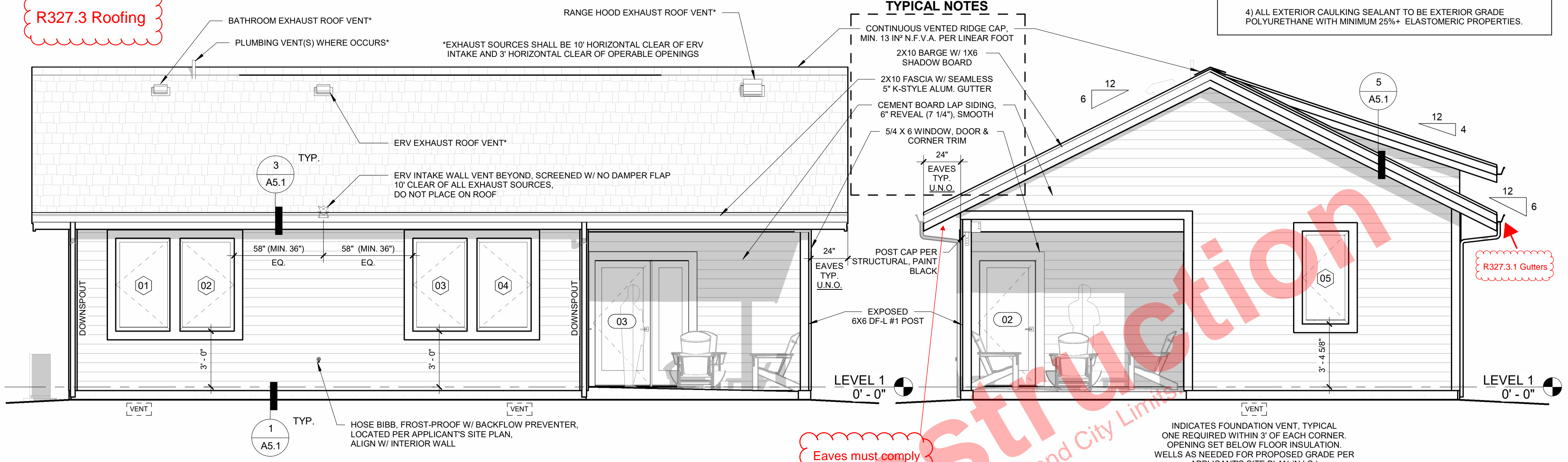

1 FRONT ELEVATION  
1/4" = 1'-0"

2 RIGHT ELEVATION  
1/4" = 1'-0"

Eaves must comply R327.3.4.1

INDICATES FOUNDATION VENT, TYPICAL ONE REQUIRED WITHIN 3' OF EACH CORNER. OPENING SET BELOW FLOOR INSULATION. WELLS AS NEEDED FOR PROPOSED GRADE PER APPLICANT'S SITE PLAN (N.I.C.)

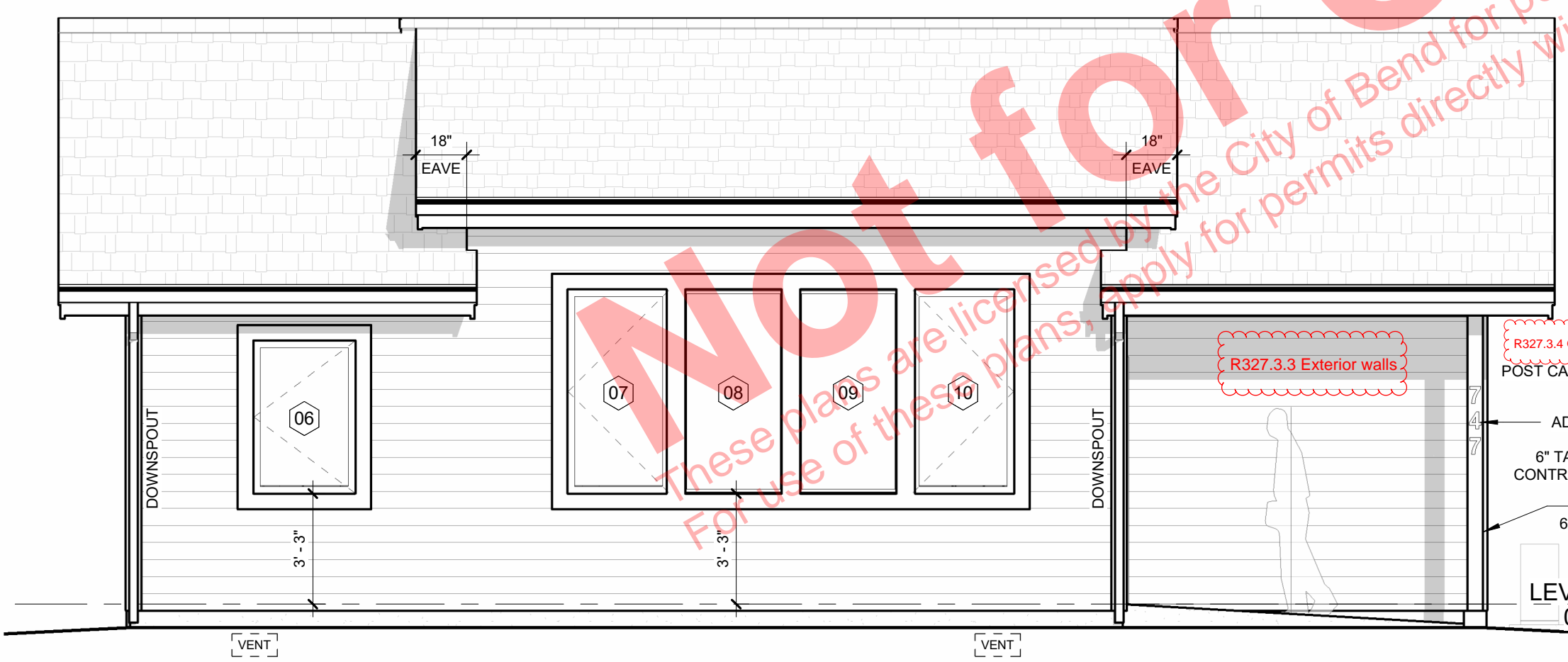

3 BACK ELEVATION  
1/4" = 1'-0"

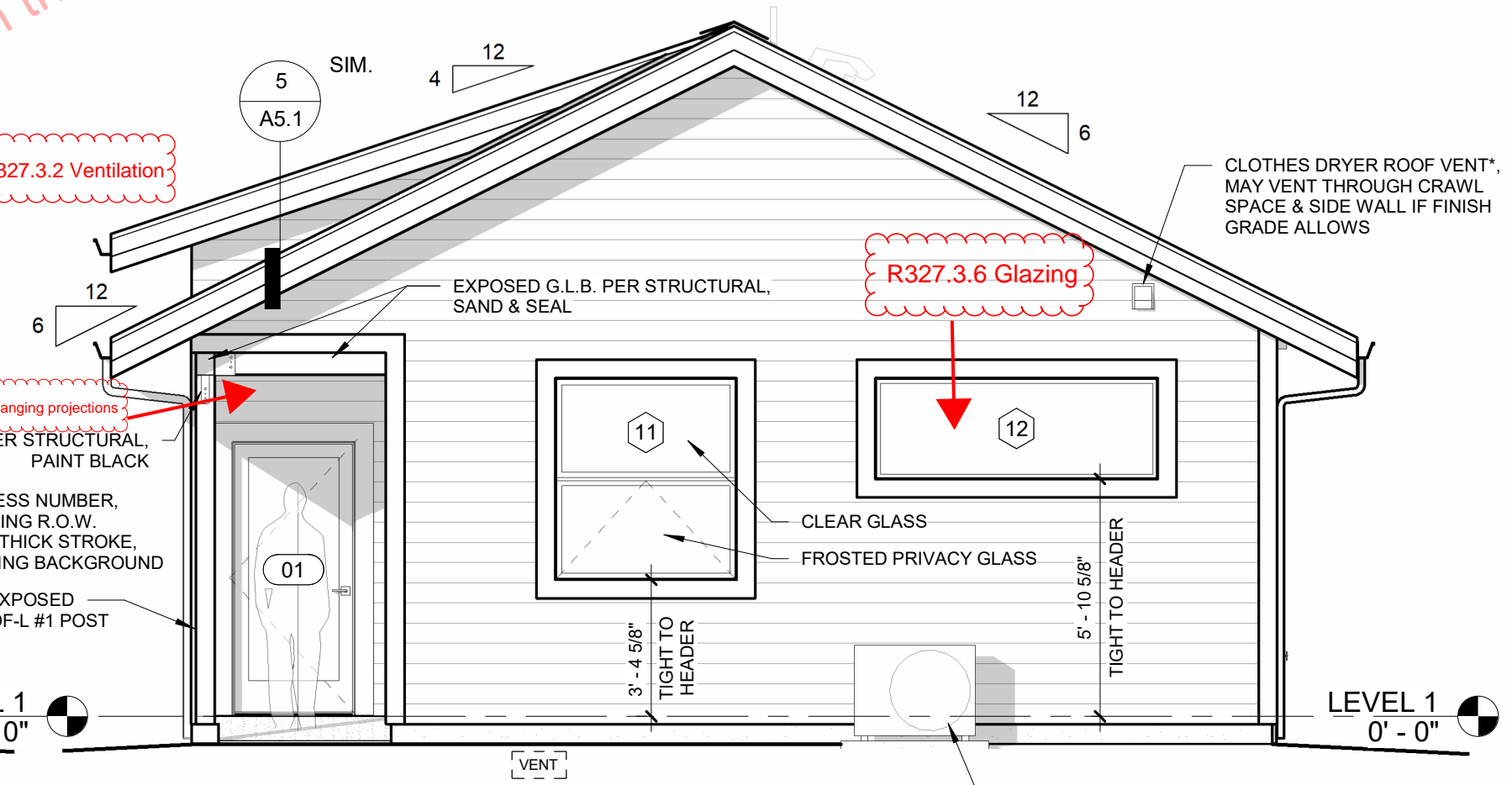

4 LEFT ELEVATION  
1/4" = 1'-0"

JURISDICTION APPROVAL

REGISTERED ARCHITECT  
IAN BURGESS  
BEND, OREGON  
LIC # 6925  
STATE OF OREGON  
EXPIRES 12/31/2027



**SIERRA JAMES**



EXTERIOR ELEVATIONS

MASTER REISSUE PERMIT  
03/11/2026

(541) 306-3775  
INFO@SIERRA-JAMES.COM

**DESCHUTES BUNGALOW**

PROJECT ADDRESS

**A2.1**

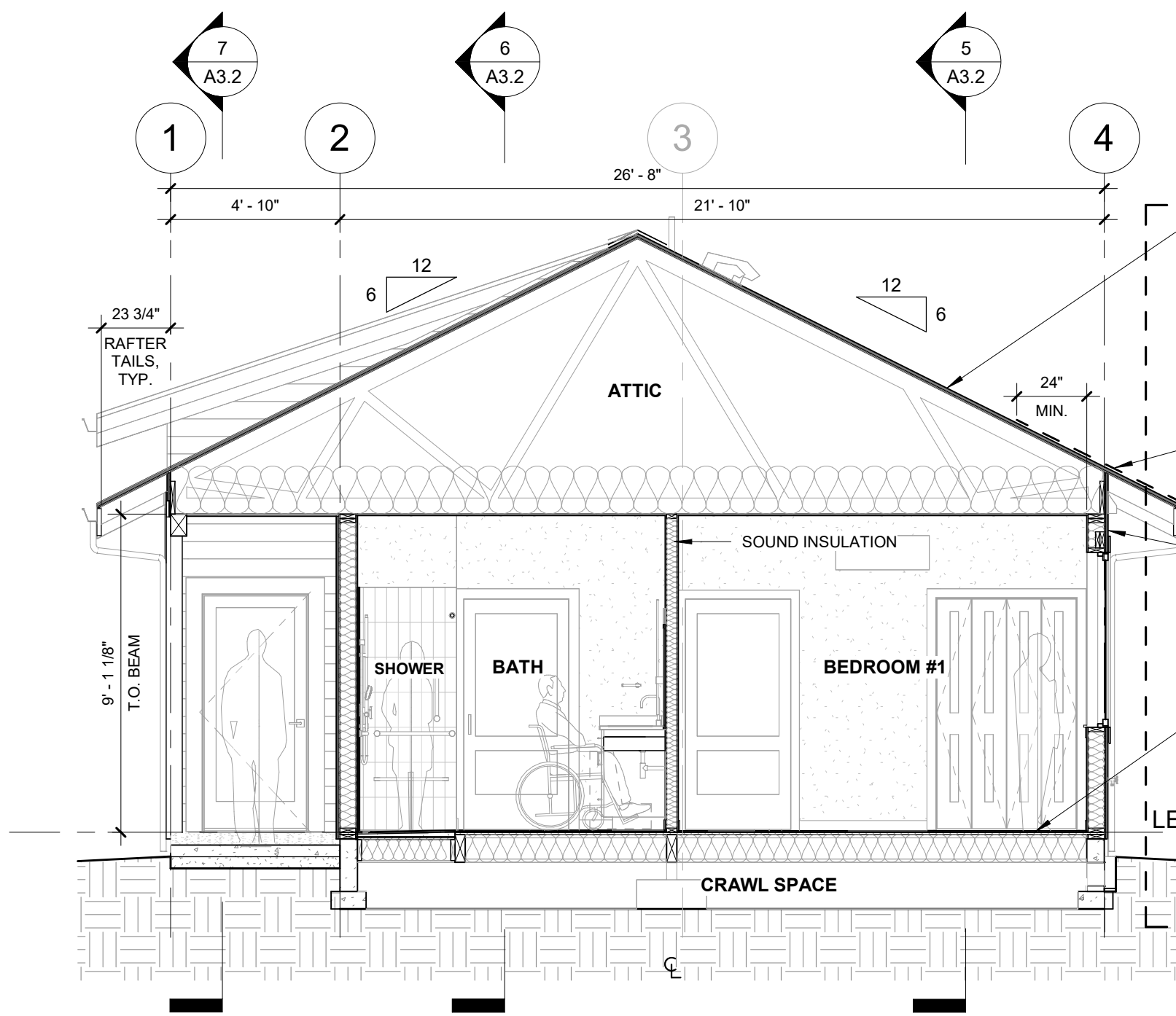

1 SECTION 1  
1/4" = 1'-0"

**TYPICAL BUILDING ASSEMBLIES**

**TYPICAL VENTED ROOF ASSEMBLY:**  
 COMPOSITE SHINGLE ROOFING PER ROOF PLAN  
 ROOFING MFR. APPROVED UNDERLAYMENT  
 ROOF SHEATHING PER STRUCTURAL TRUSSES @ 24" O.C. PER MFR.  
 MIN. 1" VENT BAFFLES AS NEEDED  
 MIN. R-49 BLOW-IN OR BATT FIBERGLASS INSULATION CLASS I OR II VAPOR RETARDER AT CEILING  
 MIN. 1/2" GYPSUM BOARD CEILING (PRIMARY AIR BARRIER, SEAL ALL PENETRATIONS)

SELF-ADHERING POLYMER-MODIFIED BITUMEN ICE BARRIERS REQ'D FROM ALL ROOF EDGES TO MIN. 24" INSIDE THE EXTERIOR WALL LINE OF THE BUILDING

**TYPICAL EXTERIOR WALL ASSEMBLY:**  
 SIDING PER EXTERIOR ELEVATIONS  
 DRAINABLE W.R.B., TAPE ALL SEAMS  
 SHEATHING PER STRUCTURAL 2X6 STUDS @ 24" O.C.  
 MIN. R-21 BLOW-IN FIBERGLASS INSULATION 1/2" GYPSUM BOARD (PRIMARY AIR BARRIER, SEAL ALL PENETRATIONS)

**TYPICAL FLOOR ASSEMBLY:**  
 FINISH FLOORING PER FLOOR PLAN  
 3/4" T&G FLOOR SHEATHING PER STRUCTURAL 9.5" I-JOIST @ 16" O.C. PER STRUCTURAL  
 MIN. R-30 UNDERFLOOR INSULATION

LEVEL 1 0'-0"  
 CRAWL SPACE VENTS PER FOUNDATION PLAN, VENT WELLS AS NEEDED PER FINISH GRADE  
 LEVEL 1 IS TOP OF SUBFLOOR, TYPICAL

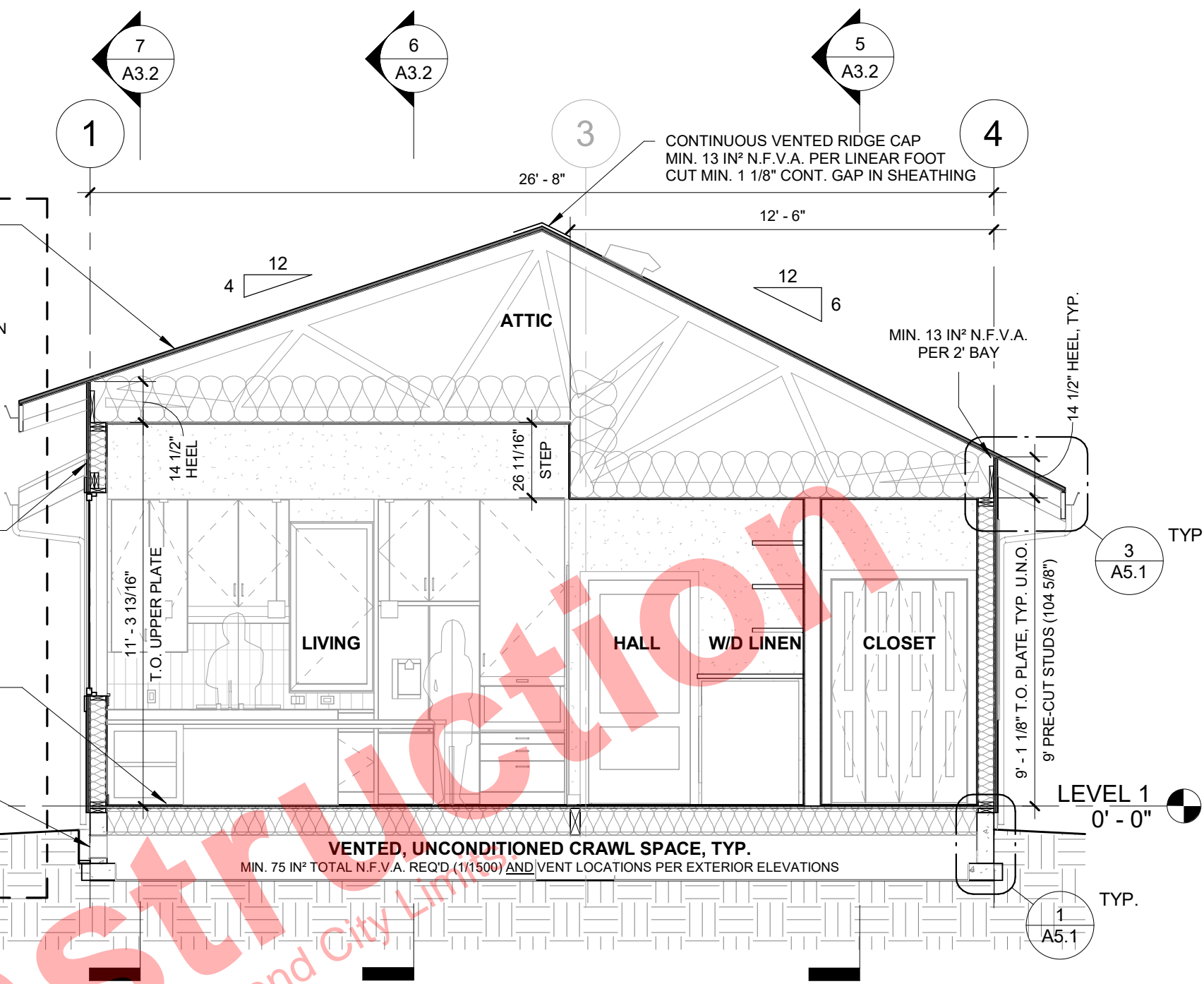

2 SECTION 2 (TYPICAL NOTES)  
1/4" = 1'-0"

**ROOF VENTING CALCULATIONS**  
 $26.75' / 150 = 25.7 \text{ IN}^2$   
 $25.7 \text{ IN}^2 / 2 = 13 \text{ IN}^2 \text{ PER LINEAR FOOT (RIDGE VENT)}$   
 $12.9 \text{ IN}^2 / 2 = 6.5 \text{ IN}^2 \text{ PER LINEAR FOOT (EA VE VENTS)}$

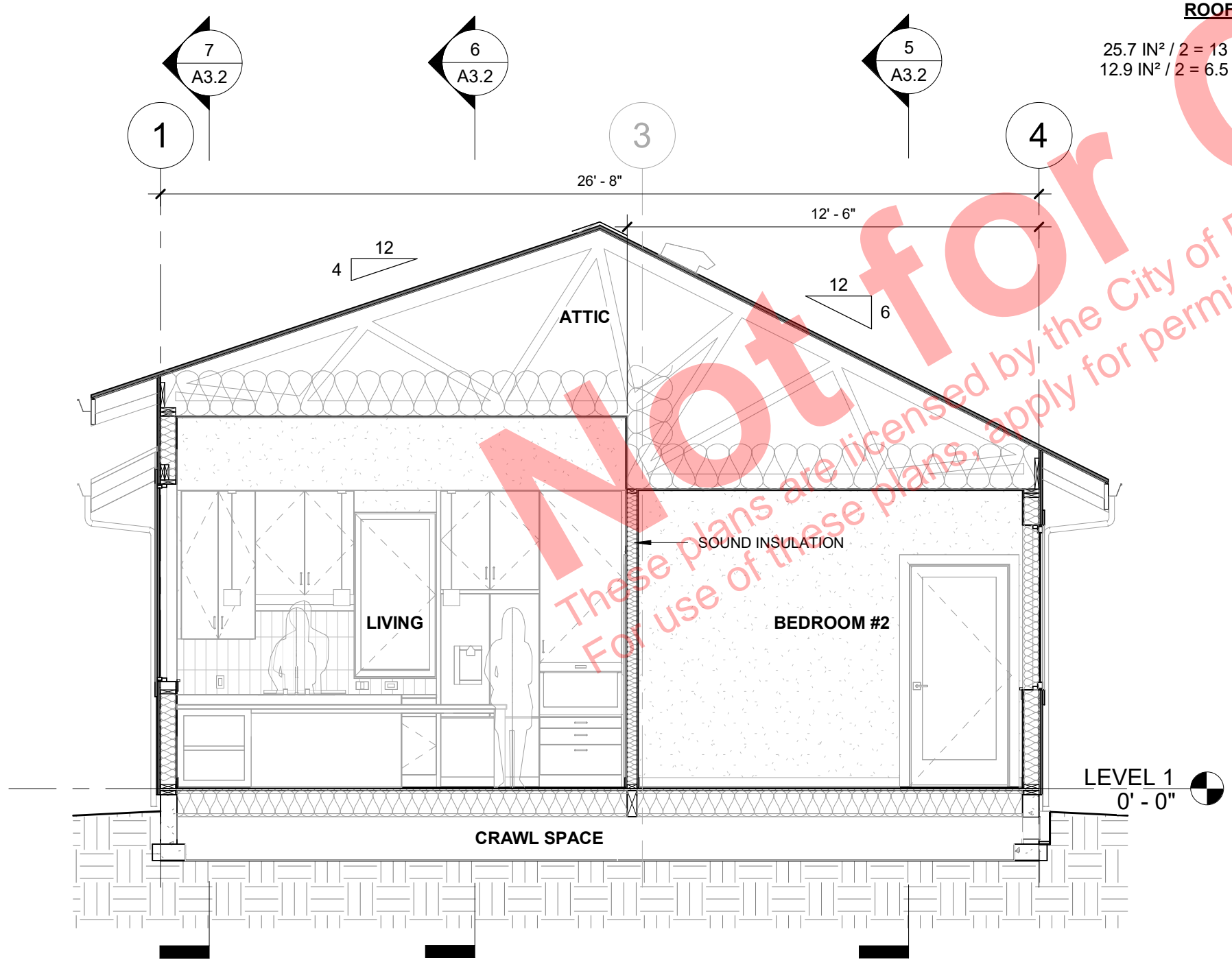

3 SECTION 3  
1/4" = 1'-0"

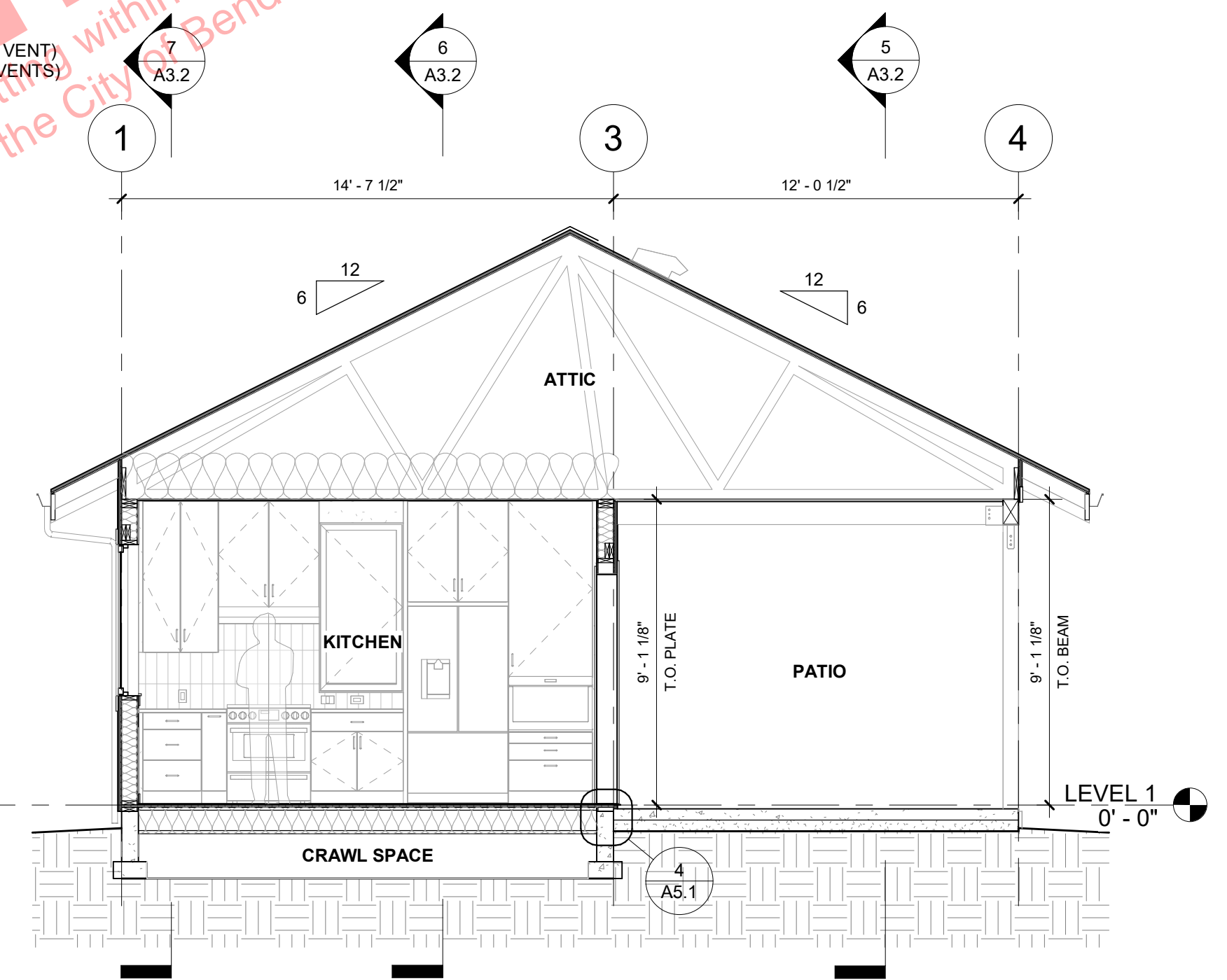

4 SECTION 4  
1/4" = 1'-0"

JURISDICTION APPROVAL

REGISTERED ARCHITECT  
 IAN BURGESS  
*Ian Burgess*  
 BEND, OREGON  
 LIC # 6925  
 STATE OF OREGON  
 EXPIRES 12/31/2027



BUILDING SECTIONS

MASTER REISSUE PERMIT  
 03/11/2026

(541) 306-3775  
 INFO@SIERRA-JAMES.COM  
**DESCHUTES BUNGALOW**  
 PROJECT ADDRESS

**A3.1**

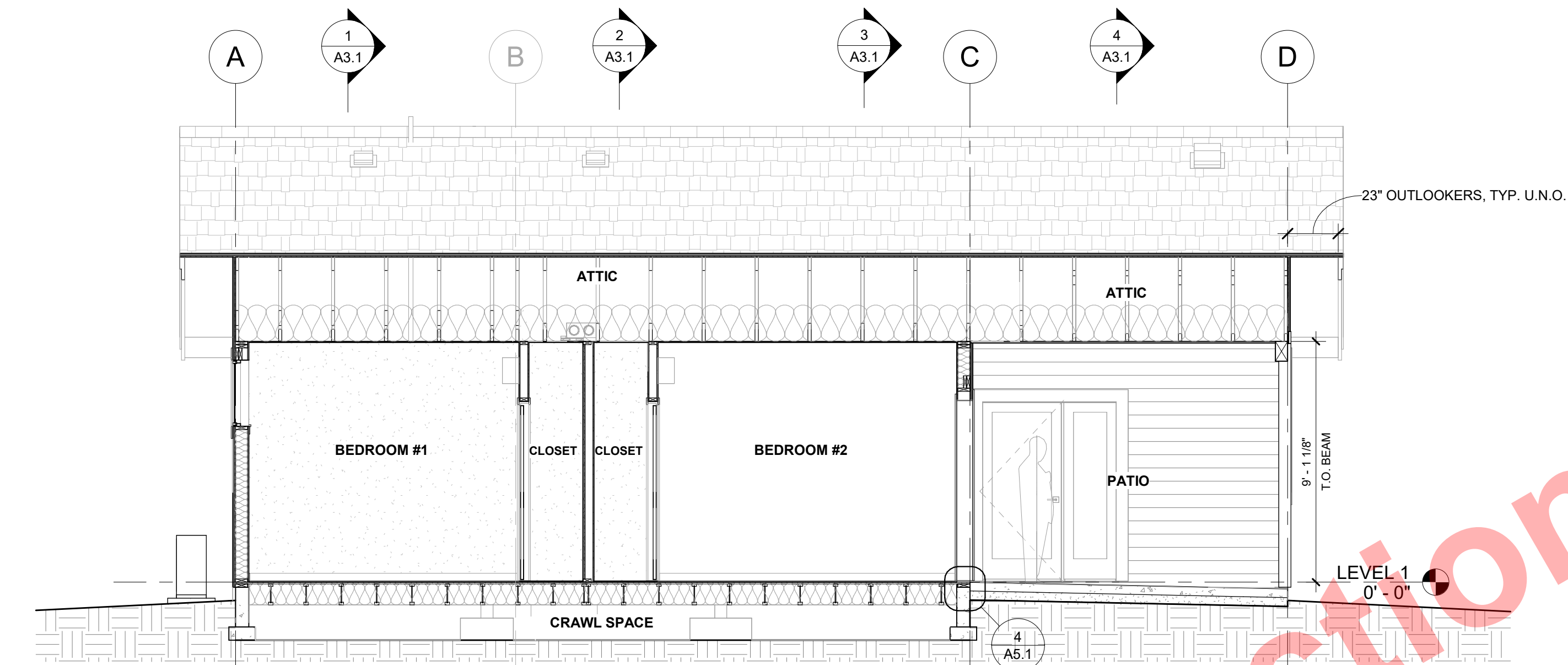

5 SECTION 5  
1/4" = 1'-0"

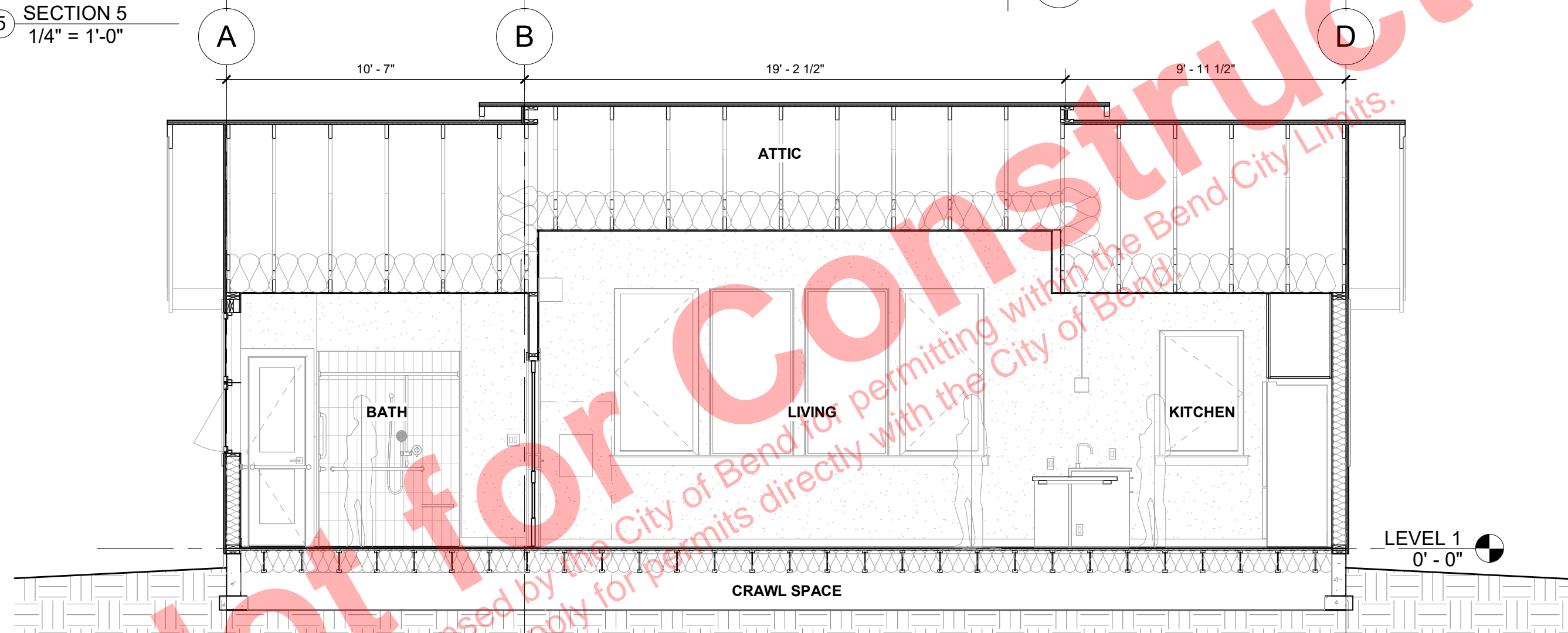

6 SECTION 6  
1/4" = 1'-0"

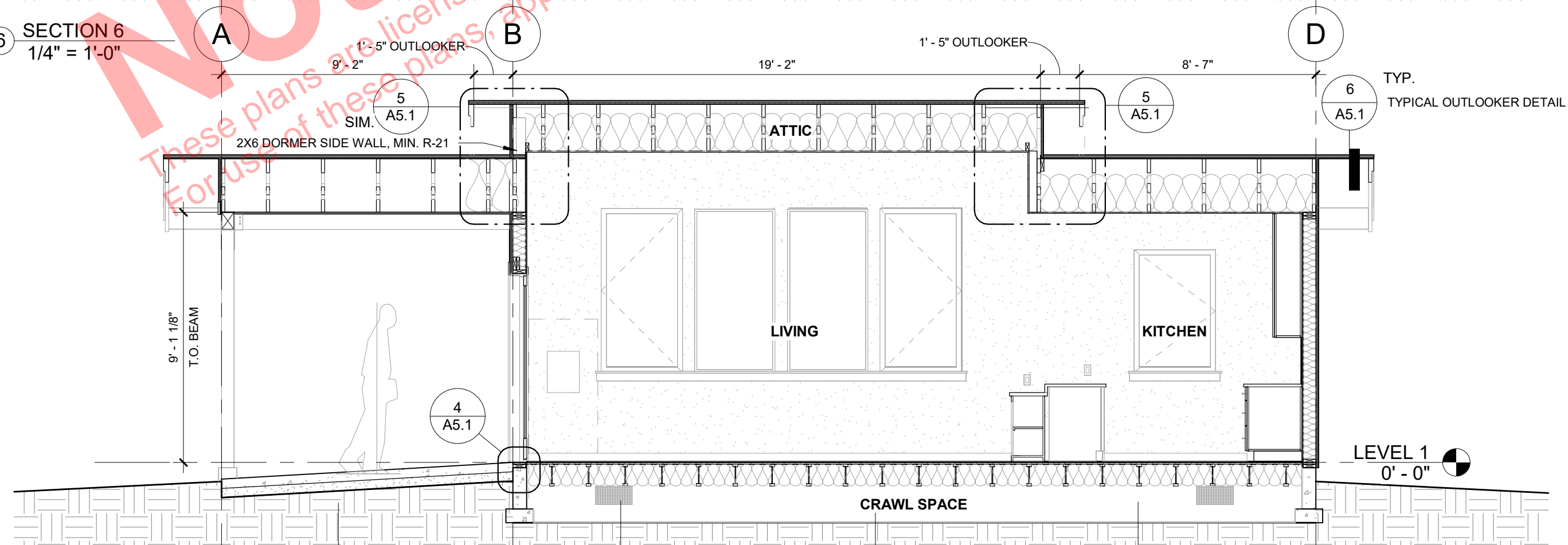

7 SECTION 7  
1/4" = 1'-0"

JURISDICTION APPROVAL

REGISTERED ARCHITECT  
IAN BURGESS  
*Ian Burgess*  
BEND, OREGON  
LIC # 6925  
STATE OF OREGON  
EXPIRES 12/31/2027

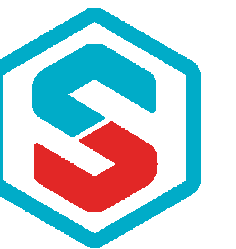

SIERRA  
JAMES



BUILDING SECTIONS

MASTER REISSUE PERMIT  
03/11/2026

(541) 306-3775  
INFO@SIERRA-JAMES.COM  
**DESCHUTES BUNGALOW**  
PROJECT ADDRESS

**A3.2**

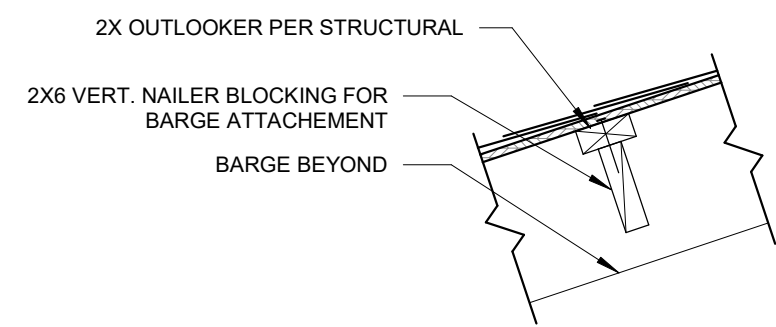

6 OUTLOOKER CROSS SECTION DETAIL  
1" = 1'-0"

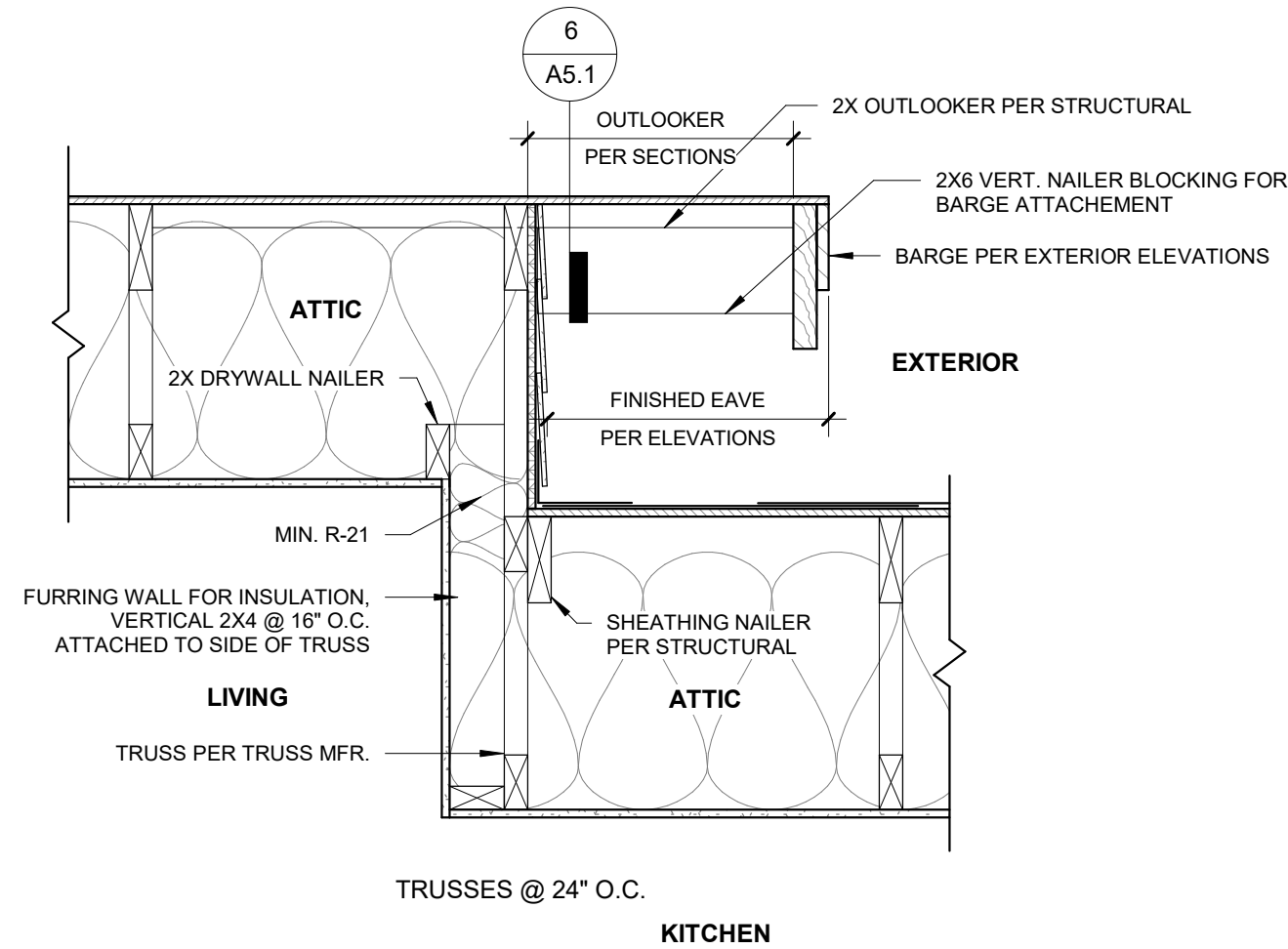

5 ROOF TRANSITION  
1" = 1'-0"

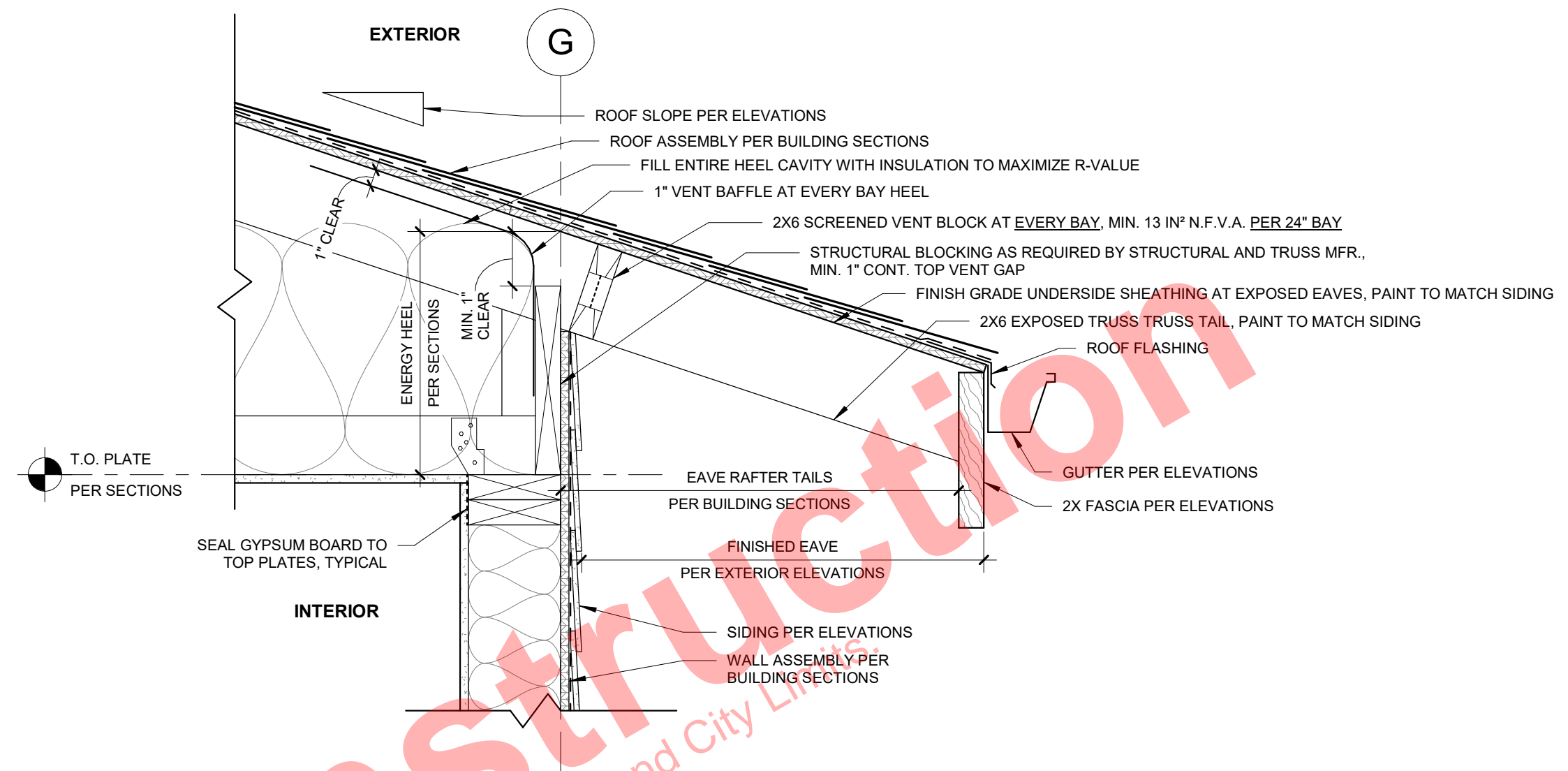

3 TYPICAL EAVE SECTION  
1 1/2" = 1'-0"

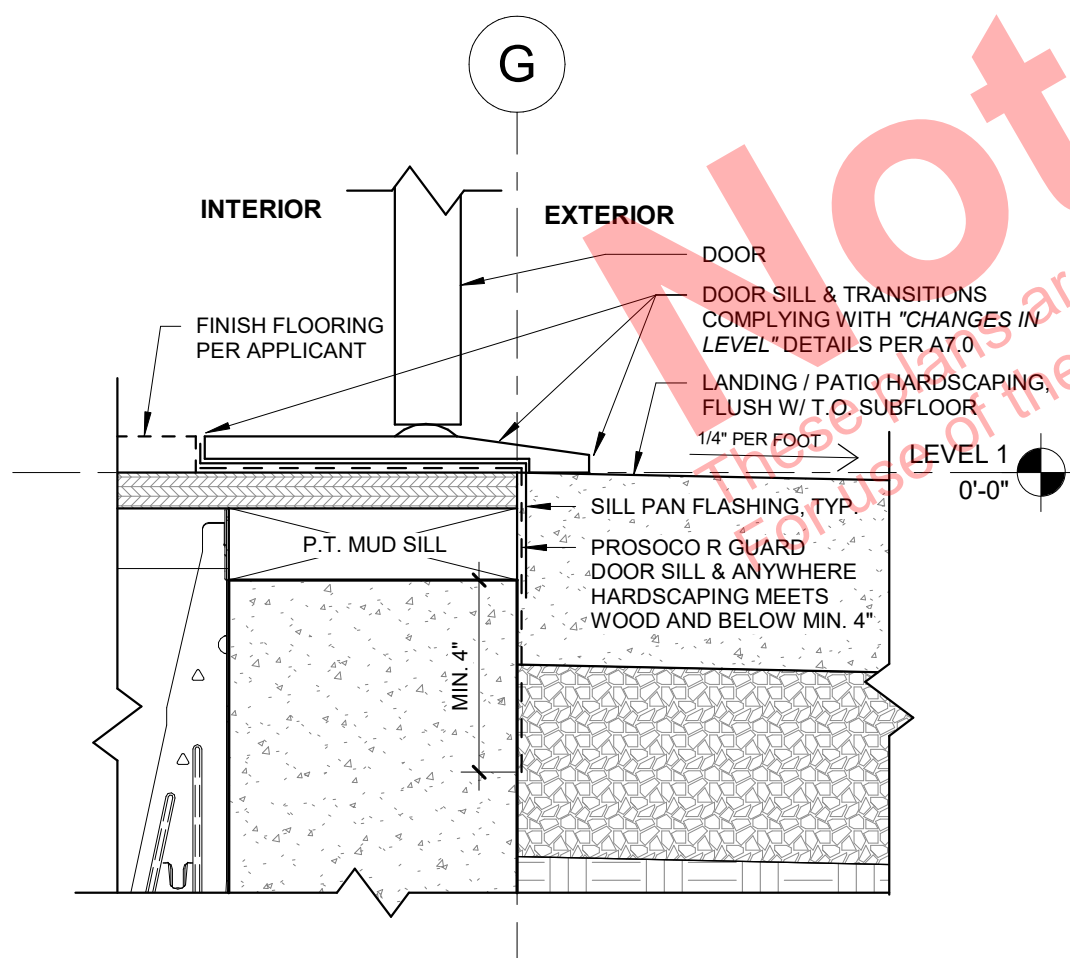

4 EXTERIOR DOOR ACCESSIBLE SILL DETAIL  
3" = 1'-0"

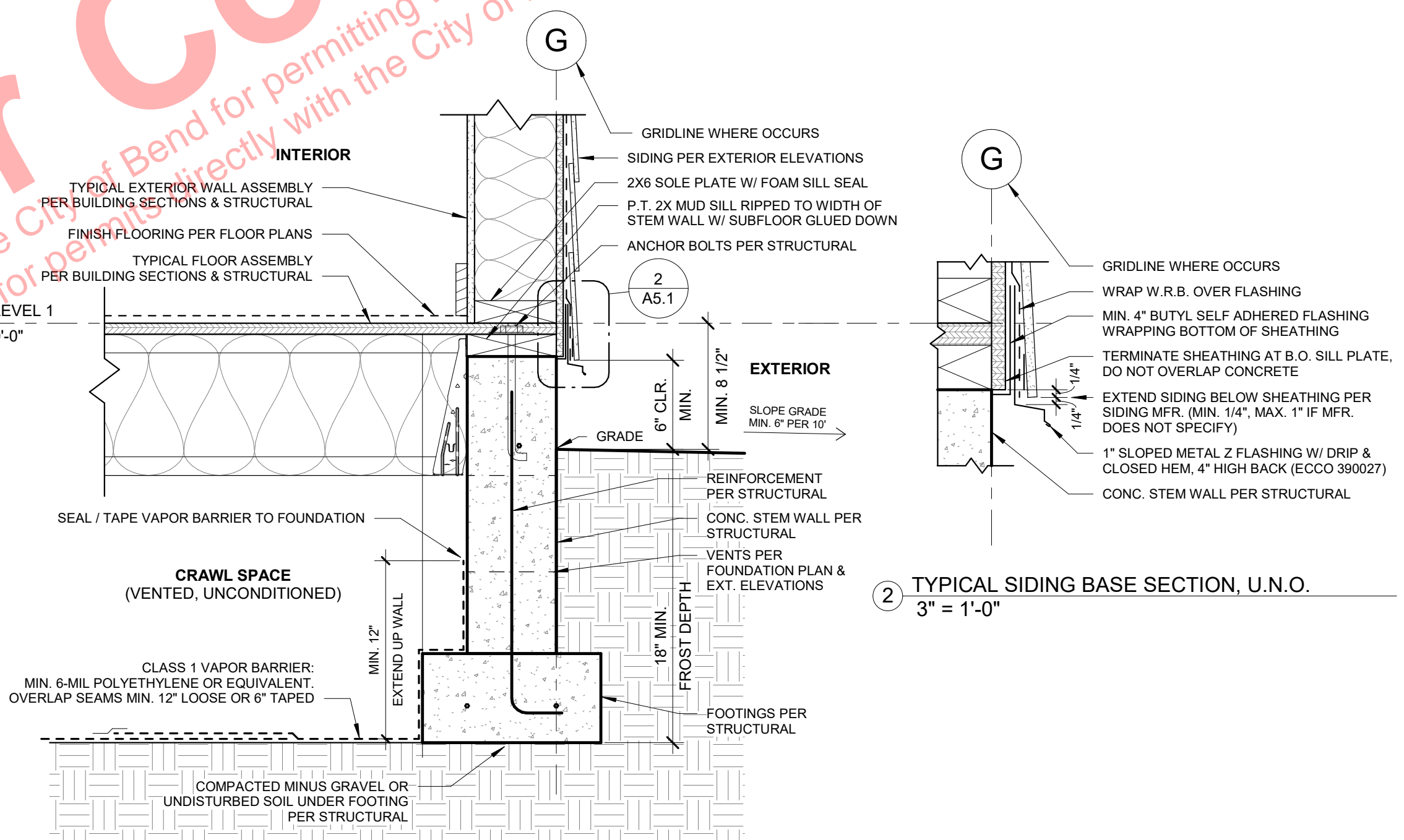

1 TYPICAL STEM WALL SECTION  
1 1/2" = 1'-0"

2 TYPICAL SIDING BASE SECTION, U.N.O.  
3" = 1'-0"

JURISDICTION APPROVAL

REGISTERED ARCHITECT  
IAN BURGESS  
BEND, OREGON  
LIC # 6925  
STATE OF OREGON  
EXPIRES 12/31/2027

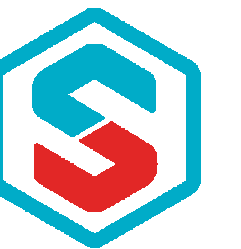

SIERRA JAMES



EXTERIOR DETAILS

MASTER REISSUE PERMIT  
03/11/2026

(541) 306-3775  
INFO@SIERRA-JAMES.COM

DESCHUTES BUNGALOW  
PROJECT ADDRESS

A5.1

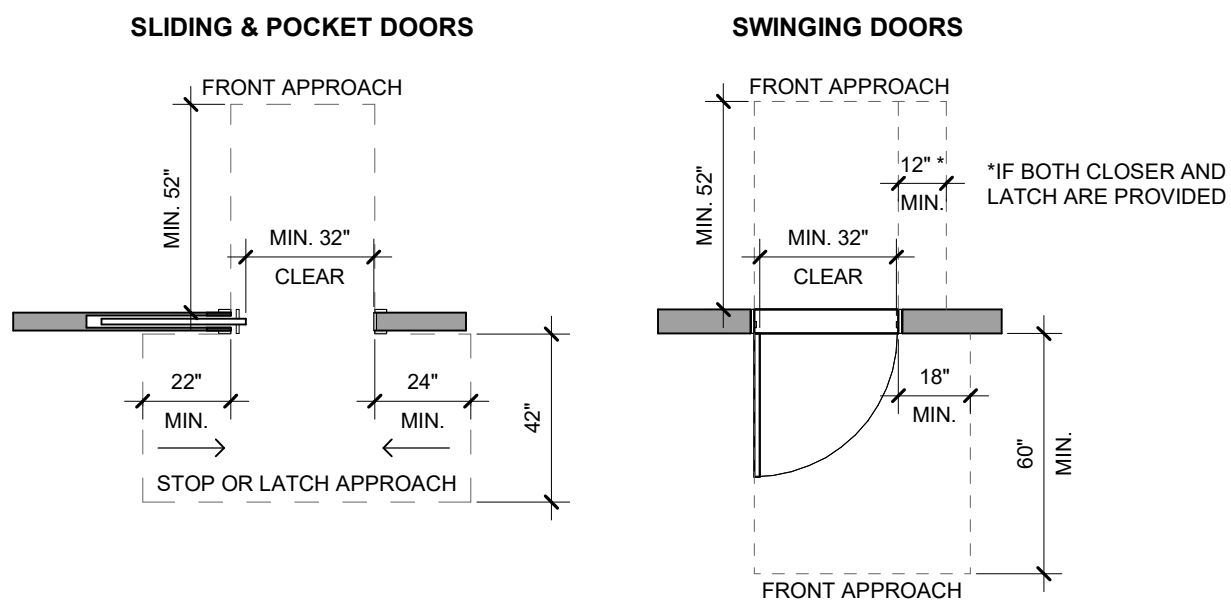

**FLOORING GENERAL NOTES**

- 1) FLOOR SURFACES SHALL BE STABLE, FIRM, AND SLIP RESISTANT. FLOORING IN WET AREAS (BATHROOMS, KITCHENS, ENTRYWAYS, ETC.) SHALL HAVE A DYNAMIC COEFFICIENT OF FRICTION (DCOF) OF 0.42 OR HIGHER PER ANSI A137.1.
- 2) FLOOR TRANSITIONS SHALL COMPLY WITH "CHANGES IN LEVEL" DETAILS PER A7.0.
- 3) CARPET OR CARPET TILE SHALL BE SECURELY ATTACHED AND SHALL HAVE A FIRM CUSHION, PAD, OR BACKING OR NO CUSHION OR PAD. CARPET OR CARPET TILE SHALL HAVE A LEVEL LOOP, TEXTURED LOOP, LEVEL CUT PILE, OR LEVEL CUT/UNCUT PILE TEXTURE. THE PILE SHALL BE 1/2 INCH (13 MM) MAXIMUM IN HEIGHT. EXPOSED EDGES OF CARPET SHALL BE FASTENED TO THE FLOOR AND SHALL HAVE TRIM ALONG THE ENTIRE LENGTH OF THE EXPOSED EDGE. CARPET EDGE TRIM SHALL COMPLY WITH "CHANGE IN LEVEL" PER A7.0.
- 4) OPENINGS IN FLOOR SURFACES SHALL BE OF A SIZE THAT DOES NOT PERMIT THE PASSAGE OF A 1/2-INCH DIAMETER SPHERE. ELONGATED OPENINGS SHALL BE PLACED SO THAT THE LONG DIMENSION IS PERPENDICULAR TO THE PREDOMINANT DIRECTION OF TRAVEL.
- 5) RECOMMEND CHANGE IN COLOR CONTRAST AT FLOORING TRANSITIONS FOR VISUAL IMPAIRMENT.

**ACCESSIBLE GENERAL NOTES**

- 1) DIMENSIONS ON THIS SHEET ARE IN INCHES AND MILLIMETER, U.N.O.
- 2) REINFORCEMENT SHALL BE PROVIDED FOR THE INSTALLATION OF ALL GRAB BARS SHOWN WHETHER GRAB BARS WILL BE INSTALLED OR NOT DURING CONSTRUCTION. GRAB BARS ARE NOT REQ'D FOR TYPE A. REINFORCEMENT FOR FUTURE INSTALLATION OF GRAB BARS IS REQUIRED FOR TYPE A.
- 3) OPERABLE PARTS SHALL BE OPERABLE WITH ONE HAND AND SHALL NOT REQUIRE TIGHT GRASPING, PINCHING, OR TWISTING OF THE WRIST. THE FORCE REQUIRED TO ACTIVATE OPERABLE PARTS SHALL BE 5.0 POUNDS (22.2 N) MAXIMUM.
- 4) OPERABLE PARTS SHALL BE LOCATED WITHIN ONE OF THE "REACH RANGES" DETAILED BELOW. THIS INCLUDES BUT IS NOT LIMITED TO LIGHTING CONTROLS, ELECTRICAL PANELBOARDS, ELECTRICAL SWITCHES AND RECEPTACLE OUTLETS, ENVIRONMENTAL CONTROLS, APPLIANCE CONTROLS, PLUMBING FIXTURE CONTROLS, AND USER CONTROLS FOR SECURITY OR INTERCOM SYSTEMS, DOOR HANDLES & LOCKS, OPERABLE WINDOWS REQUIRED FOR NATURAL VENTILATION OR EMERGENCY EGRESS, ETC.  
EXCEPTIONS: A) APPLIANCE DOORS AND DOOR LATCHING DEVICES  
B) BOTTOM-HINGES APPLIANCE DOORS, WHEN IN THE OPEN POSITION

**DOOR CLEARANCES**

1/4" = 1'-0"

**TURNING SPACE & DOOR CLEARANCE NOTES**

- 1) ALL ROOMS SERVED BY AN ACCESSIBLE ROUTE SHALL PROVIDE A TURNING SPACE AND DOOR MANEUVERING CLEARANCES. EXCEPTIONS: TURNING SPACE AND MANEUVERING CLEARANCE IS NOT REQUIRED WITHIN CLOSETS OR PANTRIES THAT ARE 48 INCHES MAXIMUM IN DEPTH.
- 2) CHANGES IN LEVEL SHALL NOT BE PERMITTED WITHIN THE TURNING SPACE. SLOPES NOT STEEPER THAN 1:48 (1/4" PER FOOT OR 2%) SHALL BE PERMITTED.
- 3) DOORS SHALL BE PERMITTED TO SWING INTO TURNING SPACES, U.N.O.

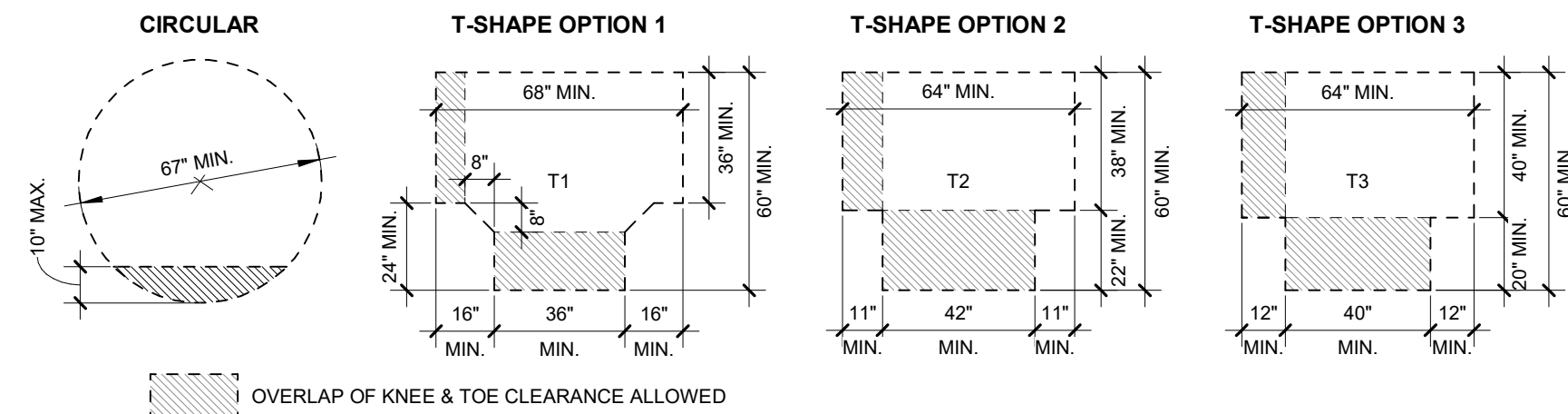

**TURNING SPACE (NEW BUILDINGS)**

1/4" = 1'-0"

**CLEAR SPACE NOTES**

- 1) CLEAR FLOOR SPACE SHALL BE PERMITTED TO INCLUDE KNEE AND TOE CLEARANCE, U.N.O.
- 2) ONE FULL, UNOBSTRUCTED SIDE OF A CLEAR FLOOR SPACE SHALL ADJOIN OR OVERLAP AN ACCESSIBLE ROUTE OR ADJOIN ANOTHER CLEAR FLOOR SPACE.

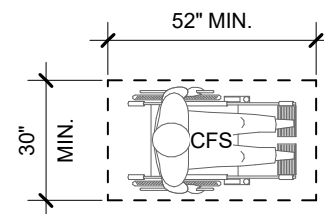

**CLEAR FLOOR SPACE (NEW BUILDINGS)**

N.T.S.

**BEVELED CHANGES IN LEVEL**

BEVELED CHANGES IN LEVEL GREATER THAN 1/4 INCH IN HEIGHT AND NOT MORE THAN 1/2 INCH MAXIMUM IN HEIGHT SHALL BE BEVELED WITH A SLOPE NOT STEEPER THAN 1:2.

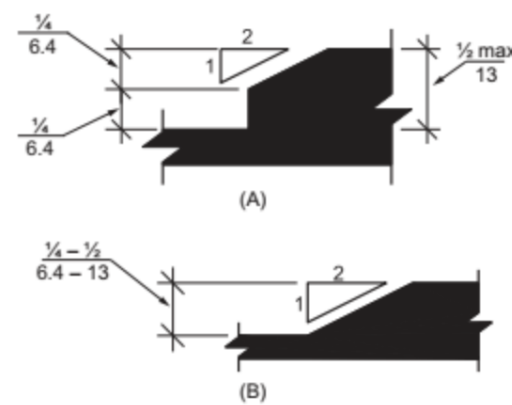

**VERTICAL CHANGES IN LEVEL**

CHANGES IN LEVEL OF 1/4 INCH MAXIMUM IN HEIGHT SHALL BE PERMITTED TO BE VERTICAL.



**CHANGES IN LEVEL**

N.T.S.

**CABINET & POCKET DOOR PULLS**

N.T.S.

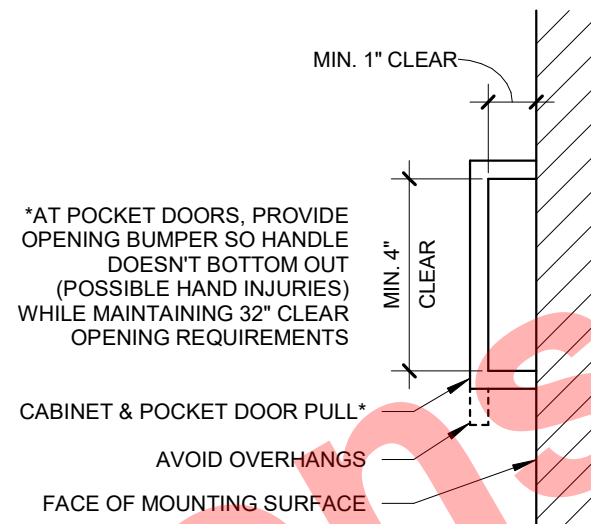

**PROTRUDING OBJECT NOTES**

- 1) OBJECTS WITH LEADING EDGES MORE THAN 27 INCHES AND NOT MORE THAN 80 INCHES ABOVE THE FLOOR SHALL PROTRUDE 4 INCHES MAXIMUM HORIZONTALLY INTO A CIRCULATION PATH. EXCEPTION: HANDRAILS SHALL BE PERMITTED TO PROTRUDE 4 1/2 INCHES (115 MM) MAXIMUM.

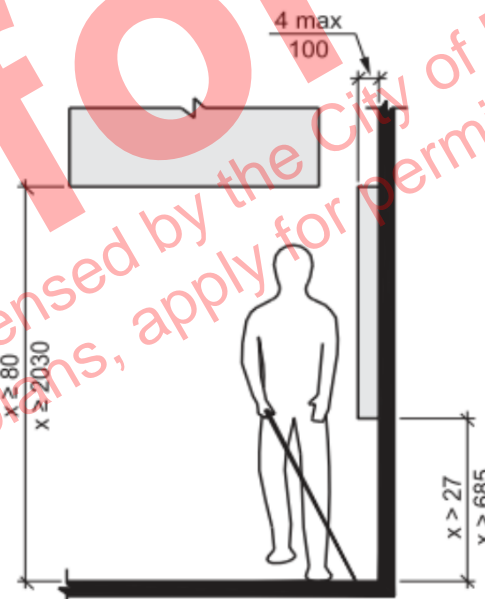

**PROTRUDING OBJECTS**

N.T.S.

**KNEE & TOE SPACE NOTES**

- 1) CLEAR FLOOR SPACE SHALL BE PERMITTED TO INCLUDE KNEE AND TOE CLEARANCE, U.N.O.
- 2) ONE FULL, UNOBSTRUCTED SIDE OF A CLEAR FLOOR SPACE SHALL ADJOIN OR OVERLAP AN ACCESSIBLE ROUTE OR ADJOIN ANOTHER CLEAR FLOOR SPACE.

**TOE CLEARANCE - ELEVATION**

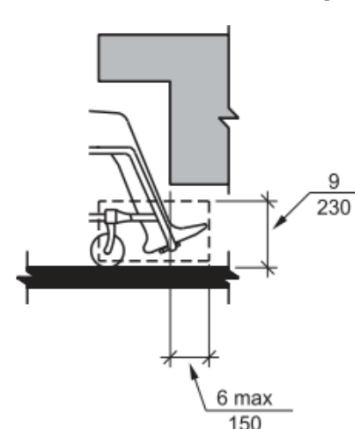

**TOE CLEARANCE - PLAN**

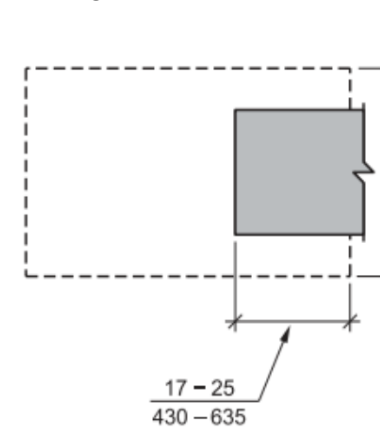

**KNEE CLEARANCE - ELEVATION**

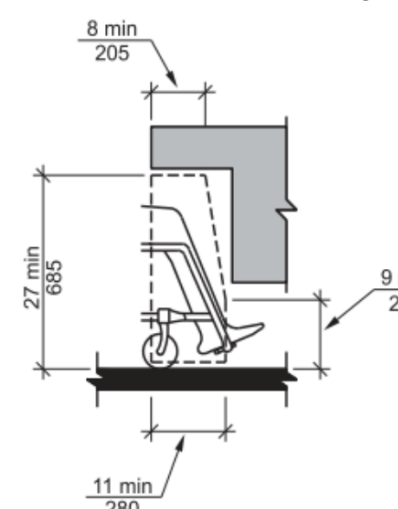

**KNEE CLEARANCE - PLAN**

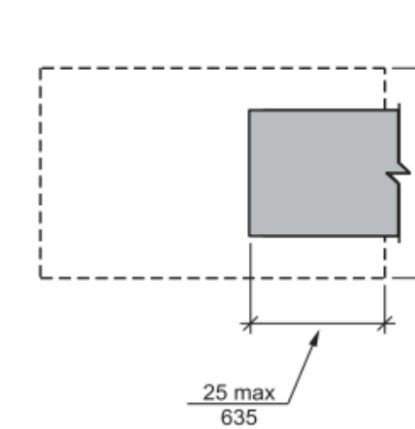

**UNOBSTRUCTED FORWARD REACH**

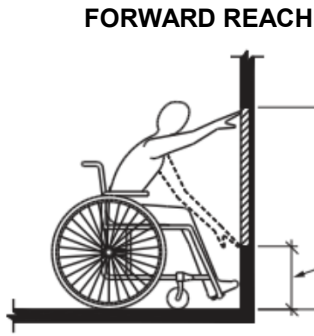

**OBSTRUCTED (MAX. 20") HIGH FORWARD REACH**

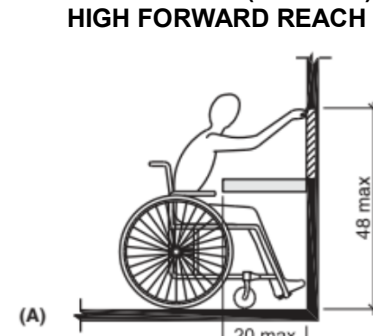

**OBSTRUCTED (20"-25") HIGH FORWARD REACH**

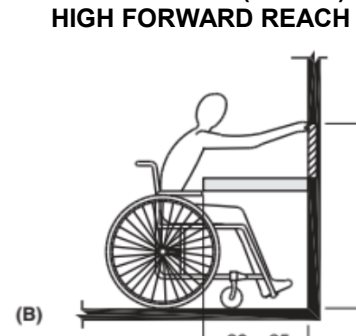

**UNOBSTRUCTED SIDE REACH**

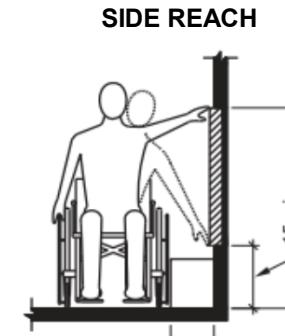

**OBSTRUCTED (MAX. 10") SIDE REACH**

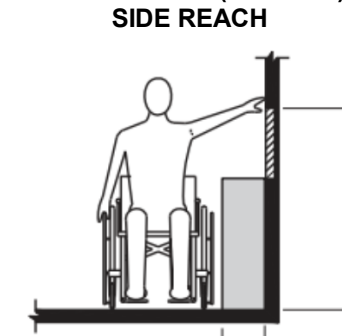

**OBSTRUCTED (10"-24") SIDE REACH**

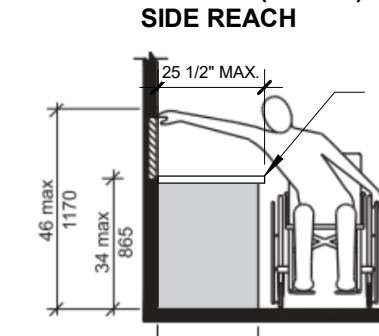

**REACH RANGE**

N.T.S.

**RECTANGULAR SEAT**

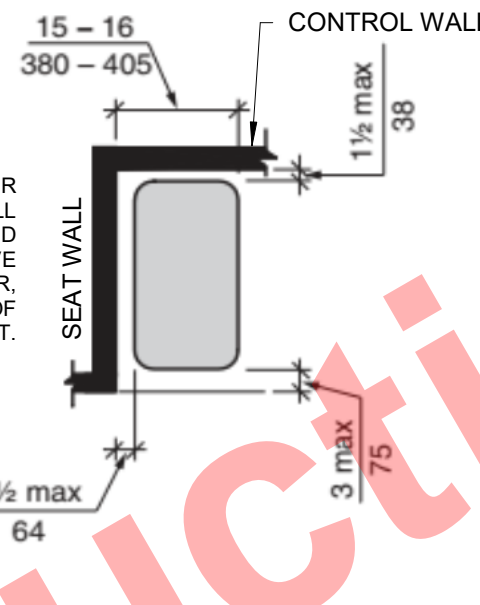

**L-SHAPED SEAT**

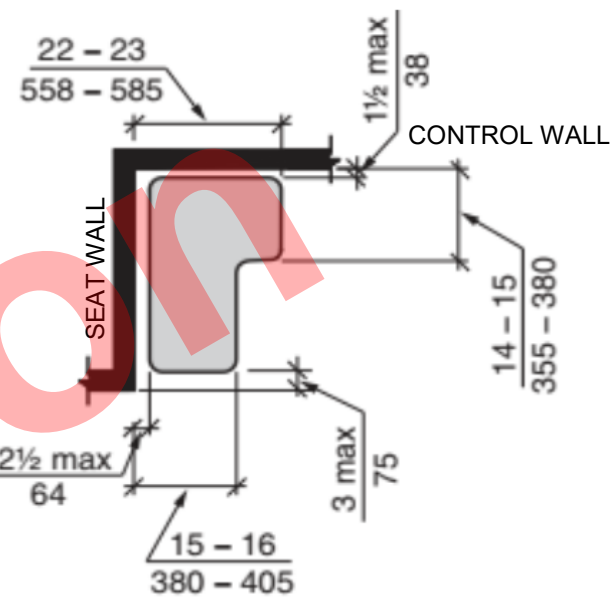

THE HEIGHT OF SHOWER COMPARTMENT SEATS SHALL BE 17 INCHES MINIMUM AND 19 INCHES MAXIMUM ABOVE THE BATHROOM FLOOR, MEASURED TO THE TOP OF THE SEAT.

**SHOWER SEAT**

N.T.S.

**SIZE OF GRAB BARS**

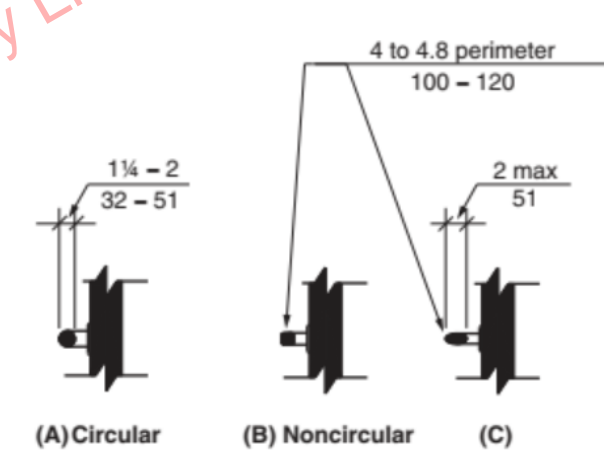

**GRAB BAR CLEARANCES**

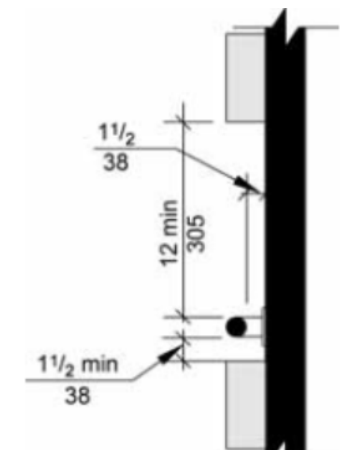

**GRAB BARS**

1/4" = 1'-0"

JURISDICTION APPROVAL



ACCESSIBILITY DETAILS

MASTER REISSUE PERMIT

03/11/2026

(541) 306-3775

INFO@SIERRA-JAMES.COM

DESCHUTES BUNGALOW

PROJECT ADDRESS

A7.0

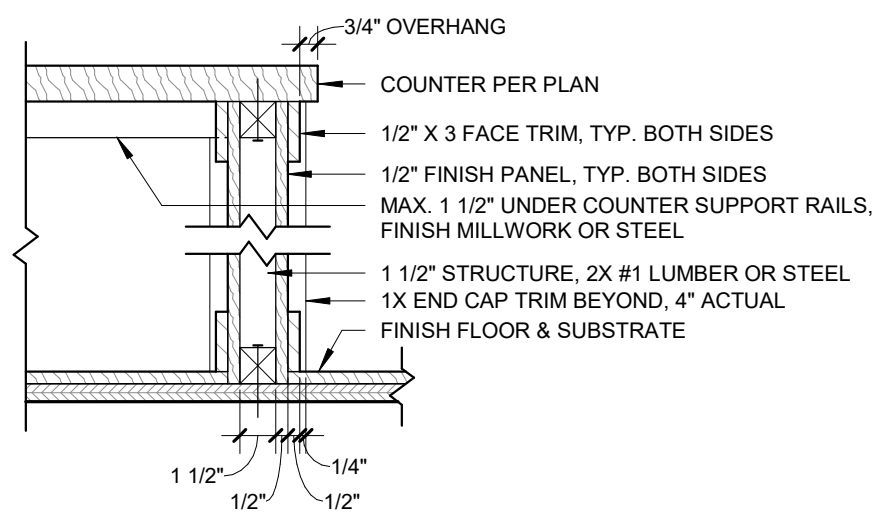

8 PENINSULA END WALL SECTION  
1 1/2" = 1'-0"

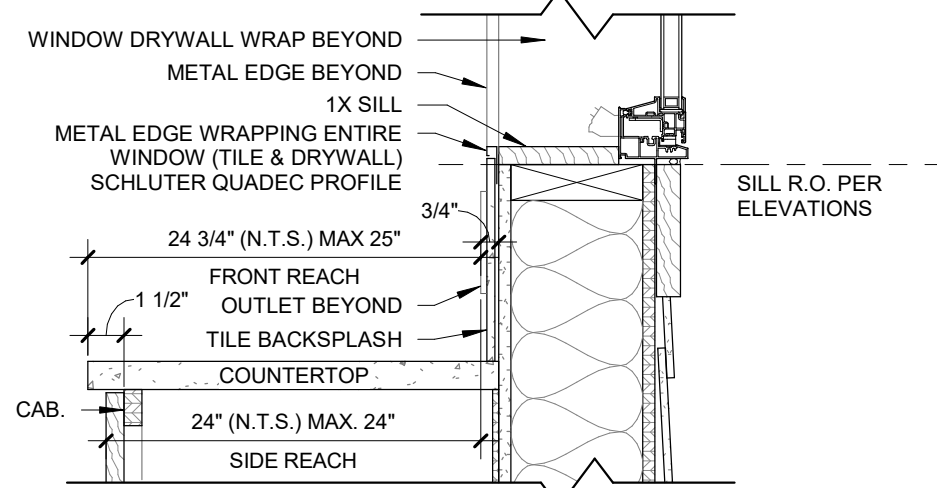

9 KITCHEN COUNTER SECTION  
1 1/2" = 1'-0"

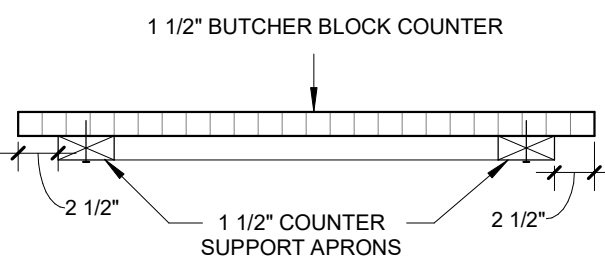

7 OPEN PENINSULA SECTION  
1" = 1'-0"

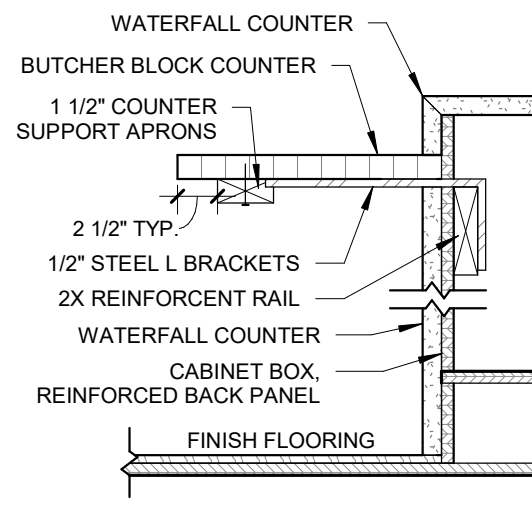

6 PENINSULA SECTION  
1" = 1'-0"

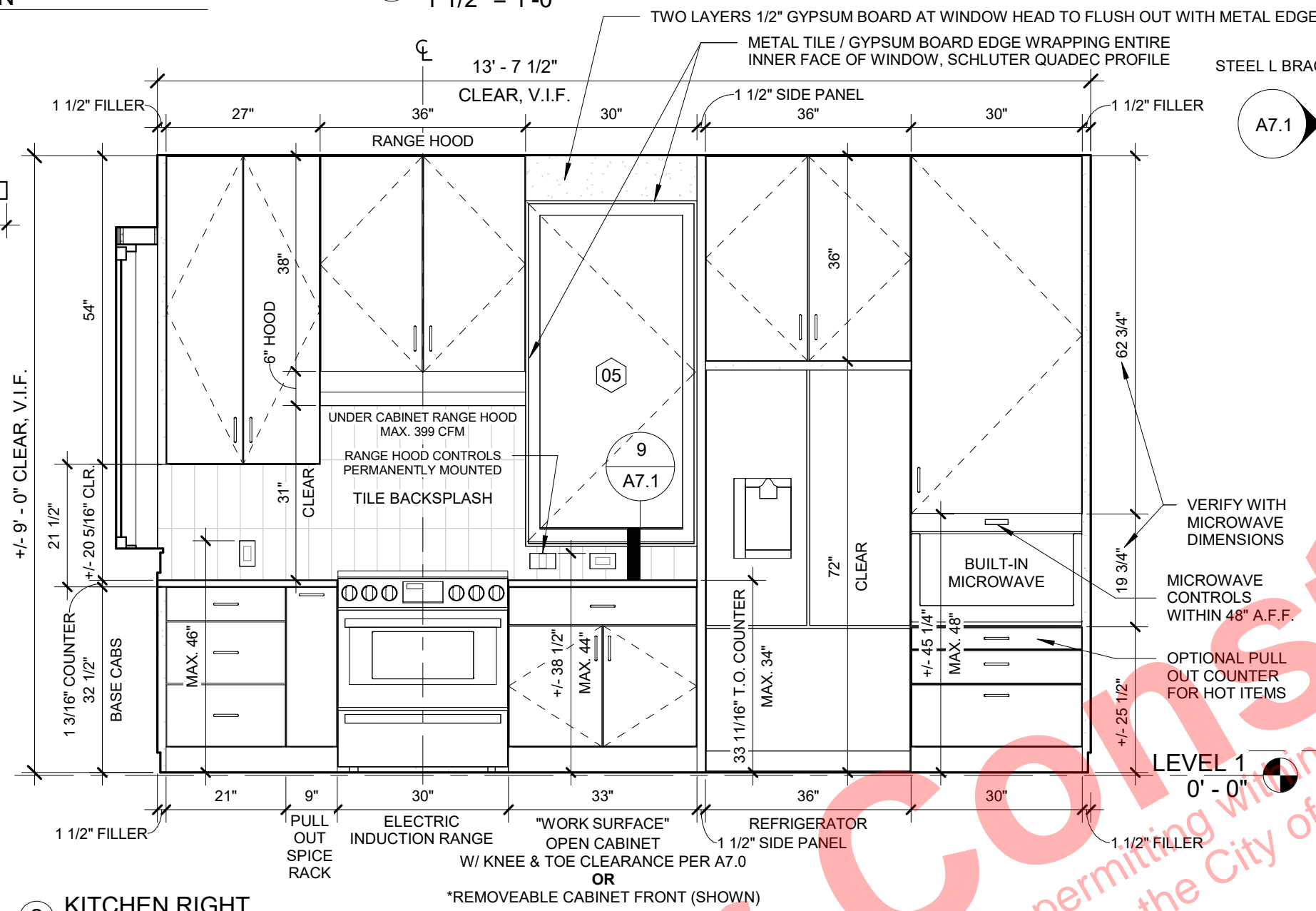

2 KITCHEN RIGHT  
1/2" = 1'-0"

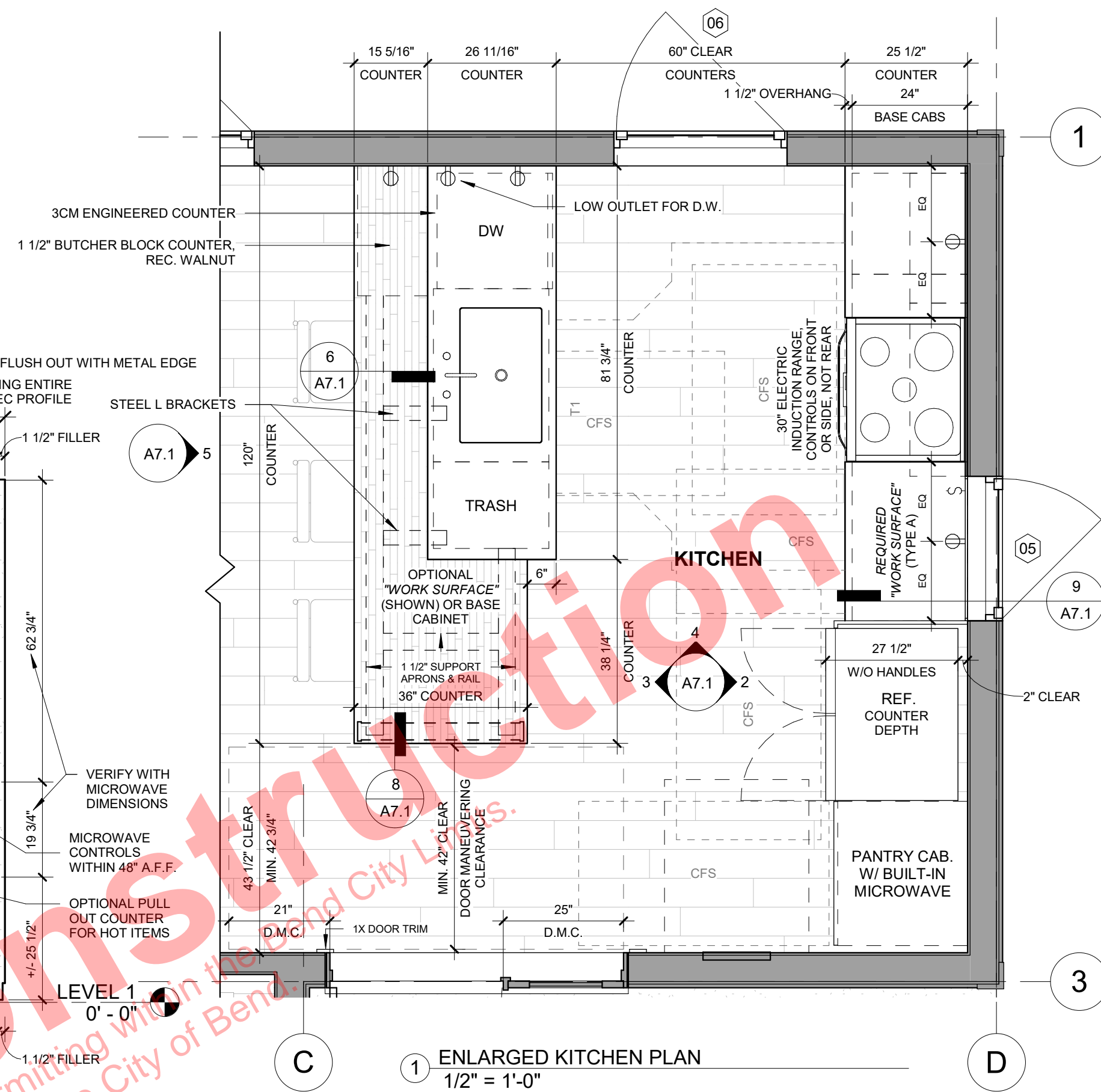

1 ENLARGED KITCHEN PLAN  
1/2" = 1'-0"

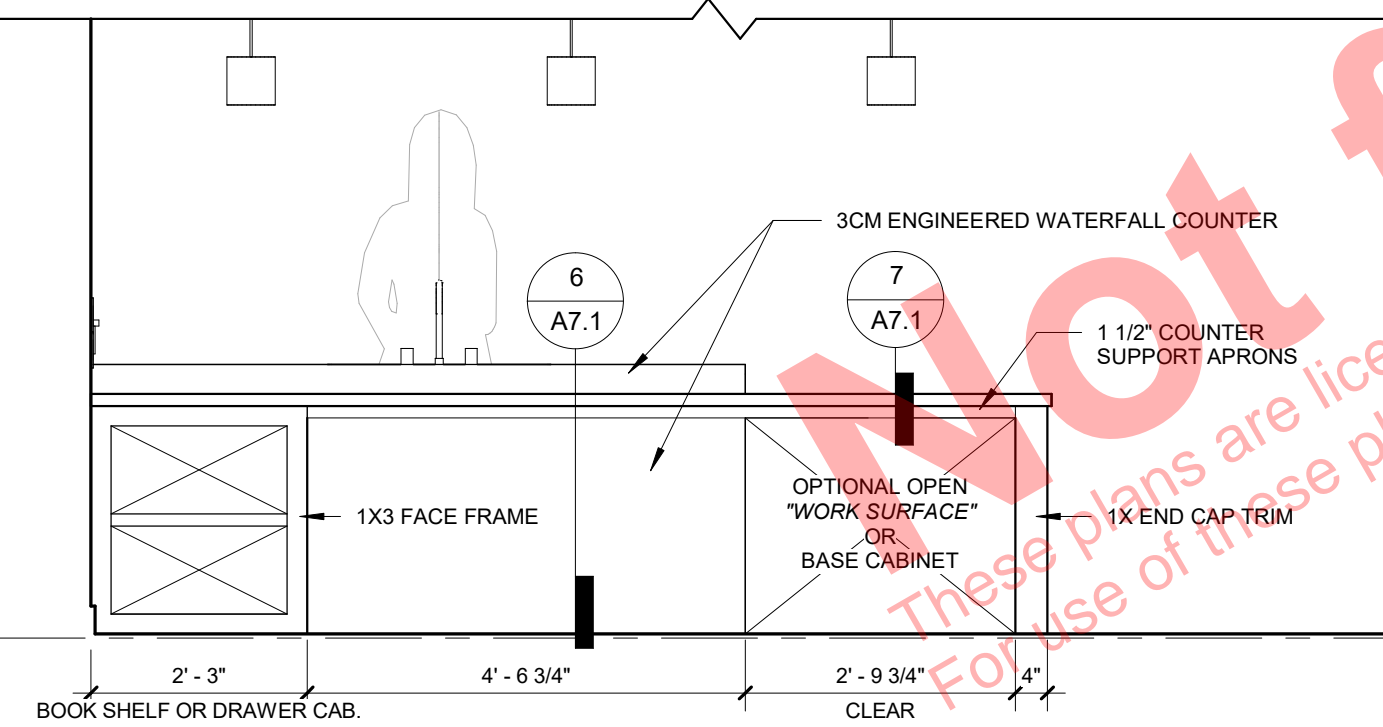

5 PENINSULA LEFT  
1/2" = 1'-0"

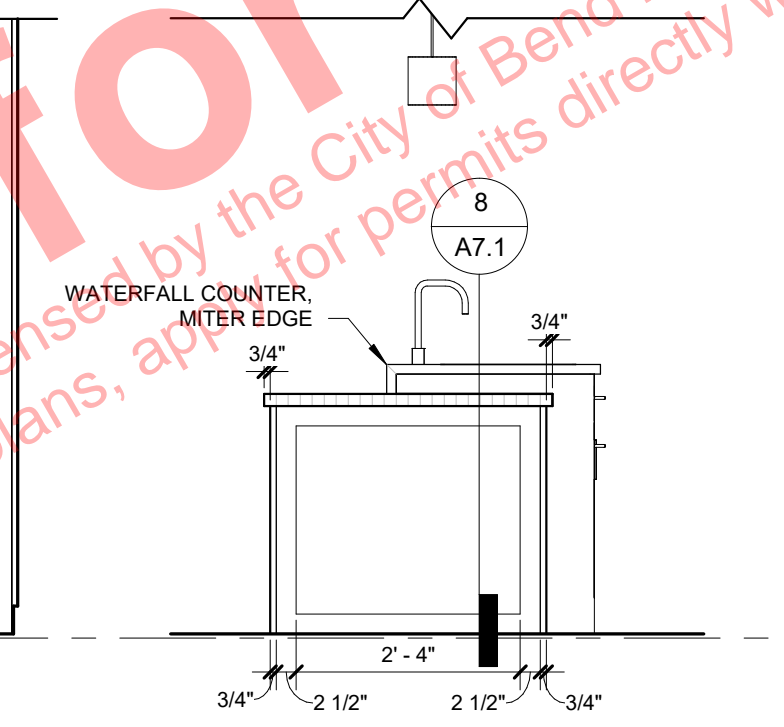

4 PENINSULA FRONT  
1/2" = 1'-0"

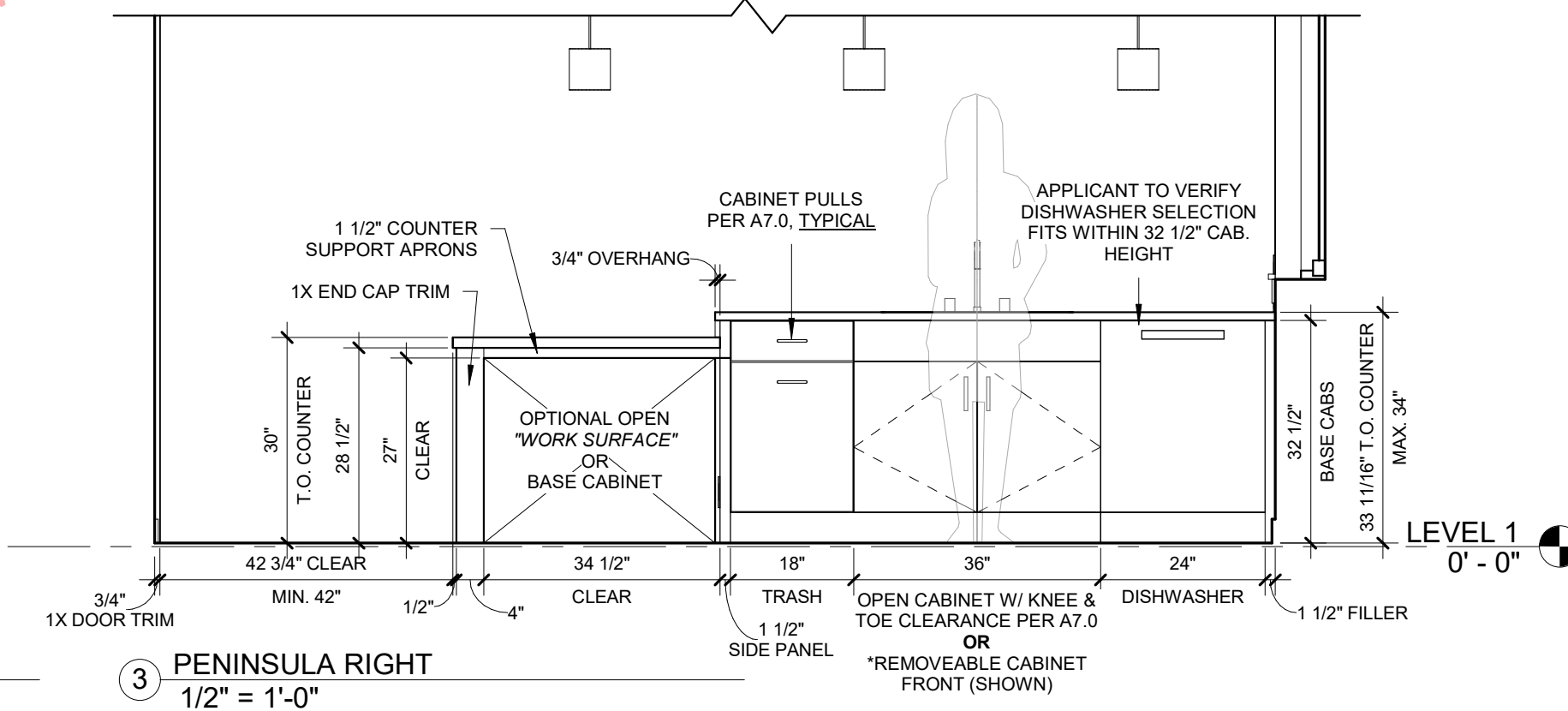

3 PENINSULA RIGHT  
1/2" = 1'-0"

**INTERIOR GENERAL NOTES**

- 1) DIMENSIONS ON THIS SHEET ARE TO FINISH FACE AND/OR CENTER OF FIXTURE, U.N.O.
- 2) ALL INTERIOR SPACES SHALL COMPLY WITH SHEET A7.0 FOR TYPE A.
- 3) OUTLETS AND SWITCHES TO BE DECORA WHITE, NYLON PLATE COVERS, TYPICAL.
- 4) INTERIOR DESIGN NOT INCLUDED IN ARCHITECT'S SCOPE OF WORK. APPLICANT IS RESPONSIBLE FOR SELECTING ALL FINISH MATERIALS, HARDWARE, FIXTURES AND APPLIANCES IN COMPLIANCE WITH THESE DRAWINGS. IF NO INTERIOR DESIGNER WILL BE USED, RECOMMEND ARCHITECT DOCUMENT INTERIOR SELECTIONS AS AN ADDITIONAL SERVICE.
- 5) RECOMMEND CHANGE IN COLOR CONTRAST AT CHANGES IN PLANE FOR VISUAL IMPAIRMENT. CHANGES IN COUNTER HEIGHT, COUNTER TO BACKSPASH, COUNTER TO SINK, COUNTER TO CABS, ETC.

**\*REMOVABLE CABINET FRONT NOTES**

- REMOVABLE CABINET FRONT MUST MEET THE FOLLOWING FOR TYPE A:
- A) THE CABINETRY CAN BE REMOVED WITHOUT REMOVAL OR REPLACEMENT OF THE SINK.
  - B) THE FLOOR FINISH EXTENDS UNDER THE CABINETRY, AND THE WALLS BEHIND AND SURROUNDING THE CABINETRY ARE FINISHED.
  - C) THE CABINETRY CAN BE REMOVED WITHOUT REMOVAL OR REPLACEMENT OF THE WORK SURFACE IF APPLICABLE.
  - D) ONCE REMOVED, KNEE & TOE CLEARANCES PER A7.0 ARE MET.
  - E) WATER SUPPLY AND DRAIN PIPES UNDER SINKS SHALL BE INSULATED OR OTHERWISE CONFIGURED TO PROTECT AGAINST CONTACT. THERE SHALL BE NO SHARP OR ABRASIVE SURFACES UNDER SINKS.
  - F) THERE SHALL BE NO SHARP OR ABRASIVE SURFACES UNDER THE EXPOSED PORTIONS OF WORK SURFACE.

**TYPICAL INTERIOR TRIM, U.N.O.**

- ALL INTERIOR TRIM TO BE PRIMED SOLID WOOD (FINGER JOINTED PINE OR SIM.) APPLICANT MAY CHOOSE SOLID STAIN GRADE TRIM INSTEAD.
- WINDOWS:** DRYWALL WRAP AT SIDES AND TOP OF WINDOWS, TYPICAL 1X PROJECTING SILL W/ 1/2"X4 APRON U.N.O. (KITCHEN & BATH WINDOW VARY) PER TYPICAL DETAIL 9/A7.2
- DOORS:** 1X4 FACE WRAP (TOP & SIDES)
- BASEBOARDS:** 1/2" X 4

JURISDICTION APPROVAL

REGISTERED ARCHITECT  
IAN BURGESS  
BEND, OREGON  
LIC # 6925  
STATE OF OREGON  
EXPIRES 12/31/2027



INTERIOR - KITCHEN

MASTER REISSUE PERMIT  
03/11/2026

(541) 306-3775  
INFO@SIERRA-JAMES.COM

DESCHUTES BUNGALOW

PROJECT ADDRESS

A7.1

**INTERIOR GENERAL NOTES**

- 1) DIMENSIONS ON THIS SHEET ARE TO FINISH FACE AND/OR CENTER OF FIXTURE, U.N.O.
- 2) ALL INTERIOR SPACES SHALL COMPLY WITH SHEET A7.0 FOR TYPE A.
- 3) OUTLETS AND SWITCHES TO BE DECORA WHITE, NYLON PLATE COVERS, TYPICAL
- 4) INTERIOR DESIGN NOT INCLUDED IN ARCHITECT'S SCOPE OF WORK. APPLICANT IS RESPONSIBLE FOR SELECTING ALL FINISH MATERIALS, HARDWARE, FIXTURES AND APPLIANCES IN COMPLIANCE WITH THESE DRAWINGS. IF NO INTERIOR DESIGNER WILL BE USED, RECOMMEND ARCHITECT DOCUMENT INTERIOR SELECTIONS AS AN ADDITIONAL SERVICE.
- 5) RECOMMEND CHANGE IN COLOR CONTRAST AT CHANGES IN PLANE FOR VISUAL IMPAIRMENT. CHANGES IN COUNTER HEIGHT, COUNTER TO BACKSPLASH, COUNTER TO SINK, COUNTER TO CABS, ETC.

**\*REMOVABLE CABINET FRONT NOTES**

- REMOVABLE CABINET FRONT MUST MEET THE FOLLOWING FOR TYPE A:
- THE CABINETS CAN BE REMOVED WITHOUT REMOVAL OR REPLACEMENT OF THE SINK.
  - THE FLOOR FINISH EXTENDS UNDER THE CABINETS, AND THE WALLS BEHIND AND SURROUNDING THE CABINETS ARE FINISHED
  - THE CABINETS CAN BE REMOVED WITHOUT REMOVAL OR REPLACEMENT OF THE WORK SURFACE IF APPLICABLE.
  - ONCE REMOVED, KNEE & TOE CLEARANCES PER A7.0 ARE MET
  - WATER SUPPLY AND DRAIN PIPES UNDER SINKS SHALL BE INSULATED OR OTHERWISE CONFIGURED TO PROTECT AGAINST CONTACT. THERE SHALL BE NO SHARP OR ABRASIVE SURFACES UNDER SINKS.
  - THERE SHALL BE NO SHARP OR ABRASIVE SURFACES UNDER THE EXPOSED PORTIONS OF WORK SURFACE.

**TYPICAL INTERIOR TRIM, U.N.O.**

- ALL INTERIOR TRIM TO BE PRIMED SOLID WOOD (FINGER JOINTED PINE OR SIM.) APPLICANT MAY CHOOSE SOLID STAIN GRADE TRIM INSTEAD.
- WINDOWS:** DRYWALL WRAP AT SIDES AND TOP OF WINDOWS, TYPICAL 1X PROJECTING SILL W/ 1/2"X4 APRON U.N.O. (KITCHEN & BATH WINDOW VARY)
- DOORS:** 1X4 FACE WRAP (TOP & SIDES)
- BASEBOARDS:** 1/2" X 4

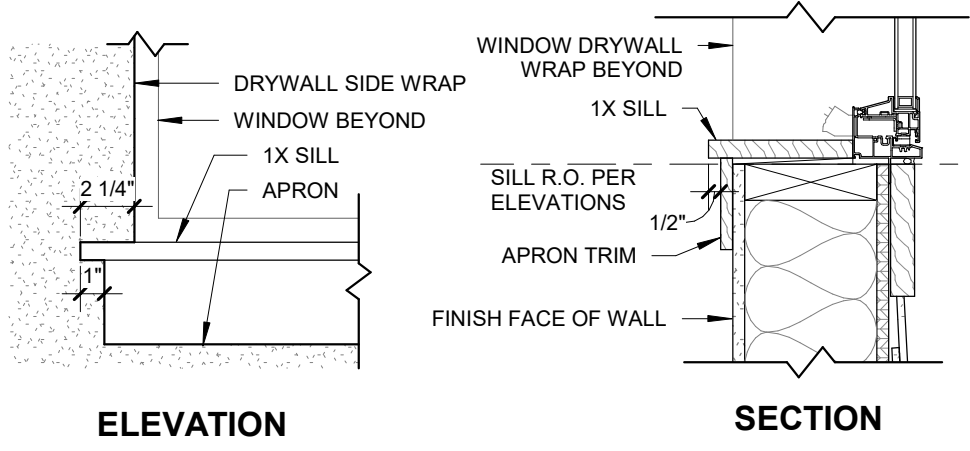

9 INTERIOR WINDOW TRIM DETAILS, TYPICAL  
1 1/2" = 1'-0"

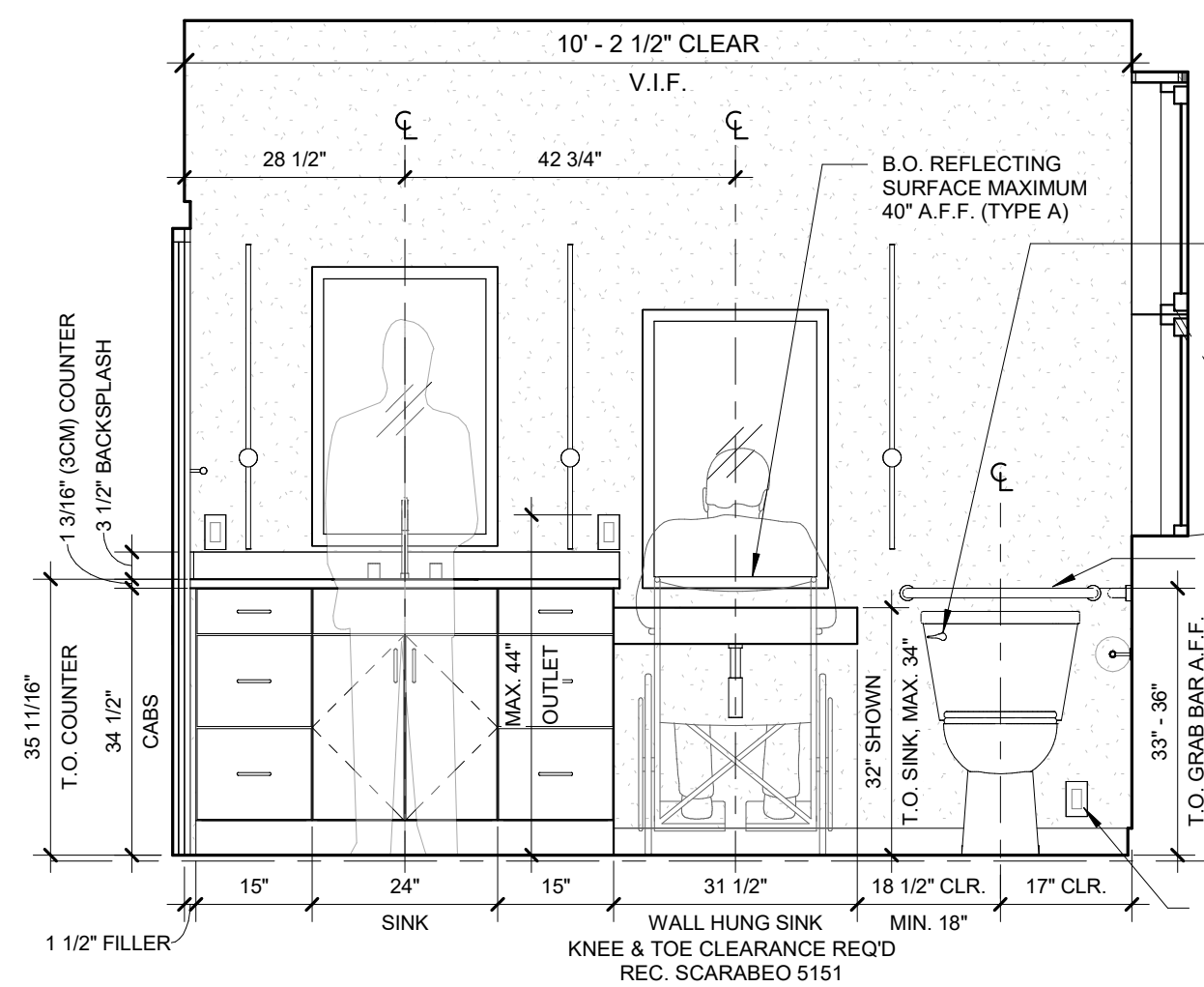

5 BATH BACK (OPTION 1A - DOUBLE SINK)  
1/2" = 1'-0"

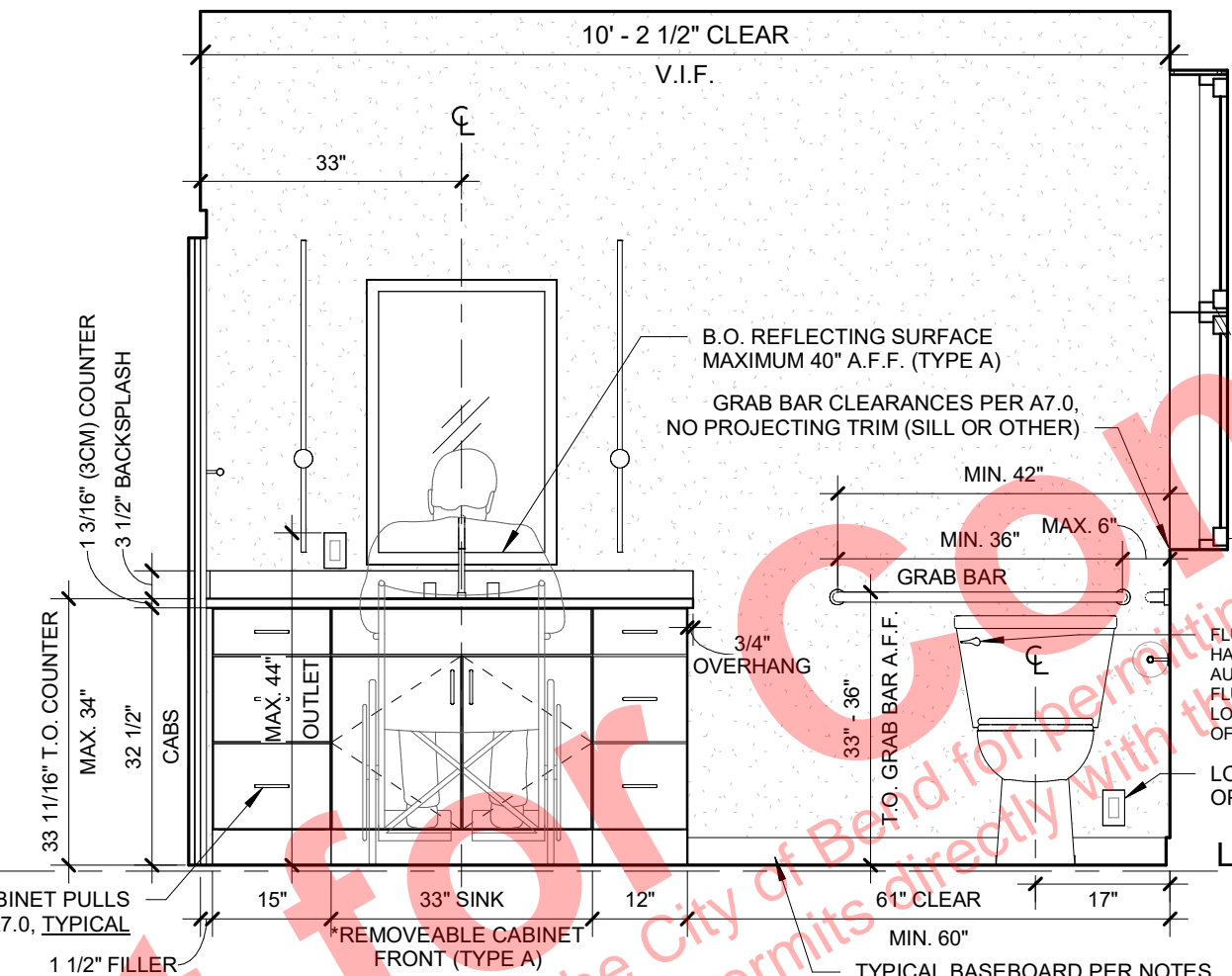

6 BATH BACK (OPTION 1B - SINGLE SINK)  
1/2" = 1'-0"

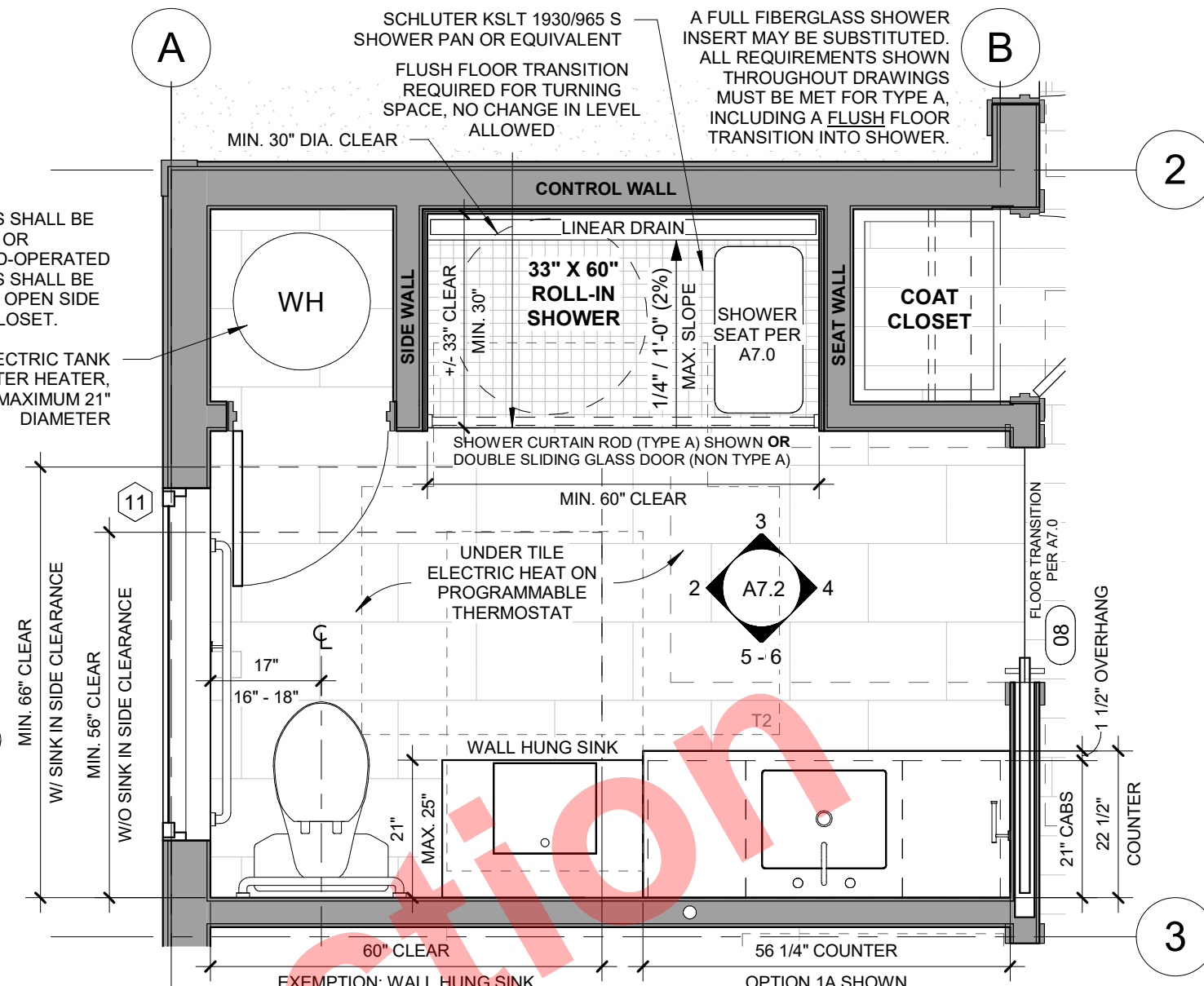

1 ENLARGED BATHROOM PLAN  
1/2" = 1'-0"

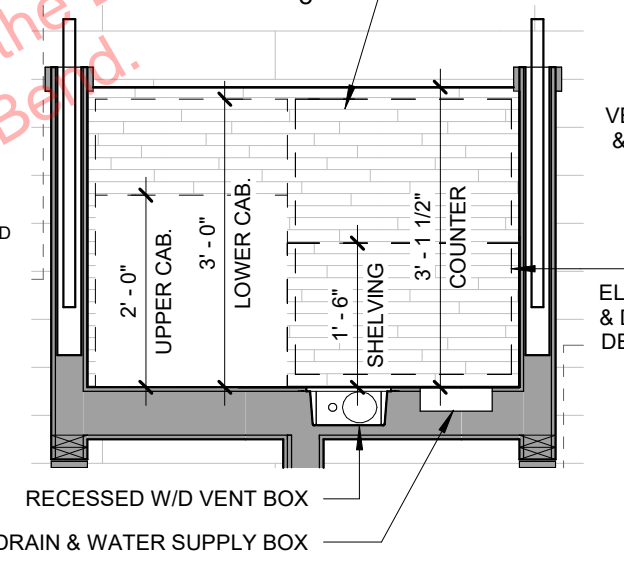

7 ENLARGED WASHER / DRYER LINEN PLAN  
1/2" = 1'-0"

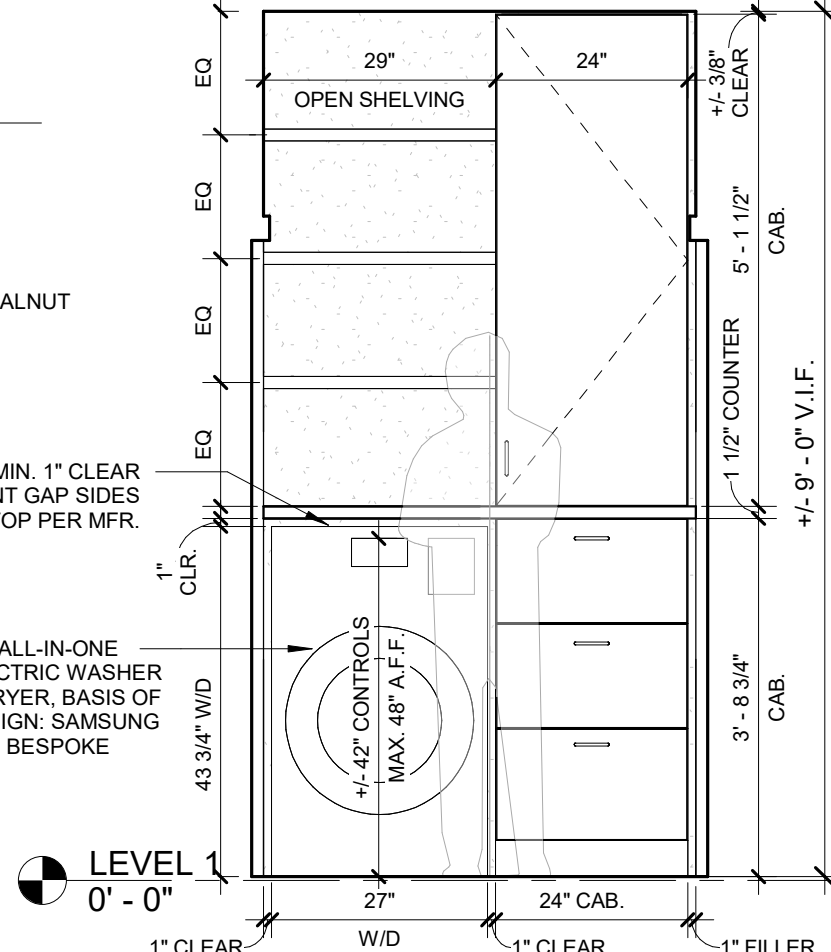

8 WASHER / DRYER / LINEN ELEVATION  
1/2" = 1'-0"

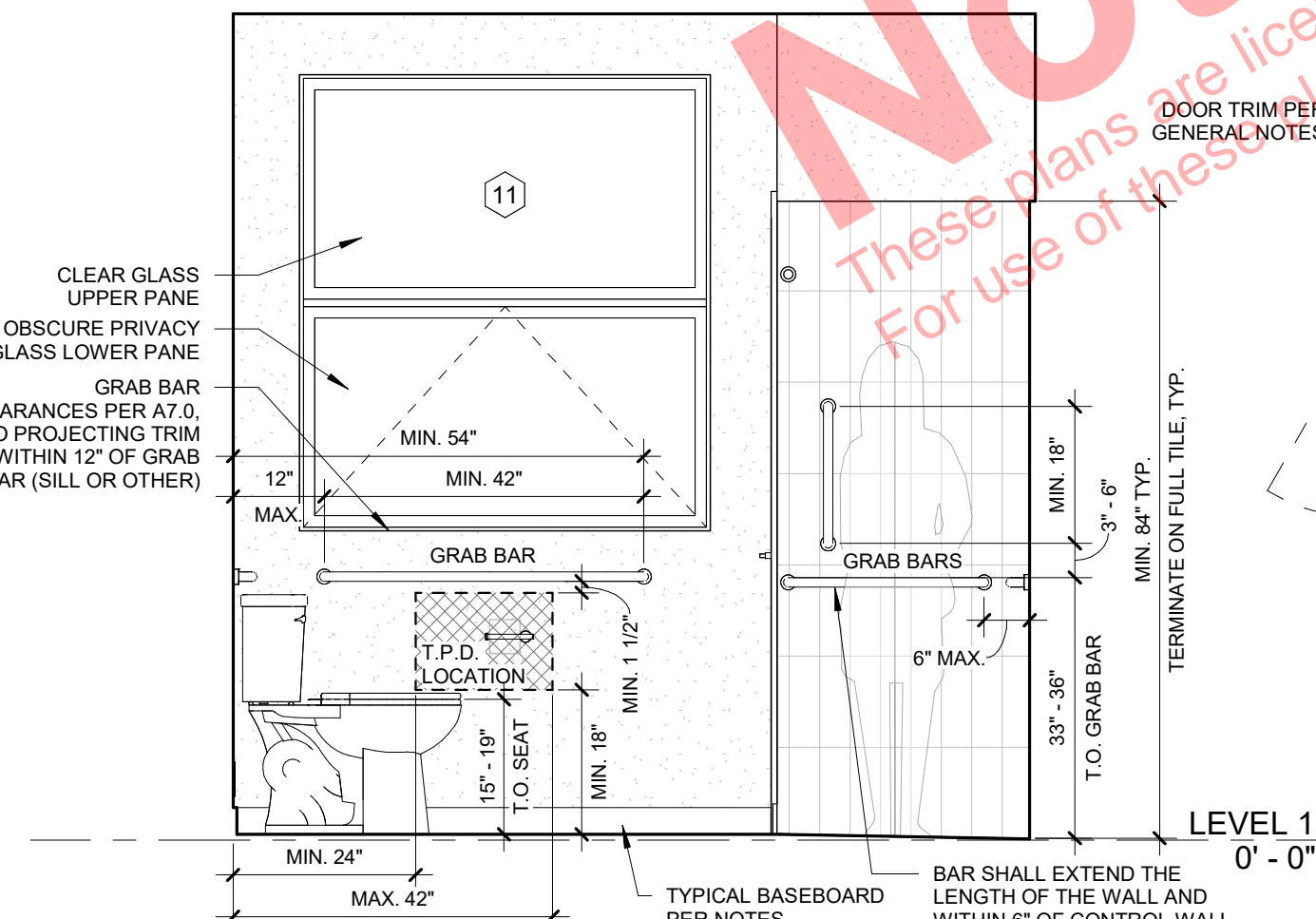

2 BATH LEFT  
1/2" = 1'-0"

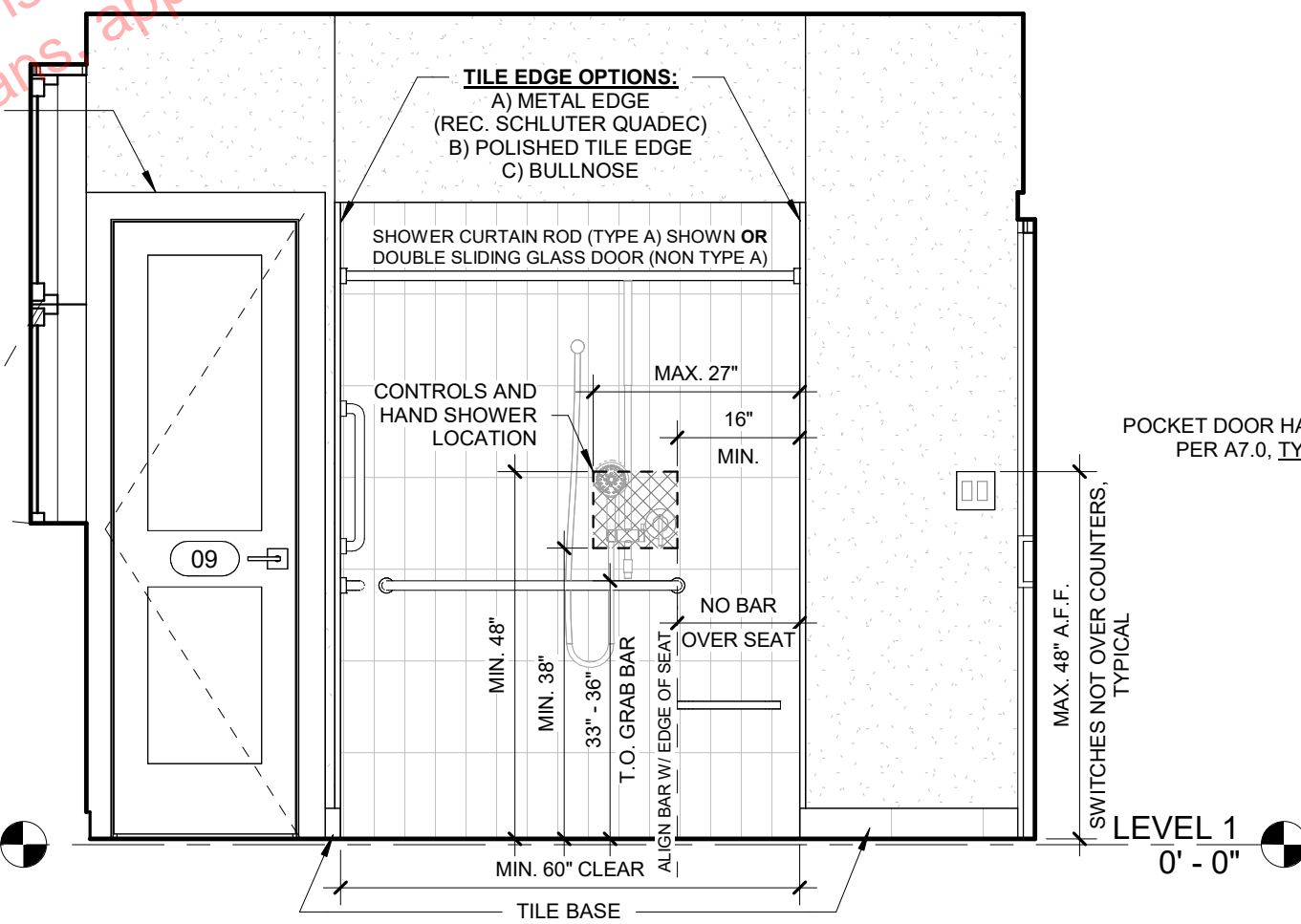

3 BATH FRONT  
1/2" = 1'-0"

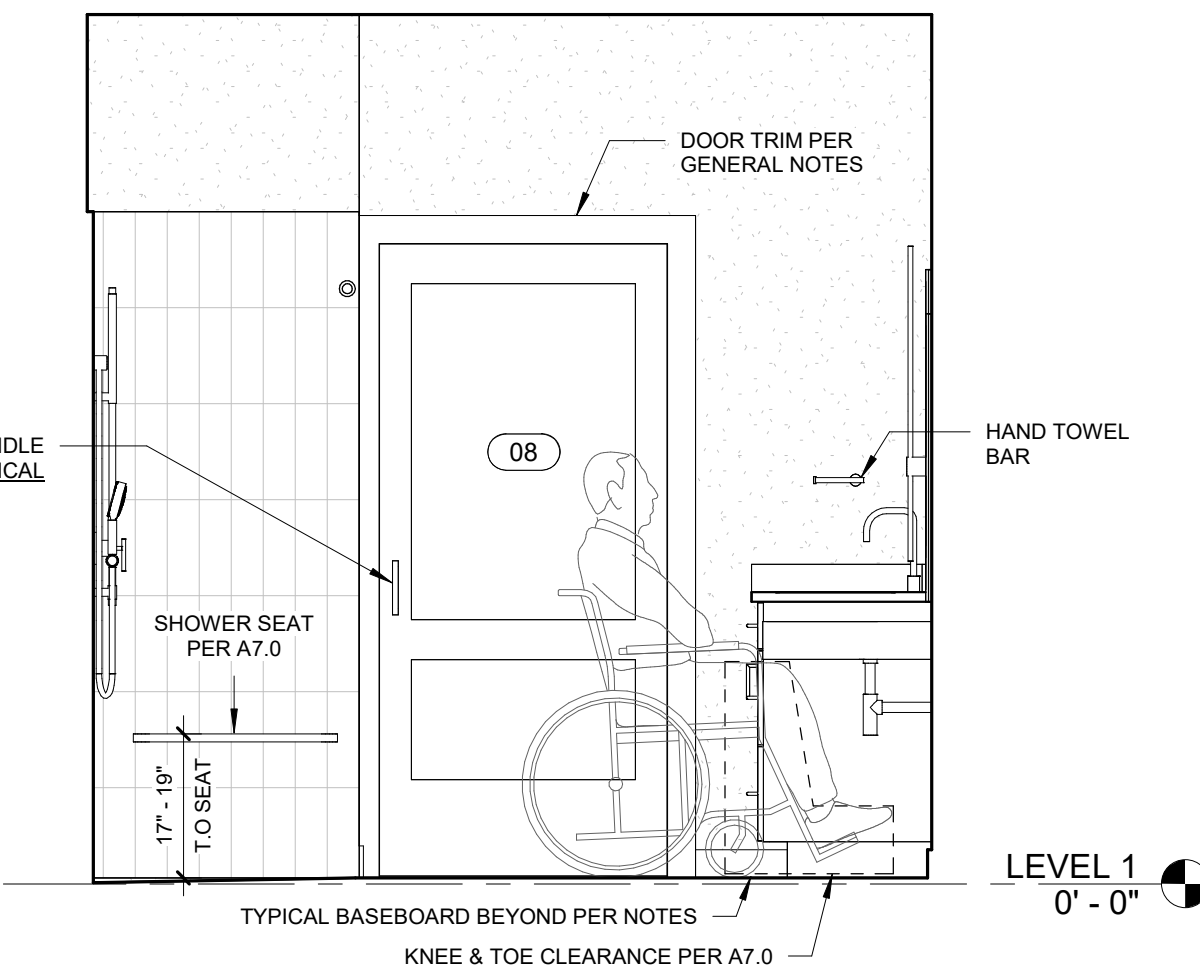

4 BATH RIGHT  
1/2" = 1'-0"

JURISDICTION APPROVAL

REGISTERED ARCHITECT  
IAN BURGESS  
BEND, OREGON  
LIC # 6925  
EXPIRES 12/31/2027

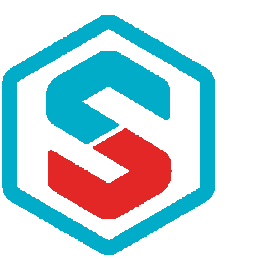

SIERRA JAMES



INTERIOR - BATHROOM & W/D

MASTER REISSUE PERMIT  
03/11/2026

DESCHUTES BUNGALOW

(541) 306-3775  
INFO@SIERRA-JAMES.COM

PROJECT ADDRESS

A7.2

**3D GENERAL NOTE**

3D DRAWINGS ARE DIAGRAMATIC AND NOT FOR CONSTRUCTION PURPOSES. FOR ORIENTATION AND REFERENCE ONLY. 2D DRAWINGS & SCHEDULES TAKE PRECEDENCE OVER 3D DRAWINGS. CONTACT ARCHITECT OF RECORD FOR CLARIFICATIONS IN LIEU OF USING 3D DRAWINGS FOR DESIGN OR CONSTRUCTION REASONS. 3D MODELING IS TO A LEVEL OF DEVELOPMENT 200 PER THE AIA.

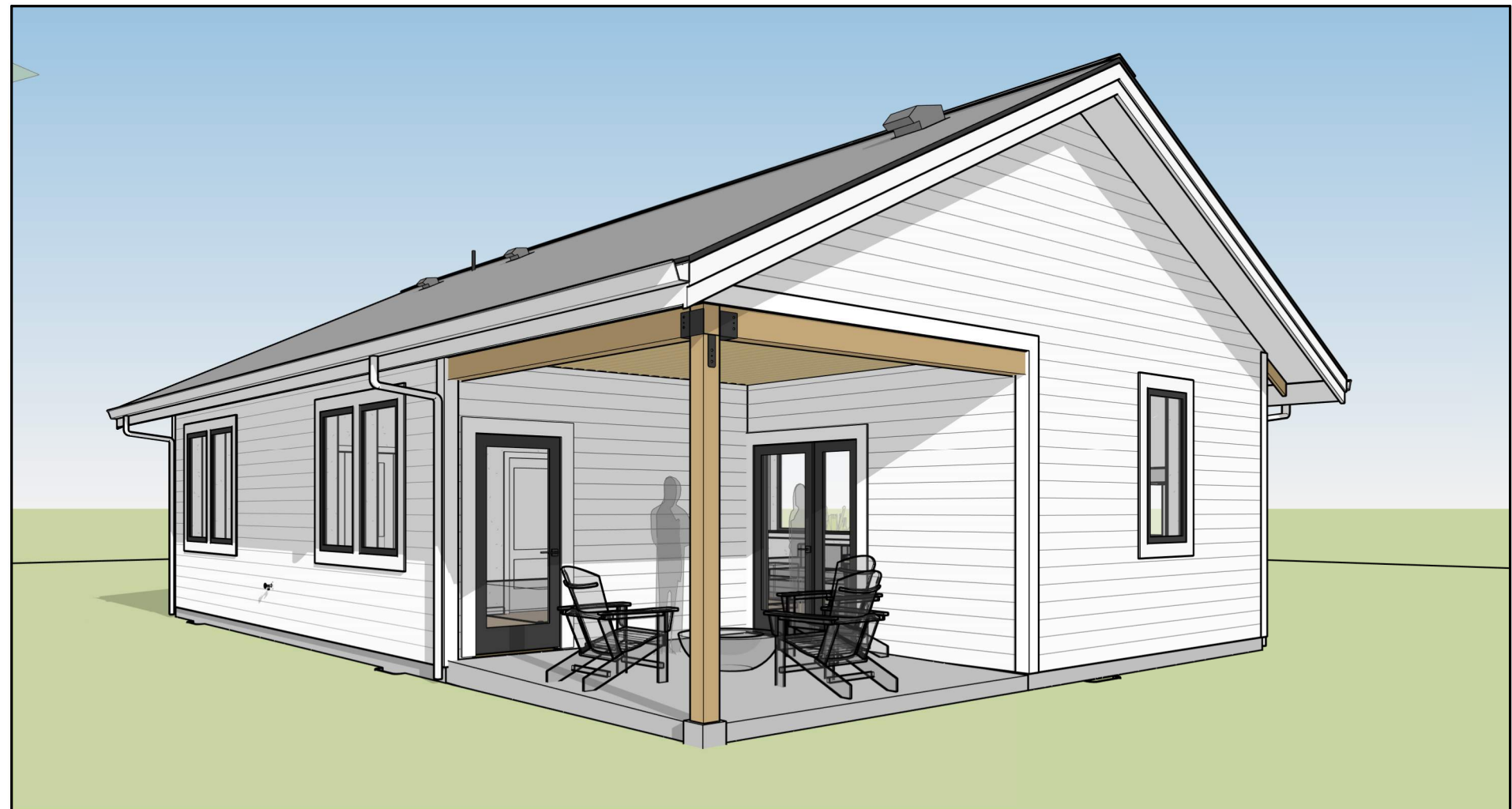
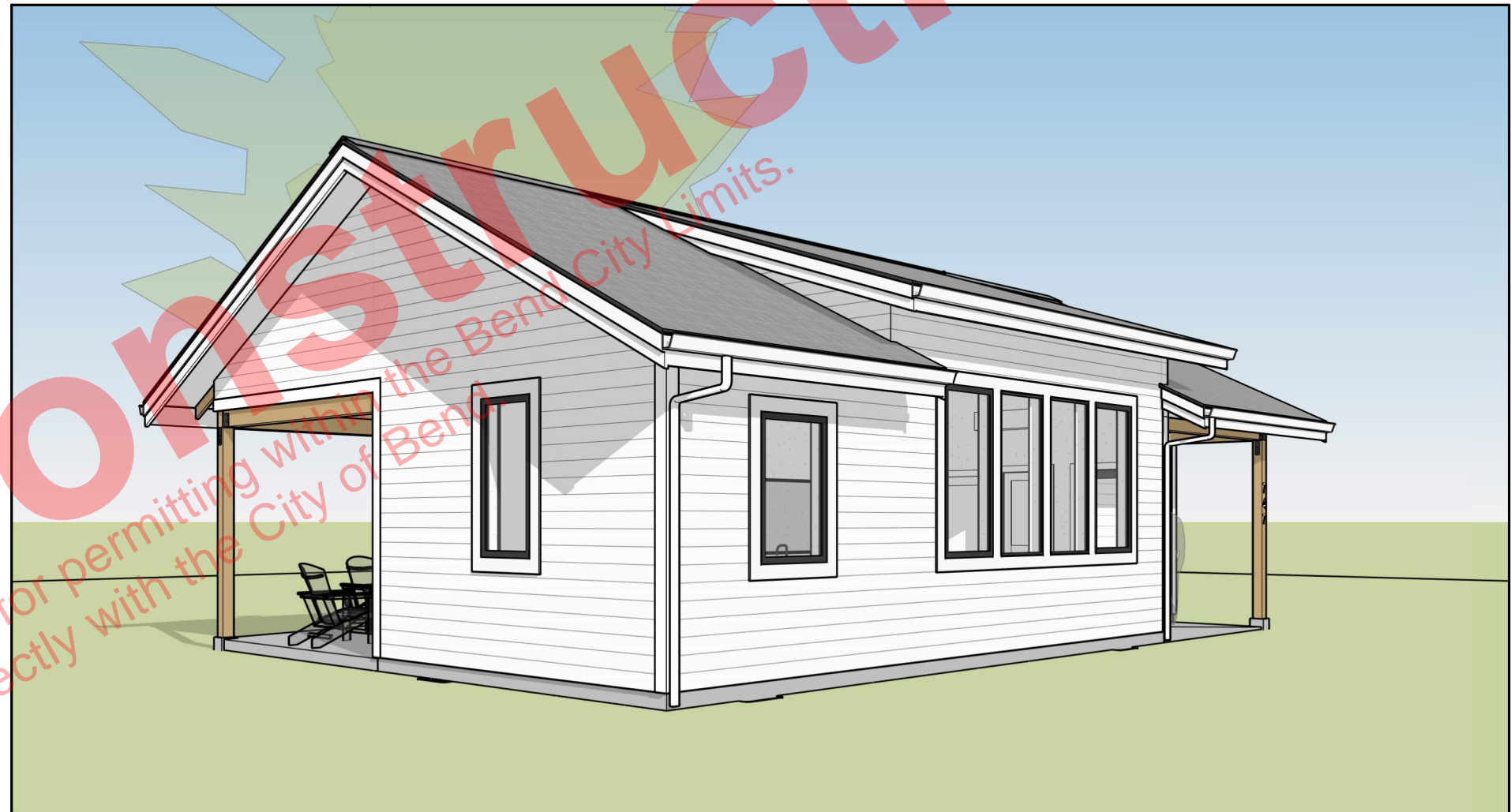
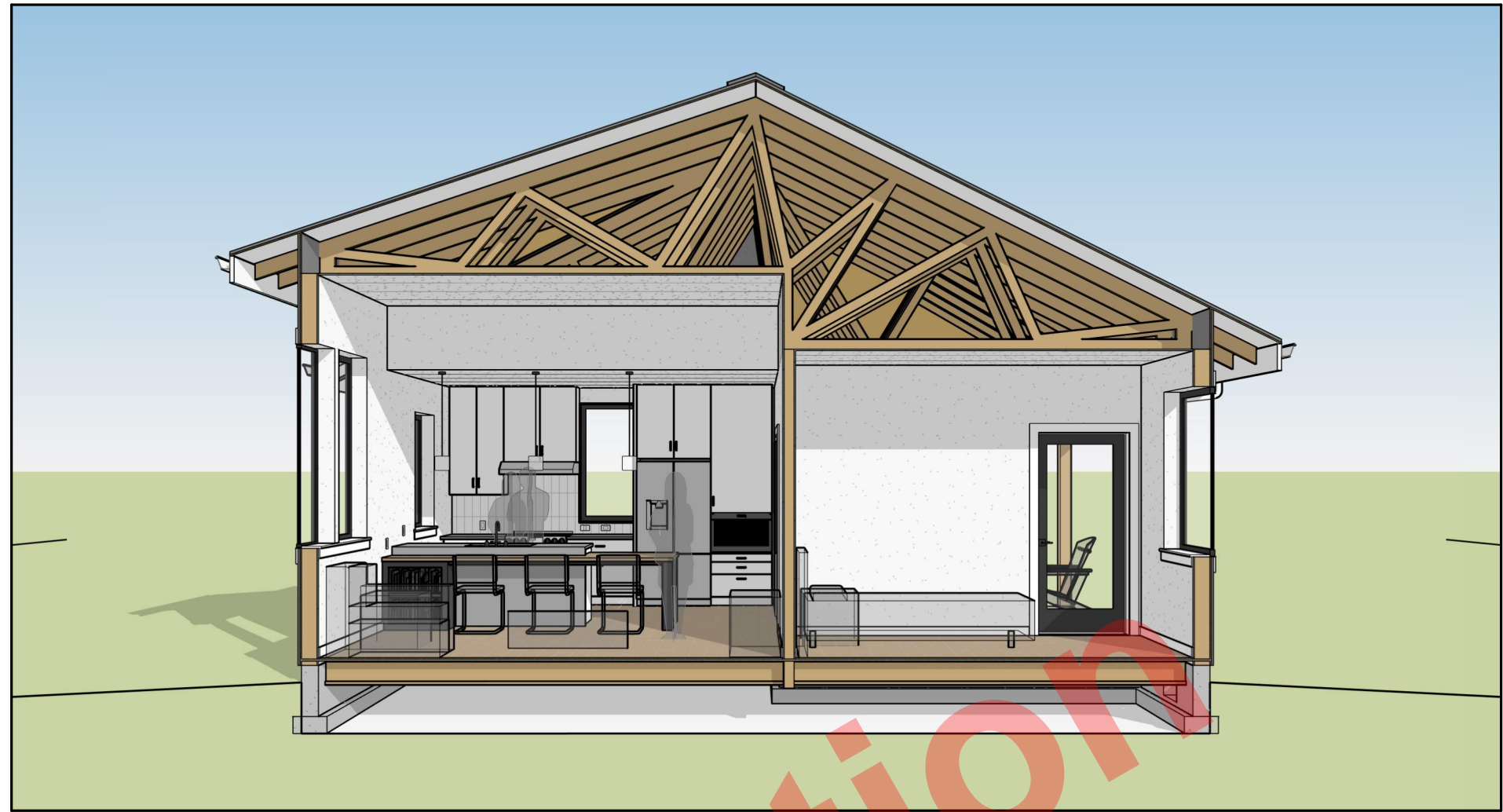
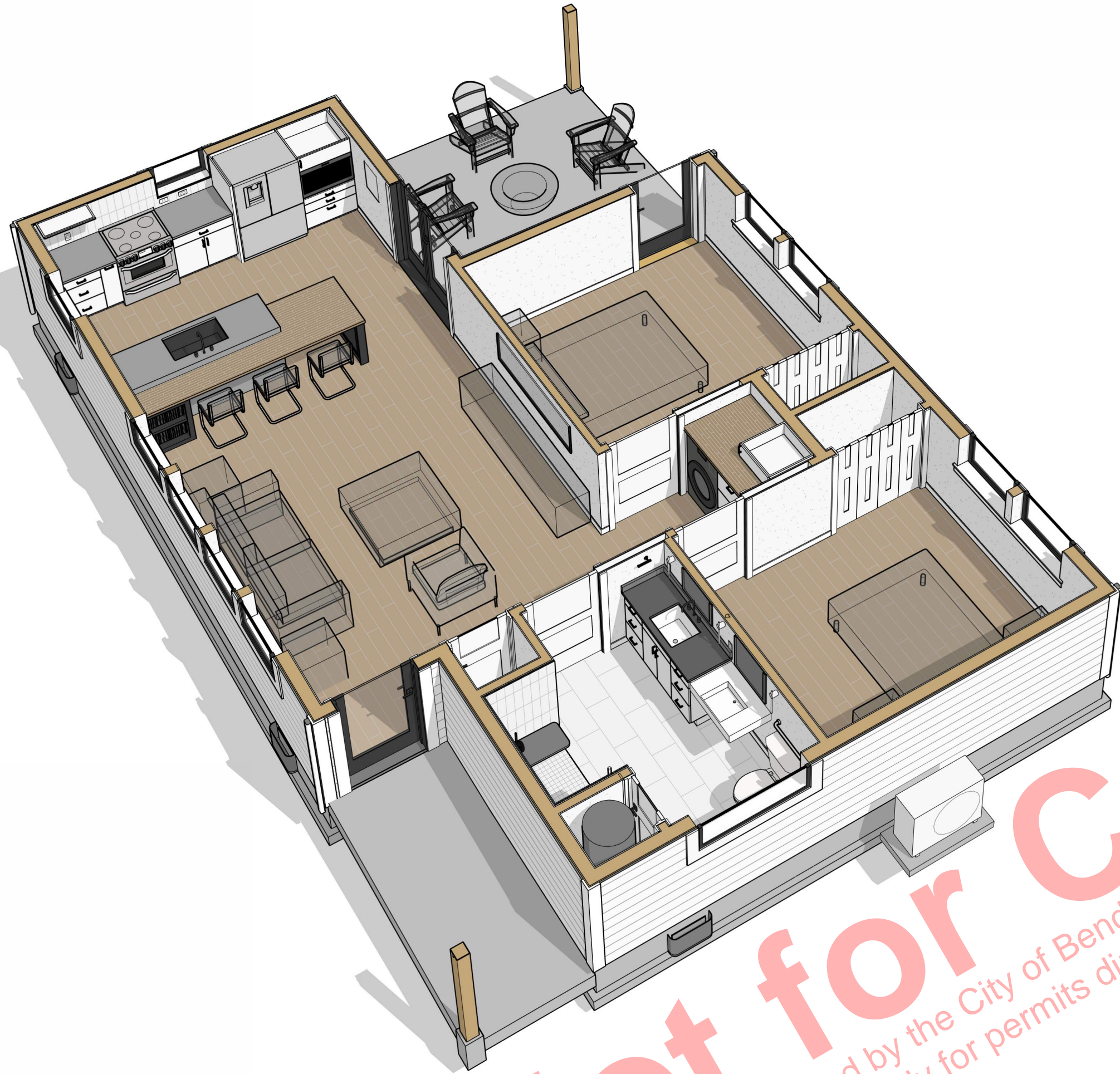

JURISDICTION APPROVAL

REGISTERED ARCHITECT  
 IAN BURGESS  
*Ian Burgess*  
 BEND, OREGON  
 LIC # 6925  
 STATE OF OREGON

EXPIRES 12/31/2027



**SIERRA JAMES**



3D VIEWS - EXTERIOR

MASTER REISSUE PERMIT  
 03/11/2026

(541) 306-3775  
 INFO@SIERRA-JAMES.COM

**DESCHUTES BUNGALOW**

PROJECT ADDRESS

**A9.1**

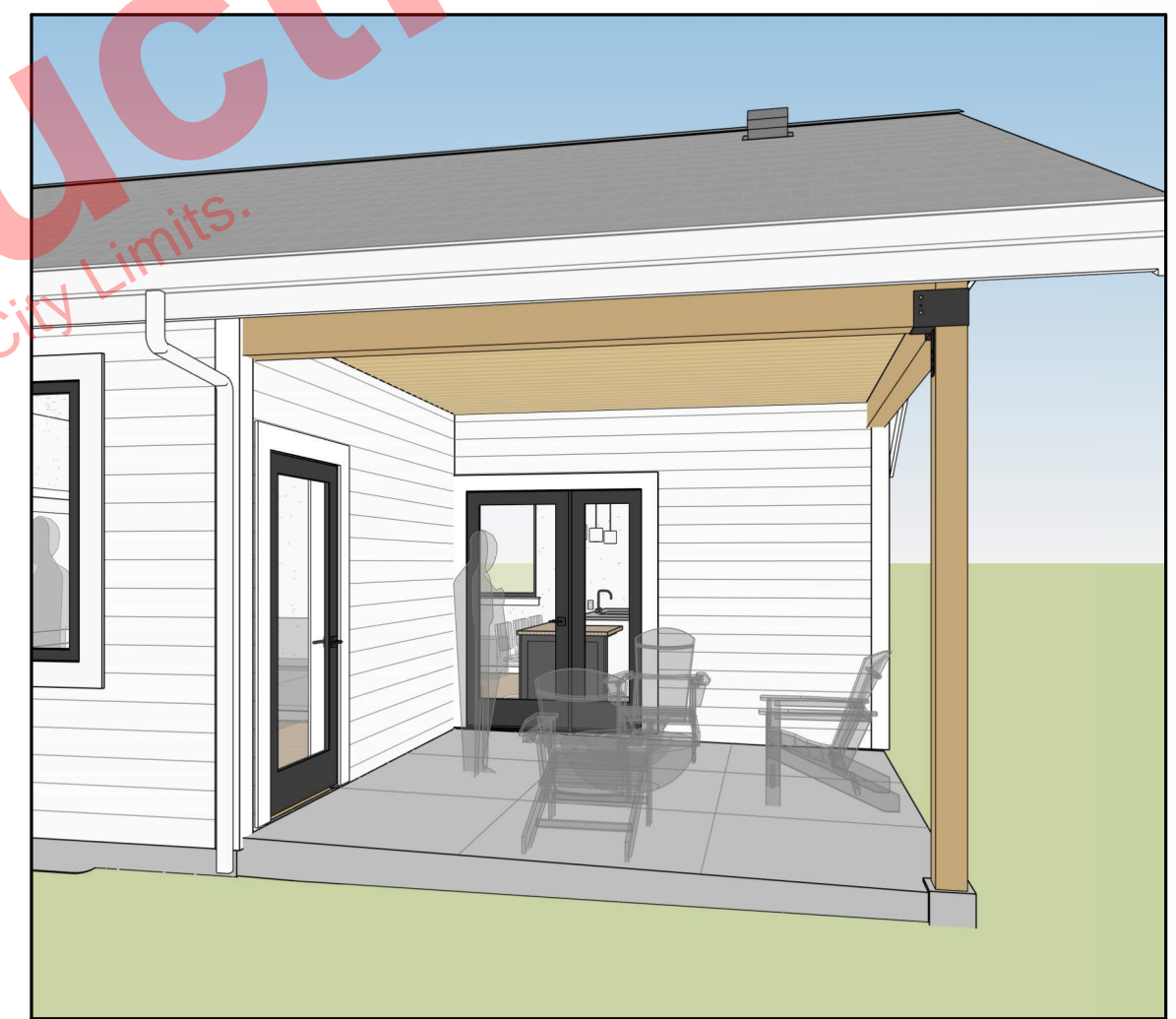

JURISDICTION APPROVAL

REGISTERED ARCHITECT  
IAN BURGESS  
*Ian Burgess*  
BEND, OREGON  
LIC # 6925  
STATE OF OREGON

EXPIRES 12/31/2027



SIERRA  
JAMES



3D VIEWS - INTERIOR

MASTER REISSUE PERMIT  
03/11/2026

(541) 306-3775  
INFO@SIERRA-JAMES.COM

DESCHUTES BUNGALOW

PROJECT ADDRESS

A9.2

Not for Construction  
These plans are licensed by the City of Bend for permitting within the Bend City Limits.  
For use of these plans, apply for permits directly with the City of Bend.

**WALL FOOTING SCHEDULE**

MARK	WIDTH	FOUNDATION THICKNESS	STEM WIDTH	FOOTING REBAR	STEM REBAR
WF1	12"	6"	6"	2-#4(G40) HORIZ REBAR	1-#4(G40)HORIZ REBAR <6" FROM TOP, 1-#4(G40) VERT REBAR AT 48" O.C.

**SPREAD FOOTING SCHEDULE**

MARK	WIDTH	LENGTH	FOOTING THICKNESS	REBAR SCHEDULE	POST BASE
F1	28"	28"	12"	4-#4(G40) REBAR E.W.	ABU OPT
TF18-18	18"	18"	18"	2-#4(G40) REBAR E.W.	CPTZ66
TF24-12	24"	24"	12"	2-#4(G40) REBAR E.W.	ABU OPT
TF24-18	24"	24"	18"	2-#4(G40) REBAR E.W.	CPTZ66

**HOLD DOWN SCHEDULE**

MARK	HOLD DOWN	ANCHOR	SCREW OPTION	EPOXY ANCHOR OPTION	COUNT
SHB1	HDUE3	SABR5/8X24	5/8" TITENHD W/ 4" EMBEDDMENT	5/8" ATR W/ 6" EMBEDDMENT	2

WIND SPEED, EXPOSURE, SNOW LOAD AND SDS MAY NOT BE EXCEEDED. CONTACT ENGINEER FOR REDESIGN IF LOCATION EXCEEDS THESE VALUES.

**VARIABLE TABLE**

VARIABLE	VALUE	CODE REFERENCE
WIND SPEED	99 MPH, EXP C	[IBC-ASCE7-16]
GROUND SNOW LOAD	50 PSF	[SEAO-ASCE7-16]
SEISMIC	0.38g	[ASCE7-16]
FROST DEPTH	18"	[ORSC R301.2]

PLAN EVALUATED: SJC "Deschutes Bungalow"

**WALL FOOTING POINT LOAD CAPACITIES (1500 PSI SOIL BEARING)**

TYPE	MIN STEM WALL HEIGHT	MIN STEM WALL HEIGHT
12" WALL FTG	1'-6"	6000#
16" WALL FTG	1'-6"	7800#
18" WALL FTG	1'-6"	9000#
21" WALL FTG	1'-6"	10500#
24" WALL FTG	1'-6"	12000#
12" STRIP FTG	N/A	4500#
16" STRIP FTG	N/A	5850#
18" STRIP FTG	N/A	6750#
21" STRIP FTG	N/A	7875#
24" STRIP FTG	N/A	9000#

**FOUNDATION NOTES:**

- BUILDING IS REQUIRED TO MEET MINIMUM SETBACK REQUIREMENTS (SITE PLAN)
- FINISH GRADE SHALL SLOPE AWAY FROM FOUNDATION WALLS (OR SIDEWALKS AND SLABS ADJACENT TO FOUNDATION WALLS).
- CONCRETE SHALL HAVE A MINIMUM COMPRESSIVE STRENGTH OR 2500 PSI (DEFAULT) OR AS SPECIFIED IN THE ENGINEERING.
- EXTERIOR FOOTINGS SHALL EXTEND BELOW THE FROST DEPTH FOR THE SITE. REF IRC TABLE R301.2(1)
- FOUNDATION WALLS SHALL EXTEND AT LEAST 6" ABOVE THE FINISHED GRADE.
- FOUNDATION DESIGN ASSUMES 1500 PSF SOIL BACK PRESSURE (CODE DEFAULT). USE OF SOIL PRESSURES GREATER THAN 1500 PSF REQUIRES SOIL TEST.
- FOUNDATION REINFORCEMENT AS SPECIFIED ON THIS PLAN.
- FOUNDATION REBAR SHALL HAVE A MINIMUM 24" LAP SPICE OR AS SPECIFIED ON THIS PLAN.
- FOUNDATION FOOTING SIZES AS SPECIFIED ON THIS PLAN.
- SILL PLATE SHALL BE PRESSURE TREATED AND ANCHORED TO STEM WALL USING ANCHOR BOLTS AS SPECIFIED IN THE SHEAR PLAN.
- DRAINS SHALL BE PROVIDED AROUND ALL CONCRETE OR MASONRY FOUNDATIONS ENCLOSING HABITABLE OR USABLE SPACES LOCATED BELOW GRADE.
- FOUNDATION VENTILATION SHALL BE A MINIMUM 1 SF VENT SPACE FOR EACH 150 SF OF UNDERFLOOR AREA AND VENTS SET WITHIN 3' EACH CORNER. (1/1500 W/6 MIL VAPOR BARRIER-IRC R408.1).
- PROVIDE A MINIMUM 18"x24" ACCESS OPENING TO UNDER FLOOR CRAWL SPACE, IF THE FURNACE IS INSTALLED IN THE CRAWL SPACE, THE OPENING MUST BE LARGE ENOUGH TO REMOVE THE LARGEST PIECE OF EQUIP. BUT NOT LESS THAN 30"x30". FLOOR ACCESS SHALL BE WITHIN 20' OF PLUMBING CLEANOUT. NO PIPE OR DUCTWORK SHALL INTERFERE WITH ACCESSIBILITY.
- FOOTINGS TO BEAR ON UNDISTURBED LEVEL SOIL DEVOID OF ANY ORGANIC MATERIAL AND STEPPED AS REQUIRED TO MAINTAIN A MINIMUM FROST DEPTH BELOW FINISHED GRADE.
- PROVIDE GROUND COVER OF 6 MIL BLACK POLYETHYLENE OR EQUAL LAPPED 12" AT ALL JOINTS AND TURNED UP 12" UP THE FOUNDATION WALL IN THE CRAWL SPACE. PROVIDE 6 MIL BLACK POLYETHYLENE UNDER CONCRETE SLABS.
- PROVIDE SILL SEAL BETWEEN THE WALL AND FOUNDATION WHERE FOUNDATION WALL ENCLOSES HEATED SPACE.
- PROVIDE ON #4 REBAR TIED TO THE FOUNDATION REBAR AND EXTENDED 12" ABOVE THE STEM WALL FOR GROUND ROD.
- COLUMN BASES SHALL BE PROTECTED AGAINST DECAY OR CORROSION UNLESS PRESSURE TREATED WOOD IS USED. STEEL POST BASES SHALL BE GALVANIZED AND BE SIZED TO COVER THE ENTIRE BOTTOM OF THE COLUMN.
- CONCRETE SLABS MIN 2500 PSI W/OPTIONAL W6SX6 10/10WW MESH OR APPROVED FIBER MESH. USE EXPANSION JOINTS OR SAW CUT AT MIN 12' O.C. SLOPE GARAGE SLABS MIN 1/8/12 TOWARD DOORS.
- ALL EXTERIOR WALLS, BEARING WALLS, COLUMNS AND PIERS SHALL BE SUPPORTED ON CONTINUOUS SOLID MASONRY OR CONCRETE FOOTINGS AND SHALL EXTEND BELOW THE FROST DEPTH. FOOTINGS SHALL BEAR ON UNDISTURBED SOIL OR 4" GRANULAR MATERIAL COMPACTED TO 95%.
- BEAM POCKETS IN STEM WALLS TO HAVE 1/2" AIR SPACE AT SIDES AND END, AND A MINIMUM BEARING OF 4".
- REF SHEAR DIAGRAM FOR ANCHOR BOLT SPACING.

**SITE SLOPE AND FOUNDATION**

STEMWALL MAXIMUM HEIGHT IS 4' MEASURED FROM GRADE. STEMWALL UNBALANCED LOAD MAXIMUM HEIGHT IS 4'. IF EITHER CONDITION IS EXCEEDED CONTACT LICENSED STRUCTURAL ENGINEER.

**DEVIATION STATEMENT**

ANY DEVIATION FROM ARCHITECTURAL OR STRUCTURAL PLAN REQUIRES REVIEW BY LICENSED ENGINEER.

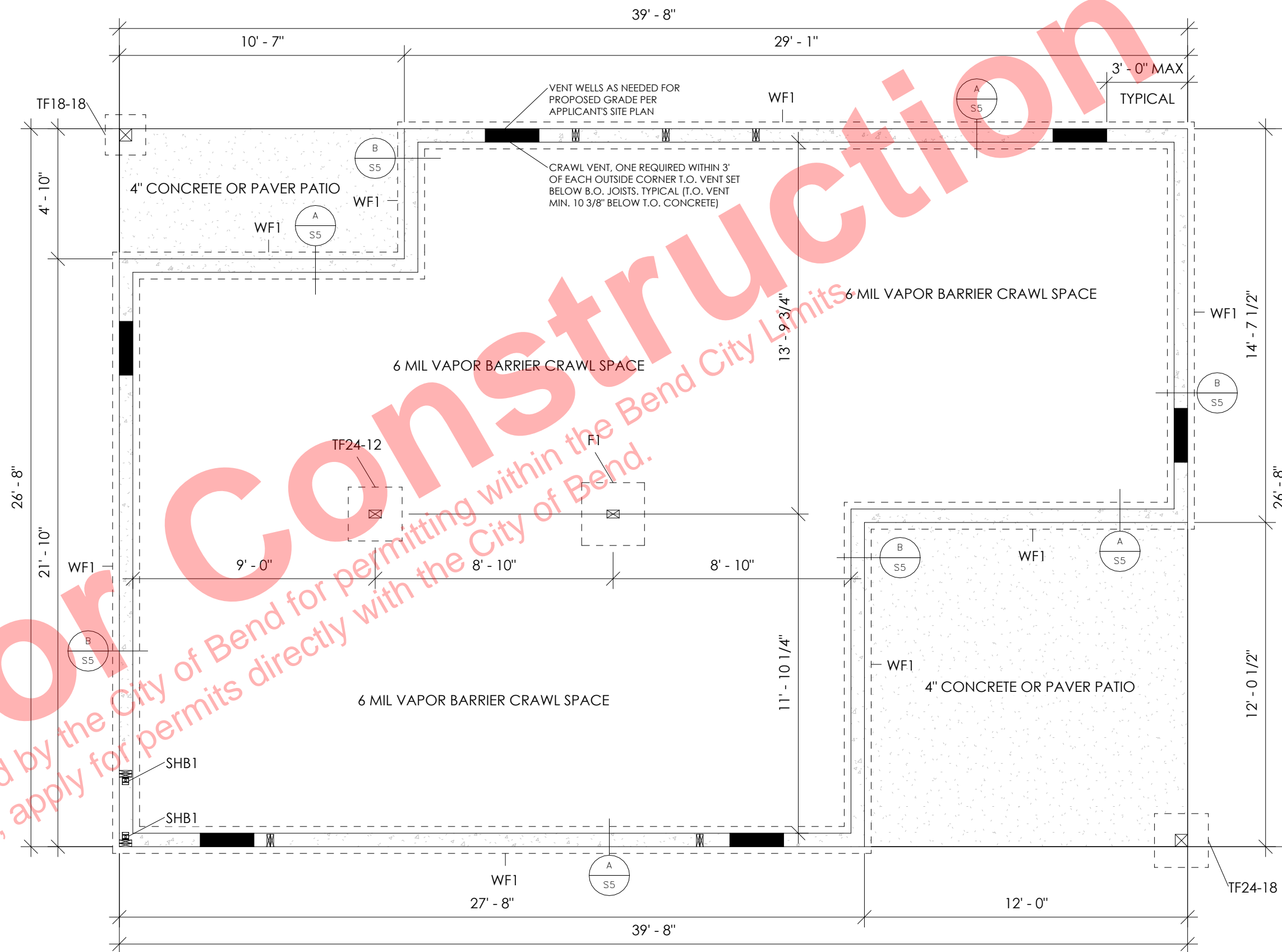

**FOUNDATION**

1/4" = 1'-0"

**Garrett J. Banton, PE**  
3008 NE Charleston Ct.  
Bend, OR 97701  
Phone: (541) 306-7893  
team@bantoneengineering.com



DESCHUTES BUNGALOW  
CITY OF BEND LIMITS

FOUNDATION

FILE:  
SCALE: As indicated  
DATE: 3/6/26

**DEVIATION STATEMENT**  
 ANY DEVIATION FROM ARCHITECTURAL OR STRUCTURAL  
 PLAN REQUIRES REVIEW BY LICENSED ENGINEER.



EXPIRES: 12/31/2027

**Garrett J. Banton, PE**  
 3008 NE Charleston Ct.  
 Bend, OR 97701  
 Phone: (541) 306-7893  
 team@bantoneengineering.com



DESCHUTES BUNGALOW  
 CITY OF BEND LIMITS

SUBFLOOR  
 FRAMING

FILE:  
 SCALE: 1/4" = 1'-0"  
 DATE: 3/6/26

S2

WIND SPEED, EXPOSURE, SNOW LOAD AND SDS  
 MAY NOT BE EXCEEDED. CONTACT ENGINEER FOR  
 REDESIGN IF LOCATION EXCEEDS THESE VALUES.

**VARIABLE TABLE**

VARIABLE	VALUE	CODE REFERENCE
WIND SPEED	99 MPH, EXP C	[IBC-ASCE7-16]
GROUND SNOW LOAD	50 PSF	[SEAO-ASCE7-16]
SEISMIC	0.38g	[ASCE7-16]
FROST DEPTH	18"	[ORSC R301.2]

PLAN EVALUATED: SJC "Deschutes Bungalow"

**O LEVEL BEAMS**

MARK	LENGTH	SIZE & MATERIAL
OFB1	27.5'	3-1/2"x9-1/2" 1.55E-2325Fb LSL

**FLOOR JOIST SPECIFICATIONS**

MANUFACTURER	TYPE
BOISE CASCADE (BCI)	9-1/2" BCI-4500s1.8
SIMPSON STRONG-TIE (TJI)	9-1/2" TJI 110
LP SOLIDSTART (LPI)	9-1/2" LPI 18
ROSEBURG (RFPI)	9-1/2" RFPI 20

**FLOOR FRAMING NOTES**

- SILL PLATE SHALL BE PRESSURE TREATED AND ANCHORED TO STEM WALL USING ANCHOR BOLTS AS SPECIFIED IN THE SHEAR PLAN.
- PROVIDE A MINIMUM 18" X24" CLEAR ACCESS OPENING TO UNDER FLOOR CRAWL SPACE. IF THE FURNACE IS INSTALLED IN THE CRAWL SPACE, THE OPENING MUST BE LARGE ENOUGH TO REMOVE THE LARGEST PIECE OF EQUIPMENT BUT NO LESS THAN 30" X30". FLOOR ACCESS SHALL BE WITHIN 20' OF PLUMBING CLEANOUT. NO PIPE OR DUCTWORK SHALL INTERFERE WITH ACCESSIBILITY.
- PROVIDE GROUND COVER OF 6 MIL BLACK POLYETHYLENE OR EQUAL LAPPED 12" AT ALL JOINTS AND TURNED UP 12" UP THE FOUNDATION WALL IN THE CRAWL SPACE. PROVIDE 6 MIL BLACK POLYETHYLENE UNDER CONCRETE SLABS.
- PROVIDE SILL SEAL BETWEEN THE WALL AND FOUNDATION WHERE THE FOUNDATION WALL ENCLOSES HEATED SPACE.
- ALL EXTERIOR WALLS, BEARING WALLS, COLUMNS, AND PIERS SHALL BE SUPPORTED ON CONTINUOUS SOLID MASONRY OR CONCRETE FOOTINGS AND SHALL EXTEND BELOW THE FROST DEPTH. FOOTINGS SHALL BEAR ON UNDISTURBED SOIL OR 4" GRANULAR MATERIAL COMPACTED TO 95%.
- REFERENCE SHEAR DIAGRAM FOR ANCHOR BOLT SPACING.
- FOLLOW MANUFACTURER'S RECOMMENDATIONS WHEN INSTALLING JOISTS.
- DON'T RECOMMEND, MANDATORY CONSTRUCTION ADHESIVE BE USED AT ALL FLOOR CONNECTIONS INCLUDING FLOOR SHEETING TO JOIST, IN JOIST HANGERS, JOIST HANGER PLATES, JOIST TO PONY WALL CONNECTIONS, AND BLOCKING CONNECTIONS.
- IF FLOOR SHEETING GETS WET DURING CONSTRUCTION, RECOMMENDED THE NAILS GET RE-SET WITH A BALL-PEEN HAMMER.

**ENGINEERING NOTES:**

- COLUMN, CONNECTION AND BEAM SIZING ARE MINIMUMS. UPGRADED SIZE OR QUALITY IS ACCEPTABLE.
- ALTERNATIVE MATERIALS OR SIZES MAY BE FOUND IN THE ENGINEERING CALCULATIONS IF NOT NOTED ON THE DRAWING.
- UNLESS OTHERWISE NOTED MINIMUM BEAM SUPPORT OR TRIMMER IS A 2x6 DF#2 OR 2x4 DF#2.
- UNLESS OTHERWISE NOTED EXTERIOR FOOTING OR STRIP FOOTING MEETS MINIMUM LOAD REQUIREMENTS.
- IF CONNECTION IS UNSPECIFIED USE NAILED FRAMING CONNECTION.
- BOLTED CONNECTION OR SIMPSON PC POST CAP.

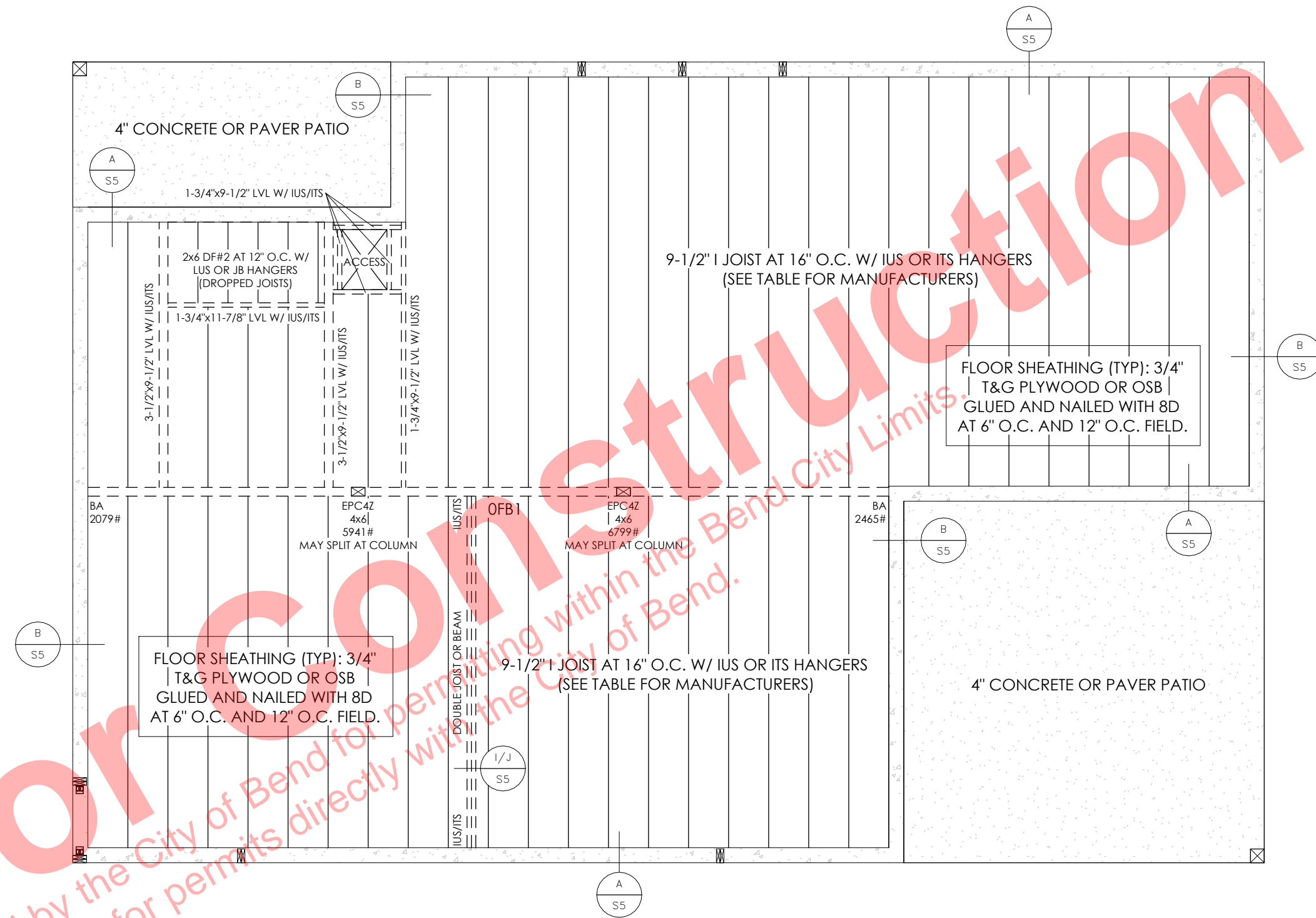

**SUBFLOOR FRAMING**

1/4" = 1'-0"

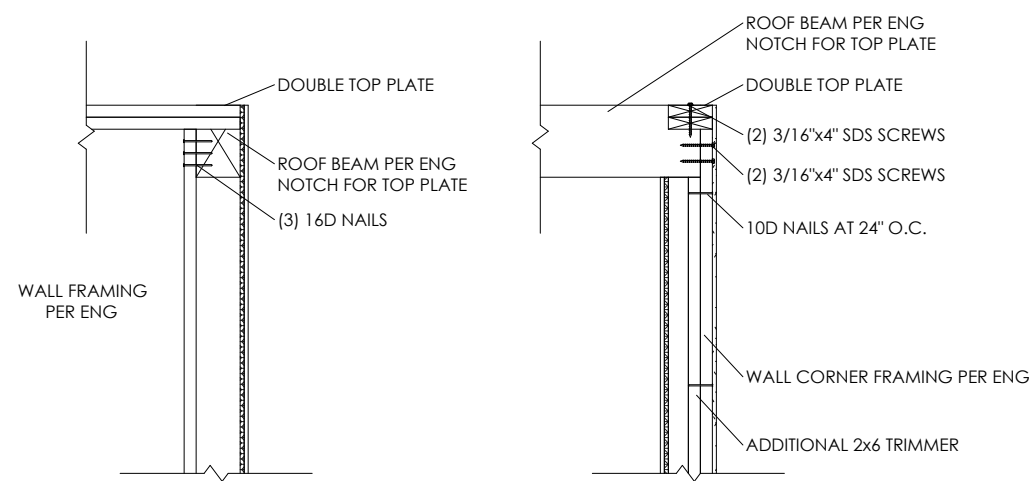

**DEVIATION STATEMENT**  
 ANY DEVIATION FROM ARCHITECTURAL OR STRUCTURAL  
 PLAN REQUIRES REVIEW BY LICENSED ENGINEER.



**(A) BEAM WALL POCKET**  
 1/2" = 1'-0"

WIND SPEED, EXPOSURE, SNOW LOAD AND SDS  
 MAY NOT BE EXCEEDED. CONTACT ENGINEER FOR  
 REDESIGN IF LOCATION EXCEEDS THESE VALUES.

**VARIABLE TABLE**

VARIABLE	VALUE	CODE REFERENCE
WIND SPEED	99 MPH, EXP C	[IBC-ASCE7-16]
GROUND SNOW LOAD	50 PSF	[SEAO-ASCE7-16]
SEISMIC	0.38g g	[ASCE7-16]
FROST DEPTH	18"	[ORSC R301.2]

PLAN EVALUATED: SJC "Deschutes Bungalow"

**FRAMING LEGEND**

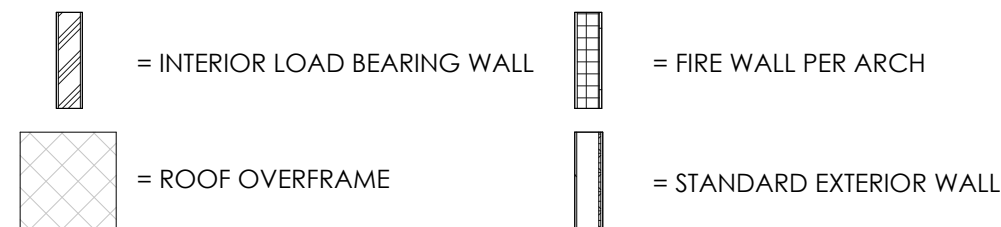

**1 LEVEL BEAMS**

MARK	LENGTH	SIZE & MATERIAL
1H1	7'	2-2x6 DF#2
1H2	7'	2-2x6 DF#2
1H3	3.5'	2x6 DF#2
1H4	5.5'	4x8 DF#2
1H5	3'	2x6 DF#2
1H6	3.5'	2x6 DF#2
1H7	14'	2-2x6 DF#2
1H8	3.5'	2x6 DF#2
1H9	5'	2x6 DF#2
1H10	7.5'	2-2x6 DF#2
1RB1	12.5'	5-1/2"x9" 24F-V4 DF GLB
1RB2	12.5'	5-1/2"x9" 24F-V4 DF GLB
1RB3	11'	5-1/2"x7-1/2" 24F-V4 DF GLB
1RB4	11'	5-1/2"x7-1/2" 24F-V4 DF GLB

**ROOF FRAMING NOTES**

- REFERENCE MANUFACTURED TRUSS ENGINEERING.
- REFERENCE ENGINEER'S GRAVITY LOADS ENGINEERING FOR BEAM ALTERNATIVES.
- PLYWOOD ROOF SHEATHING SHALL NOT EXCEED THE ALLOWABLE SPANS INDICATED BY THE PANEL ID.
- ATTIC SPACES HAVING 30" OR GREATER VERTICAL CLEAR HEIGHT ARE REQUIRED TO A MINIMUM OF 22" X30" ATTIC ACCESS.
- USE SIMPSON H1 OR H2.5A PLATE TIES ON ALL RAFTER AND TRUSS PLATE CONNECTIONS.
- RAFTER, CEILING JOISTS, AND TRUSSES SHALL BE SUPPORTED LATERALLY AT BEARING POINTS BY SOLID BLOCKING TO PREVENT ROTATION AND LATERAL DISPLACEMENT.
- THE ROOFING MATERIAL MUST BE AN APPROVED MATERIAL INSTALLED AS SPECIFIED BY THE MANUFACTURER.
- DIAPHRAGMS ROOF: 7/16" OSB OR 1/2" CDX PLYWOOD W/ 8D GALV AT 6" O.C. EDGE AND 6" O.C. FIELD
- USE ICE SHIELD 48" ABOVE WALL LINES AND 36" UP VALLEYS.
- 30# FELT UNDER STANDING SEAM METAL AND COMPOSITE ROOF.
- ATTIC VENTILATION: 15F VENT SPACE TO 150SF ATTIC SPACE.

**WALL FRAMING NOTES**

- ONE STORY WALLS TO BE MINIMUM 2x6 DF#2 OR STUD AT 24" O.C.
- TWO STORY WALLS TO BE MINIMUM 2x6 DF#2 OR STUD AT 16" O.C.
- INTERIOR LOAD BEARING WALLS TO BE MINIMUM 2x4 DF#2 AT 16" O.C.
- WALLS OVER 10' - 0" TALL TO REQUIRE SOLID MID PLANE BLOCKING AND 2x6 DF#2 OR LSL AT 16" O.C.
- WALLS MAY BE UPGRADED FOR PLUMBING, ELECTRIC, OR HVAC PER CONTRACTOR.

**ENGINEERING NOTES:**

- COLUMN, CONNECTION AND BEAM SIZING ARE MINIMUMS. UPGRADED SIZE OR QUALITY IS ACCEPTABLE.
- ALTERNATIVE MATERIALS OR SIZES MAY BE FOUND IN THE ENGINEERING CALCULATIONS IF NOT NOTED ON THE DRAWING.
- UNLESS OTHERWISE NOTED MINIMUM BEAM SUPPORT OR TRIMMER IS A 2x6 DF#2 OR 2x4 DF#2.
- UNLESS OTHERWISE NOTED EXTERIOR FOOTING OR STRIP FOOTING MEETS MINIMUM LOAD REQUIREMENTS.
- IF CONNECTION IS UNSPECIFIED USE NAILED FRAMING CONNECTION.
- BOLTED CONNECTION OR SIMPSON PC POST CAP.

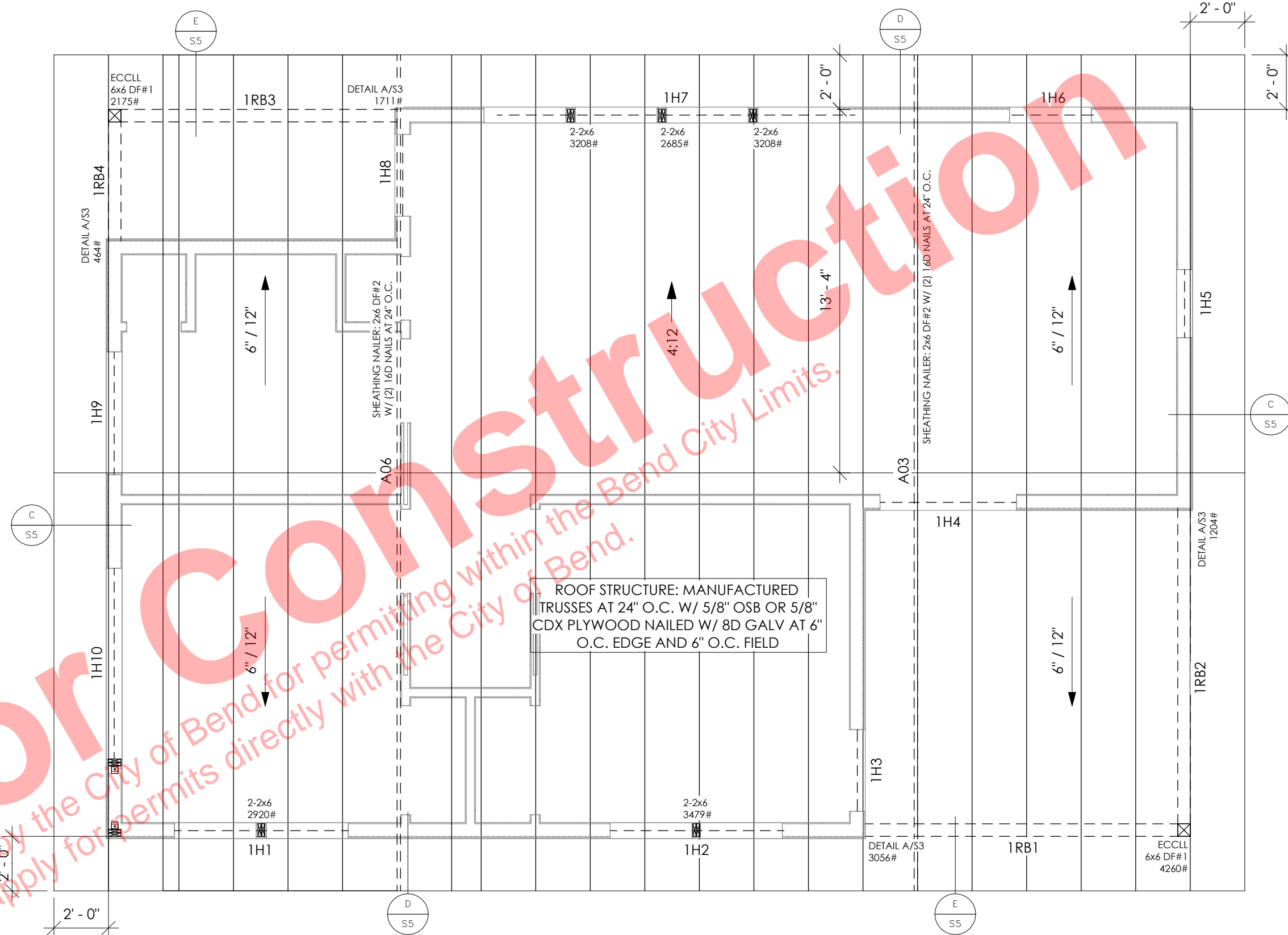

**MAIN LEVEL FRAMING**

1/4" = 1'-0"

**Garrett J. Banton, PE**  
 3008 NE Charleston Ct.  
 Bend, OR 97701  
 Phone: (541) 306-7893  
 team@bantoneengineering.com



DESCHUTES BUNGALOW  
 CITY OF BEND LIMITS

MAIN LEVEL  
 FRAMING

FILE:  
 SCALE: As indicated  
 DATE: 3/6/26

S3

**DEVIATION STATEMENT**  
 ANY DEVIATION FROM ARCHITECTURAL OR STRUCTURAL  
 PLAN REQUIRES REVIEW BY LICENSED ENGINEER.

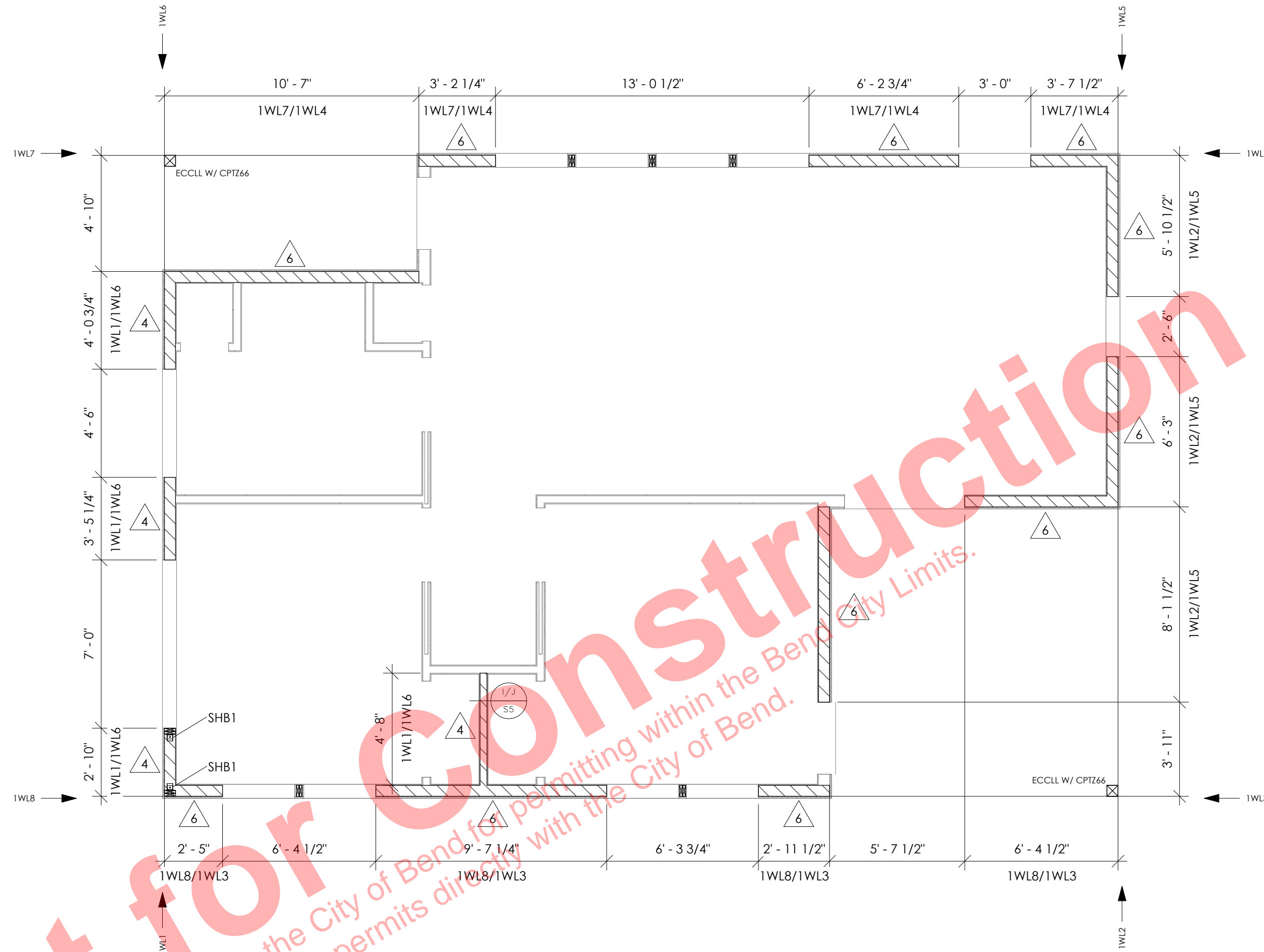

## MAIN LEVEL LATERAL

1/4" = 1'-0"

WIND SPEED, EXPOSURE, SNOW LOAD AND SDS  
 MAY NOT BE EXCEEDED. CONTACT ENGINEER FOR  
 REDESIGN IF LOCATION EXCEEDS THESE VALUES.

### VARIABLE TABLE

VARIABLE	VALUE	CODE REFERENCE
WIND SPEED	99 MPH, EXP C	[IBC-ASCE7-16]
GROUND SNOW LOAD	50 PSF	[SEAO-ASCE7-16]
SEISMIC	0.38g	[ASCE7-16]
FROST DEPTH	18"	[ORSC R301.2]

PLAN EVALUATED: SJC "Deschutes Bungalow"

## SHEAR WALL SCHEDULE

WARNING: IT IS THE RESPONSIBILITY OF THE USER OF THIS DOCUMENT TO ENSURE THAT ALL THE TECHNICAL INFORMATION IS PROPERLY IMPLEMENTED DURING CONSTRUCTION OF THE STRUCTURE. FAILURE TO INCORPORATE ALL OF THE REQUIREMENTS OF THIS DESIGN MAY INVALIDATE THE LATERAL INTEGRITY OF THE STRUCTURE AND RELEASE RESPONSIBILITY FROM THE ENGINEER OF RECORD.

No.	SHEAR WALL	SILL FASTENER	CONCRETE ANCHOR BOLTS
6	7/16" OSB OR 1/2" CDX W/8D AT 6" O.C. EDGE/12" O.C. FIELD SHEAR VALUES: [240 PLF24][260 PLF16][170 PLF Staple][223 PLF HF][242 PLF HF]	2x SOLE PLATE TO JOIST, DECK, BLOCKING W/16D AT 6" O.C. (TOP)/8D AT 6" O.C. (EDGE)	5/8" x 10" J BOLTS AT 48" O.C. 1/2" x 10" J BOLTS AT 48" O.C.
4	7/16" OSB OR 1/2" CDX W/8D AT 4" O.C. EDGE/12" O.C. FIELD SHEAR VALUES: [350 PLF24][380 PLF16][260 PLF Staple][326 PLF HF][354 PLF HF]	2x SOLE PLATE TO JOIST, DECK, BLOCKING W/16D AT 4" O.C. (TOP)/8D AT 4" O.C. (EDGE)	5/8" x 10" J BOLTS AT 40" O.C. 1/2" x 10" J BOLTS AT 24" O.C.
3	7/16" OSB OR 1/2" CDX W/8D AT 3" O.C. EDGE/12" O.C. FIELD SHEAR VALUES: [450 PLF24][490 PLF16][345 PLF Staple][418 PLF HF][456 PLF HF]	2x SOLE PLATE TO JOIST, DECK, BLOCKING W/16D AT 4" O.C. (TOP)/8D AT 3" O.C. (EDGE)	5/8" x 10" J BOLTS AT 30" O.C. 1/2" x 10" J BOLTS AT 20" O.C.
2	7/16" OSB OR 1/2" CDX W/8D AT 2" O.C. EDGE/12" O.C. FIELD SHEAR VALUES: [585 PLF24][640 PLF16][440 PLF Staple][544 PLF HF][595 PLF HF]	4x SOLE PLATE TO JOIST, DECK, BLOCKING W/16D AT 4" O.C. (TOP)/8D AT 2" O.C. (EDGE) USE 2"x2" COMMERCIAL WASHERS	5/8" x 12" J BOLTS AT 24" O.C. 1/2" x 12" J BOLTS AT 16" O.C.
*	1/2" GYP W/5D x 1-5/8" COOLER OR #6/1.25" SCREW AT 7" O.C. EDGE/12" O.C. FIELD SHEAR VALUES: [100 PLF]	2x SOLE PLATE TO JOIST, DECK, BLOCKING W/16D AT 6" O.C. (TOP)/CEILING BLOCKING	1/2" x 10" J BOLTS AT 72" O.C.
C	RAKE AND PONY WALLS ABOVE STEM WALL TO USE WALL LINE BRACING REQUIREMENT. SOLID CONCRETE WALL LATERAL RESISTANCE EQUAL OR GREATER TO DESIGNATED WALL LINE REQUIREMENT. ENGINEER TO USE UPGRADED LATERAL RESISTANCE VALUES AT THEIR OWN DISCRETION.		

### SHEAR ANALYSIS

- MIN. ROOF DIAPHRAGM 7/16" OSB OR 1/2" CDX PLYWOOD W/ 8D GALV AT 6" O.C. EDGE AND 6" O.C. FIELD
- MINIMUM FLOOR DIAPHRAGM: 3/4" T&G OSB OR PLYWOOD GLUED AND NAILED W/10D RING SHANK AT 6" O.C. EDGE AND 12" O.C. FIELD, 4" CONCRETE.
- UNLESS SPECIFICALLY NOTED, ALL EXTERIOR WALLS SHALL BE SHEETED ONE SIDE WITH 7/16" OSB OR 1/2" STRUCT. PLYWOOD W/ MIN. NAIL SCHEDULE OF 8D GALV NAILS AT 6" O.C. EDGE AND 12" O.C. FIELD.
- SIMPSON H1 OR H2.5A HOLD DOWNS AT ALL RAFTER/TRUSS-PLATE CONNECTIONS.
- ANCHORS, HOLD DOWNS, STRAPS AS SHOWN.
- BLOCKING REQUIRED ON ALL EXTERIOR SHEETING HORIZONTAL JOINTS.
- ALL CREDITED INTERIOR SHEAR WALLS REQUIRE BLOCKING AT FLOOR PLATE AND CEILING.
- ALL SIMPSON HARDWARE INSTALLED PER GUIDELINES.
- J BOLTS CAN BE REPLACED WITH WEDGE ANCHORS OR TITENHD SCREWS OF THE SAME DIAMETER. MINIMUM LENGTH OF ANCHOR/SCREW TO BE 8" LONG.

### HOLD DOWN SCHEDULE

MARK	HOLD DOWN	ANCHOR	SCREW OPTION	EPOXY ANCHOR OPTION	COUNT
SHB1	HDUE3	SABR5/8X24	5/8" TITENHD W/ 4" EMBEDDMENT	5/8" ATR W/ 6" EMBEDDMENT	2

**Garrett J. Banton, PE**  
 3008 NE Charleston Ct.  
 Bend, OR 97701  
 Phone: (541) 306-7893  
 team@bantoneengineering.com



DESCHUTES BUNGALOW  
 CITY OF BEND LIMITS

MAIN LEVEL  
 LATERAL

FILE:  
 SCALE: 1/4" = 1'-0"  
 DATE: 3/6/26

S4

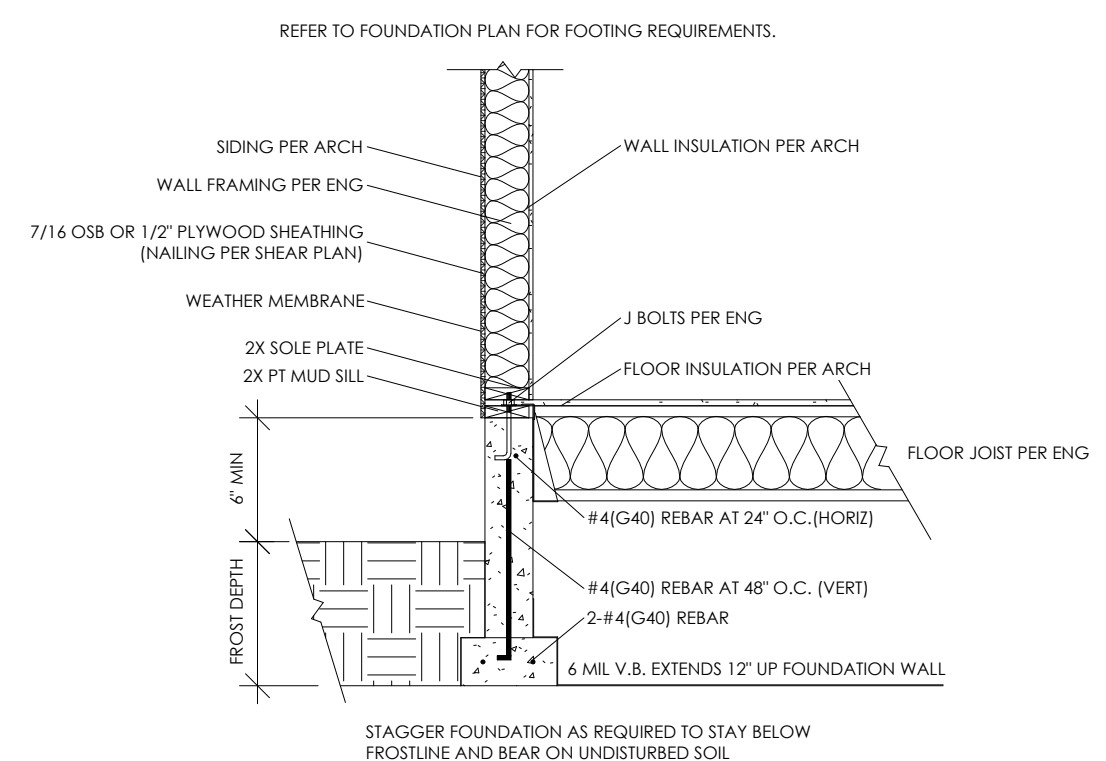

**A EXTERIOR FOUNDATION DETAIL**  
1/2" = 1'-0"

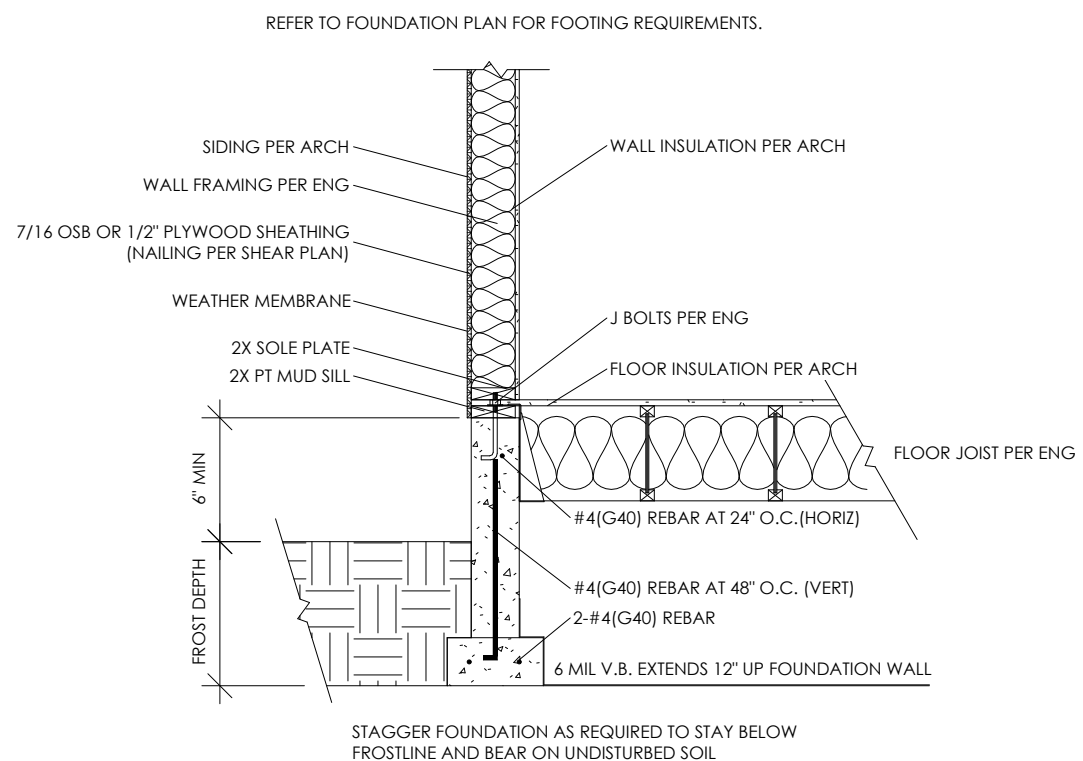

**B EXTERIOR FOUNDATION DETAIL (PERPENDICULAR)**  
1/2" = 1'-0"

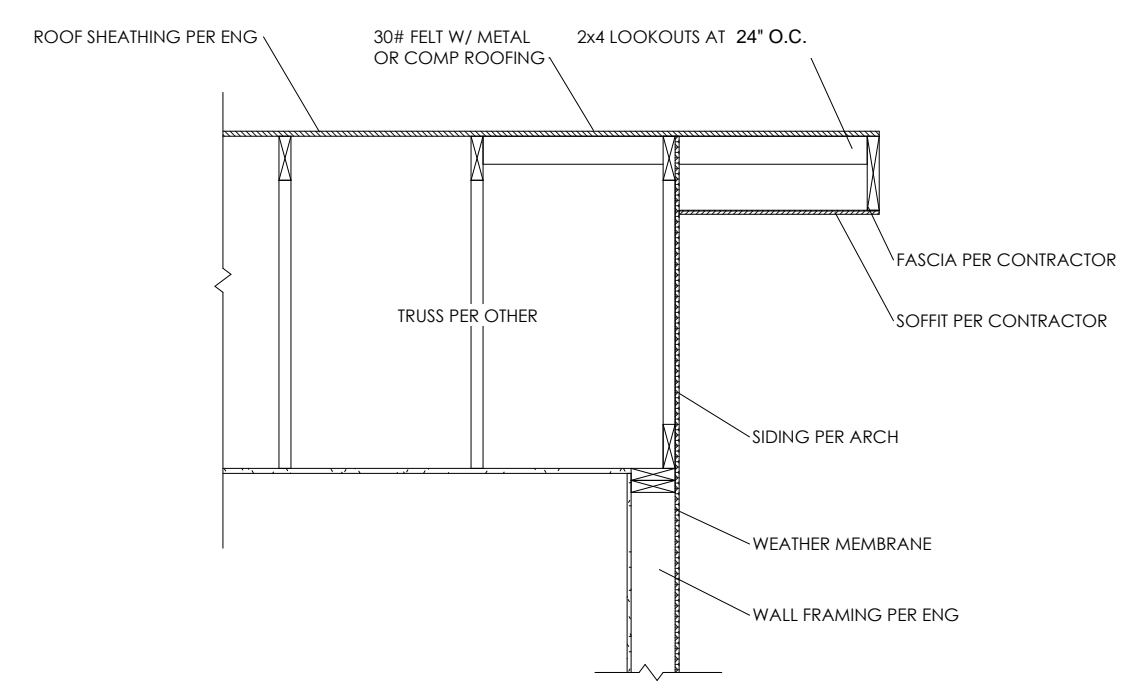

**C ROOF CONNECTION DETAIL (GABLE)**  
1/2" = 1'-0"

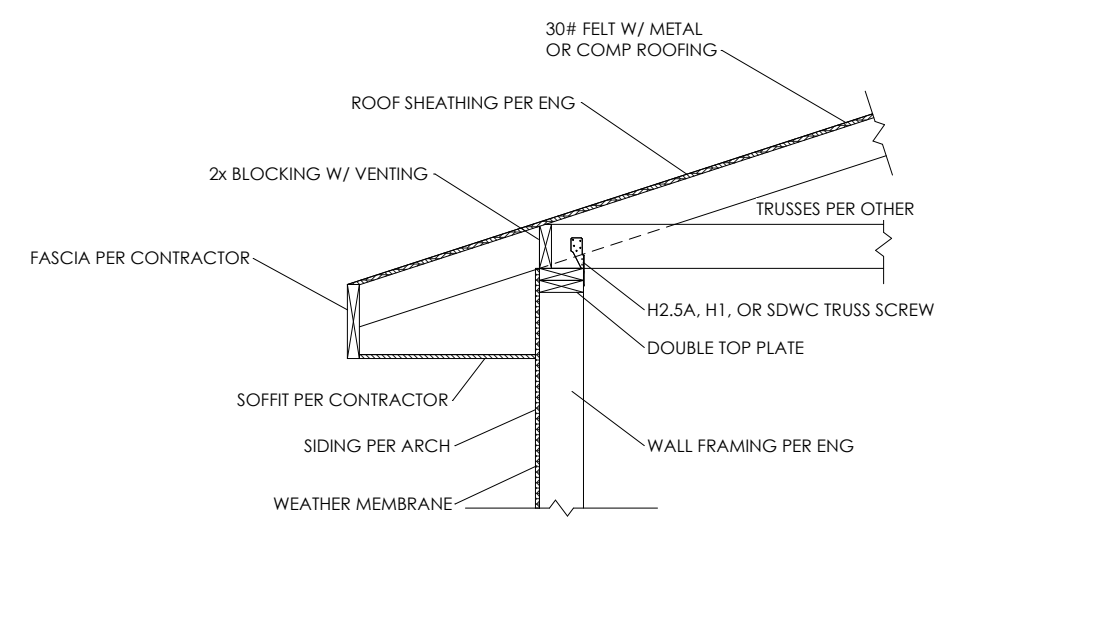

**D ROOF CONNECTION DETAIL (EVE)**  
1/2" = 1'-0"

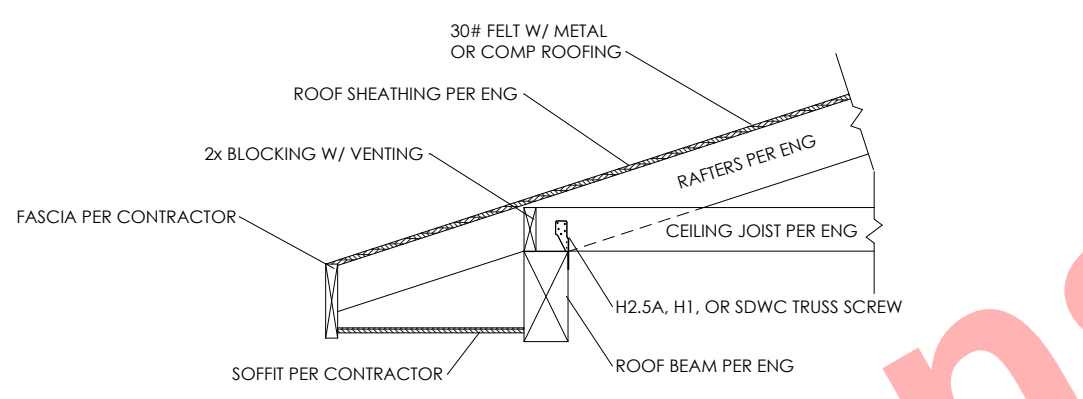

**E ROOF CONNECTION DETAIL (VAULTED BEAM)**  
1/2" = 1'-0"

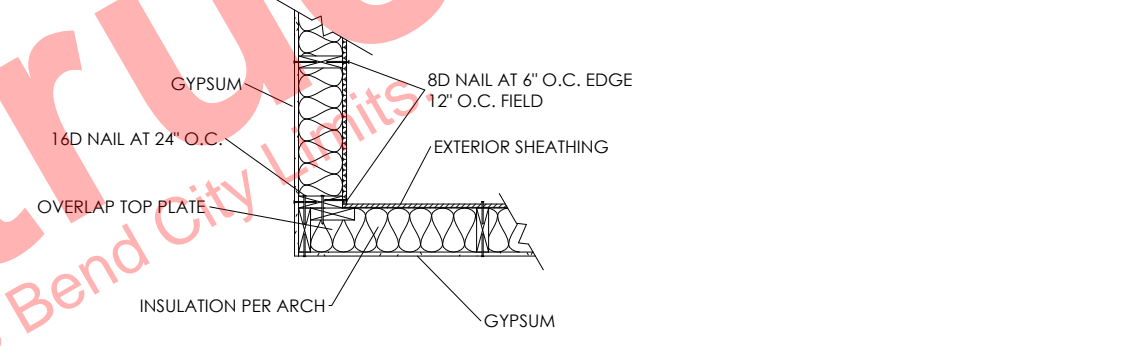

**F EXTERIOR WALL FRAME (INSIDE CORNER)**  
1/2" = 1'-0"

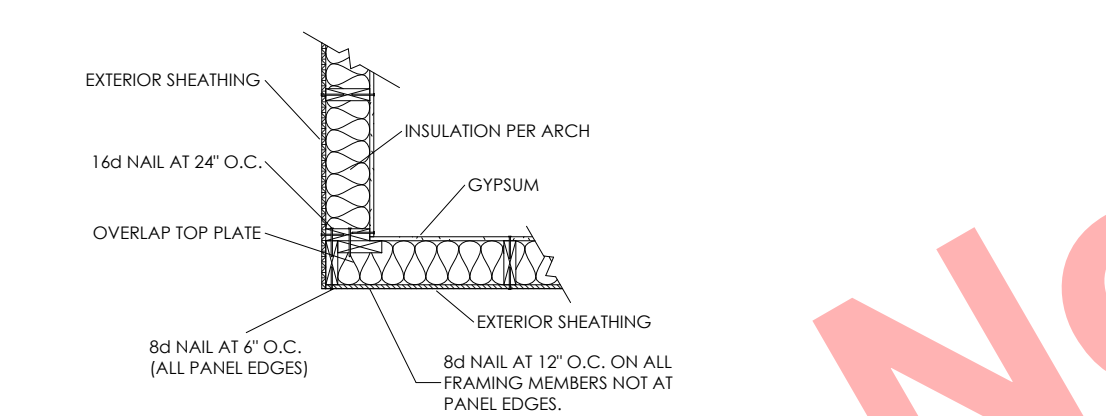

**G EXTERIOR WALL FRAME (OUTSIDE CORNER)**  
1/2" = 1'-0"

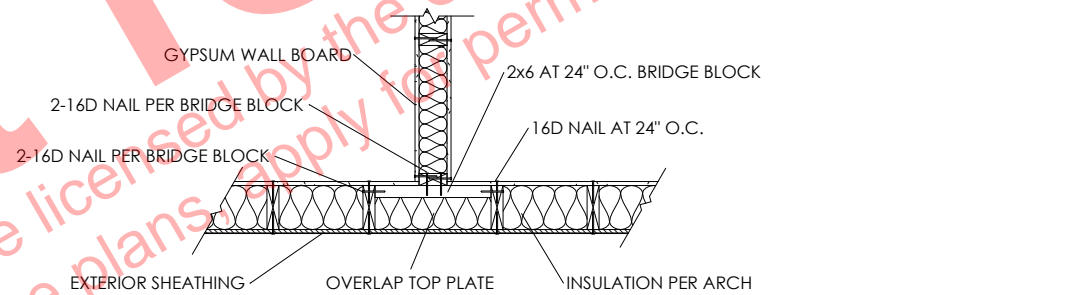

**H EXTERIOR WALL FRAME (WALL JOINT)**  
1/2" = 1'-0"

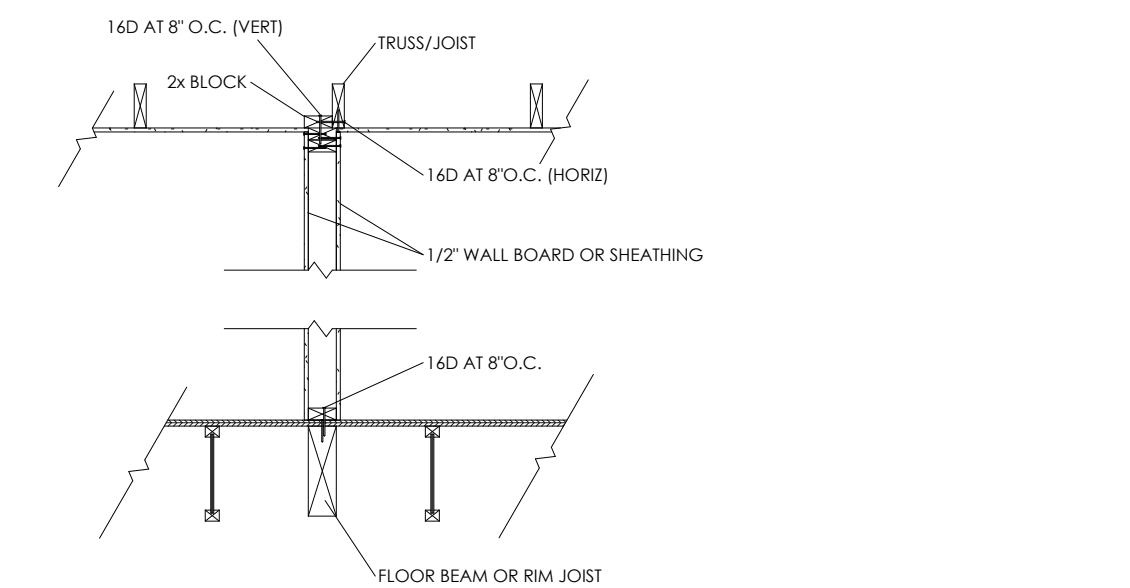

**I INTERIOR SHEAR WALL (FLOOR BEAM)**  
1/2" = 1'-0"

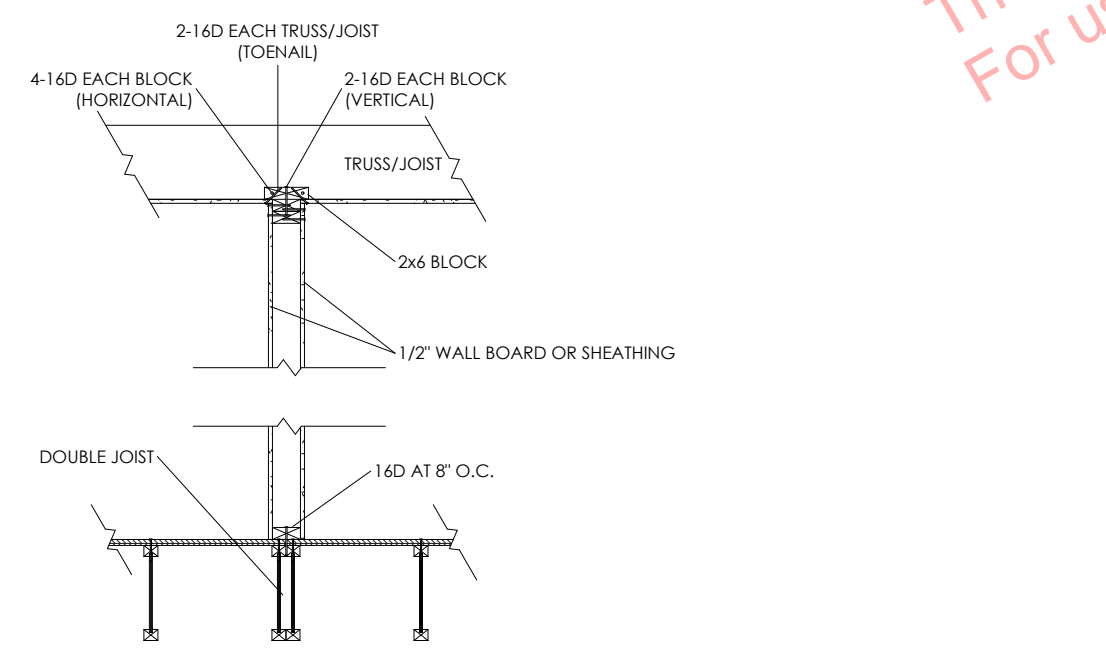

**J INTERIOR SHEAR WALL (TYP) (PARA JOIST OPT)**  
1/2" = 1'-0"

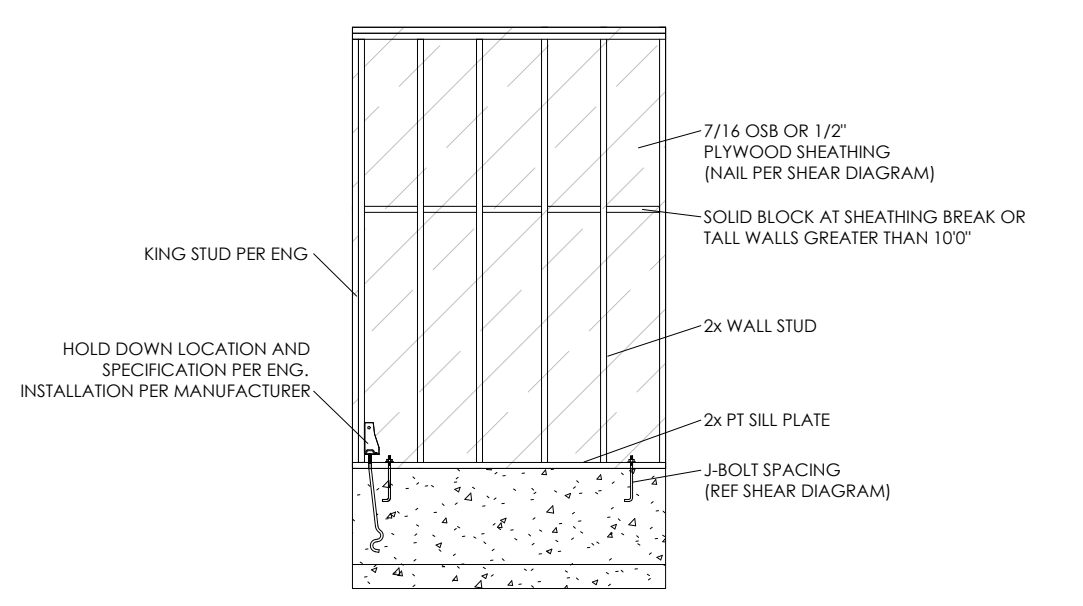

**K SHEAR WALL**  
1/4" = 1'-0"

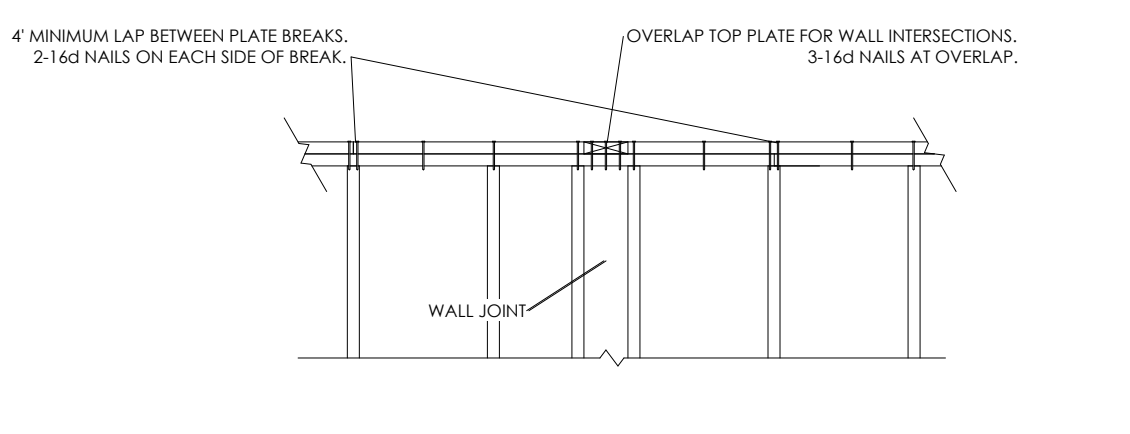

**L TOP PLATE FRAMING**  
1/2" = 1'-0"

Not for Construction  
 These plans are licensed by the City of Bend for permitting within the Bend City Limits  
 For use of these plans, apply for permits directly with the City of Bend

**Garrett J. Banton, PE**  
3008 NE Charleston Ct.  
Bend, OR 97701  
Phone: (541) 306-7893  
team@bantoneengineering.com



DESCHUTES BUNGALOW  
CITY OF BEND LIMITS

DETAILS

FILE:  
SCALE: As indicated  
DATE: 3/6/26



Building Safety Division  
City of Bend  
(541) 388-5580 ext. 3  
building@bendoregon.gov  
710 NW Wall Street, Bend OR 97703

This submittal form is to be completed as part of your application with the City of Bend. *Download this form before completing fillable fields*, then upload with your application through the Online Permit Center at [www.bendoregon.gov/permitcenter](http://www.bendoregon.gov/permitcenter).

## 2023 RESIDENTIAL CODE ENERGY, LIGHTING EFFICIENCY, MOISTURE CONTENT, AND WHOLE-HOUSE VENTILATION CHECKLIST

**Instructions:** Select the type of construction. If the project is an addition, select the applicable addition type and enter the selected measures accordingly.

**New Construction.** All conditioned spaces within residential buildings shall comply with Table N1101.1(1) and one additional measure from Table N1101.1(2). New buildings using N1105.3 Exception #3, shall select two additional measures from Table N1101.1(2).

**Additions.** Additions to existing buildings or structures may be made without making the entire building or structure comply if the new additions comply with the requirements of this chapter [see ORSC Section N1101.3].

**Large Additions.** Additions that are equal to or more than 600 square feet in area are required to select one measure from Table N1101.1(2).

Enter the selected Table N1101.1(2) additional measure: \_\_\_\_\_

**Small Additions.** Additions that are less than 600 square feet in area are required to select one measure from Table N1101.1(2) or Table N1101.3

Selected Table N1101.1(2) additional measure \_\_\_\_\_

Selected Table N1101.3 additional measure \_\_\_\_\_

**Exception:** Additions that are less than 225 square feet in area are not required to comply with Table N1101.1(2) or Table N1101.3.

*Note: Depending on the additional measure you have selected, there may be sub-options that you will have to specify. Check the appropriate box, if provided.*

Table N1101.1(2), Section N1101.3, Table 1104.8, Section N1104.8, and Section N1105.3 are included on the following pages (**Please check all applicable boxes**)

<b>TABLE N1101.1(2) – ADDITIONAL MEASURES</b>	
1	<input type="checkbox"/> <b>High efficiency HVAC system<sup>a</sup></b> <input type="checkbox"/> Gas-fired furnace or boiler AFUE 94 percent, or <input type="checkbox"/> Air-source heat pump HSPF 10.0/14.0 SEER cooling, 8.5 HSPF2/ 15.0 SEER2, or <input type="checkbox"/> Ground-source heat pump COP 3.5 or Energy Star rated
2	<input type="checkbox"/> <b>High-Efficiency Water Heating System</b> <input type="checkbox"/> Natural gas/propane water heater with minimum 0.90 EUF, or <input type="checkbox"/> Electric heat pump water heater with minimum 3.45 UEF, or <input type="checkbox"/> Natural gas/propane tankless/instantaneous heater with minimum 0.80 UEF and Drain Water Heat Recovery Unit installed on minimum of one shower/tub-shower
3	<input type="checkbox"/> <b>Wall Insulation Upgrade</b> Exterior walls – U-0.045/R-21 conventional framing with R-5.0 continuous insulation
4	<input type="checkbox"/> <b>Advanced Envelope</b> <ul style="list-style-type: none"> <li>• Windows – U-0.21 (Area weighted average), and</li> <li>• Flat ceiling<sup>b</sup> – U-0.017/R-60, and</li> <li>• Framed floors – <input type="checkbox"/> U-0.026/R-38 or <input type="checkbox"/> slab edge insulation to F-0.48 or less (R-10 for 48”; R-15 for 36” or R-5 fully insulated slab)</li> </ul>
5	<input checked="" type="checkbox"/> <b>Ductless Heat Pump</b> For dwelling units with all-electric heat, provide: <ul style="list-style-type: none"> <li>• Ductless heat pump of minimum HSPF 10 or HSPF2 9.0 in primary zone replaces zonal electric heat sources, and</li> <li>• Programmable thermostat for all heaters in bedrooms</li> </ul>
6	<input type="checkbox"/> <b>High efficiency thermal envelope UA<sup>c</sup></b> Purposed UA is 8 percent lower than the code UA
7	<input type="checkbox"/> <b>2.75 ACH Air Leakage Control and Efficient Ventilation</b> Achieve a maximum of 2.75 ACH50 whole-house air leakage when third-party tested and provide a whole-house ventilation system including heat recovery with a minimum sensible heat recovery efficiency of not less than 66 percent and total fan efficacy of 1.6 CFM/Watt (combined input for supply and exhaust).

For SI: 1 square foot=0.093m<sup>2</sup>, 1 watt per square foot=10.8 W/m<sup>2</sup>.

**Notes (superscripts)**

- a. Appliances located within the building thermal envelope shall have sealed combustion air installed. Combustion air shall be ducted directly from the outdoors.
- b. The maximum vaulted ceiling surface area shall not be greater than 50 percent of the total heated space floor area unless vaulted area has a U-factor no greater than U-0.026.
- c. In accordance with Table N1104.1(1), the Proposed UA total of the Proposed Alternative Design shall be a minimum of 8 percent less than the Code UA total of the Standard Base Case.

<b>TABLE N1101.3 SMALL ADDITION ADDITIONAL MEASURES (Select One)</b>		
1	<input type="checkbox"/>	Increase the ceiling insulation of the existing portion of the home as specified in Table N1101.2
2	<input type="checkbox"/>	Replace all existing single-pane wood or aluminum windows to the <i>U</i> -factor as specified in N1101.2
3	<input type="checkbox"/>	Insulate the existing floor, crawl space, or basement wall systems as specified in Table N1101.2 and install 100 percent of permanently installed lighting fixtures as CFL, LED or linear fluorescent, or a minimum efficacy of 40 lumens per watt as specified in section N1107.2
4	<input type="checkbox"/>	Test the entire dwelling with a blower door and exhibit no more than 4.5 air changes per hour at 50 Pascals
5	<input type="checkbox"/>	Seal and performance test the duct system
6	<input type="checkbox"/>	Replace existing 80-percent AFUE or less gas furnace with a 94-percent AFUE or greater system
7	<input type="checkbox"/>	Replace existing electric radiant space heaters with a ductless mini split system with a minimum HSPF of 10.0 or HSPF2 of 9.0
8	<input type="checkbox"/>	Replace existing electric forced air furnace with an air source heat pump with a minimum HSPF of 9.5 or HSPF2 of 8.1
9	<input type="checkbox"/>	Replace existing water heater with one of the following: A) Natural gas/propane water heater with minimum UEF 0.90, or B) Electrical heat pump water heater with minimum 3.45 UEF

**N1104.8 Air Leakage.** The building thermal envelope shall be constructed to limit air leakage in accordance with this section.

<b>TABLE N1104.8 AIR BARRIER INSTALLATION AND AIR SEALING REQUIREMENTS</b>	
General Requirements	A continuous air barrier shall be installed in alignment with the building thermal envelope.
	Breaks or joints in the air barrier shall be sealed.
Ceiling/Attic	The air barrier in any dropped ceiling or soffit shall be aligned with the insulation and any gaps in the air barrier shall be sealed.
	Access openings, drop-down stairs, or knee wall doors to unconditioned attic spaces shall be gasketed and sealed.
Walls	The junction of the foundation and sill plate shall be sealed.
	The junction of the top plate and the top of walls shall be sealed between wall cavities and windows or door frames
	All penetrations or utility services through the top and bottom plates shall be sealed.
	Knee walls shall be sealed.
Windows, skylights and doors	The space between framing and skylights, and the jambs of windows and doors shall be sealed.
Rim/band joists	Rim/band joists shall be a part of the thermal envelope and have a continuous air barrier.
Floors Including cantilevered floors and floors above garages	The air barrier shall be installed at any exposed edge of insulation
Crawl space walls	Exposed earth in unvented crawl spaces shall be covered with a Class I vapor retarder with overlapping joints taped.

Shafts, penetrations	Duct shafts, utility penetrations and flue shafts opening to exterior or unconditioned space shall be sealed.
Garage separation	Air sealing shall be provided between the garage and conditioned spaces.
Recessed lighting	Recessed light fixtures installed in the building thermal envelope shall be sealed to the finished surface.
Shower/tub on exterior walls	The air barrier installed at exterior walls adjacent to showers and tubs shall separate the wall from the shower or tub.
Electrical/phone box on exterior walls	The air barrier shall be installed behind electrical and communication boxes. Alternatively, air-sealed boxes shall be installed.
HVAC register boots	HVAC supply and return register boots that penetrate building thermal envelope shall be sealed to the subfloor, wall covering or ceiling penetrated by the boot.

## INSTALLATION OF DUCTS

**N1105.3 Installation of ducts and air handling equipment.** For new construction and additions, all new duct systems and air handling equipment and appliances shall be located fully within the building thermal envelope. Exceptions:

1. Ventilation intake ductwork and exhaust ductwork.
2. Up to 10ft of HVAC system ductwork.
3. Where two measures are selected for compliance from Table N1011.1(2) and HVAC supply and return ductwork is installed in accordance with either Section N1105.3.1, N1105.3.2 or N1105.3.3.

**N1105.3.1 Deeply buried duct in attic.** Ducts deeply buried in attic insulation shall be in accordance with all of the following when using Section N1105.3, Exception 3:

1. Insulation shall be installed to fill gaps and voids between the duct and the ceiling, and a minimum of R19 insulation shall be installed above the duct between the duct and unconditioned attic.
2. All ductwork in the attic shall be insulated to R-8.
3. Insulation depth marker flags shall be installed on the ducts every 10 feet (3048 mm) or as approved by the building official.

**Exception:** HVAC ductwork shall be permitted to be located outside of the building thermal envelope where the duct is insulated to a minimum of R-27 with a Class II or III vapor retarder.

**N1105.3.2 Ducts in unvented crawlspace.** Ducts located in unvented crawlspace shall be in accordance with all of the following when using Section N1105.3, Exception 3:

1. In addition to meeting Section R408.3, all seams of the vapor barrier shall overlap a minimum of 12 inches (305 mm) and be sealed with tape or other approved method.
2. All ductwork in the crawlspace shall be insulated to R-8.
3. The floor between the crawlspace and the dwelling shall be insulated with minimum R-30.

**N1105.3.3 Deeply buried duct in vented crawlspace.** Ducts deeply buried in crawlspace insulation shall be in accordance all of the following when using Section N1105.3, Exception 3:

1. Insulation shall be installed to fill gaps and voids between the duct and the floor above, and a minimum of R-19 insulation shall be installed below the duct and between the duct and unconditioned crawlspace.
2. All ductwork in the crawlspace shall be insulated to R-8.

**Exception:** HVAC ductwork shall be permitted to be located outside of the building thermal envelope where the duct is insulated to a minimum of R-27 with a Class II or III vapor retarder.

**To comply with this requirement (Please select all applicable boxes). If using either 3 or 5, select 2 additional measures from Table N101.1(2) on page 1 per N1105.3.**

- 1. Ducts will be installed in the conditioned space
- 2. No heating or cooling ducts are being installed
- 3. Ducts in unconditioned attic will have R-19 above and comply with requirements for deeply buried ducts per N1105.3.1
- 4. Under-floor space will be conditioned per N1105.3.2 and meet requirements of R408.3 by (choose 1):
  - Continuously Operated Mechanical Exhaust (Required C.F.M. \_\_\_\_\_) or
  - Conditioned Air Supply (Required C.F.M. \_\_\_\_\_)
- 5. Under-floor space will not be conditioned and ducts will have R-19 insulation installed below duct per N1105.3.3
- 6. Other method will be used for heating and cooling ducts not in conditioned space. Please specify:

## MECHANICAL WHOLE-HOUSE VENTILATION SYSTEM (WHV)(2 steps)

**1. M1505.4.3 Mechanical ventilation rate.** The whole-house mechanical ventilation system shall provide outdoor air at a continuous rate not less than that determined in accordance with: (Choose one)

Equation 15-1. Ventilation rate in cubic feet per minute =  $(0.01 \times \text{total square foot area of house}) + [7.5 \times (\text{number of bedrooms} + 1)]$  (Equation 15-1)( $0.01 \times \underline{\hspace{2cm}}$ ) +  $[7.5 \times (\underline{\hspace{2cm}})] = \underline{\hspace{2cm}}$  CFM

**OR**

Table M1505.4.3(1)

**Table M 1505.4.3(1)**

### CONTINUOUS WHOLE-HOUSE MECHANICAL VENTILATION SYSTEM AIRFLOW RATE REQUIREMENTS

DWELLING UNIT FLOOR AREA (sq ft)	NUMBER OF BEDROOMS				
	0 to 1	2 to 3	4 to 5	6 to 7	>7
	AIRFLOW in CFM				
<1,500	30	45	60	75	90
1,501-3,000	45	60	75	90	105
3,001-4,500	60	75	90	105	120
4,501-6,000	75	90	105	120	135
6,001-7,500	90	105	120	135	150
>7,500	105	120	135	150	165

For SI: square foot = 0.0929 m<sup>2</sup>, 1 cubic foot per minute = 0.0004719m<sup>3</sup>/s

Enter C.F.M. rate here: 45 CFM

**2. Section 1505.4.** Enter base C.F.M. rate from equation in M1505.4.3 -OR- Table M1505.4.3(1) here: 45 CFM

Enter intermittent run-time factor from Table M1505.4.3(2) (See next page) here: 1 and multiply it by the base C.F.M. rate to determine calculated C.F.M. rate. Enter calculated C.F.M. here: 45 CFM

**TABLE M1505.4.3(2)**  
**INTERMITTENT WHOLE-HOUSE MECHANICAL VENTILATION RATE FACTORS** <sup>a, b</sup>

<b>RUN-TIME PERCENTAGE IN EACH 4-HOUR SEGMENT</b>	25%	33%	50%	66%	75%	100%
Factor <sup>a</sup>	4	3	2	1.5	1.3	1.0

a. For ventilation system run time values between those given, the factors are permitted to be determined by interpolation.

b. Extrapolation beyond the table is prohibited.

- Using M1505.4.3 exception 1 for 30% reduction to required ventilation rate.  
(Required ventilation rate from above) x (0.70) = (Total reduced ventilation required)  
( \_\_\_\_\_ CFM ) x (0.70) = ( \_\_\_\_\_ CFM).

To use M1505.4.3 exception 1, both of the following must be met:

- a. A ducted system supplies ventilation air directly to each bedroom and to one or more of the following rooms: Living room, dining room, or kitchen
- b. The whole-house ventilation system is a balanced ventilation system.

## HIGH EFFICIENCY LIGHTING

**Section N1107.2.** All permanently installed lighting fixtures shall be high efficiency light sources.

Exception: Two permanently installed lighting fixtures are not required to be high-efficiency light sources when controlled by a dimmer or automatic control.

*To conform to the 2023 Oregon Residential Specialty Code (ORSC), Section N1107, I am notifying the Building Official that I am aware of the high-efficiency lighting requirement of ORSC Section N1107.2 and have taken steps to meet this code requirement.*

\_\_\_\_\_  
Printed Name

\_\_\_\_\_  
Signature

\_\_\_\_\_  
Date

## MOISTURE CONTENT

**Section R318.2 Moisture Content.** Prior to the installation of interior finishes, the building official shall be notified in writing by the general contractor that all moisture-sensitive wood framing members used in construction have a moisture content of not more than 19 percent of the weight of dry wood framing members.

*To conform to the 2023 Oregon Residential Specialty Code (ORSC), Section R318.2, I am notifying the Building Official that I am aware of the moisture content requirement of ORSC Section R318.2 and have taken steps to meet this code requirement.*

\_\_\_\_\_  
Printed Name

\_\_\_\_\_  
Signature

\_\_\_\_\_  
Date



**Accommodation Information for People with Disabilities**

To obtain this information in an alternate format such as Braille, large print, electronic formats, etc., please contact the Building Safety Division at [building@bendoregon.gov](mailto:building@bendoregon.gov) or 541-388-5580 extension 2. Relay Users Dial 7-1-1.

# MXZ-2D20NLHZ

## 20,000 BTU/H HYPER HEAT PUMP OUTDOOR UNIT



Job Name:

System Reference:

Date:



### GENERAL FEATURES

- Built-in base pan heater
- Compressor overcurrent detection
- Compressor thermal protection
- Fan motor overheating/voltage protection
- High pressure protection
- Hyper-Heating INVERTER®: Hyper-heating performance offers 100% heating capacity at 5°F and 75% heating capacity at -13°F
- INVERTER-driven compressor: An inverter-driven compressor generates the precise capacity needed to maintain a temperature set point.
- Quiet operation: Outdoor units are as quiet as a typical conversation, and most indoor units are whisper quiet.
- Seacoast protection: Seacoast protection on heat exchanger and base panel (rated for 2,000 hrs. in accordance with ASTM B117 testing)
- Thermal Differential 1°F

Specifications			System
Unit Type			MXZ-2D20NLHZ
Cooling at 95F <sup>1</sup> (Non-Ducted // Mixed // Ducted)	Maximum Capacity	Btu/h	20,000 // 20,000 // 20,000
	Rated Capacity	Btu/h	18,000 // 19,000 // 20,000
	Minimum Capacity	Btu/h	11,600 // 13,800 // 16,000
	Maximum Power Input	W	2,680 // 2,340 // 2,000
	Rated Power Input	W	1,333 // 1,568 // 1,802
	Power Factor (208V)	%	0.99 // 0.99 // 0.99
	Power Factor (230V)	%	0.99 // 0.99 // 0.99
Heating at 47F <sup>2</sup> (Non-Ducted // Mixed // Ducted)	Maximum Capacity	Btu/h	25,500 // 25,500 // 25,500
	Rated Capacity	Btu/h	22,000 // 22,000 // 22,000
	Minimum Capacity	Btu/h	11,400 // 13,850 // 16,300
	Maximum Power Input	W	2,400 // 2,520 // 2,640
	Rated Power Input	W	1,612 // 1,650 // 1,688
	Power Factor (208V)	%	0.99 // 0.99 // 0.99
Heating at 17F <sup>3</sup> (Non-Ducted // Mixed // Ducted)	Maximum Capacity	Btu/h	22,000 // 22,000 // 22,000
	Rated Capacity	Btu/h	14,300 // 13,400 // 12,500
	Maximum Power Input	W	3,300 // 3,325 // 3,350
	Rated Power Input	W	1,518 // 1,501 // 1,510
	Maximum Capacity	Btu/h	22,000 // 22,000 // 22,000
Heating at 5F <sup>4</sup> (Non-Ducted // Mixed // Ducted)	Maximum Power Input	W	3,220 // 3,256 // 3,256
	Maximum Capacity	Btu/h	19,200 // 19,200 // 19,200
Heating at -13F <sup>5</sup> (Non-Ducted // Mixed // Ducted)	Maximum Power Input	W	2,622 // 2,622 // 2,622
	SEER <sup>2</sup>		19.30 // 16.80 // 14.30
Efficiency (Non-Ducted // Mixed // Ducted)	EER <sup>2</sup>		13.50 // 12.30 // 11.10
	HSPF <sup>2</sup> (IV) <sup>2</sup>		10 // 8.95 // 7.90
	COP at 47F <sup>2</sup>		4.00 // 3.90 // 3.82
	COP at 17°F at Maximum Capacity <sup>3</sup>		1.94 // 1.92 // 1.92
	COP at 5°F at Maximum Capacity <sup>4</sup>		2 // 1.98 // 1.98
	ENERGY STAR® Certified		Yes // Yes // Yes
	Electrical	Electrical Power Requirements	V AC / V AC, ø, Hz
Guaranteed Voltage Range		V AC	198 - 253
Voltage: Indoor - Outdoor, S1-S2		V AC	208/230
Voltage: Indoor - Outdoor, S2-S3		V DC	24
Recommended Wire Size (Indoor - Outdoor)		AWG	14
Short-circuit Current Rating (SCCR)		kA	5
MCA		A	21.7
MOCP		A	38

#### NOTES

<sup>1</sup>Cooling at 95°F (Indoor: 80°F DB, 67°F WB // Outdoor: 95°F DB, 75°F WB)

<sup>2</sup>Heating at 47°F (Indoor: 70°F DB, 60°F WB // Outdoor: 47°F DB, 43°F WB)

<sup>3</sup>Heating at 17°F (Indoor: 70°F DB, 60°F WB // Outdoor: 17°F DB, 15°F WB)

<sup>4</sup>Heating at 5°F (Indoor: 70°F DB, 60°F WB // Outdoor: 5°F DB, 4°F WB)

<sup>5</sup>Heating at -13°F (Indoor: 70°F DB, 60°F WB // Outdoor: -13°F DB, -14°F WB)

Capacity varies based on the number of indoor units operating and the model of the Multi-zone Outdoor Unit. For reference to connected capacity charts, please refer to Multi-zone Outdoor Unit Operational Performance.

For actual capacity performance based on indoor unit type and number of indoor units connected, please refer to MXZ Operational Performance.

Although the maximum connectable capacity is 130%, the outdoor unit cannot provide more than 100% of the rated capacity.

Please utilize this over capacity capability for load shedding or applications where it is known that all connected units will NOT be operating at the same time.

<sup>1</sup> Indoor/Outdoor Unit Operating Temperature Range (Cooling Air Temp [Maximum / Minimum]):

• Applications should be restricted to comfort cooling only; equipment cooling applications are not recommended for low ambient temperature conditions.

\*\* Outdoor Unit Operating Temperature Range (Cooling Thermal Lock-out / Re-start Temperatures; Heating Thermal Lock-out / Re-start Temperatures):

• System cuts out in heating mode and automatically restarts at these temperatures.

# SPECIFICATIONS: MXZ-2D20NLHZ

Specifications			System
Unit Type			MXZ-2D20NLHZ
Outdoor Unit	Fan Motor Full Load Amperage	A	1.74
	Fan Motor Output	W	88
	Defrost Method		Reverse Cycle
	Blue Fin Heat Exchanger Coating		Yes
	Airflow Rate Cooling/Heating	CFM	2,119 / 2,228
	Sound Pressure Level, Cooling <sup>1</sup>	dB (A)	51
	Sound Pressure Level, Heating <sup>2</sup>	dB (A)	53
	Compressor Type		Twin Rotary
	Compressor Model		SRB220FQYMC-L
	Compressor Oil Type // Charge	Type // oz	RM68EH // 20.3
	External Finish Color		Munsell 3.0Y 7.8/1.1
	Base Pan Heater		Built-in
	Unit Dimensions (W x D x H)	inch x inch x inch [mm x mm x mm]	37-11/32 x 13 x 31-11/32 [950 x 330 x 796]
	Package Dimensions (W x D x H)	inch x inch x inch [mm x mm x mm]	41-11/32 x 17-5/16 x 38-31/32 [1,050 x 440 x 990]
Unit Weight	lbs [kg]	137 [62]	
Package Weight	lbs [kg]	163 [74]	
ODU Operating Temp. Range	Cooling Intake Air Temp (Maximum / Minimum <sup>3</sup> )	°FDB	115 / 14
	Cooling Thermal Lock-out / Re-start Temperatures	°FDB	10 / 14
	Heating Intake Air Temp [Maximum / Minimum]	°FDB, °FWB / °FDB, °FWB	75, 65 / -12, -13
	Heating Thermal Lock-out / Re-start Temperatures**	°FDB	-22.5 / -14
Refrigerant	Type		R454B
	Pre-Charged Refrigerant Amount	lbs, oz	5, 5
	Maximum Pre-Charged Piping Length	ft	164
IDU Connection	Minimum Number of Connected IDU		2
	Maximum Number of Connected IDU		2
	Minimum Connected Capacity	Btu/h	12,000
	Maximum connected capacity	Btu/h	24,000
Piping	Liquid Pipe Size O.D. (Flared)	inch	A: 1/4 B: 1/4
	Gas Pipe Size O.D. (Flared)	inch	A: 3/8 B: 3/8
	Total Piping Length	ft [m]	164 [50]
	Farthest Piping Length	ft [m]	82 [25]
	Maximum Height Difference <sup>4</sup> , ODU above IDU	ft [m]	49 [15]
	Maximum Height Difference <sup>4</sup> , ODU below IDU	ft [m]	49 [15]
	Maximum Number of Bends for IDU		50

**NOTES**

<sup>1</sup>Cooling at 95°F (Indoor: 80°F DB, 67°F WB // Outdoor: 95°F DB, 75°F WB)

<sup>2</sup>Heating at 47°F (Indoor: 70°F DB, 60°F WB // Outdoor: 47°F DB, 43°F WB)

<sup>3</sup>Heating at 17°F (Indoor: 70°F DB, 60°F WB // Outdoor: 17°F DB, 15°F WB)

<sup>4</sup>Heating at 5°F (Indoor: 70°F DB, 60°F WB // Outdoor: 5°F DB, 4°F WB)

<sup>5</sup>Heating at -13°F (Indoor: 70°F DB, 60°F WB // Outdoor: -13°F DB, -14°F WB)

Capacity varies based on the number of indoor units operating and the model of the Multi-zone Outdoor Unit. For reference to connected capacity charts, please refer to Multi-zone Outdoor Unit Operational Performance.

For actual capacity performance based on indoor unit type and number of indoor units connected, please refer to MXZ Operational Performance.

Although the maximum connectable capacity is 130%, the outdoor unit cannot provide more than 100% of the rated capacity.

Please utilize this over capacity capability for load shedding or applications where it is known that all connected units will NOT be operating at the same time.

<sup>6</sup> Indoor/Outdoor Unit Operating Temperature Range (Cooling Air Temp [Maximum / Minimum]):

- Applications should be restricted to comfort cooling only; equipment cooling applications are not recommended for low ambient temperature conditions.

- Outdoor Unit Operating Temperature Range (Cooling Thermal Lock-out / Re-start Temperatures; Heating Thermal Lock-out / Re-start Temperatures):

- System cuts out in heating mode and automatically restarts at these temperatures.

## OUTDOOR UNIT ACCESSORIES: MXZ-2D20NLHZ

Stand	18 Single Fan Stand	QSMS1801M
	24 Single Fan Stand	QSMS2401M
	Condenser Wall Bracket - Stainless Steel Finish	QSWBSS
	Condenser Wall Bracket	QSWB2000M-1
	Outdoor Unit 3-14 inch Mounting Base Pair - Plastic	DSD-400P
	Outdoor Unit Stand 12 High	QSMS1201M
Port Adaptor	Adaptor 1/2 x 3/8	PAC-SK88RJ-E
	Adaptor 1/2 x 5/8	PAC-SK89RJ-E
	Adaptor 1/4 x 3/8	PAC-493PI
	Adaptor 3/8 x 1/2	ADP3812
	Adaptor 3/8 x 5/8	PAC-SK90RJ-E
Mini-Split Wire	14 Gauge 4 wire Armored MiniSplit Cable250 ft roll	SW144-250
	14 Gauge 4 wire Armored MiniSplit Cable50 ft roll	SW144-50
	14 Gauge 4 wire MiniSplit Cable250 ft roll	S144-250
	14 Gauge 4 wire MiniSplit Cable50 ft roll	S144-50
	16 Gauge 4 wire Armored MiniSplit Cable250 ft roll	SW164-250
	16 Gauge 4 wire Armored MiniSplit Cable50 ft roll	SW164-50
	16 Gauge 4 wire MiniSplit Cable250 ft roll	S164-250
	16 Gauge 4 wire MiniSplit Cable50 ft roll	S164-50
Air Outlet Guide	Air Outlet Guide 1 Piece	PAC-SH96SG-E (two pieces are required)
Drain Socket	Drain Socket	PAC-SG60DS-E
Ball Valve	Refrigeration Ball Valve - 1/2	BV12FFSI2
	Refrigeration Ball Valve - 1/4	BV14FFSI2
	Refrigeration Ball Valve - 3/8	BV38FFSI2
	Refrigeration Ball Valve - 5/8	BV58FFSI2
Mounting Pad	Condensing Unit Mounting Pad 16 x 36 x 3	ULTRILITE1
Control Interface	M-NET Interface for MXZ	PAC-IF01MNT-E
Hail Guards	Hail Guard	HG-A9
Snow/Rain Diverter	SnowRain Diverter	SRD-4
Control/Service Tool	Maintenance Tool Interface	PAC-USCMS-MN-1
NOTES		

# OUTDOOR UNIT DIMENSIONS: MXZ-2D20NLHZ

## MXZ-2D20NLHZ-U1

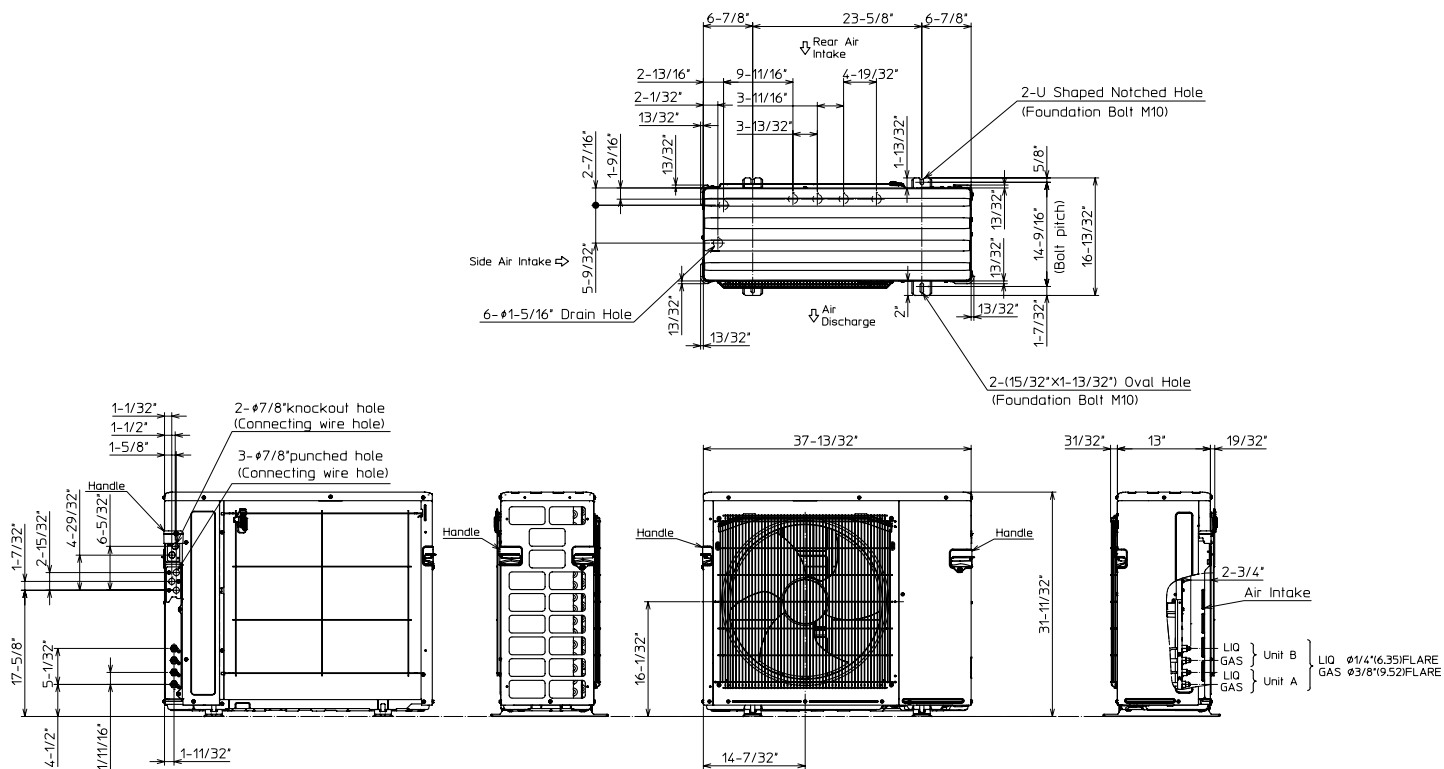

### 1.FREE SPACE

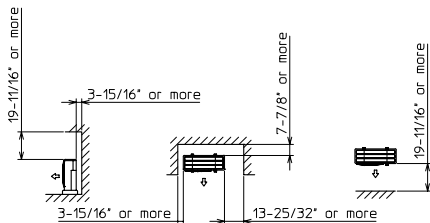

### 2.SERVICE SPACE

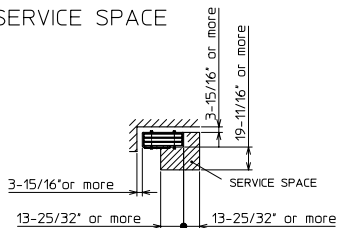

1340 Satellite Boulevard Suwanee, GA 30024  
Toll Free: 800-433-4822 <https://mitsubishicomfort.com>



METUS\_2025-05\_PROPIN



Building Safety Division  
City of Bend  
(541) 388-5580  
building@bendoregon.gov  
710 NW Wall Street, Bend OR 97703

This submittal form is to be completed as part of your application with the City of Bend. *Download this form before completing fillable fields*, then upload with your application through the Online Permit Center at [www.bendoregon.gov/permitcenter](http://www.bendoregon.gov/permitcenter).

## RESIDENTIAL MINI-SPLIT WORKSHEET

Oregon Building Codes Division requires that an additional heat source is available when installing mini-split or other heating/cooling absorption unit (heat pump) in Central Oregon; a mini-split system cannot be the sole source of heat for an entire home.

Please indicate the additional heat source for an entire home.

- Electric Wall Heater (i.e. Cadet heater)
- Furnace
- Radiant heat provided throughout residence
- Electric baseboard provided throughout residence
- Hydronic heat provided throughout residence
- \* Other: Mini-split as primary heat source

\* Mini-split as the sole heat source: A heat calculation showing the heat load at design conditions and the manufacturer's performance data must be provided for the unit showing heating output of 68°F in conditions of 5°F.

\* Application to be reviewed by Plans Examiner

Every dwelling unit shall be provided with heating facilities capable of maintaining a minimum room temperature of 68°F at a point 3 feet above the floor and 2 feet from exterior walls in all habitable rooms at the design temperature of 5°F.

The following uses are prohibited within all yard setbacks per [Bend Development Code 2.1.300.F.7](#): satellite dishes greater than 18 inches in diameter, heat pumps and other similar objects, unless screened for visual and noise abatement by a solid enclosure 2 feet higher than the object/use being screened. In no instance shall these uses be allowed within the front yard setbacks.

°=degrees F=Fahrenheit



### Accommodation Information for People with Disabilities

To obtain this information in an alternate format such as Braille, large print, electronic formats, etc. please contact the Building Safety Division at [building@bendoregon.gov](mailto:building@bendoregon.gov) or (541) 388-5580; Relay Users Dial 7-1-1.

## 2023 Oregon Residential Specialty Code Amendments

**Summary:** In accordance with Senate Bill 83 (2025) this amendment makes Section R327, *Wildfire Hazard Mitigation*, available for local adoption and applicable to new construction of new ORSC governed buildings.

This code amendment was adopted by temporary rule effective Aug. 5, 2025 through Jan. 2, 2026 and subsequently adopted by permanent rule effective Jan. 1, 2026.

The following amendments are adopted as part of the 2023 Oregon Residential Specialty Code (ORSC).

The changes are denoted as follows:

**Blue/underline** = Added code language  
**Red/del/through** = Deleted code language

### SECTION R302—FIRE-RESISTANT CONSTRUCTION

**R302.2.12 Townhouse roof coverings.** In addition to the requirements of Chapter 9, structurally independent townhouses shall be provided with a minimum Class C roof covering, and structurally dependent townhouses shall be provided with a minimum Class B roof covering.

**Exceptions:**

- Structurally dependent townhouses may use Class C roof coverings where all of the following conditions are met:
  - The townhouses are not more than two stories in height.
  - The townhouses do not have more than 6,000 square feet (557 m<sup>2</sup>) of projected roof area.
  - There is not less than 3 feet (914 mm) from the extremity of the roof to the exterior lot line or an assumed lot line on all sides except for street fronts.
- ~~Where adopted by the local municipality,~~ roof coverings for townhouses located in areas determined by the *municipality* to be "Wildfire Hazard Zones" shall be in accordance with Section R327.

### SECTION R327—WILDFIRE HAZARD MITIGATION

**R327.1 General.** ~~Where adopted by the local municipality,~~ the provisions of this section shall apply to *new dwellings* and their *accessory structures* ~~required by a local municipality via local ordinance~~ to be protected against *wildfire*.

~~Nothing in this code prevents a local municipality from modifying the requirements of this section for any lot, property or dwelling, or the removal, replacement or reconstruction of a dwelling within the jurisdiction, as provided in Section R404.10.~~

**R327.1.1 Local adoption.** The provisions of this section may be adopted in whole by a *municipality via local ordinance* without following ORS 455.040 or OAR 918-020-0370. ~~Where a municipality chooses to adopt these provisions locally, the following shall be included in the adopting ordinance:~~

- ~~Identification of areas subject to the additional construction standards of Section R327.~~
- ~~A transition plan or other measures to address subdivisions already under development at the time of local adoption.~~
- ~~A local appeal process for customers to follow. Where a municipality has previously adopted the provisions of Section R327 locally, the requirements of Section R327.1.1 do not apply and the existing local ordinance may continue without change to include those based on prior iterations of this section.~~

**R327.1.2 Notification.** Where a *municipality* adopts Section R327 locally, ~~or where a municipality has previously adopted Section R327 locally,~~ the *municipality* shall notify the State of Oregon, Building Codes Division, and ~~provide a copy of the locally adopted map identifying identify~~ areas of the jurisdiction where the additional construction standards of Section R327 are required.

**R327.1.3 Application.** Where ~~required adopted~~ by a *local municipality via local ordinance*, newly constructed *dwellings* ~~and their accessory structures, and new additions to existing dwellings and their accessory structures~~ located in areas designated by the *municipality* shall be protected against *wildfire* in accordance with this section. ~~Where existing exterior elements that are within the scope of this section are replaced in their entirety, the replacement shall be made in accordance with the provisions of this section.~~

**Exceptions:**

- Nonhabitable detached *accessory structures* with a floor area of not greater than 400 square feet (37.2 m<sup>2</sup>) located not less than 50 feet (15 240 mm) from all ~~other~~ structures on the lot ~~that contain habitable space~~.
- ~~Partial repairs made in accordance with Section R405.2.2.~~
- ~~Structures exempted by ORS 455.315.~~
- ~~Detached accessory membrane-covered frame structures~~

**R327.2 Definitions.** The following words and terms shall, for purposes of Section R327, have the meanings shown herein. See Chapter 2 for general definitions.

**HEAVY TIMBER.** For the use in this section, *heavy timber* shall be sawn lumber or glued-laminated wood with the smallest minimum nominal dimension of 4 inches (102 mm). *Heavy timber* walls or floors shall be sawn or glued-laminated planks spliced, tongue-and-groove or set close together and well spiked.

**IGNITION-RESISTANT MATERIAL.** A type of building material that resists ignition or sustained flaming combustion sufficiently so as to reduce losses from wildland urban interface conflagrations under worst-case weather and fuel conditions with *wildfire* exposure of burning embers and small flames. Such materials include any product designed for exterior exposure that, when tested in accordance with ASTM E84 or UL 723 for surface burning characteristics of building materials, extended to a 30-minute duration, exhibits a flame spread index of not more than 25, shows no evidence of significant progressive combustion, and whose flame front does not progress more than 10<sup>1</sup>/<sub>2</sub> feet (3200 mm) beyond the centerline of the burner at any time during the test.

**NONCOMBUSTIBLE MATERIAL.** Any material that in the form in which it is used and under the conditions anticipated will not ignite, burn, support combustion or release flammable vapors when subjected to fire or heat in accordance with ASTM E 136.

**WILDFIRE.** Any uncontrolled fire spreading through vegetative fuels that threatens to destroy life, property or resources.

**WILDFIRE EXPOSURE.** One or a combination of circumstances exposing a structure to ignition, including radiant heat, convective heat, direct flame contact and burning embers being projected by a vegetation fire to a structure and its immediate environment.

**R327.3 Roofing.** Roofing shall be asphalt shingles in accordance with Section R905.2, slate shingles in accordance with Section R905.6, metal roofing in accordance with Section R905.4, tile, clay or concrete shingles in accordance with Section R905.3 or other approved roofing that is deemed to be equivalent to a minimum Class B-rated roof assembly. Wood shingle and shake roofs are not permitted on structures ~~in areas designated by the municipality that fall within the scope of this section~~.

Where the roof profile allows a space between the roof covering and roof decking, the spaces shall be constructed to prevent the intrusion of flames and embers, be fireblocked with *approved* materials, or have one layer of minimum 72-pound (32.6 kg) mineral-surfaced nonperforated cap sheet complying with ASTM D3909 installed over the combustible decking.

Where valley flashing is installed, the flashing shall be not less than 0.019-inch (0.48 mm) No. 26 gage galvanized sheet corrosion-resistant metal installed over not less than one layer of minimum 72-pound (32.6 kg) mineral-surfaced nonperforated cap sheet complying with ASTM D3909 not less than 36-inch-wide (914 mm) running the full length of the valley.

**R327.3.1 Gutters and downspouts.** Where ~~provided, required,~~ ~~roof~~-gutters and ~~downspouts~~ shall be constructed of *noncombustible materials* and be provided with ~~an approved~~ means to prevent accumulation of leaves and debris in the gutter.

**R327.3.2 Ventilation.** Where provided, the minimum net area of ventilation openings for enclosed attics, enclosed soffit spaces, enclosed rafter spaces and underfloor spaces shall be in accordance with Sections R408 and R806.

All ventilation openings shall be covered with noncombustible corrosion-resistant metal wire mesh, vents designed to resist the intrusion of burning embers and flame, or other approved materials or devices.

Ventilation mesh and screening shall be a minimum of <sup>1</sup>/<sub>16</sub>-inch (1.6 mm) and a maximum of <sup>1</sup>/<sub>8</sub>-inch (3.2 mm) in any dimension.

**R327.3.2.1 Eaves, soffits and cornices.** Ventilation openings shall not be installed on the underside of eaves, soffits or cornices.

**Exceptions:**

- The *building official* may approve eave, soffit or cornice vents that are manufactured to resist the intrusion of flame and burning embers.
- Ventilation openings complying with the requirements of Section R327.3.2 may be installed on the underside of eaves, soffits or cornices where the opening is located 12 feet (3658 mm) or greater above *grade* or the surface below.

**R327.3.3 Exterior walls.** The *exterior wall covering* or wall assembly shall comply with one of the following requirements:

- Noncombustible material*.
- Ignition-resistant material*.
- Heavy timber* assembly.
- Log wall construction assembly.
- Wall assemblies that have been tested in accordance with the test procedures for a 10-minute direct flame contact exposure test set forth in ASTM E2707, complying with the conditions of acceptance listed in Section R327.3.3.2.

**Exception:** Any of the following shall be deemed to meet the assembly performance criteria and intent of this section:

- One layer of <sup>1</sup>/<sub>2</sub>-inch (15.9 mm) Type X exterior gypsum sheathing applied behind the *exterior wall covering* or cladding on the exterior side of the framing.
- The exterior portion of a 1-hour fire-resistance-rated *exterior wall* assembly designed for exterior fire exposure, including assemblies using exterior gypsum panel and sheathing products listed in the Gypsum Association *Fire Resistance and Sound Control Design Manual*.

**R327.3.3.1 Extent of exterior wall covering.** *Exterior wall coverings* shall extend from the top of the foundation to the roof and terminate at 2-inch (50.8 mm) nominal solid wood blocking between rafters at all roof overhangs, or in the case of enclosed eaves or soffits, shall terminate at the underside of the enclosure.

**R327.3.3.2 Conditions of acceptance.** ASTM E2707 tests shall be conducted in triplicate and the following conditions of acceptance shall be met. If any one of the three replicates do not meet the conditions of acceptance, three additional tests shall be conducted. All additional tests shall meet the following conditions of acceptance:

- Absence of flame penetration through the wall assembly at any time during the test.
- Absence of evidence of glowing combustion on the interior surface of the assembly at the end of the 70-minute test.

**R327.3.4 Overhanging projections.** All exterior projections (exterior balconies, carports, decks, patio covers, porch ceilings, unenclosed roofs and floors, overhanging buildings and similar architectural appendages and projections) shall be protected as specified in this section.

**R327.3.4.1 Enclosed roof eaves, soffits and cornices.** The exposed underside of rafter or truss eaves and enclosed soffits, where any portion of the framing is less than 12 feet (3658 mm) above *grade* or similar surface below, shall be protected by one of the following:

- Noncombustible material*.
- Ignition-resistant material*.
- One layer of <sup>1</sup>/<sub>2</sub>-inch (15.9 mm) Type X exterior gypsum sheathing applied behind an exterior covering on the underside of the rafter tails, truss tails or soffit.
- The exterior portion of a 1-hour fire-resistance-rated *exterior wall* assembly applied to the underside of the rafter tails or soffit, including assemblies using exterior gypsum panel and sheathing products listed in the Gypsum Association *Fire Resistance and Sound Control Design Manual*.
- Soffit assemblies with an underside surface that meets the performance criteria in Section R327.3.4.5 when tested in accordance ASTM E2957.

**Exceptions:** The following materials do not require protection required by this section:

- Eaves and soffits where all portions of the framing members are 12 feet (3658 mm) or greater above *grade*, and 2-inch (610 mm) nominal eave fireblocking is provided between roof framing members from the wall top to the underside of the roof sheathing.
- Gable end overhangs and roof assembly projections beyond an *exterior wall* other than at the lower end of the rafter tails.
- Fascia end overhangs and other architectural trim boards.

**R327.3.4.2 Exterior patio and porch ceilings.** The exposed underside of exterior patio and porch ceilings greater than 200 square feet (18.58 m<sup>2</sup>) in area and less than 12 feet (3658 mm) above *grade* shall be protected by one of the following:

- Noncombustible material*.
- Ignition-resistant material*.
- One layer of <sup>1</sup>/<sub>2</sub>-inch (15.9 mm) Type X exterior gypsum sheathing applied behind the exterior covering on the underside of the ceiling.
- The exterior portion of a 1-hour fire-resistance-rated *exterior wall* assembly applied to the underside of the ceiling assembly, including assemblies using exterior gypsum panel and sheathing products listed in the Gypsum Association *Fire Resistance and Sound Control Design Manual*.
- Porch ceiling assemblies with a horizontal underside that meet the performance criteria in Section R327.3.4.5 when tested in accordance with the test procedures set forth in ASTM E2957.

**Exception:** Architectural trim boards.

**R327.3.4.3 Floor projections.** The exposed underside of cantilevered floor projections less than 12 feet (3658 mm) above *grade* or the surface below shall be protected by one of the following:

- Noncombustible material*.
- Ignition-resistant material*.
- One layer of <sup>1</sup>/<sub>2</sub>-inch (15.9 mm) Type X exterior gypsum sheathing applied behind an exterior covering on the underside of the floor projection.
- The exterior portion of a 1-hour fire-resistance-rated *exterior wall* assembly applied to the underside of the floor projection, including assemblies using exterior gypsum panel and sheathing products listed in the Gypsum Association *Fire Resistance and Sound Control Design Manual*.
- An assembly that meets the performance criteria in Section R327.3.4.5 when tested in accordance with ASTM E2957.

**Exception:** Architectural trim boards.

**R327.3.4.4 Underfloor protection.** The underfloor area of elevated structures shall be enclosed to *grade* in accordance with the requirements of this section, or the underside of the exposed underfloor shall be protected by one of the following:

- Noncombustible material*.
- Ignition-resistant material*.
- One layer of <sup>1</sup>/<sub>2</sub>-inch (15.9 mm) Type X exterior gypsum sheathing applied behind an exterior covering on the underside of the floor assembly.
- The exterior portion of a 1-hour fire-resistance-rated *exterior wall* assembly applied to the underside of the floor, including assemblies using exterior gypsum panel and sheathing products listed in the Gypsum Association *Fire Resistance and Sound Control Design Manual*.
- An assembly that meets the performance criteria in Section R327.3.4.5 when tested in accordance with ASTM E2957.

**Exception:** *Heavy timber* structural columns and beams do not require protection.

**R327.3.4.5 Conditions of acceptance.** ASTM E2957 tests shall be conducted in triplicate, and the following conditions of acceptance shall be met. If any one of the three replicates do not meet the conditions of acceptance, three additional tests shall be conducted. All additional tests shall meet the following conditions of acceptance:

- Absence of flame penetration of the eaves or horizontal projection assembly at any time during the test.
- Absence of structural failure of the eaves or horizontal projection subassembly at any time during the test.
- Absence of sustained combustion of any kind at the conclusion of the 40-minute test.

**R327.3.5 Walking surfaces.** Deck, porch and balcony walking surfaces located greater than 30 inches (762 mm) and less than 12 feet (3658 mm) above *grade* or the surface below shall be constructed with one of the following materials:

- Materials that comply with the performance requirements of Section R327.3.5.1 when tested in accordance with both ASTM E2632 and ASTM E2726.
- Ignition-resistant* materials that comply with the performance requirements of Section R327.2 when tested in accordance with ASTM E84 or UL 723.
- Exterior fire-retardant-treated wood.
- Noncombustible material*.
- Any material that complies with the performance requirements of Section R327.3.5.2 when tested in accordance with ASTM E2632, where the *exterior wall covering* of the structure is noncombustible or *ignition-resistant* material.
- Any material that complies with the performance requirements of ASTM E2632, where the *exterior wall covering* of the structure is noncombustible or *ignition-resistant* material.

**Exception:** *Wall covering* material may be of any material that otherwise complies with this chapter where the decking surface material complies with the performance requirements ASTM E84 with a Class B flame spread rating.

**Exception:** Walking surfaces of decks, porches and balconies not greater than 200 square feet (18.58 m<sup>2</sup>) in area, where the surface is constructed of nominal 2-inch (51 mm) lumber.

**R327.3.5.1 Requirements for Section R327.3.6, Item 1.** The material shall be tested in accordance with ASTM E2632 and ASTM E2726, and shall comply with the conditions of acceptance in Sections R327.3.5.1.1 and R327.3.5.1.2. The material shall also comply with the performance requirements of Section R327.2 for ignition-resistant material when tested in accordance with ASTM E84 or UL 723.

**R327.3.5.1 Conditions of acceptance.** ASTM E2632 tests shall be conducted in triplicate and the following conditions of acceptance shall be met. If any one of the three replicates do not meet the conditions of acceptance, three additional tests shall be conducted. All additional tests shall meet the following conditions of acceptance:

- Peak heat release rate of less than or equal to 25 kW/ft<sup>2</sup> (269 kW/m<sup>2</sup>).

2023 OREGON RESIDENTIAL SPECIALTY CODE

Wildfire Hazard Mitigation-1

2023 OREGON RESIDENTIAL SPECIALTY CODE

Wildfire Hazard Mitigation-2

2023 OREGON RESIDENTIAL SPECIALTY CODE

Wildfire Hazard Mitigation-3

2023 OREGON RESIDENTIAL SPECIALTY CODE

Wildfire Hazard Mitigation-4

- Absence of sustained flaming or glowing combustion of any kind at the conclusion of the 40-minute observation period.
- Absence of falling particles that are still burning when reaching the burner or floor.

**R327.3.5.1.2 Conditions of acceptance.** ASTM E2762 tests shall be conducted in triplicate and the following conditions of acceptance shall be met. If any one of the three replicates do not meet the conditions of acceptance, three additional tests shall be conducted. All of the additional tests shall meet the following conditions of acceptance:

- Absence of sustained flaming or glowing combustion of any kind at the conclusion of the 40-minute observation period.
- Absence of falling particles that are still burning when reaching the burner or floor.

**R327.3.5.2 Requirements for Section R327.3.6, Item 6.** The material shall be tested in accordance with ASTM E2632 and shall comply with the following conditions of acceptance. The test shall be conducted in triplicate and the peak heat release rate shall be less than or equal to 25 kW/ft<sup>2</sup> (269 kW/m<sup>2</sup>). If any one of the three replicates do not meet the conditions of acceptance, three additional tests shall be conducted. All of the additional tests shall meet the conditions of acceptance.

**R327.3.6 Glazing.** Exterior windows, windows within exterior doors, and skylights shall be tempered glass, multilayered glazing panels, glass block or have a fire-resistance rating of not less than 20 minutes.

For questions about the 2023 ORSC, visit the division website to [contact a building code specialist](#).

2023 OREGON RESIDENTIAL SPECIALTY CODE

Wildfire Hazard Mitigation-5

# Lateral and Gravity Loads Analysis (Engineering Design)

3/6/2026

Deschutes Bungalow ADU (Pre-Approved)  
City Limits  
Bend, OR

## Project Specifications

### Plan Evaluated

SJC "Deschutes Bungalow"

### Design Summary

Occupancy Group R, Construction Type VB

### Structural Drawings

S1 Foundation	(3/6/2026)
S2 Subfloor Framing	(3/6/2026)
S3 Main Floor Framing	(3/6/2026)
S4 Main Level Lateral	(3/6/2026)
S5 Details	(3/6/2026)

### Orientation

See drawings for orientation.

### Design Parameters

Basic Wind Speed	99 MPH, Exp C	[IBC]
Seismic Design	0.38g	[ASCE7-16 Zip Code]
Soil Bearing	1500 PSF	[Table R401.4.1]
Ground Snow Load	50 PSF	[SEAO-ASCE7-16]
Roof Dead Load	20 PSF	
Floor Live Load	40 PSF	
Floor Dead Load	12 PSF	

NOTE: All Specifications are minimums. Upgraded size and quality is acceptable.

WARNING: It is the responsibility of the user of this document to ensure that all the technical information is properly transferred to the applicable construction documents and that it is properly implemented during the construction of the structure. Failure to incorporate all the requirements of this design may invalidate the integrity of the structure and release responsibility from the engineer of record.

**BANTON**  
ENGINEERING, INC.

Garrett J. Banton, PE  
Engineering License #87488PE (Oregon)  
3008 NE Charleston Ct.  
Bend, Oregon 97701  
Business Phone: (541) 306-7893



EXPIRES: 12/31/2027

# Wind and Seismic Force Calculation

Based on IBC and ASCE 7-16 Directional Procedure, Chapter 27.2

## Wind Pressure Boundary Conditions

Risk Category	II	
Ultimate Wind Speed	99 Mph	[IBC]
Wind directionality Factor (Kd)	0.85	[ASCE 7-16, Table 26.6-1]
Wind exposure Category	C	[ASCE 7-16, 26.7]
Topographic Factor (Kzt)	$1 \frac{H}{L} < 0.2$	[ASCE 7-16, Figure 26.8-1]
Gust Effect Factor (G)	0.85	[ASCE 7-16, 26.9]
Enclosure Classification	Enclosed	[ASCE 7-16, 26.11]
Internal Pressure Coefficient (Gcpi)	0.18	[ASCE 7-16, 26.11]
Velocity Pressure Exposure Coefficient (Kh)	0.849	[ASCE 7-16, Table 27.3-1]
Velocity Pressure (qh)	18.1 Psf	
External Pressure Coefficients (Cp) [Walls, Roof]	0.8, 0.4	[ASCE 7-16, Table 27.3-1]
Wind Pressure (p)	21.4 Psf	
Flat Walls Use	21.4 Psf	

## Direction F/B Wind Pressure

Flat Wall Height	$h = 9'$	
Wall Horizontal	$w = 40'$	
Wall Wind Force	$21.4 \text{ Psf} \times 9' \times 40' = 7704 \text{ lb}$	[ASCE 7-16, 27.1.5]
Slope Roof Height	$h = 8.5'$ (Pitch: 6:12)	
Roof Horizontal	$w = 40'$	
Roof Wind Force	$21.4 \text{ Psf} \times 8.5' \times 40' = 7276 \text{ lb}$	
Average Wind Pressure	21.4 Psf (Weighted Average)	
Total Wind Pressure	$7704 \text{ lb} + 7276 \text{ lb} = 14980 \text{ lb}$	

## Direction L/R Wind Pressure

Flat Wall Height	$h = 13.5'$	
Wall Horizontal	$w = 27'$	
Wall Wind Force	$21.4 \text{ Psf} \times 13.5' \times 27' = 7800.3 \text{ lb}$	[ASCE 7-16, 27.1.5]
Slope Roof Height	$h = 0'$ (Pitch: 6:12)	
Roof Horizontal	$w = 27'$	
Roof Wind Force	$21.4 \text{ Psf} \times 0' \times 27' = 0 \text{ lb}$	
Average Wind Pressure	21.4 Psf (Weighted Average)	
Total Wind Pressure	$7800.3 \text{ lb} + 0 \text{ lb} = 7800.3 \text{ lb}$	

## Seismic Force Calculation

Design Short-Period Spectral Acceleration ( $S_{ds}$ )	0.38g	[ASCE 7-16, Ch 11.4.5]
Seismic Response Coefficient ( $C_s$ )	0.0588	[ASCE 7-16, CI 12.8.1.1]
Base Shear: $V = C_s \times W = 0.0588 \times 58536 = 3442 \text{ lb}$		

## Governing Forces

**14980 lb (F/B) - Wind Governs**

**7800.3 lb (L/R) - Wind Governs**



# Roof Snow Load Calculation

Based on 2019 OSSC 1603.1.3, ASCE7-16, Chapter 7, SEAO

Ground Snow Load Adjustment	0.007 psf/ft (East of the Cascades)	[OSSC 1608, Table 7-2 ]
Exposure Factor (Ce)	1 (Exposure C Part Sheltered)	[ASCE7-16, Table 7-2]
Thermal Factor (Ct)	1 (Heated Structure)	[ASCE7-16, Table 7-3]
Importance Factor (I)	1 (Category II Structure)	[Section 7.3, Table 1.5.2]
Cold Roof Slope Factor (Cs)	1 (Fig 7-2a w/ 6:12 pitch)	[ASCE7-16 Section 7.4]

Structure Elevation	4000' ASL	
Ground Snow Load (pg)	50 psf (model at 4000' ASL)	[ASCE7-16, SEAO]
Adjusted Ground Snow Load (pga)	$50 \text{ psf} + 0.007(4000' - 4000') = 50 \text{ psf}$	[OSSC 1608, Table 7-2]
Flat Roof Snow Load (pf)	$0.7 \times 1 \times 1 \times 1 \times 50 = 35 \text{ psf}$	[ASCE7-16 Section 7.3]
Sloped Roof Snow Load (ps)	$1 \times 35 \text{ psf} = 35 \text{ psf}$	[ASCE7-16 Section 7.4]
<b>Snow Load Used</b>	<b>35 psf</b>	
<b>Unheated Roof Option</b>	<b>45 psf</b>	

**Not for Construction**  
 These plans are licensed by the City of Bend for permitting within the Bend City Limits.  
 For use of these plans, apply for permits directly with the City of Bend.

# Foundation Wall Footings

Note: The following footing and stem wall sizes are minimums and were used in the gravity loadings analysis. All rebar to be specified on drawing schedules.

## WF1 - MAX EXTERIOR WALL FOOTINGS

### 12"W X 6"D FTG W/ 6"W x 24"D STEM WALL

Stem Wall (6")	150 plf	(0SL/0LL/150DL)
Roof (16X)	880 plf	(560SL/0LL/320DL)
Floor (7X)	364 plf	(0SL/280LL/84DL)
Wall (9')	90 plf	(0SL/0LL/90DL)
Total:	1484 plf	(560SL/280LL/644DL)

**Not for Construction**  
These plans are licensed by the City of Bend for permitting within the Bend City limits.  
For use of these plans, apply for permits directly with the City of Bend.



<b>Client:</b> SIERRA JAMES CONSTRUCTION	<b>Author:</b> Allison Rymut	<b>Date:</b> Jan 30, 2026
<b>Project:</b> DESCHUTES BUNGALOW		<b>Job #:</b>
<b>Address:</b>		<b>Subject:</b> WIND (LATERAL)
<b>References:</b> ASCE 7-16		

Summary

Zones

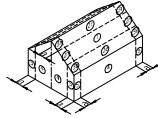

Some wind pressures are below 16 psf which is the code-required minimum. The horizontal red lines on the diagram below indicate the minimum positive/negative wind pressures.

Note:

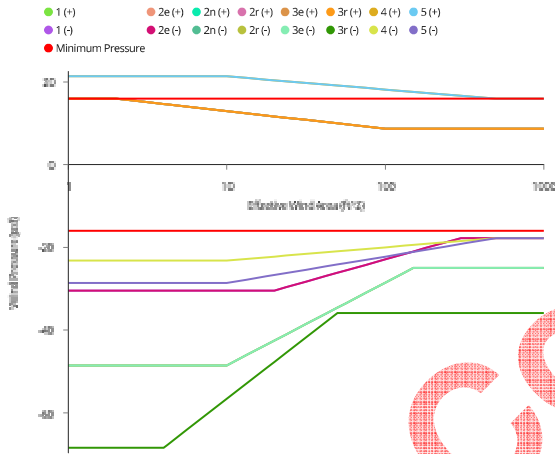

Corner Zone Width

$$a = 3 \text{ ft}, 0 \text{ in}$$

Wind Pressures

$$p =$$

Zone	Positive Wind Pressure $p$ (psf)	Negative Wind Pressure $p$ (psf)
1	16	-30.4
2e	16	-30.4
2n	16	-48.5
2r	16	-48.5
3e	16	-48.5
3r	16	-68.4
4	21.4	-23.2
5	21.4	-28.6

Project Defaults

Building Code

International Residential Code (IRC) 2021

Basic Wind Speed

$$V = 99 \text{ mi/hr}$$

Exposure Category

C: Open terrain with scattered obstructions

Key Properties

Basic Wind Speed

$$V = 99 \text{ mi/hr}$$

Exposure Category

C

Effective Roof Member Wind Area

$$A_{\text{roof}} = 1 \text{ ft}^2$$

Effective Wall Member Wind Area

$$A_{\text{wall}} = 1 \text{ ft}^2$$

Building Properties

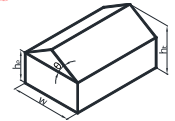

Roof Pitch

$$\alpha = 6 : 12$$

Roof Eave Height

$$h_e = 10 \text{ ft}, 6 \text{ in}$$

Roof Mean Height

$$h = 13 \text{ ft}, 10.5 \text{ in}$$

Width (Perpendicular to Ridge)

$$w = 27 \text{ ft}$$

Length (Parallel to Ridge)

$$\ell = 40 \text{ ft}$$

Enclosure Type

Enclosed

Terrain Properties (ASCE 7-16, CI 26.7-9)

Warning:

No address is specified in Project Details. No elevation will be determined and the elevation factor  $K_e$  will conservatively be taken as 1.0. This can be changed by setting an address in Project Details or manually entering a ground elevation.

Wind Load Parameters (ASCE 7-16, CI 26.6-10)

Wind Directionality Factor

$$K_d = 0.85$$

Topographic Factor

$$K_{zt} = 1$$

Ground Elevation Factor

$$K_e = 1$$

Velocity Pressure Exposure Coefficient

$$K_h = 0.849$$

Velocity Pressure

$$q_h = 18.1 \text{ psf}$$

Comments



<b>Client:</b> SIERRA JAMES CONSTRUCTION	<b>Author:</b> Allison Rymut	<b>Date:</b> Jan 30, 2026
<b>Project:</b> DESCHUTES BUNGALOW		<b>Job #:</b>
<b>Address:</b>		<b>Subject:</b> SEISMIC (LATERAL) <span style="border: 1px solid green; border-radius: 5px; padding: 2px;">PASS</span>
<b>References:</b> ASCE 7-16		

Summary

Number of Stories

$n_{story} = 2$

Design Short-Period Spectral Acceleration	$S_{DS} = 0.382$
Design Long-Period Spectral Acceleration	$S_{D1} = 0.44$
Seismic Design Category	$SDC = D$
Seismic Base Shear	$V = 3442 \text{ lb}$

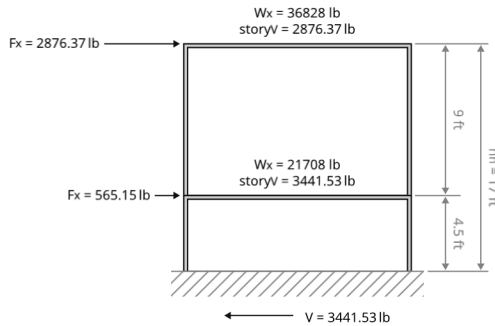

Project Defaults Override

Override Project Defaults?	Yes
Building Risk Category	II - Regular Building
Site Class	D - Default
Short-Period Spectral Acceleration	$S_{s,input} = 0.384$
Long-Period Spectral Acceleration	$S_{1,input} = 0.2$
Long-Period Transition Period	$T_{L,input} = 16 \text{ s}$

Site Parameters (ASCE 7-16)

Building Risk Category	$RC = \text{II}$
Site Class	$SC = \text{D-default}$
Short-Period Spectral Acceleration	$S_s = 0.384$
Long-Period Spectral Acceleration	$S_1 = 0.2$
Long-Period Transition Period	$T_L = 16 \text{ s}$

Key Building Properties (ASCE 7-16)

Seismic Force-Resisting System	15. Light-frame (wood) walls sheathed with wood structural panels rated for shear resistance
--------------------------------	--

SFRS Properties (ASCE 7-16, CI 12)

Building System Height Limit (ft)	Height Limit = 65
-----------------------------------	-------------------

Equivalent Lateral Force (ELF) Procedure (ASCE 7-16, CI 12.8)

Approximate Fundamental Period	$T_a = 0.141 \text{ s}$
Building Fundamental Period	$T = 0.141 \text{ s}$
Total Structural SFRS Height	$h_n = 13 \text{ ft}, 6 \text{ in}$
Total Effective Seismic Weight	$W_{total} = 58\,536 \text{ lb}$
Seismic Importance Factor	$I_e = 1$
Seismic Response Coefficient	$C_s = 0.0588$

Not for Construction  
 These plans are licensed by the City of Bend for permitting within the Bend City Limits.  
 Use of these plans, apply for permits directly with the City of Bend.



<b>Client:</b> SIERRA JAMES CONSTRUCTION	<b>Author:</b> Allison Rymut	<b>Date:</b> Jan 30, 2026
<b>Project:</b> DESCHUTES BUNGALOW		<b>Job #:</b>
<b>Address:</b>	<b>Subject:</b> 1WL1/1WL6 #4 SHEAR WALL MAX (LATERAL) <span style="border: 1px solid green; border-radius: 5px; padding: 2px;">PASS</span>	
<b>References:</b> AWC SDPWS 2021, AWC NDS 2018		

Summary

Governing Wind Shear Load	$V_{0.6W} = 509$ lb
<span style="border: 1px solid green; border-radius: 5px; padding: 2px;">43%</span> Governing Allowable Wind Shear	$V_{a,W} = 1176$ lb
Governing Seismic Shear Load	$V_{0.7E} = 0$ lb
<span style="border: 1px solid green; border-radius: 5px; padding: 2px;">0%</span> Governing Allowable Seismic Shear	$V_{a,E} = 840$ lb

Chord Summary

Required Number of Plies in Chord	$n_{plies,chords} = 2$
Maximum Chord Tension Load	$T_{chord} = 1832$ lb
<span style="border: 1px solid green; border-radius: 5px; padding: 2px;">10%</span> Allowable Chord Tension	$T_a = 17940$ lb
Maximum Chord Compression Load	$C_{chord} = 2089$ lb
<span style="border: 1px solid green; border-radius: 5px; padding: 2px;">20%</span> Allowable Chord Compression	$C_a = 10312$ lb

Holdown Design

Holdown Designation	HDUE3-SDS3
<span style="border: 1px solid green; border-radius: 5px; padding: 2px;">48%</span> Holdown Capacity Check	$HD/HD' = 1832$ lb / 3790 lb
Required Wood Fasteners	$WF = (7) 0.25 \times 3$ SDS

Shear Wall Diagram

== Holdowns Required



Shear Wall Type (SDPWS 2021, CI 4.3.2)

Shear Wall Type	Segmented
Sheathing & Nail Pattern	7/16" OSB/Plywood, 8d@4"
Sheathed Sides	One Side
Blocking at Panel Edges	Blocked
Nail Spacing in Field of Panels	$s_{field} = 12$ in

Studs

Stud Size & Grade	2x6 D.Fir-L No. 2
Stud Spacing	$s_{stud} = 16$ in
Default Number of Plies in Chord	$n_{plies,default} = 2$

Design Criteria

Service Condition	Service? = Dry
Studs are Incised?	Incised? No

Stud Properties

Depth	$d_{stud} = 5.5$ in
Gross Cross-Sectional Area of One Stud	$A_{g,stud} = 8.25$ in <sup>2</sup>
Net Cross-Sectional Area of One Stud	$A_{n,stud} = 7.5$ in <sup>2</sup>
Base Compression Parallel to Grain Allowable Stress	$F_{c,stud} = 1350$ psi
Base Compression Perpendicular to Grain Allowable Stress	$F_{c\perp,stud} = 625$ psi
Base Tension Parallel to Grain Allowable Stress	$F_{t,stud} = 575$ psi
Base Minimum Elastic Modulus	$E_{min,stud} = 580000$ psi
Base Modulus of Elasticity	$E_{stud} = 1.60 \times 10^6$ psi

Stud Elastic Modulus (NDS 2018 2.3)

Adjusted Minimum Elastic Modulus (X-axis)	$E'_{min} = 580000$ psi
Adjusted Modulus of Elasticity	$E'_{stud} = 1.60 \times 10^6$ psi

Chord Tension Design (NDS 2018 3.8)

Duration Factor	$C_{D,t} = 1.6$
Size Factor	$C_{F,t} = 1.3$
Adjusted Tension Strength	$F'_t = 1196$ psi

Capacity in Pure Axial Loading (NDS 2018 Section 3.7)

Critical Duration Factor - Pure Axial Loading	$C_{D,c} = 1.6$
Size Factor	$C_{F,c} = 1.1$
Fully Braced Compression Strength	$F_c^* = 2376$ psi
Governing Slenderness	$(\ell_c/d) = 19.8$
Adjusted Compression Strength	$F'_c = 1046$ psi

Bearing Perpendicular to Stud (NDS 2018 Section 3.10)

Adjusted Bearing Design Value	$F'_{c\perp} = 625$ psi
-------------------------------	-------------------------

Holdown Capacity

Holdown Capacity	$Holdown_{capacity} = 3790$ lb
------------------	--------------------------------

Comments





<b>Client:</b> SIERRA JAMES CONSTRUCTION	<b>Author:</b> Allison Rymut	<b>Date:</b> Jan 30, 2026
<b>Project:</b> DESCHUTES BUNGALOW		<b>Job #:</b>
<b>Address:</b>		<b>Subject:</b> 1H1 (1 LEVEL BEAMS) <span style="border: 1px solid green; border-radius: 5px; padding: 2px;">PASS</span>
<b>References:</b> NDS 2018 (ASD)		

Summary

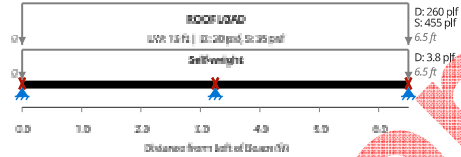
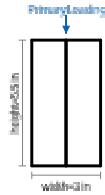

Member	2 plies - 2x6 D.Fir-L No. 2	
<span style="border: 1px solid green; border-radius: 5px; padding: 2px;">56%</span> Moment Utilization	$M/M' =$	-949 lbft / 1691 lbft
<span style="border: 1px solid green; border-radius: 5px; padding: 2px;">64%</span> Shear Utilization	$V/V' =$	1460 lb / 2277 lb
<span style="border: 1px solid green; border-radius: 5px; padding: 2px;">46%</span> Bearing Utilization	$R/R' =$	2920 lb / 6328 lb
Minimum Bearing Length (End Supports)	$\ell_{b,min,end} =$	0.467 in
Minimum Bearing Length (Int Supports)	$\ell_{b,min,int} =$	1.38 in
<span style="border: 1px solid green; border-radius: 5px; padding: 2px;">4%</span> Governing Live / Short-Term Deflection	$\delta_{ST} =$	-0.00714 in (L/5464)

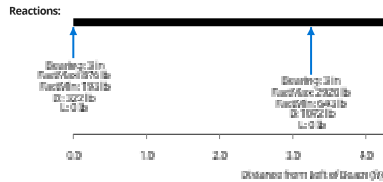

Key Properties

Beam Plan Length	$D_x =$	6.5 ft
Continuous Bracing for Lateral Torsional Buckling		No Continuous Bracing

Loads

Design Conditions

International Residential Code (IRC) 2021

Member Properties

Cross-Sectional Area	$A =$	16.5 in <sup>2</sup>
Strong Axis Moment of Inertia	$I_{xx} =$	41.6 in <sup>4</sup>
Section Modulus	$S =$	15.1 in <sup>3</sup>
Base Allowable Bending Stress	$F_b =$	900 psi
Base Allowable Shear Stress	$F_v =$	180 psi
Base Perpendicular Compression Allowable Stress	$F_{c\perp} =$	625 psi
True Modulus of Elasticity	$E_{true} =$	$1.60 \times 10^6$ psi
Apparent Modulus of Elasticity	$E_{app} =$	$1.60 \times 10^6$ psi
Modulus of Elasticity for Deflections	$E =$	$1.60 \times 10^6$ psi

Elastic Modulus (NDS 2018 2.3)

Adjusted Modulus of Elasticity	$E' =$	$1.60 \times 10^6$ psi
--------------------------------	--------	------------------------

Section Bending (NDS 2018 2.3)

Size Factor	$C_{F,b} =$	1.3
Incising Factor	$C_{i,b} =$	1

Positive Bending (NDS 2018 2.3)

Adjusted Bending Strength - Positive Bending	$F_b^{'+} =$	1342 psi
--	--------------	----------

Negative Bending (NDS 2018 2.3)

Adjusted Bending Strength - Negative Bending	$F_b'^{-} =$	1342 psi
--	--------------	----------

Shear Design (NDS 2018 3.4)

Adjusted Shear Strength	$F_v' =$	207 psi
-------------------------	----------	---------

Bearing (NDS 2018 3.10)

Base Bearing Strength	$F'_{c\perp}/C_b =$	625 psi
-----------------------	---------------------	---------

Comments

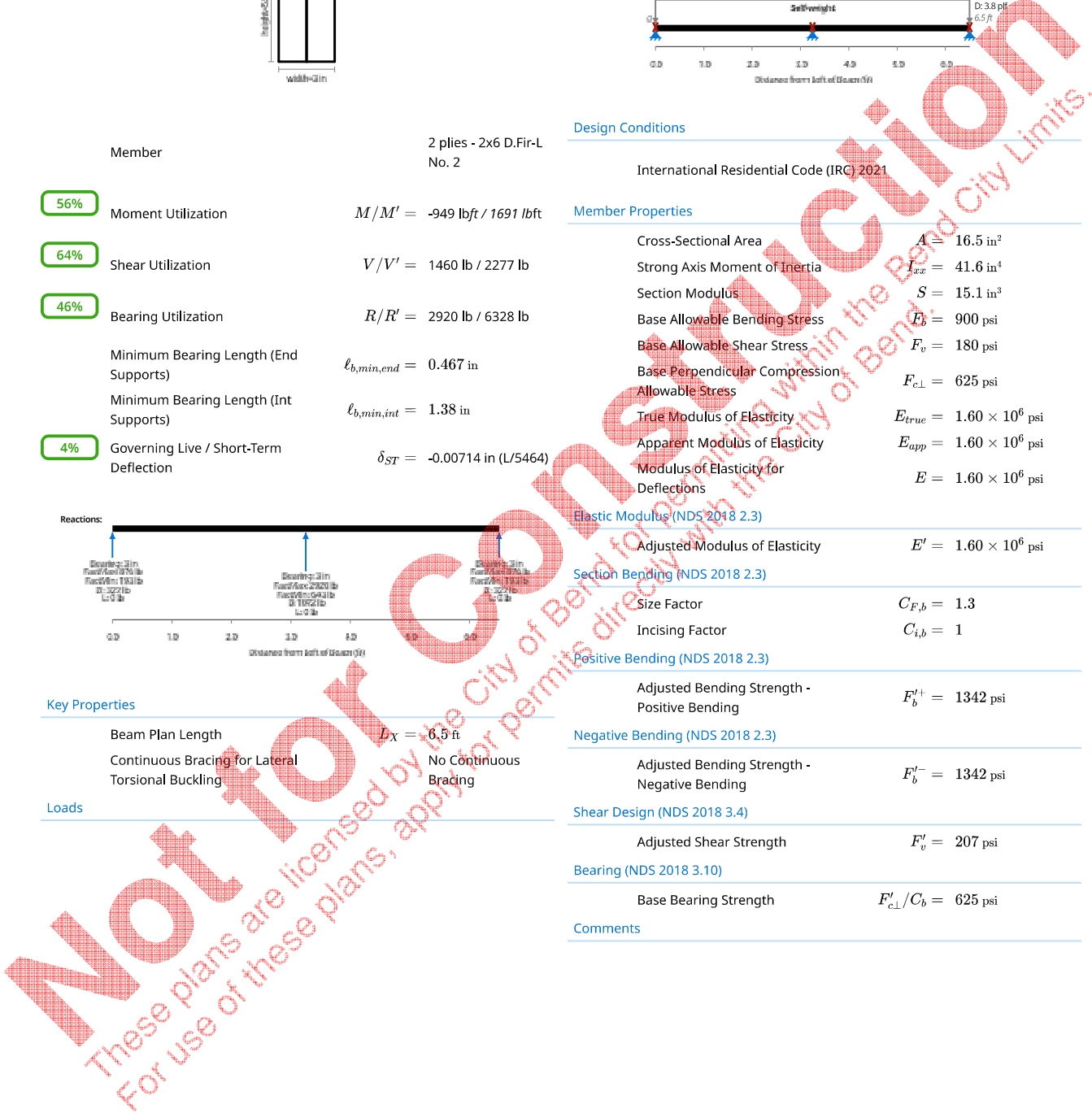



<b>Client:</b> SIERRA JAMES CONSTRUCTION	<b>Author:</b> Allison Rymut	<b>Date:</b> Jan 30, 2026
<b>Project:</b> DESCHUTES BUNGALOW		<b>Job #:</b>
<b>Address:</b>		<b>Subject:</b> 1H2 (1 LEVEL BEAMS) <span style="border: 1px solid green; border-radius: 5px; padding: 2px;">PASS</span>
<b>References:</b> NDS 2018 (ASD)		

Summary

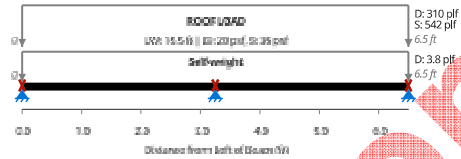
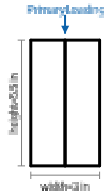

Member	2 plies - 2x6 D.Fir-L No. 2	
<span style="border: 1px solid green; border-radius: 5px; padding: 2px;">67%</span> Moment Utilization	$M/M' =$	-1131 lbft / 1691 lbft
<span style="border: 1px solid green; border-radius: 5px; padding: 2px;">76%</span> Shear Utilization	$V/V' =$	1739 lb / 2277 lb
<span style="border: 1px solid green; border-radius: 5px; padding: 2px;">55%</span> Bearing Utilization	$R/R' =$	3479 lb / 6328 lb
Minimum Bearing Length (End Supports)	$\ell_{b,min,end} =$	0.557 in
Minimum Bearing Length (Int Supports)	$\ell_{b,min,int} =$	1.65 in
<span style="border: 1px solid green; border-radius: 5px; padding: 2px;">5%</span> Governing Live / Short-Term Deflection	$\delta_{ST} =$	-0.00851 in (L/4583)

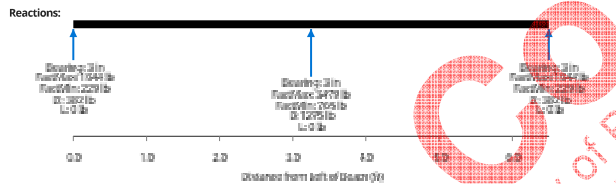

Key Properties

Beam Plan Length	$L_x =$	6.5 ft
Continuous Bracing for Lateral Torsional Buckling		No Continuous Bracing

Loads

Design Conditions

International Residential Code (IRC) 2021

Member Properties

Cross-Sectional Area	$A =$	16.5 in <sup>2</sup>
Strong Axis Moment of Inertia	$I_{xx} =$	41.6 in <sup>4</sup>
Section Modulus	$S =$	15.1 in <sup>3</sup>
Base Allowable Bending Stress	$F_b =$	900 psi
Base Allowable Shear Stress	$F_v =$	180 psi
Base Perpendicular Compression Allowable Stress	$F_{c\perp} =$	625 psi
True Modulus of Elasticity	$E_{true} =$	$1.60 \times 10^6$ psi
Apparent Modulus of Elasticity	$E_{app} =$	$1.60 \times 10^6$ psi
Modulus of Elasticity for Deflections	$E =$	$1.60 \times 10^6$ psi

Elastic Modulus (NDS 2018 2.3)

Adjusted Modulus of Elasticity	$E' =$	$1.60 \times 10^6$ psi
--------------------------------	--------	------------------------

Section Bending (NDS 2018 2.3)

Size Factor	$C_{F,b} =$	1.3
Incising Factor	$C_{i,b} =$	1

Positive Bending (NDS 2018 2.3)

Adjusted Bending Strength - Positive Bending	$F_b^{'+} =$	1342 psi
--	--------------	----------

Negative Bending (NDS 2018 2.3)

Adjusted Bending Strength - Negative Bending	$F_b'^{-} =$	1342 psi
--	--------------	----------

Shear Design (NDS 2018 3.4)

Adjusted Shear Strength	$F_v' =$	207 psi
-------------------------	----------	---------

Bearing (NDS 2018 3.10)

Base Bearing Strength	$F_{c\perp}'/C_b =$	625 psi
-----------------------	---------------------	---------

Comments





<b>Client:</b> SIERRA JAMES CONSTRUCTION	<b>Author:</b> Allison Rymut	<b>Date:</b> Jan 30, 2026
<b>Project:</b> DESCHUTES BUNGALOW		<b>Job #:</b>
<b>Address:</b>		<b>Subject:</b> 1H3 (1 LEVEL BEAMS) <span style="border: 1px solid green; border-radius: 5px; padding: 2px;">PASS</span>
<b>References:</b> NDS 2018 (ASD)		

Summary

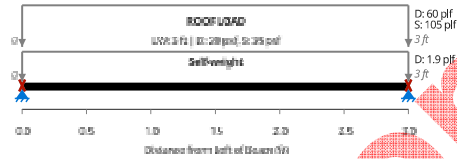

Member	2x6 D.Fir-L No. 2	
<span style="border: 1px solid green; border-radius: 5px; padding: 2px;">23%</span> Moment Utilization	$M/M' =$	188 lbft / 823 lbft
<span style="border: 1px solid green; border-radius: 5px; padding: 2px;">22%</span> Shear Utilization	$V/V' =$	250 lb / 1138 lb
<span style="border: 1px solid green; border-radius: 5px; padding: 2px;">9%</span> Bearing Utilization	$R/R' =$	250 lb / 2812 lb
Minimum Bearing Length (End Supports)	$\ell_{b,min,end} =$	0.267 in
<span style="border: 1px solid green; border-radius: 5px; padding: 2px;">4%</span> Governing Live / Short-Term Deflection	$\delta_{ST} =$	-0.00575 in (L/6260)

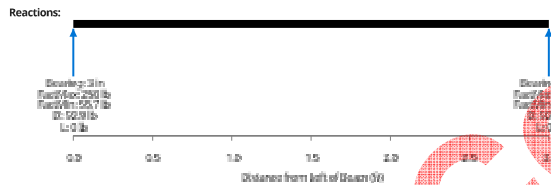

Key Properties

Beam Plan Length	$L_x =$	3 ft
Continuous Bracing for Lateral Torsional Buckling		No Continuous Bracing

Loads

Design Conditions

International Residential Code (IRC) 2021

Member Properties

Cross-Sectional Area	$A =$	8.25 in <sup>2</sup>
Strong Axis Moment of Inertia	$I_{xx} =$	20.8 in <sup>4</sup>
Section Modulus	$S =$	7.56 in <sup>3</sup>
Base Allowable Bending Stress	$F_b =$	900 psi
Base Allowable Shear Stress	$F_v =$	180 psi
Base Perpendicular Compression Allowable Stress	$F_{c\perp} =$	625 psi
True Modulus of Elasticity	$E_{true} =$	$1.60 \times 10^6$ psi
Apparent Modulus of Elasticity	$E_{app} =$	$1.60 \times 10^6$ psi
Modulus of Elasticity for Deflections	$E =$	$1.60 \times 10^6$ psi

Elastic Modulus (NDS 2018 2.3)

Adjusted Modulus of Elasticity	$E' =$	$1.60 \times 10^6$ psi
--------------------------------	--------	------------------------

Section Bending (NDS 2018 2.3)

Size Factor	$C_{F,b} =$	1.3
Incising Factor	$C_{i,b} =$	1

Positive Bending (NDS 2018 2.3)

Adjusted Bending Strength - Positive Bending	$F_b^{'+} =$	1306 psi
--	--------------	----------

Negative Bending (NDS 2018 2.3)

Adjusted Bending Strength - Negative Bending	$F_b'^{-} =$	1031 psi
--	--------------	----------

Shear Design (NDS 2018 3.4)

Adjusted Shear Strength	$F_v' =$	207 psi
-------------------------	----------	---------

Bearing (NDS 2018 3.10)

Base Bearing Strength	$F'_{c\perp}/C_b =$	625 psi
-----------------------	---------------------	---------

Comments

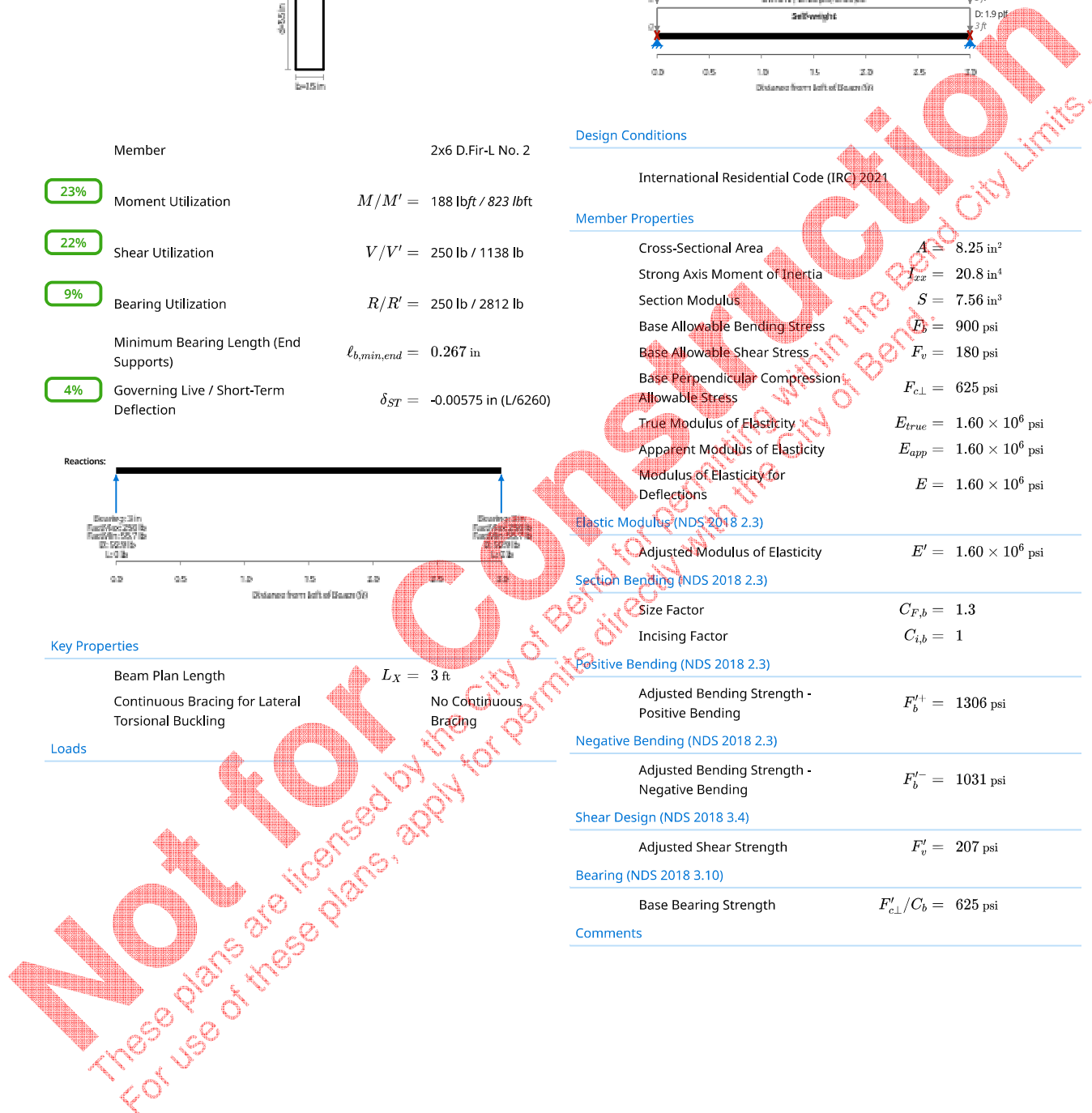



<b>Client:</b> SIERRA JAMES CONSTRUCTION	<b>Author:</b> Allison Rymut	<b>Date:</b> Jan 30, 2026
<b>Project:</b> DESCHUTES BUNGALOW		<b>Job #:</b>
<b>Address:</b>		<b>Subject:</b> 1H4 (1 LEVEL BEAMS) <span style="border: 1px solid green; border-radius: 5px; padding: 2px;">PASS</span>
<b>References:</b> NDS 2018 (ASD)		

Summary

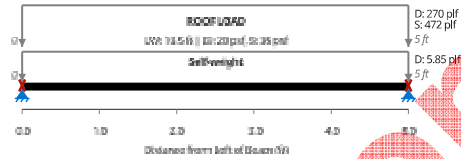

Member	4x8 D.Fir-L No. 2
<span style="border: 1px solid green; border-radius: 5px; padding: 2px;">69%</span> Moment Utilization	$M/M' = 2339 \text{ lbft} / 3409 \text{ lbft}$
<span style="border: 1px solid green; border-radius: 5px; padding: 2px;">53%</span> Shear Utilization	$V/V' = 1871 \text{ lb} / 3502 \text{ lb}$
<span style="border: 1px solid green; border-radius: 5px; padding: 2px;">29%</span> Bearing Utilization	$R/R' = 1871 \text{ lb} / 6562 \text{ lb}$
Minimum Bearing Length (End Supports)	$\ell_{b,min,end} = 0.855 \text{ in}$
<span style="border: 1px solid green; border-radius: 5px; padding: 2px;">15%</span> Governing Live / Short-Term Deflection	$\delta_{ST} = -0.0374 \text{ in} (L/1606)$

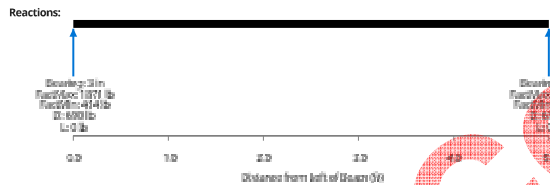

Design Conditions

International Residential Code (IRC) 2021

Member Properties

Cross-Sectional Area	$A = 25.4 \text{ in}^2$
Strong Axis Moment of Inertia	$I_{xx} = 111 \text{ in}^4$
Section Modulus	$S = 30.7 \text{ in}^3$
Base Allowable Bending Stress	$F_b = 900 \text{ psi}$
Base Allowable Shear Stress	$F_v = 180 \text{ psi}$
Base Perpendicular Compression Allowable Stress	$F_{c\perp} = 625 \text{ psi}$
True Modulus of Elasticity	$E_{true} = 1.60 \times 10^6 \text{ psi}$
Apparent Modulus of Elasticity	$E_{app} = 1.60 \times 10^6 \text{ psi}$
Modulus of Elasticity for Deflections	$E = 1.60 \times 10^6 \text{ psi}$

Elastic Modulus (NDS 2018 2.3)

Adjusted Modulus of Elasticity	$E' = 1.60 \times 10^6 \text{ psi}$
--------------------------------	-------------------------------------

Section Bending (NDS 2018 2.3)

Size Factor	$C_{F,b} = 1.3$
Incising Factor	$C_{i,b} = 1$

Positive Bending (NDS 2018 2.3)

Adjusted Bending Strength - Positive Bending	$F_b^{'+} = 1334 \text{ psi}$
--	-------------------------------

Negative Bending (NDS 2018 2.3)

Adjusted Bending Strength - Negative Bending	$F_b'^{-} = 1046 \text{ psi}$
--	-------------------------------

Shear Design (NDS 2018 3.4)

Adjusted Shear Strength	$F_v' = 207 \text{ psi}$
-------------------------	--------------------------

Bearing (NDS 2018 3.10)

Base Bearing Strength	$F_{c\perp}'/C_b = 625 \text{ psi}$
-----------------------	-------------------------------------

Comments

Key Properties

Beam Plan Length	$L_x = 5 \text{ ft}$
Continuous Bracing for Lateral Torsional Buckling	No Continuous Bracing

Loads

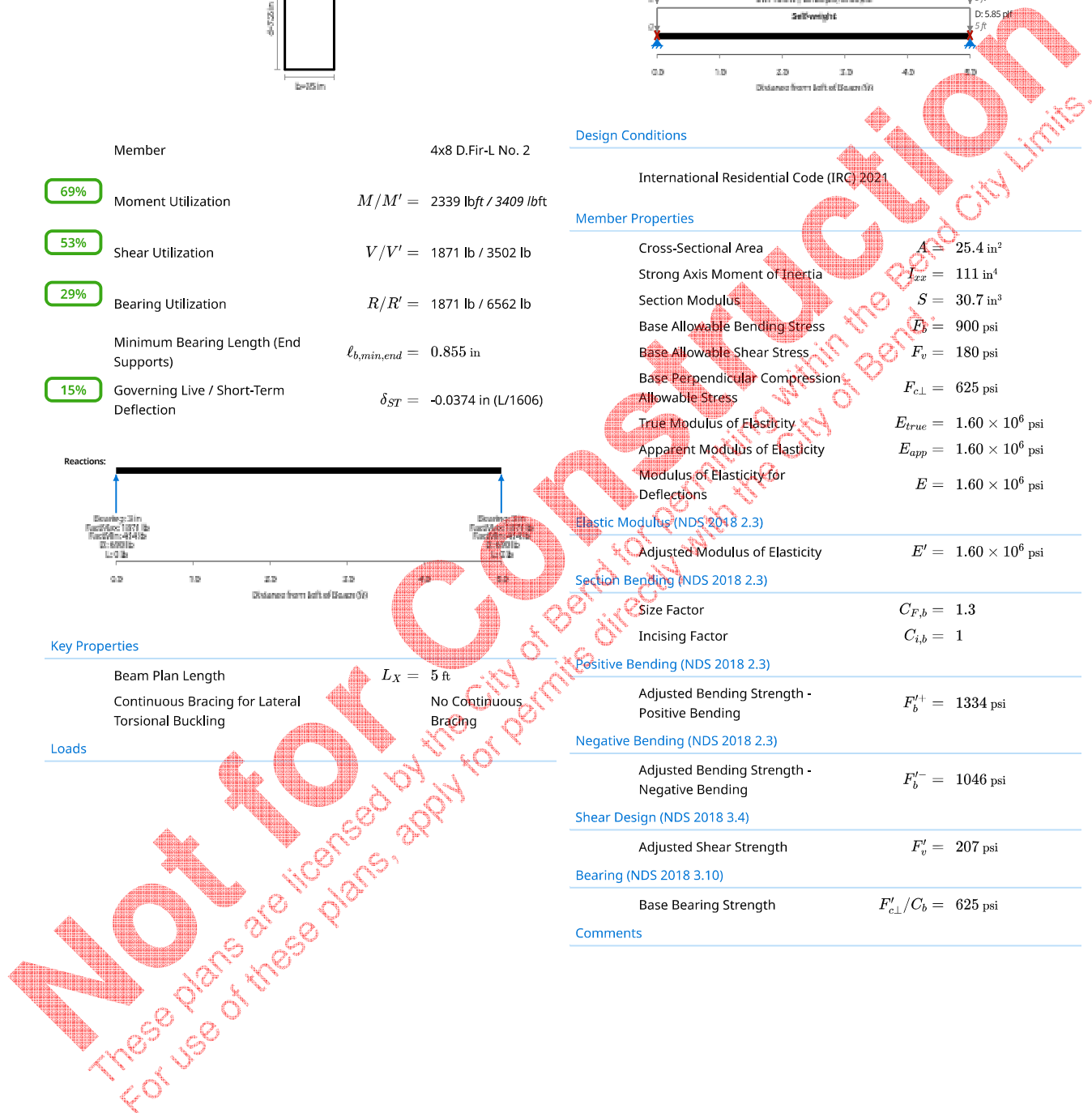



<b>Client:</b> SIERRA JAMES CONSTRUCTION	<b>Author:</b> Allison Rymut	<b>Date:</b> Jan 30, 2026
<b>Project:</b> DESCHUTES BUNGALOW		<b>Job #:</b>
<b>Address:</b>		<b>Subject:</b> 1H5 (1 LEVEL BEAMS) <span style="border: 1px solid green; border-radius: 5px; padding: 2px;">PASS</span>
<b>References:</b> NDS 2018 (ASD)		

Summary

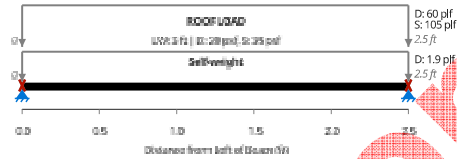
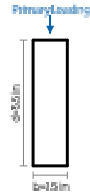

Member	2x6 D.Fir-L No. 2
<span style="border: 1px solid green; border-radius: 5px; padding: 2px;">16%</span> Moment Utilization	$M/M' = 130 \text{ lbft} / 827 \text{ lbft}$
<span style="border: 1px solid green; border-radius: 5px; padding: 2px;">18%</span> Shear Utilization	$V/V' = 209 \text{ lb} / 1138 \text{ lb}$
<span style="border: 1px solid green; border-radius: 5px; padding: 2px;">7%</span> Bearing Utilization	$R/R' = 209 \text{ lb} / 2812 \text{ lb}$
Minimum Bearing Length (End Supports)	$\ell_{b,min,end} = 0.223 \text{ in}$
<span style="border: 1px solid green; border-radius: 5px; padding: 2px;">2%</span> Governing Live / Short-Term Deflection	$\delta_{ST} = -0.00277 \text{ in} (L/10818)$

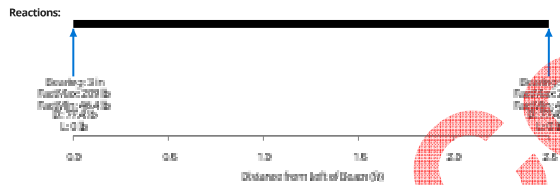

Key Properties

Beam Plan Length	$L_X = 2.5 \text{ ft}$
Continuous Bracing for Lateral Torsional Buckling	No Continuous Bracing
Loads	

Design Conditions

International Residential Code (IRC) 2021

Member Properties

Cross-Sectional Area	$A = 8.25 \text{ in}^2$
Strong Axis Moment of Inertia	$I_{xx} = 20.8 \text{ in}^4$
Section Modulus	$S = 7.56 \text{ in}^3$
Base Allowable Bending Stress	$F_b = 900 \text{ psi}$
Base Allowable Shear Stress	$F_v = 180 \text{ psi}$
Base Perpendicular Compression Allowable Stress	$F_{c\perp} = 625 \text{ psi}$
True Modulus of Elasticity	$E_{true} = 1.60 \times 10^6 \text{ psi}$
Apparent Modulus of Elasticity	$E_{app} = 1.60 \times 10^6 \text{ psi}$
Modulus of Elasticity for Deflections	$E = 1.60 \times 10^6 \text{ psi}$

Elastic Modulus (NDS 2018 2.3)

Adjusted Modulus of Elasticity	$E' = 1.60 \times 10^6 \text{ psi}$
--------------------------------	-------------------------------------

Section Bending (NDS 2018 2.3)

Size Factor	$C_{F,b} = 1.3$
Incising Factor	$C_{i,b} = 1$

Positive Bending (NDS 2018 2.3)

Adjusted Bending Strength - Positive Bending	$F_b^{'+} = 1313 \text{ psi}$
--	-------------------------------

Negative Bending (NDS 2018 2.3)

Adjusted Bending Strength - Negative Bending	$F_b'^{-} = 1034 \text{ psi}$
--	-------------------------------

Shear Design (NDS 2018 3.4)

Adjusted Shear Strength	$F_v' = 207 \text{ psi}$
-------------------------	--------------------------

Bearing (NDS 2018 3.10)

Base Bearing Strength	$F_{c\perp}'/C_b = 625 \text{ psi}$
-----------------------	-------------------------------------

Comments

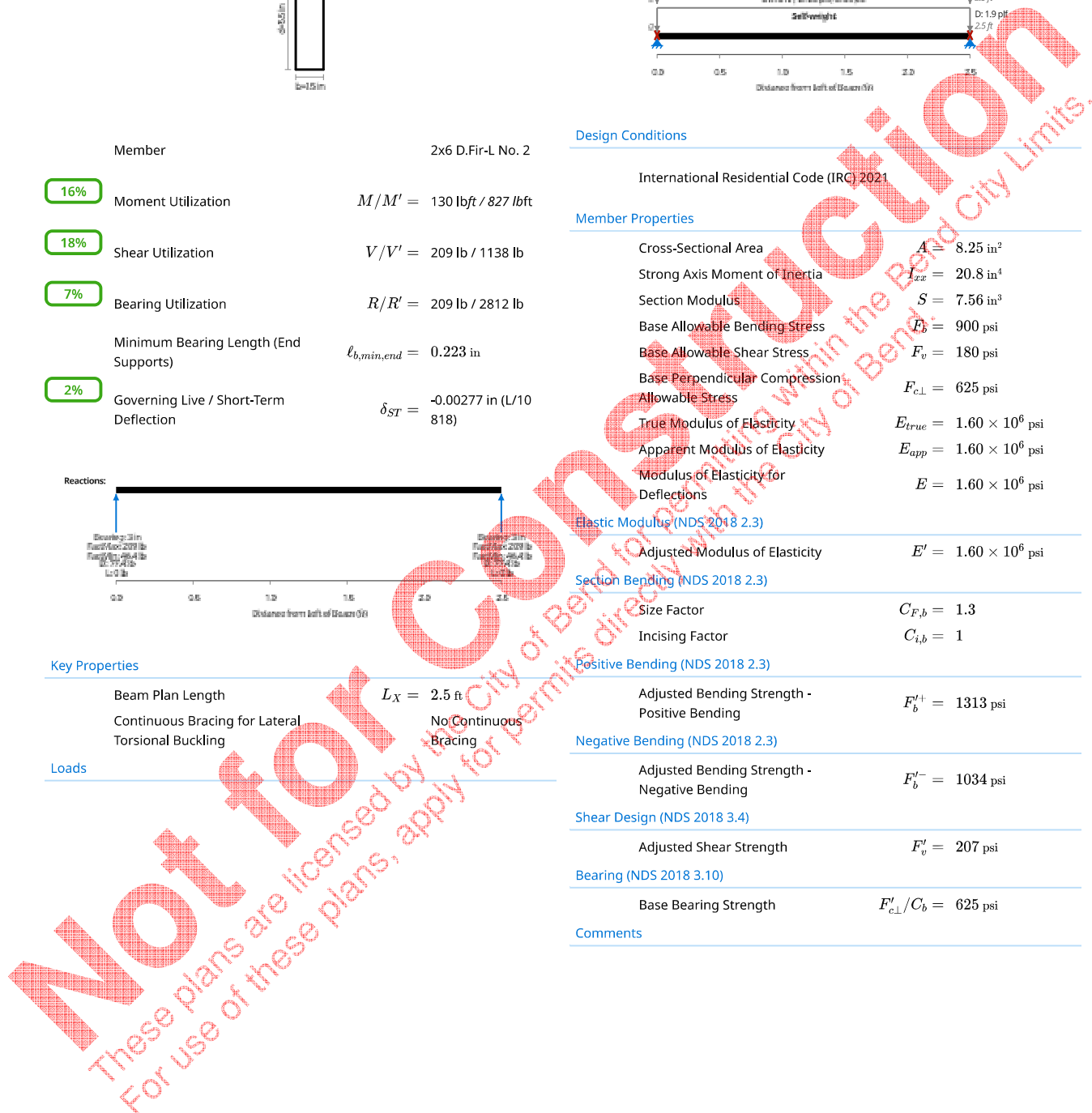



<b>Client:</b> SIERRA JAMES CONSTRUCTION	<b>Author:</b> Allison Rymut	<b>Date:</b> Jan 30, 2026
<b>Project:</b> DESCHUTES BUNGALOW		<b>Job #:</b>
<b>Address:</b>		<b>Subject:</b> 1H6 (1 LEVEL BEAMS) <span style="border: 1px solid green; border-radius: 5px; padding: 2px;">PASS</span>
<b>References:</b> NDS 2018 (ASD)		

Summary

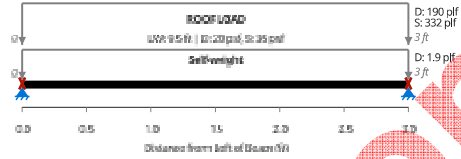

Member	2x6 D.Fir-L No. 2
<span style="border: 1px solid green; border-radius: 5px; padding: 2px;">72%</span> Moment Utilization	$M/M' = 590 \text{ lbft} / 823 \text{ lbft}$
<span style="border: 1px solid green; border-radius: 5px; padding: 2px;">69%</span> Shear Utilization	$V/V' = 787 \text{ lb} / 1138 \text{ lb}$
<span style="border: 1px solid green; border-radius: 5px; padding: 2px;">28%</span> Bearing Utilization	$R/R' = 787 \text{ lb} / 2812 \text{ lb}$
Minimum Bearing Length (End Supports)	$\ell_{b,min,end} = 0.839 \text{ in}$
<span style="border: 1px solid green; border-radius: 5px; padding: 2px;">12%</span> Governing Live / Short-Term Deflection	$\delta_{ST} = -0.0182 \text{ in} (L/1977)$

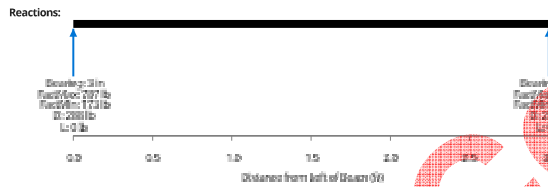

Key Properties

Beam Plan Length	$L_x = 3 \text{ ft}$
Continuous Bracing for Lateral Torsional Buckling	No Continuous Bracing

Loads

Design Conditions

International Residential Code (IRC) 2021

Member Properties

Cross-Sectional Area	$A = 8.25 \text{ in}^2$
Strong Axis Moment of Inertia	$I_{xx} = 20.8 \text{ in}^4$
Section Modulus	$S = 7.56 \text{ in}^3$
Base Allowable Bending Stress	$F_b = 900 \text{ psi}$
Base Allowable Shear Stress	$F_v = 180 \text{ psi}$
Base Perpendicular Compression Allowable Stress	$F_{c\perp} = 625 \text{ psi}$
True Modulus of Elasticity	$E_{true} = 1.60 \times 10^6 \text{ psi}$
Apparent Modulus of Elasticity	$E_{app} = 1.60 \times 10^6 \text{ psi}$
Modulus of Elasticity for Deflections	$E = 1.60 \times 10^6 \text{ psi}$

Elastic Modulus (NDS 2018 2.3)

Adjusted Modulus of Elasticity	$E' = 1.60 \times 10^6 \text{ psi}$
--------------------------------	-------------------------------------

Section Bending (NDS 2018 2.3)

Size Factor	$C_{F,b} = 1.3$
Incising Factor	$C_{i,b} = 1$

Positive Bending (NDS 2018 2.3)

Adjusted Bending Strength - Positive Bending	$F_b^{'+} = 1306 \text{ psi}$
--	-------------------------------

Negative Bending (NDS 2018 2.3)

Adjusted Bending Strength - Negative Bending	$F_b'^{-} = 1031 \text{ psi}$
--	-------------------------------

Shear Design (NDS 2018 3.4)

Adjusted Shear Strength	$F_v' = 207 \text{ psi}$
-------------------------	--------------------------

Bearing (NDS 2018 3.10)

Base Bearing Strength	$F_{c\perp}'/C_b = 625 \text{ psi}$
-----------------------	-------------------------------------

Comments

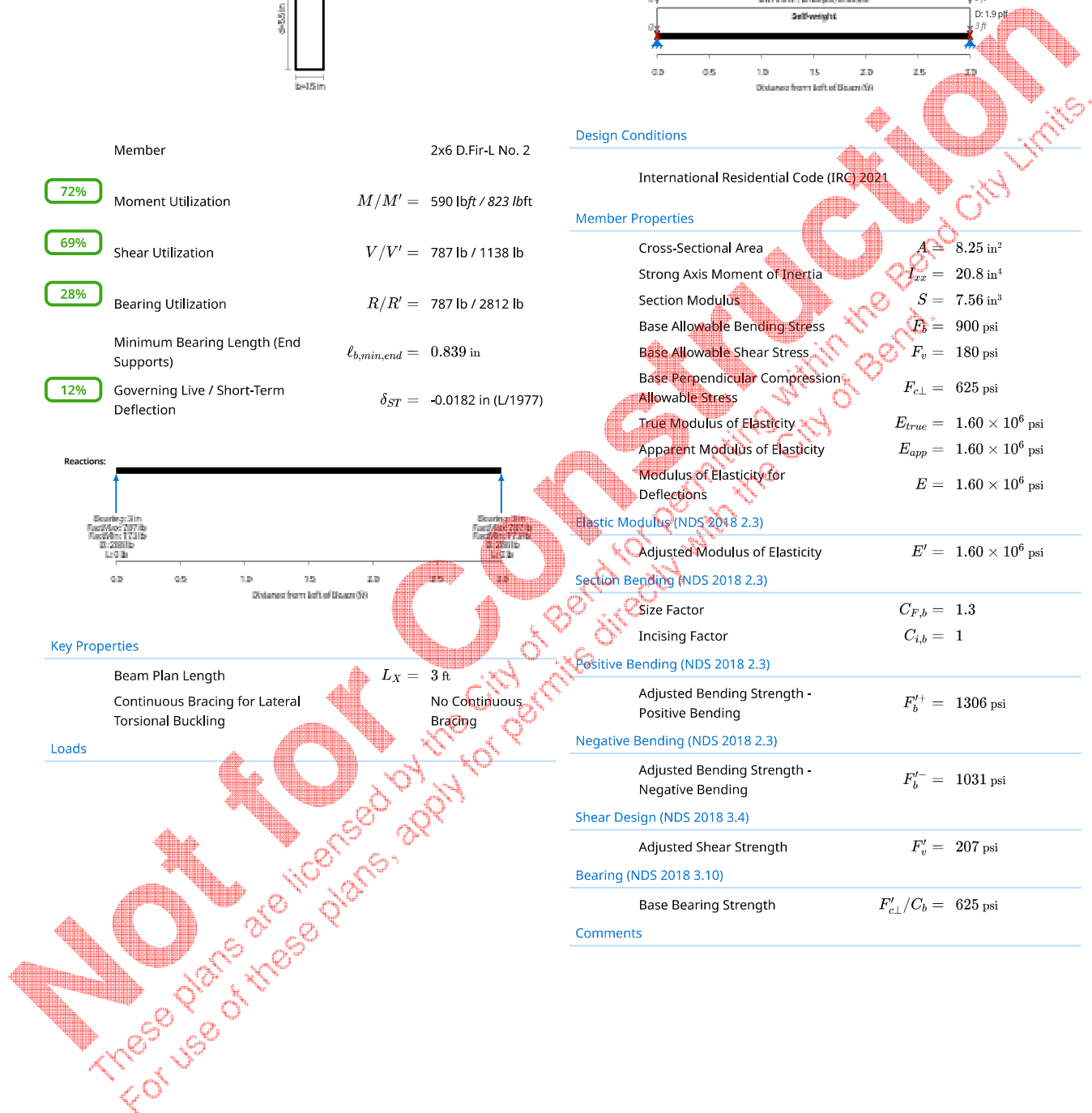



<b>Client:</b> SIERRA JAMES CONSTRUCTION	<b>Author:</b> Allison Rymut	<b>Date:</b> Jan 30, 2026
<b>Project:</b> DESCHUTES BUNGALOW		<b>Job #:</b>
<b>Address:</b>		<b>Subject:</b> 1H7 (1 LEVEL BEAMS) <span style="border: 1px solid green; border-radius: 5px; padding: 2px;">PASS</span>
<b>References:</b> NDS 2018 (ASD)		

Summary

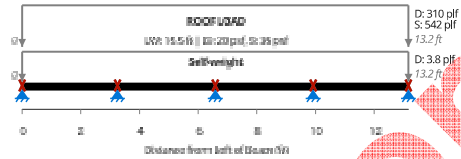
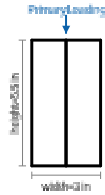

Member	2 plies - 2x6 D.Fir-L No. 2	
<span style="border: 1px solid green; border-radius: 5px; padding: 2px;">58%</span> Moment Utilization	$M/M' =$	-984 lbft / 1690 lbft
<span style="border: 1px solid green; border-radius: 5px; padding: 2px;">74%</span> Shear Utilization	$V/V' =$	1694 lb / 2277 lb
<span style="border: 1px solid green; border-radius: 5px; padding: 2px;">51%</span> Bearing Utilization	$R/R' =$	3208 lb / 6328 lb
Minimum Bearing Length (End Supports)	$\ell_{b,min,end} =$	0.581 in
Minimum Bearing Length (Int Supports)	$\ell_{b,min,int} =$	1.52 in
<span style="border: 1px solid green; border-radius: 5px; padding: 2px;">6%</span> Governing Live / Short-Term Deflection	$\delta_{ST} =$	-0.00999 in (L/3902)

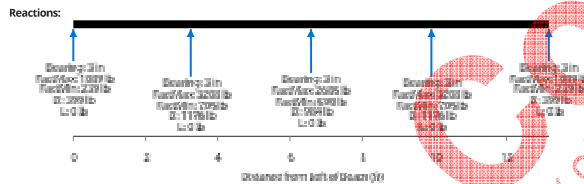

Key Properties

Beam Plan Length	$L_x =$	13.2 ft
Continuous Bracing for Lateral Torsional Buckling		No Continuous Bracing

Loads

Design Conditions

International Residential Code (IRC) 2021

Member Properties

Cross-Sectional Area	$A =$	16.5 in <sup>2</sup>
Strong Axis Moment of Inertia	$I_{xx} =$	41.6 in <sup>4</sup>
Section Modulus	$S =$	15.1 in <sup>3</sup>
Base Allowable Bending Stress	$F_b =$	900 psi
Base Allowable Shear Stress	$F_v =$	180 psi
Base Perpendicular Compression Allowable Stress	$F_{c\perp} =$	625 psi
True Modulus of Elasticity	$E_{true} =$	$1.60 \times 10^6$ psi
Apparent Modulus of Elasticity	$E_{app} =$	$1.60 \times 10^6$ psi
Modulus of Elasticity for Deflections	$E =$	$1.60 \times 10^6$ psi

Elastic Modulus (NDS 2018 2.3)

Adjusted Modulus of Elasticity	$E' =$	$1.60 \times 10^6$ psi
--------------------------------	--------	------------------------

Section Bending (NDS 2018 2.3)

Size Factor	$C_{F,b} =$	1.3
Incising Factor	$C_{i,b} =$	1

Positive Bending (NDS 2018 2.3)

Adjusted Bending Strength - Positive Bending	$F_b^{'+} =$	1341 psi
--	--------------	----------

Negative Bending (NDS 2018 2.3)

Adjusted Bending Strength - Negative Bending	$F_b'^{-} =$	1341 psi
--	--------------	----------

Shear Design (NDS 2018 3.4)

Adjusted Shear Strength	$F_v' =$	207 psi
-------------------------	----------	---------

Bearing (NDS 2018 3.10)

Base Bearing Strength	$F_{c\perp}'/C_b =$	625 psi
-----------------------	---------------------	---------

Comments

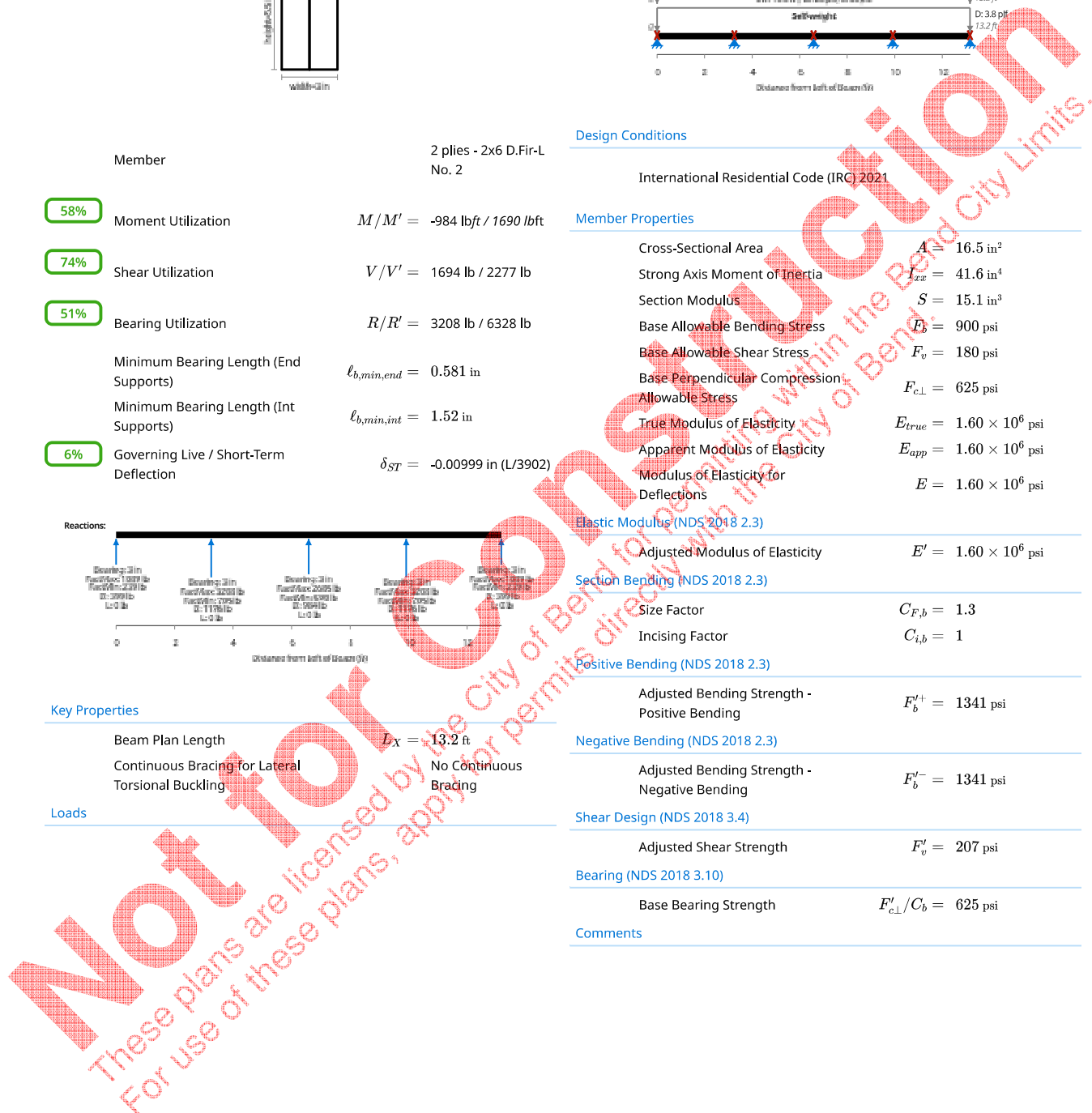



<b>Client:</b> SIERRA JAMES CONSTRUCTION	<b>Author:</b> Allison Rymut	<b>Date:</b> Jan 30, 2026
<b>Project:</b> DESCHUTES BUNGALOW		<b>Job #:</b>
<b>Address:</b>		<b>Subject:</b> 1H8 (1 LEVEL BEAMS) <span style="border: 1px solid green; border-radius: 5px; padding: 2px;">PASS</span>
<b>References:</b> NDS 2018 (ASD)		

Summary

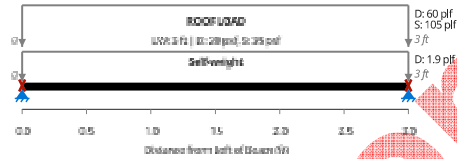
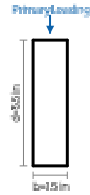

Member	2x6 D.Fir-L No. 2
<span style="border: 1px solid green; border-radius: 5px; padding: 2px;">23%</span> Moment Utilization	$M/M' = 188 \text{ lbft} / 823 \text{ lbft}$
<span style="border: 1px solid green; border-radius: 5px; padding: 2px;">22%</span> Shear Utilization	$V/V' = 250 \text{ lb} / 1138 \text{ lb}$
<span style="border: 1px solid green; border-radius: 5px; padding: 2px;">9%</span> Bearing Utilization	$R/R' = 250 \text{ lb} / 2812 \text{ lb}$
Minimum Bearing Length (End Supports)	$\ell_{b,min,end} = 0.267 \text{ in}$
<span style="border: 1px solid green; border-radius: 5px; padding: 2px;">4%</span> Governing Live / Short-Term Deflection	$\delta_{ST} = -0.00575 \text{ in (L/6260)}$

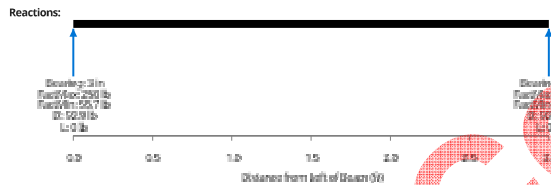

Key Properties

Beam Plan Length	$L_x = 3 \text{ ft}$
Continuous Bracing for Lateral Torsional Buckling	No Continuous Bracing

Loads

Design Conditions

International Residential Code (IRC) 2021

Member Properties

Cross-Sectional Area	$A = 8.25 \text{ in}^2$
Strong Axis Moment of Inertia	$I_{xx} = 20.8 \text{ in}^4$
Section Modulus	$S = 7.56 \text{ in}^3$
Base Allowable Bending Stress	$F_b = 900 \text{ psi}$
Base Allowable Shear Stress	$F_v = 180 \text{ psi}$
Base Perpendicular Compression Allowable Stress	$F_{c\perp} = 625 \text{ psi}$
True Modulus of Elasticity	$E_{true} = 1.60 \times 10^6 \text{ psi}$
Apparent Modulus of Elasticity	$E_{app} = 1.60 \times 10^6 \text{ psi}$
Modulus of Elasticity for Deflections	$E = 1.60 \times 10^6 \text{ psi}$

Elastic Modulus (NDS 2018 2.3)

Adjusted Modulus of Elasticity	$E' = 1.60 \times 10^6 \text{ psi}$
--------------------------------	-------------------------------------

Section Bending (NDS 2018 2.3)

Size Factor	$C_{F,b} = 1.3$
Incising Factor	$C_{i,b} = 1$

Positive Bending (NDS 2018 2.3)

Adjusted Bending Strength - Positive Bending	$F_b^{'+} = 1306 \text{ psi}$
--	-------------------------------

Negative Bending (NDS 2018 2.3)

Adjusted Bending Strength - Negative Bending	$F_b'^{-} = 1031 \text{ psi}$
--	-------------------------------

Shear Design (NDS 2018 3.4)

Adjusted Shear Strength	$F_v' = 207 \text{ psi}$
-------------------------	--------------------------

Bearing (NDS 2018 3.10)

Base Bearing Strength	$F'_{c\perp}/C_b = 625 \text{ psi}$
-----------------------	-------------------------------------

Comments

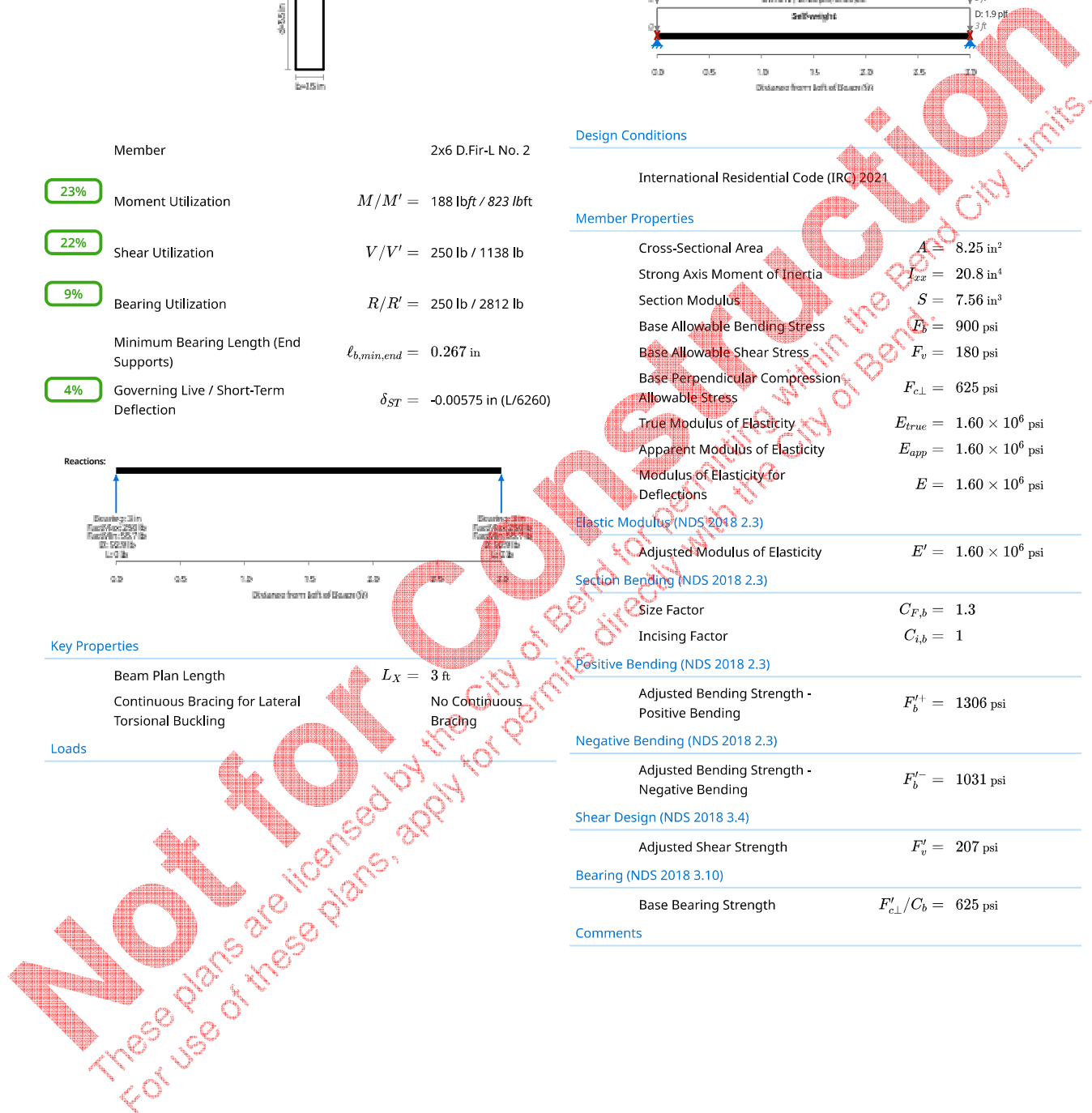



<b>Client:</b> SIERRA JAMES CONSTRUCTION	<b>Author:</b> Allison Rymut	<b>Date:</b> Jan 30, 2026
<b>Project:</b> DESCHUTES BUNGALOW		<b>Job #:</b>
<b>Address:</b>		<b>Subject:</b> 1H9 (1 LEVEL BEAMS) <span style="border: 1px solid green; border-radius: 5px; padding: 2px;">PASS</span>
<b>References:</b> NDS 2018 (ASD)		

Summary

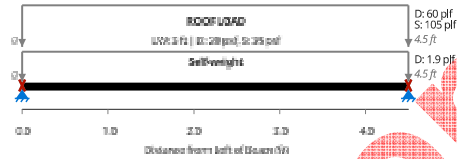
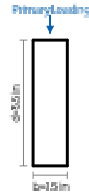

Member	2x6 D.Fir-L No. 2
<span style="border: 1px solid green; border-radius: 5px; padding: 2px;">52%</span> Moment Utilization	$M/M' = 422 \text{ lbft} / 808 \text{ lbft}$
<span style="border: 1px solid green; border-radius: 5px; padding: 2px;">33%</span> Shear Utilization	$V/V' = 376 \text{ lb} / 1138 \text{ lb}$
<span style="border: 1px solid green; border-radius: 5px; padding: 2px;">13%</span> Bearing Utilization	$R/R' = 376 \text{ lb} / 2812 \text{ lb}$
Minimum Bearing Length (End Supports)	$\ell_{b,min,end} = 0.401 \text{ in}$
<span style="border: 1px solid green; border-radius: 5px; padding: 2px;">13%</span> Governing Live / Short-Term Deflection	$\delta_{ST} = -0.0291 \text{ in (L/1855)}$

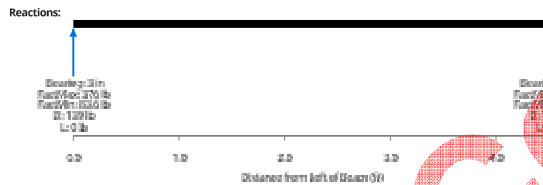

Key Properties

Beam Plan Length	$L_x = 4.5 \text{ ft}$
Continuous Bracing for Lateral Torsional Buckling	No Continuous Bracing

Loads

Design Conditions

International Residential Code (IRC) 2021

Member Properties

Cross-Sectional Area	$A = 8.25 \text{ in}^2$
Strong Axis Moment of Inertia	$I_{xx} = 20.8 \text{ in}^4$
Section Modulus	$S = 7.56 \text{ in}^3$
Base Allowable Bending Stress	$F_b = 900 \text{ psi}$
Base Allowable Shear Stress	$F_v = 180 \text{ psi}$
Base Perpendicular Compression Allowable Stress	$F_{c\perp} = 625 \text{ psi}$
True Modulus of Elasticity	$E_{true} = 1.60 \times 10^6 \text{ psi}$
Apparent Modulus of Elasticity	$E_{app} = 1.60 \times 10^6 \text{ psi}$
Modulus of Elasticity for Deflections	$E = 1.60 \times 10^6 \text{ psi}$

Elastic Modulus (NDS 2018 2.3)

Adjusted Modulus of Elasticity	$E' = 1.60 \times 10^6 \text{ psi}$
--------------------------------	-------------------------------------

Section Bending (NDS 2018 2.3)

Size Factor	$C_{F,b} = 1.3$
Incising Factor	$C_{i,b} = 1$

Positive Bending (NDS 2018 2.3)

Adjusted Bending Strength - Positive Bending	$F_b^{'+} = 1283 \text{ psi}$
--	-------------------------------

Negative Bending (NDS 2018 2.3)

Adjusted Bending Strength - Negative Bending	$F_b'^{-} = 1020 \text{ psi}$
--	-------------------------------

Shear Design (NDS 2018 3.4)

Adjusted Shear Strength	$F_v' = 207 \text{ psi}$
-------------------------	--------------------------

Bearing (NDS 2018 3.10)

Base Bearing Strength	$F_{c\perp}'/C_b = 625 \text{ psi}$
-----------------------	-------------------------------------

Comments

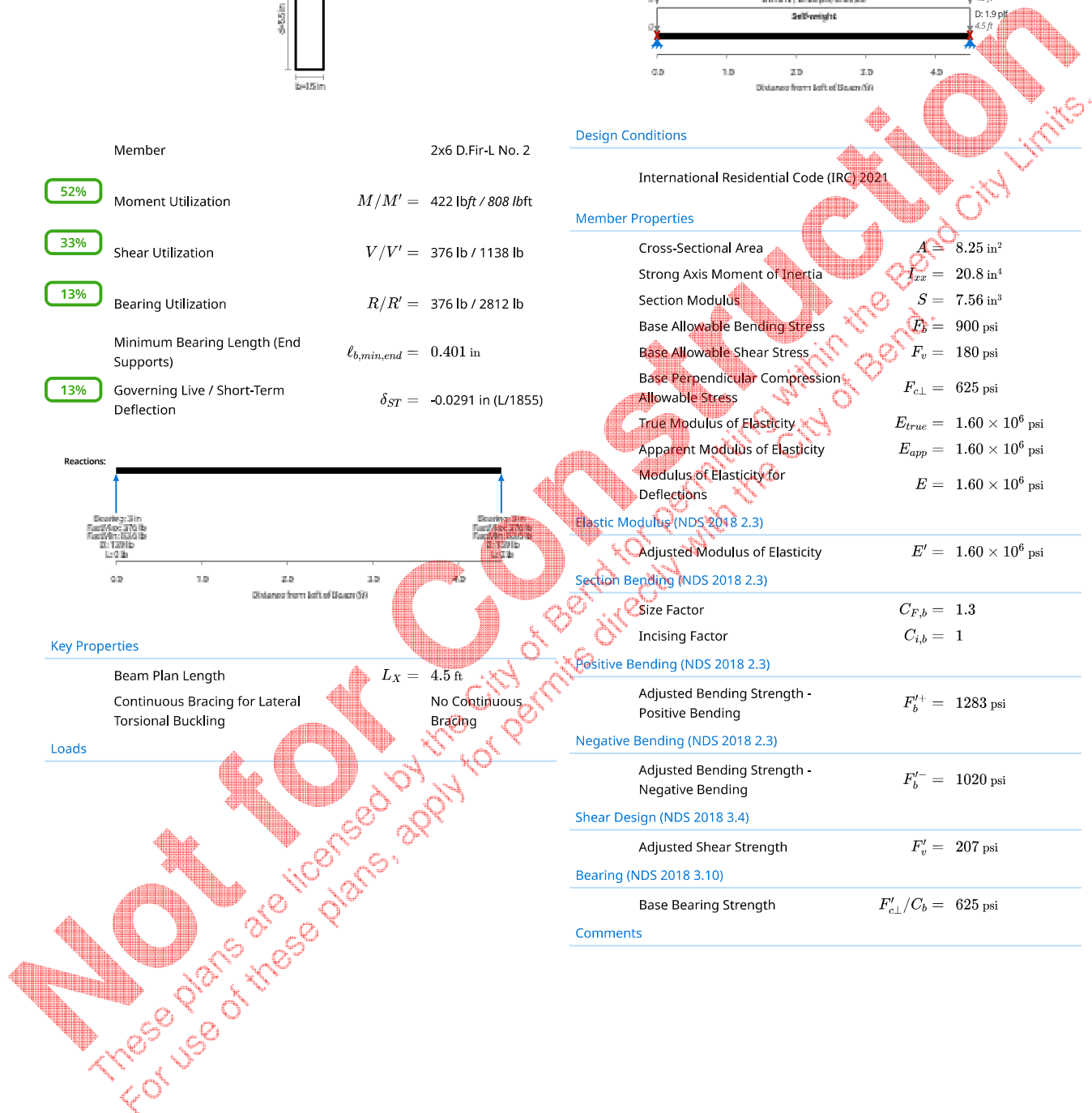



<b>Client:</b> SIERRA JAMES CONSTRUCTION	<b>Author:</b> Allison Rymut	<b>Date:</b> Jan 30, 2026
<b>Project:</b> DESCHUTES BUNGALOW		<b>Job #:</b>
<b>Address:</b>	<b>Subject:</b> 1H10 (1 LEVEL BEAMS) <span style="border: 1px solid green; border-radius: 5px; padding: 2px;">PASS</span>	
<b>References:</b> NDS 2018 (ASD)		

Summary

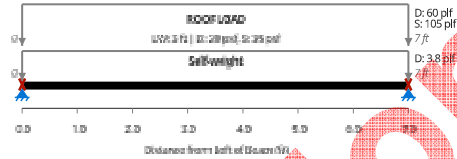
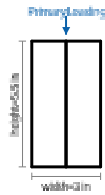

Member	2 plies - 2x6 D,Fir-L No. 2
<span style="border: 1px solid green; border-radius: 5px; padding: 2px;">62%</span> Moment Utilization	$M/M' = 1034 \text{ lbft} / 1677 \text{ lbft}$
<span style="border: 1px solid green; border-radius: 5px; padding: 2px;">26%</span> Shear Utilization	$V/V' = 591 \text{ lb} / 2277 \text{ lb}$
<span style="border: 1px solid green; border-radius: 5px; padding: 2px;">11%</span> Bearing Utilization	$R/R' = 591 \text{ lb} / 5625 \text{ lb}$
Minimum Bearing Length (End Supports)	$\ell_{b,min,end} = 0.315 \text{ in}$
<span style="border: 1px solid green; border-radius: 5px; padding: 2px;">24%</span> Governing Live / Short-Term Deflection	$\delta_{ST} = -0.0852 \text{ in} (L/986)$

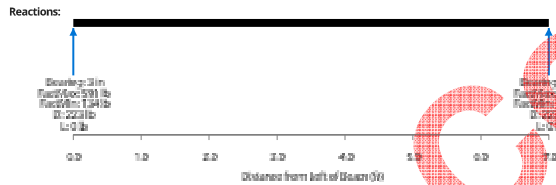

Key Properties

Beam Plan Length	$L_x = 7 \text{ ft}$
Continuous Bracing for Lateral Torsional Buckling	No Continuous Bracing

Loads

Design Conditions

International Residential Code (IRC) 2021

Member Properties

Cross-Sectional Area	$A = 16.5 \text{ in}^2$
Strong Axis Moment of Inertia	$I_{xx} = 41.6 \text{ in}^4$
Section Modulus	$S = 15.1 \text{ in}^3$
Base Allowable Bending Stress	$F_b = 900 \text{ psi}$
Base Allowable Shear Stress	$F_v = 180 \text{ psi}$
Base Perpendicular Compression Allowable Stress	$F_{c,\perp} = 625 \text{ psi}$
True Modulus of Elasticity	$E_{true} = 1.60 \times 10^6 \text{ psi}$
Apparent Modulus of Elasticity	$E_{app} = 1.60 \times 10^6 \text{ psi}$
Modulus of Elasticity for Deflections	$E = 1.60 \times 10^6 \text{ psi}$

Elastic Modulus (NDS 2018 2.3)

Adjusted Modulus of Elasticity	$E' = 1.60 \times 10^6 \text{ psi}$
--------------------------------	-------------------------------------

Section Bending (NDS 2018 2.3)

Size Factor	$C_{F,b} = 1.3$
Incising Factor	$C_{i,b} = 1$

Positive Bending (NDS 2018 2.3)

Adjusted Bending Strength - Positive Bending	$F_b^{'+} = 1330 \text{ psi}$
--	-------------------------------

Negative Bending (NDS 2018 2.3)

Adjusted Bending Strength - Negative Bending	$F_b^{'-} = 1044 \text{ psi}$
--	-------------------------------

Shear Design (NDS 2018 3.4)

Adjusted Shear Strength	$F_v^i = 207 \text{ psi}$
-------------------------	---------------------------

Bearing (NDS 2018 3.10)

Base Bearing Strength	$F'_{c,\perp} / C_b = 625 \text{ psi}$
-----------------------	--

Comments

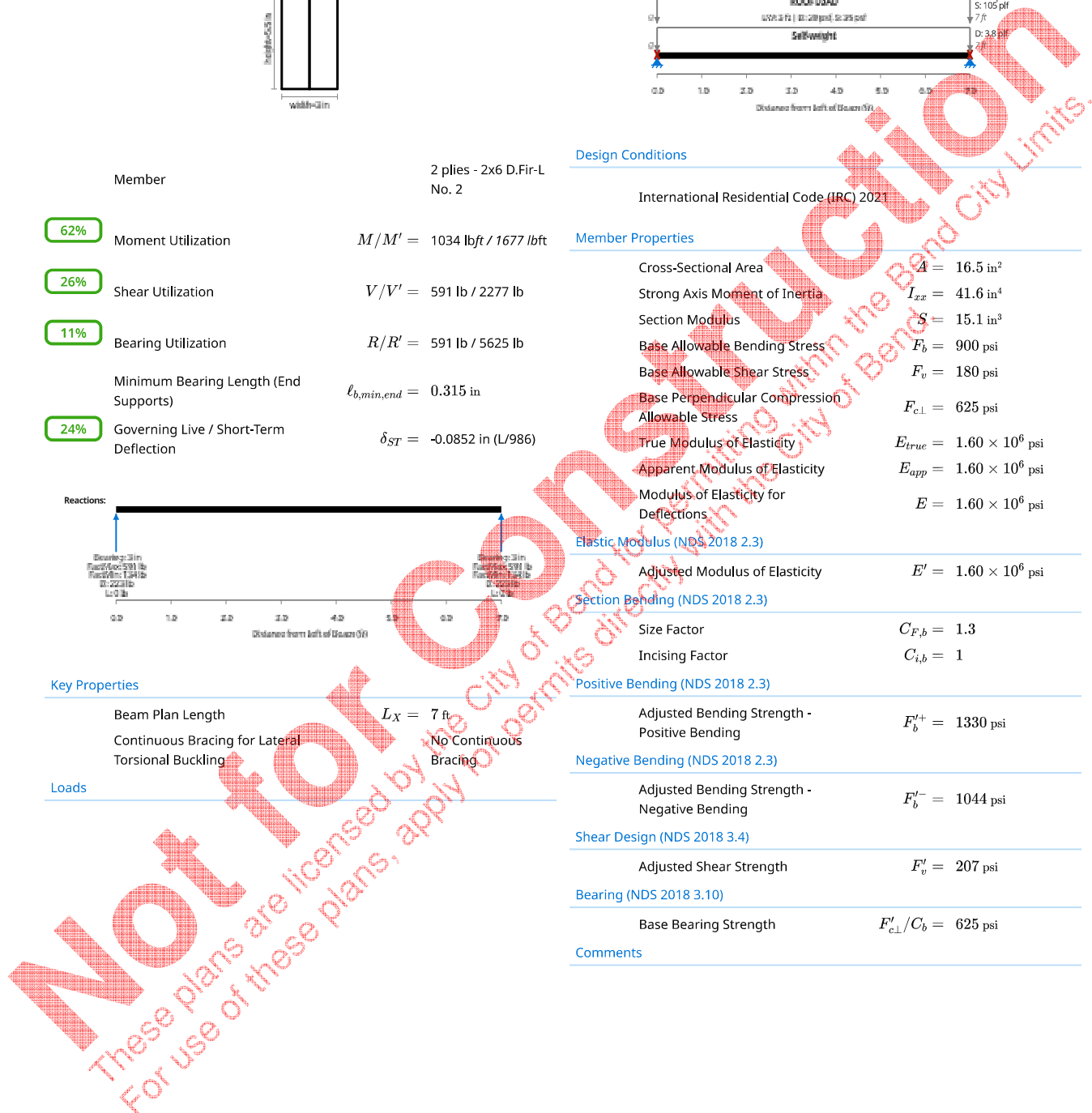



<b>Client:</b> SIERRA JAMES CONSTRUCTION	<b>Author:</b> Allison Rymut	<b>Date:</b> Jan 30, 2026
<b>Project:</b> DESCHUTES BUNGALOW		<b>Job #:</b>
<b>Address:</b>		<b>Subject:</b> 1RB1 (1 LEVEL BEAMS) <span style="border: 1px solid green; border-radius: 5px; padding: 2px;">PASS</span>
<b>References:</b> NDS 2018 (ASD)		

Summary

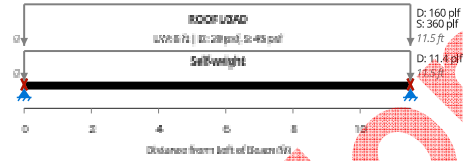

Member	5-1/2x9 24F-V4 DF
<span style="border: 1px solid green; border-radius: 5px; padding: 2px;">52%</span> Moment Utilization	$M/M' = 8785 \text{ lbft} / 16887 \text{ lbft}$
<span style="border: 1px solid green; border-radius: 5px; padding: 2px;">30%</span> Shear Utilization	$V/V' = 3056 \text{ lb} / 10057 \text{ lb}$
<span style="border: 1px solid green; border-radius: 5px; padding: 2px;">28%</span> Bearing Utilization	$R/R' = 3056 \text{ lb} / 10725 \text{ lb}$
Minimum Bearing Length (End Supports)	$\ell_{b,min,end} = 0.855 \text{ in}$
<span style="border: 1px solid green; border-radius: 5px; padding: 2px;">41%</span> Governing Live / Short-Term Deflection	$\delta_{ST} = -0.236 \text{ in} (L/586)$

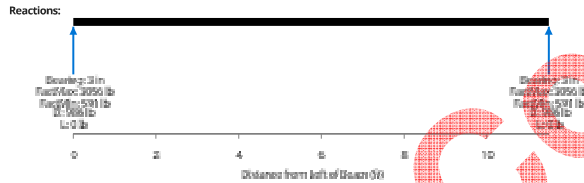

Key Properties

Beam Plan Length	$L_X = 11.5 \text{ ft}$
Continuous Bracing for Lateral Torsional Buckling	No Continuous Bracing

Loads

Design Conditions

International Residential Code (IRC) 2021

Member Properties

Cross-Sectional Area	$A = 49.5 \text{ in}^2$
Strong Axis Moment of Inertia	$I_{xx} = 334 \text{ in}^4$
Section Modulus	$S = 74.3 \text{ in}^3$
Base Allowable Bending Stress	$F_b = 2400 \text{ psi}$
Base Allowable Shear Stress	$F_v = 265 \text{ psi}$
Base Perpendicular Compression Allowable Stress	$F_{c\perp} = 650 \text{ psi}$
True Modulus of Elasticity	$E_{true} = 1.90 \times 10^6 \text{ psi}$
Apparent Modulus of Elasticity	$E_{app} = 1.80 \times 10^6 \text{ psi}$
Modulus of Elasticity for Deflections	$E = 1.80 \times 10^6 \text{ psi}$

Elastic Modulus (NDS 2018 2.3)

Adjusted Modulus of Elasticity	$E' = 1.80 \times 10^6 \text{ psi}$
--------------------------------	-------------------------------------

Section Bending (NDS 2018 2.3)

Volume Factor	$C_V = 1$
---------------	-----------

Positive Bending (NDS 2018 2.3)

Adjusted Bending Strength - Positive Bending	$F_b^{'+} = 2729 \text{ psi}$
--	-------------------------------

Negative Bending (NDS 2018 2.3)

Adjusted Bending Strength - Negative Bending	$F_b^{'-} = 1655 \text{ psi}$
--	-------------------------------

Shear Design (NDS 2018 3.4)

Adjusted Shear Strength	$F_v' = 305 \text{ psi}$
-------------------------	--------------------------

Bearing (NDS 2018 3.10)

Base Bearing Strength	$F'_{c\perp}/C_b = 650 \text{ psi}$
-----------------------	-------------------------------------

Comments

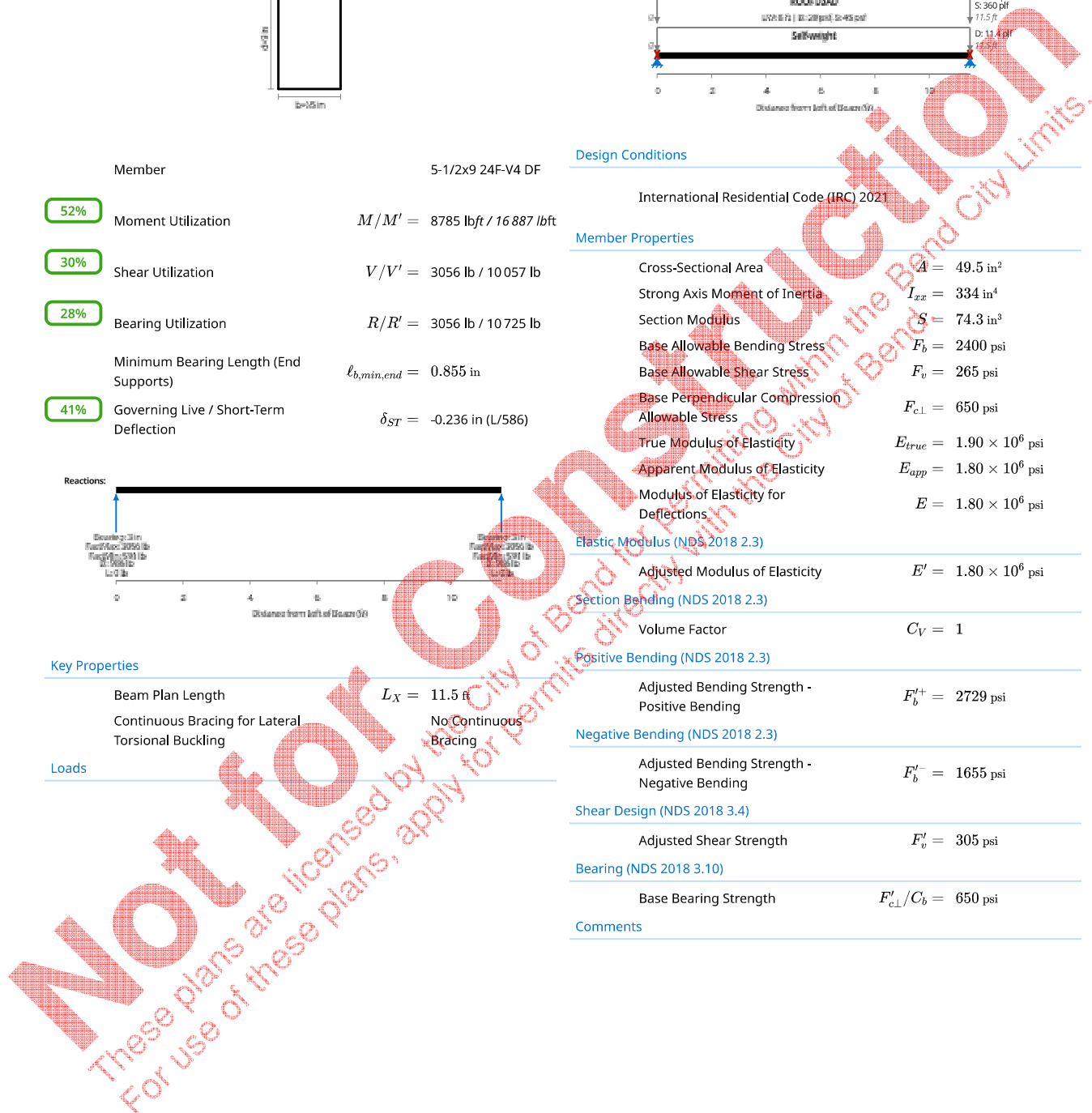



<b>Client:</b> SIERRA JAMES CONSTRUCTION	<b>Author:</b> Allison Rymut	<b>Date:</b> Jan 30, 2026
<b>Project:</b> DESCHUTES BUNGALOW		<b>Job #:</b>
<b>Address:</b>		<b>Subject:</b> 1RB2 (1 LEVEL BEAMS) <span style="border: 1px solid green; border-radius: 5px; padding: 2px;">PASS</span>
<b>References:</b> NDS 2018 (ASD)		

Summary

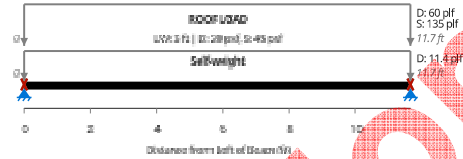

Member	5-1/2x9 24F-V4 DF
<span style="border: 1px solid green; border-radius: 5px; padding: 2px;">21%</span> Moment Utilization	$M/M' = 3514 \text{ lbft} / 16884 \text{ lbft}$
<span style="border: 1px solid green; border-radius: 5px; padding: 2px;">12%</span> Shear Utilization	$V/V' = 1204 \text{ lb} / 10057 \text{ lb}$
<span style="border: 1px solid green; border-radius: 5px; padding: 2px;">11%</span> Bearing Utilization	$R/R' = 1204 \text{ lb} / 10725 \text{ lb}$
Minimum Bearing Length (End Supports)	$\ell_{b,min,end} = 0.337 \text{ in}$
<span style="border: 1px solid green; border-radius: 5px; padding: 2px;">16%</span> Governing Live / Short-Term Deflection	$\delta_{ST} = -0.0937 \text{ in} (L/1495)$

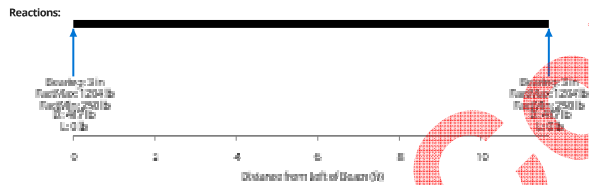

Key Properties

Beam Plan Length	$L_X = 11.7 \text{ ft}$
Continuous Bracing for Lateral Torsional Buckling	No Continuous Bracing

Loads

Design Conditions

International Residential Code (IRC) 2021

Member Properties

Cross-Sectional Area	$A = 49.5 \text{ in}^2$
Strong Axis Moment of Inertia	$I_{xx} = 334 \text{ in}^4$
Section Modulus	$S = 74.3 \text{ in}^3$
Base Allowable Bending Stress	$F_b = 2400 \text{ psi}$
Base Allowable Shear Stress	$F_v = 265 \text{ psi}$
Base Perpendicular Compression Allowable Stress	$F_{c\perp} = 650 \text{ psi}$
True Modulus of Elasticity	$E_{true} = 1.90 \times 10^6 \text{ psi}$
Apparent Modulus of Elasticity	$E_{app} = 1.80 \times 10^6 \text{ psi}$
Modulus of Elasticity for Deflections	$E = 1.80 \times 10^6 \text{ psi}$

Elastic Modulus (NDS 2018 2.3)

Adjusted Modulus of Elasticity	$E' = 1.80 \times 10^6 \text{ psi}$
--------------------------------	-------------------------------------

Section Bending (NDS 2018 2.3)

Volume Factor	$C_V = 1$
---------------	-----------

Positive Bending (NDS 2018 2.3)

Adjusted Bending Strength - Positive Bending	$F_b^{'+} = 2729 \text{ psi}$
--	-------------------------------

Negative Bending (NDS 2018 2.3)

Adjusted Bending Strength - Negative Bending	$F_b^{'-} = 1654 \text{ psi}$
--	-------------------------------

Shear Design (NDS 2018 3.4)

Adjusted Shear Strength	$F_v^I = 305 \text{ psi}$
-------------------------	---------------------------

Bearing (NDS 2018 3.10)

Base Bearing Strength	$F'_{c\perp}/C_b = 650 \text{ psi}$
-----------------------	-------------------------------------

Comments

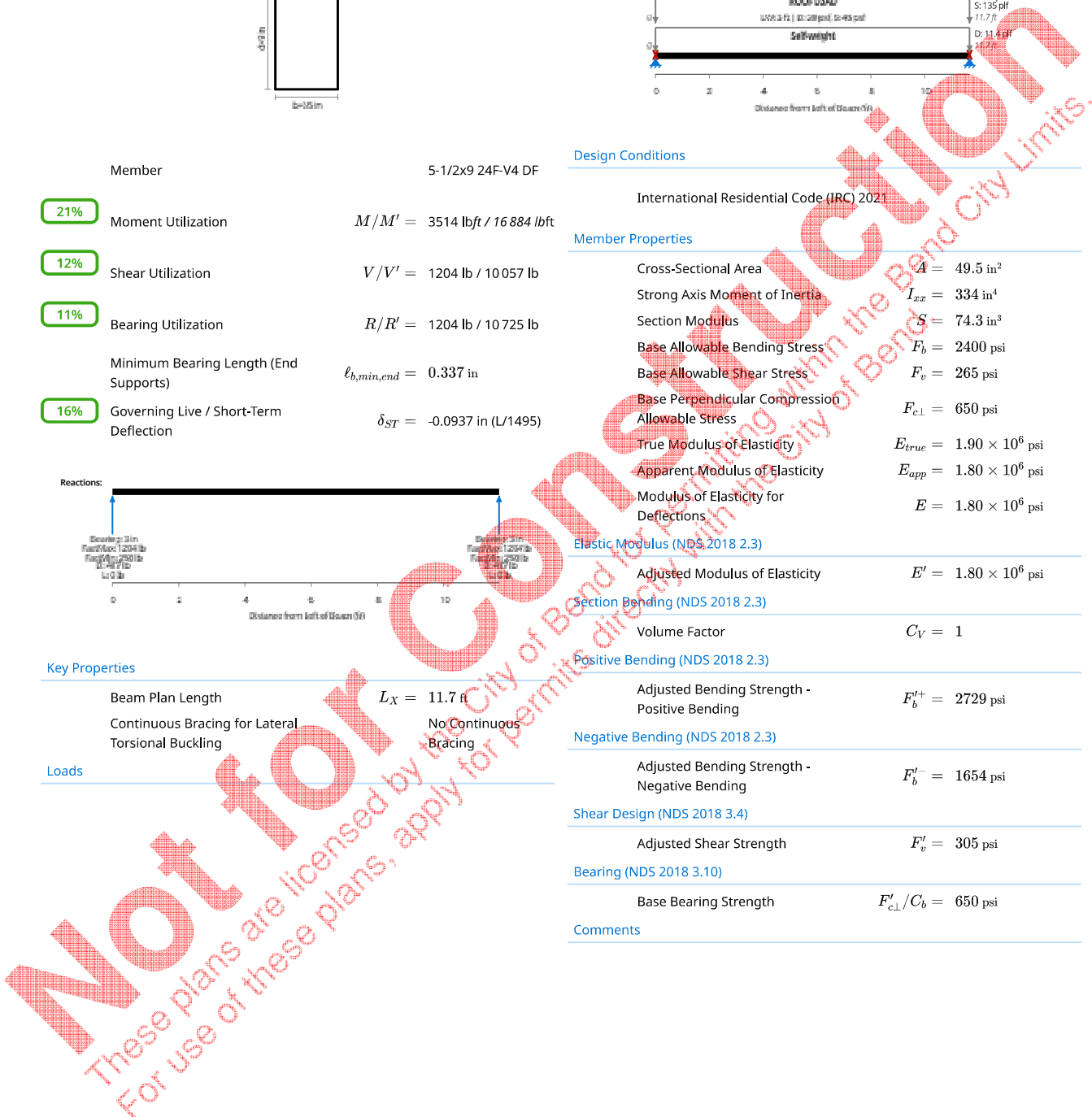



<b>Client:</b> SIERRA JAMES CONSTRUCTION	<b>Author:</b> Allison Rymut	<b>Date:</b> Jan 30, 2026
<b>Project:</b> DESCHUTES BUNGALOW		<b>Job #:</b>
<b>Address:</b>		<b>Subject:</b> 1RB3 (1 LEVEL BEAMS) <span style="border: 1px solid green; border-radius: 5px; padding: 2px;">PASS</span>
<b>References:</b> NDS 2018 (ASD)		

Summary

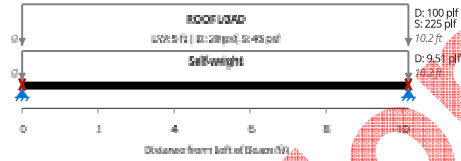
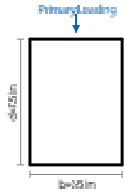

Member	5-1/2x7-1/2 24F-V4 DF
<span style="border: 1px solid green; border-radius: 5px; padding: 2px;">37%</span> Moment Utilization	$M/V' = 4325 \text{ lbft} / 11767 \text{ lbft}$
<span style="border: 1px solid green; border-radius: 5px; padding: 2px;">20%</span> Shear Utilization	$V/V' = 1701 \text{ lb} / 8381 \text{ lb}$
<span style="border: 1px solid green; border-radius: 5px; padding: 2px;">16%</span> Bearing Utilization	$R/R' = 1701 \text{ lb} / 10725 \text{ lb}$
Minimum Bearing Length (End Supports)	$\ell_{b,min,end} = 0.476 \text{ in}$
<span style="border: 1px solid green; border-radius: 5px; padding: 2px;">31%</span> Governing Live / Short-Term Deflection	$\delta_{ST} = -0.156 \text{ in} (L/784)$

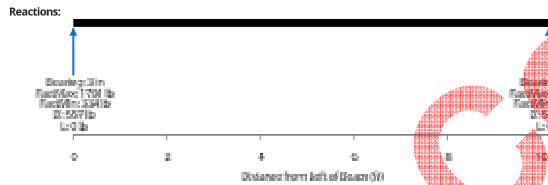

Key Properties

Beam Plan Length	$L_x = 10.2 \text{ ft}$
Continuous Bracing for Lateral Torsional Buckling	No Continuous Bracing

Loads

Design Conditions

International Residential Code (IRC) 2021

Member Properties

Strong Axis Moment of Inertia	$I_{xx} = 193 \text{ in}^4$
Section Modulus	$S = 51.6 \text{ in}^3$
Base Allowable Bending Stress	$F_b = 2400 \text{ psi}$
Base Allowable Shear Stress	$F_v = 265 \text{ psi}$
Base Perpendicular Compression Allowable Stress	$F_{c,\perp} = 650 \text{ psi}$

Elastic Modulus (NDS 2018 2.3)

Adjusted Modulus of Elasticity	$E' = 1.80 \times 10^6 \text{ psi}$
--------------------------------	-------------------------------------

Section Bending (NDS 2018 2.3)

Volume Factor	$C_V = 1$
---------------	-----------

Positive Bending (NDS 2018 2.3)

Adjusted Bending Strength - Positive Bending	$F_b^+ = 2739 \text{ psi}$
--	----------------------------

Negative Bending (NDS 2018 2.3)

Adjusted Bending Strength - Negative Bending	$F_b^- = 1658 \text{ psi}$
--	----------------------------

Shear Design (NDS 2018 3.4)

Adjusted Shear Strength	$F_v' = 305 \text{ psi}$
-------------------------	--------------------------

Bearing (NDS 2018 3.10)

Base Bearing Strength	$F_{c,\perp}'/C_b = 650 \text{ psi}$
-----------------------	--------------------------------------

Comments

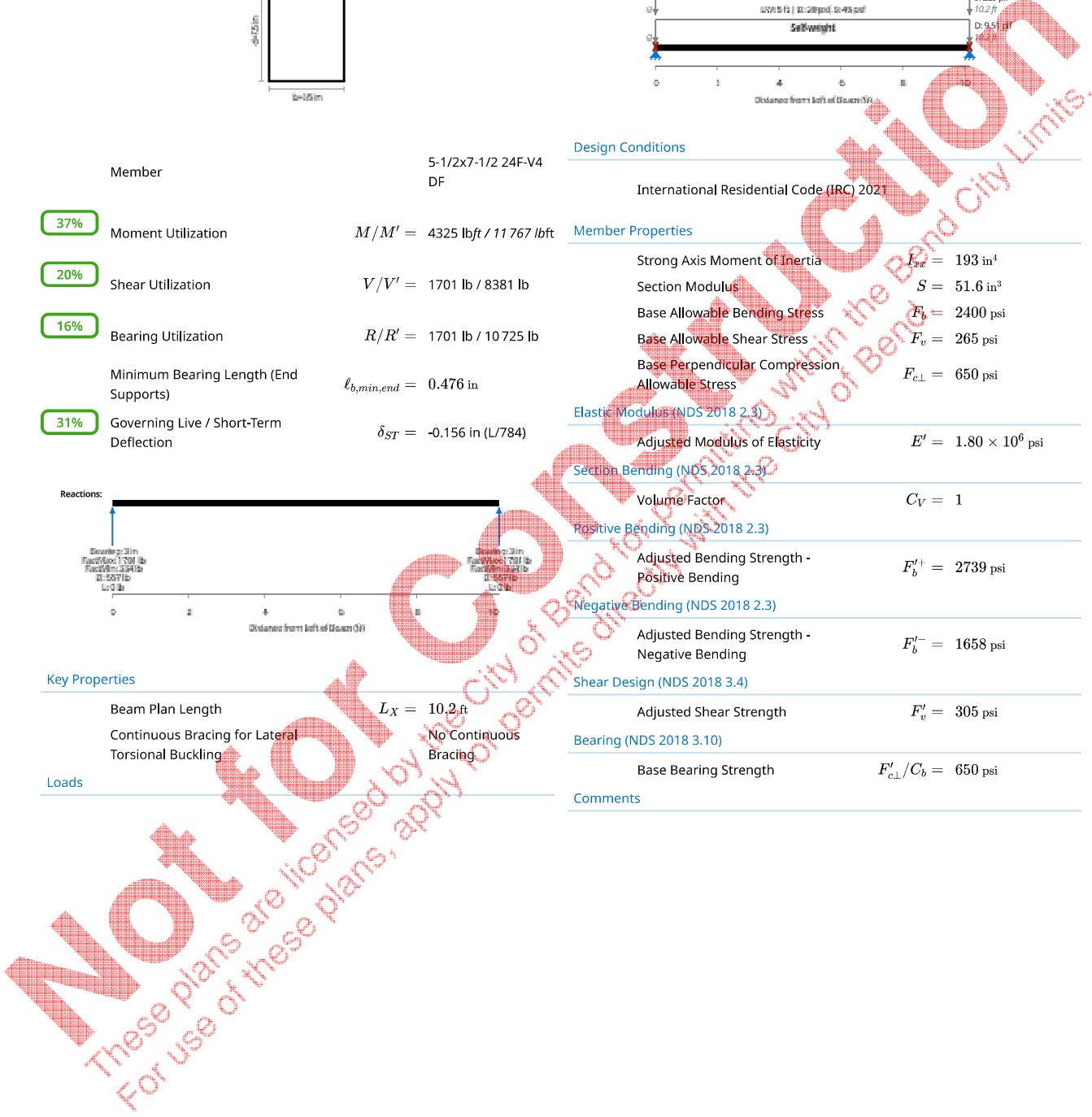



<b>Client:</b> SIERRA JAMES CONSTRUCTION	<b>Author:</b> Allison Rymut	<b>Date:</b> Jan 30, 2026
<b>Project:</b> DESCHUTES BUNGALOW		<b>Job #:</b>
<b>Address:</b>		<b>Subject:</b> OFB1 (0 LEVEL BEAMS) <span style="border: 1px solid green; border-radius: 5px; padding: 2px;">PASS</span>
<b>References:</b> NDS 2018 (ASD)		

Summary

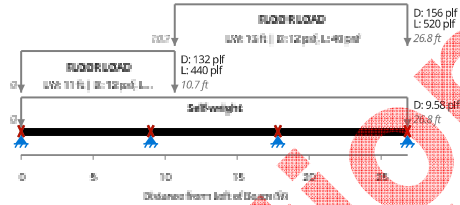
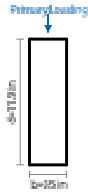

Member	3-1/2x11-7/8 TimberStrand LSL 1.55E-2325Fb
<span style="border: 1px solid green; border-radius: 5px; padding: 2px;">36%</span> Moment Utilization	$M/V' = -5579 \text{ lbft} / 15477 \text{ lbft}$
<span style="border: 1px solid green; border-radius: 5px; padding: 2px;">43%</span> Shear Utilization	$V/V' = 3705 \text{ lb} / 8590 \text{ lb}$
<span style="border: 1px solid green; border-radius: 5px; padding: 2px;">64%</span> Bearing Utilization	$R/R' = 6799 \text{ lb} / 10631 \text{ lb}$
Minimum Bearing Length (End Supports)	$\ell_{b,min,end} = 0.783 \text{ in}$
Minimum Bearing Length (Int Supports)	$\ell_{b,min,int} = 1.92 \text{ in}$
<span style="border: 1px solid green; border-radius: 5px; padding: 2px;">23%</span> Governing Live / Short-Term Deflection	$\delta_{ST} = -0.0685 \text{ in} (L/1577)$



Key Properties

Beam Plan Length	$L_x = 26.8 \text{ ft}$
Continuous Bracing for Lateral Torsional Buckling	No Continuous Bracing

Loads

Design Conditions

International Residential Code (IRC) 2021

Member Properties

Cross-Sectional Area	$A = 41.6 \text{ in}^2$
Strong Axis Moment of Inertia	$I_{xx} = 488 \text{ in}^4$
Section Modulus	$S = 82.3 \text{ in}^3$
Base Allowable Bending Stress	$F_b = 2325 \text{ psi}$
Base Allowable Shear Stress	$F_v = 310 \text{ psi}$
Base Perpendicular Compression Allowable Stress	$F_{c,L} = 900 \text{ psi}$
True Modulus of Elasticity	$E_{true} = 1.55 \times 10^6 \text{ psi}$
Apparent Modulus of Elasticity	$E_{app} = NaN \text{ psi}$
Modulus of Elasticity for Deflections	$E = 1.55 \times 10^6 \text{ psi}$

Elastic Modulus (NDS 2018 2.3)

Adjusted Modulus of Elasticity	$E' = 1.55 \times 10^6 \text{ psi}$
Adjusted Shear Modulus	$G' = 96875 \text{ psi}$

Section Bending (NDS 2018 2.3)

Volume Factor	$C_V = 1$
---------------	-----------

Positive Bending (NDS 2018 2.3)

Adjusted Bending Strength - Positive Bending	$F_b^{'+} = 2258 \text{ psi}$
--	-------------------------------

Negative Bending (NDS 2018 2.3)

Adjusted Bending Strength - Negative Bending	$F_b'^{-} = 2258 \text{ psi}$
--	-------------------------------

Shear Design (NDS 2018 3.4)

Adjusted Shear Strength	$F_v' = 310 \text{ psi}$
-------------------------	--------------------------

Bearing (NDS 2018 3.10)

Base Bearing Strength	$F'_{c,L}/C_b = 900 \text{ psi}$
-----------------------	----------------------------------

Comments

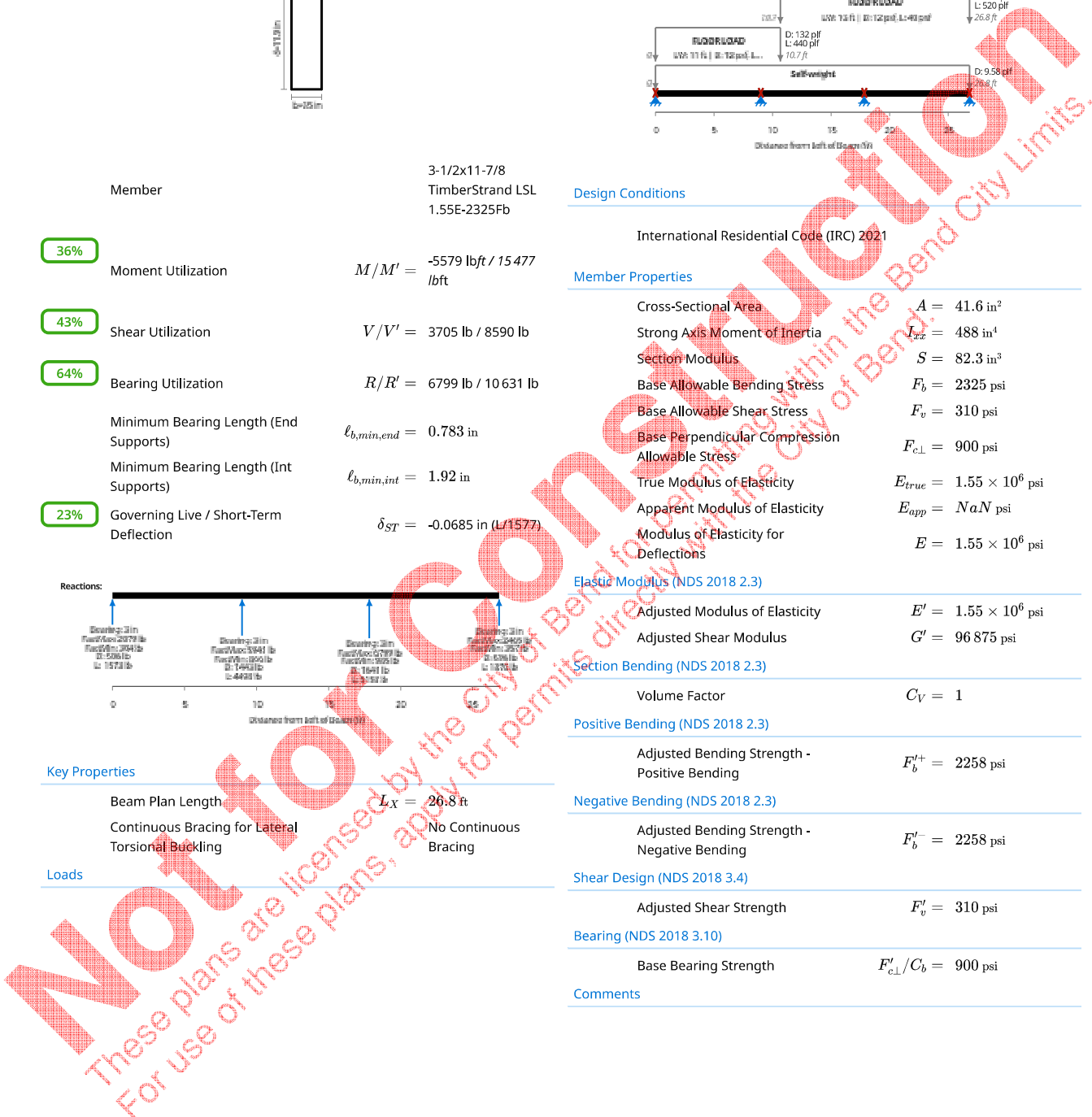



<b>Client:</b> SIERRA JAMES CONSTRUCTION	<b>Author:</b> Allison Rymut	<b>Date:</b> Jan 30, 2026
<b>Project:</b> DESCHUTES BUNGALOW		<b>Job #:</b>
<b>Address:</b>	<b>Subject:</b> FLOOR JOISTS [BCI] (0 LEVEL BEAMS)	<b>PASS</b>
<b>References:</b> NDS 2018 (ASD)		

Summary

Loads

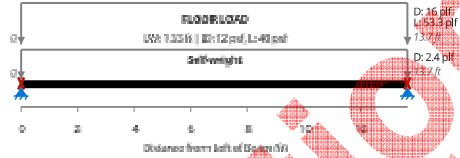
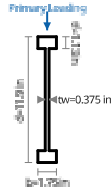

Member	11-7/8" BCI-4500s1.8
<b>55%</b> Moment Utilization	$M/M' = 1676 \text{ lbft} / 3025 \text{ lbft}$
<b>30%</b> Shear Utilization	$V/V' = 490 \text{ lb} / 1625 \text{ lb}$
<b>38%</b> Bearing Utilization	$R/R' = 490 \text{ lb} / 1306 \text{ lb}$
<b>40%</b> Governing Live / Short-Term Deflection	$\delta_{ST} = -0.181 \text{ in} (L/906)$

Center-to-Center Spacing (= tributary width)  $s = 16 \text{ in}$

Design Conditions

International Residential Code (IRC) 2021

Member Properties

Base Allowable Moment	$M_r = 3025 \text{ lb} \cdot \text{ft}$
Base Allowable Shear	$V_r = 1625 \text{ lb}$
Base Perpendicular Compression Allowable Stress	$F_{c \perp} = 0 \text{ psi}$

Section Bending (NDS 2018 2.3)

Beam Stability Factor	$C_L = 1$
Adjusted Allowable Moment	$M'_r = 3025 \text{ lb} \cdot \text{ft}$

Shear Design (NDS 2018 3.4)

Adjusted Allowable Shear	$V'_r = 1625 \text{ lb}$
--------------------------	--------------------------

Bearing (NDS 2018 3.10)

Base Bearing Strength	$F'_{c \perp} / C_b = 0 \text{ psi}$
-----------------------	--------------------------------------

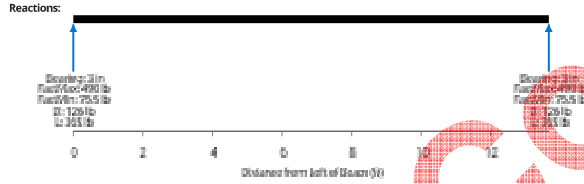

Key Properties

Beam Plan Length  $L_X = 13.7 \text{ ft}$

Comments

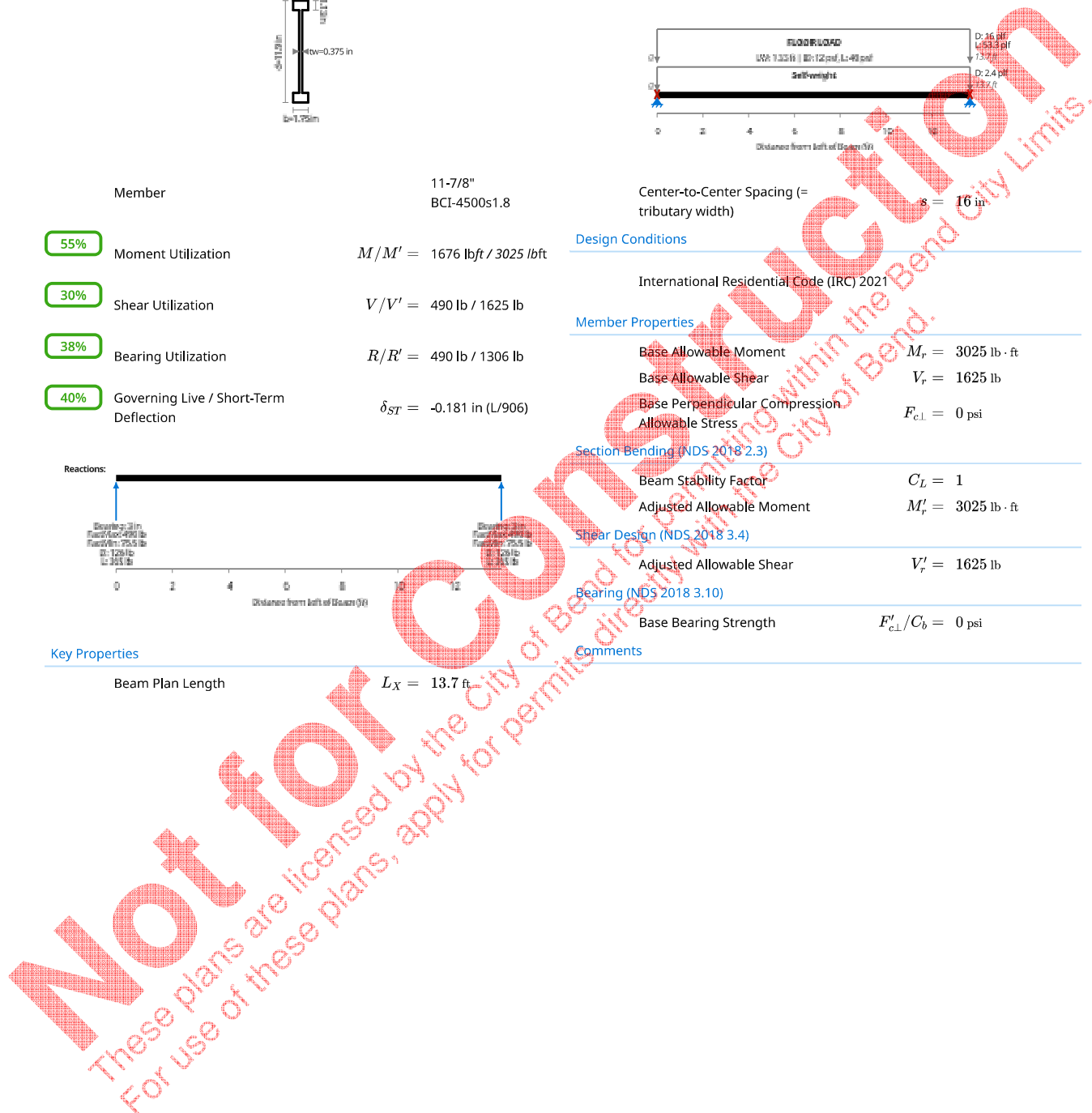



<b>Client:</b> SIERRA JAMES CONSTRUCTION	<b>Author:</b> Allison Rymut	<b>Date:</b> Jan 30, 2026
<b>Project:</b> DESCHUTES BUNGALOW		<b>Job #:</b>
<b>Address:</b>	<b>Subject:</b> FLOOR JOISTS [TJI] (0 LEVEL BEAMS) <span style="border: 1px solid green; border-radius: 5px; padding: 2px;">PASS</span>	
<b>References:</b> NDS 2018 (ASD)		

Summary

Loads

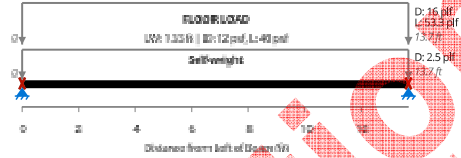
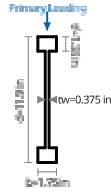

Member	11-7/8" TJI 110
<span style="border: 1px solid green; border-radius: 5px; padding: 2px;">53%</span> Moment Utilization	$M/M' = 1678 \text{ lbft} / 3160 \text{ lbft}$
<span style="border: 1px solid green; border-radius: 5px; padding: 2px;">31%</span> Shear Utilization	$V/V' = 491 \text{ lb} / 1560 \text{ lb}$
<span style="border: 1px solid green; border-radius: 5px; padding: 2px;">40%</span> Bearing Utilization	$R/R' = 491 \text{ lb} / 1242 \text{ lb}$
<span style="border: 1px solid green; border-radius: 5px; padding: 2px;">39%</span> Governing Live / Short-Term Deflection	$\delta_{ST} = -0.179 \text{ in} (L/915)$

Center-to-Center Spacing (= tributary width)  $s = 16 \text{ in}$

Design Conditions

International Residential Code (IRC) 2021

Member Properties

Base Allowable Moment	$M_r = 3160 \text{ lb} \cdot \text{ft}$
Base Allowable Shear	$V_r = 1560 \text{ lb}$
Base Perpendicular Compression Allowable Stress	$F_{c \perp} = 0 \text{ psi}$

Section Bending (NDS 2018 2.3)

Beam Stability Factor	$C_L = 1$
Adjusted Allowable Moment	$M'_r = 3160 \text{ lb} \cdot \text{ft}$

Shear Design (NDS 2018 3.4)

Adjusted Allowable Shear	$V'_r = 1560 \text{ lb}$
--------------------------	--------------------------

Bearing (NDS 2018 3.10)

Base Bearing Strength	$F'_{c \perp} / C_b = 0 \text{ psi}$
-----------------------	--------------------------------------

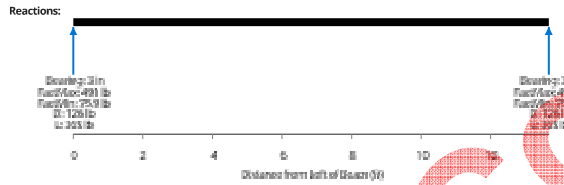

Key Properties

Beam Plan Length  $L_x = 13.7 \text{ ft}$

Comments

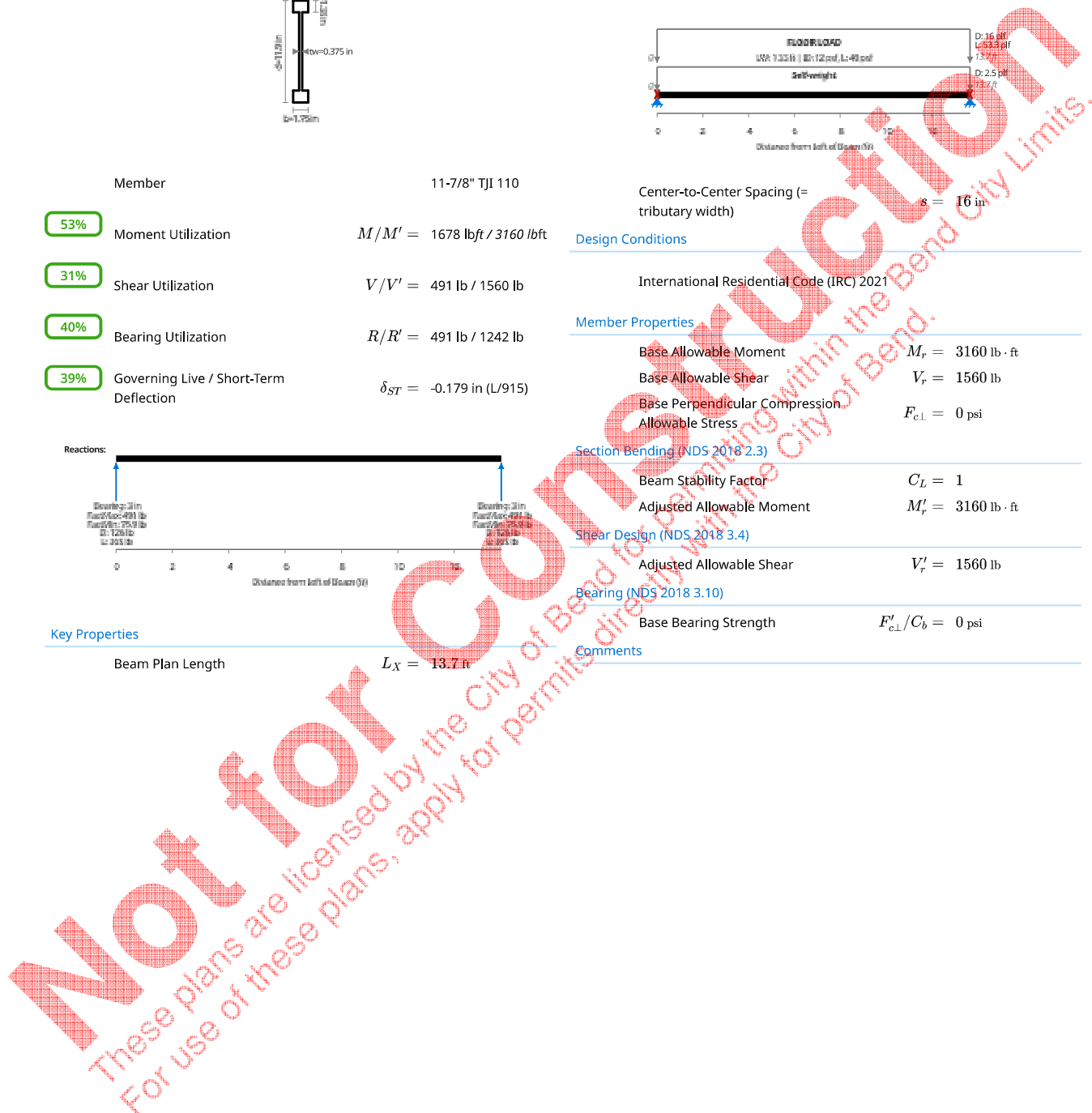



<b>Client:</b> SIERRA JAMES CONSTRUCTION	<b>Author:</b> Allison Rymut	<b>Date:</b> Jan 30, 2026
<b>Project:</b> DESCHUTES BUNGALOW		<b>Job #:</b>
<b>Address:</b>	<b>Subject:</b> FLOOR JOISTS [LPI] (0 LEVEL BEAMS)	<b>PASS</b>
<b>References:</b> NDS 2018 (ASD)		

Summary

Loads

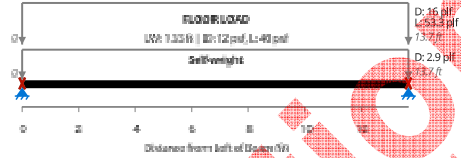
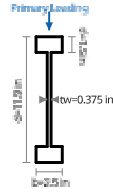

Member	11-7/8" LPI 18
<b>54%</b> Moment Utilization	$M/M' = 1687 \text{ lbft} / 3100 \text{ lbft}$
<b>37%</b> Shear Utilization	$V/V' = 494 \text{ lb} / 1335 \text{ lb}$
<b>51%</b> Bearing Utilization	$R/R' = 494 \text{ lb} / 972 \text{ lb}$
<b>42%</b> Governing Live / Short-Term Deflection	$\delta_{ST} = -0.192 \text{ in} (L/855)$

Center-to-Center Spacing (= tributary width)  $s = 16 \text{ in}$

Design Conditions

International Residential Code (IRC) 2021

Member Properties

Base Allowable Moment	$M_r = 3100 \text{ lb} \cdot \text{ft}$
Base Allowable Shear	$V_r = 1335 \text{ lb}$
Base Perpendicular Compression Allowable Stress	$F_{c \perp} = 955 \text{ psi}$

Section Bending (NDS 2018 2.3)

Beam Stability Factor	$C_L = 1$
Adjusted Allowable Moment	$M'_r = 3100 \text{ lb} \cdot \text{ft}$

Shear Design (NDS 2018 3.4)

Adjusted Allowable Shear	$V'_r = 1335 \text{ lb}$
--------------------------	--------------------------

Bearing (NDS 2018 3.10)

Base Bearing Strength	$F'_{c \perp} / C_b = 955 \text{ psi}$
-----------------------	--

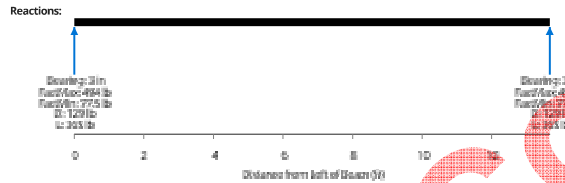

Key Properties

Beam Plan Length  $L_X = 13.7 \text{ ft}$

Comments

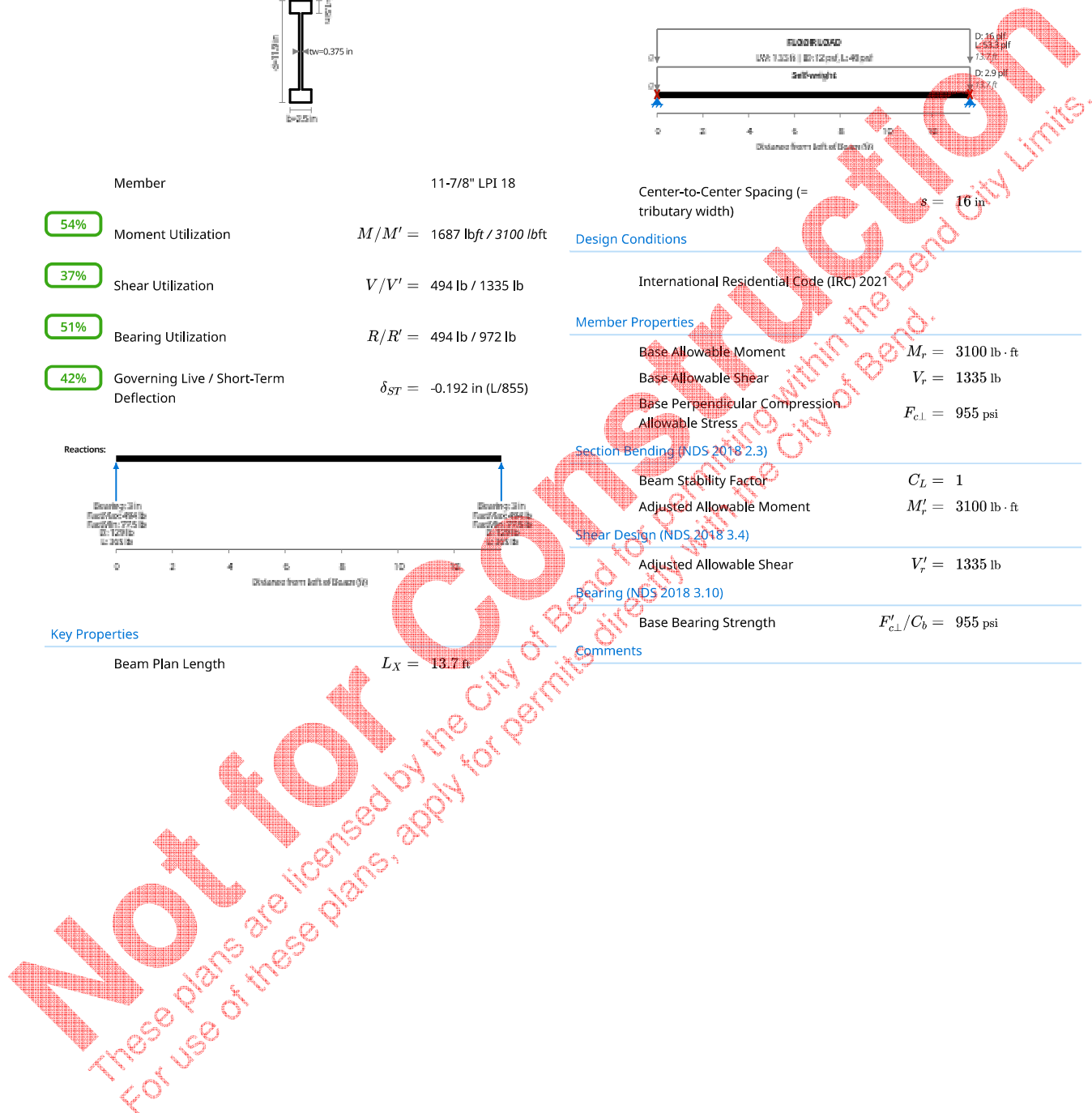



<b>Client:</b> SIERRA JAMES CONSTRUCTION	<b>Author:</b> Allison Rymut	<b>Date:</b> Jan 30, 2026
<b>Project:</b> DESCHUTES BUNGALOW		<b>Job #:</b>
<b>Address:</b>	<b>Subject:</b> FLOOR JOISTS [RFPI] (0 LEVEL BEAMS)	<b>PASS</b>
<b>References:</b> NDS 2018 (ASD)		

Summary

Loads

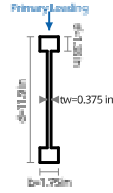

Member	11-7/8" RFPI 20
<b>46%</b> Moment Utilization	$M/M' = 1675 \text{ lbft} / 3640 \text{ lbft}$
<b>35%</b> Shear Utilization	$V/V' = 490 \text{ lb} / 1420 \text{ lb}$
<b>40%</b> Bearing Utilization	$R/R' = 490 \text{ lb} / 1211 \text{ lb}$
<b>37%</b> Governing Live / Short-Term Deflection	$\delta_{ST} = -0.167 \text{ in} (L/980)$

Center-to-Center Spacing (= tributary width)  $s = 16 \text{ in}$

Design Conditions

International Residential Code (IRC) 2021

Member Properties

Base Allowable Moment	$M_r = 3640 \text{ lb} \cdot \text{ft}$
Base Allowable Shear	$V_r = 1420 \text{ lb}$
Base Perpendicular Compression Allowable Stress	$F_{c \perp} = 600 \text{ psi}$

Section Bending (NDS 2018 2.3)

Beam Stability Factor	$C_L = 1$
Adjusted Allowable Moment	$M'_r = 3640 \text{ lb} \cdot \text{ft}$

Shear Design (NDS 2018 3.4)

Adjusted Allowable Shear	$V'_r = 1420 \text{ lb}$
--------------------------	--------------------------

Bearing (NDS 2018 3.10)

Base Bearing Strength	$F'_{c \perp} / C_b = 600 \text{ psi}$
-----------------------	--

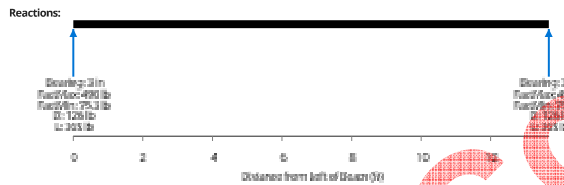

Key Properties

Beam Plan Length  $L_x = 13.7 \text{ ft}$

Comments

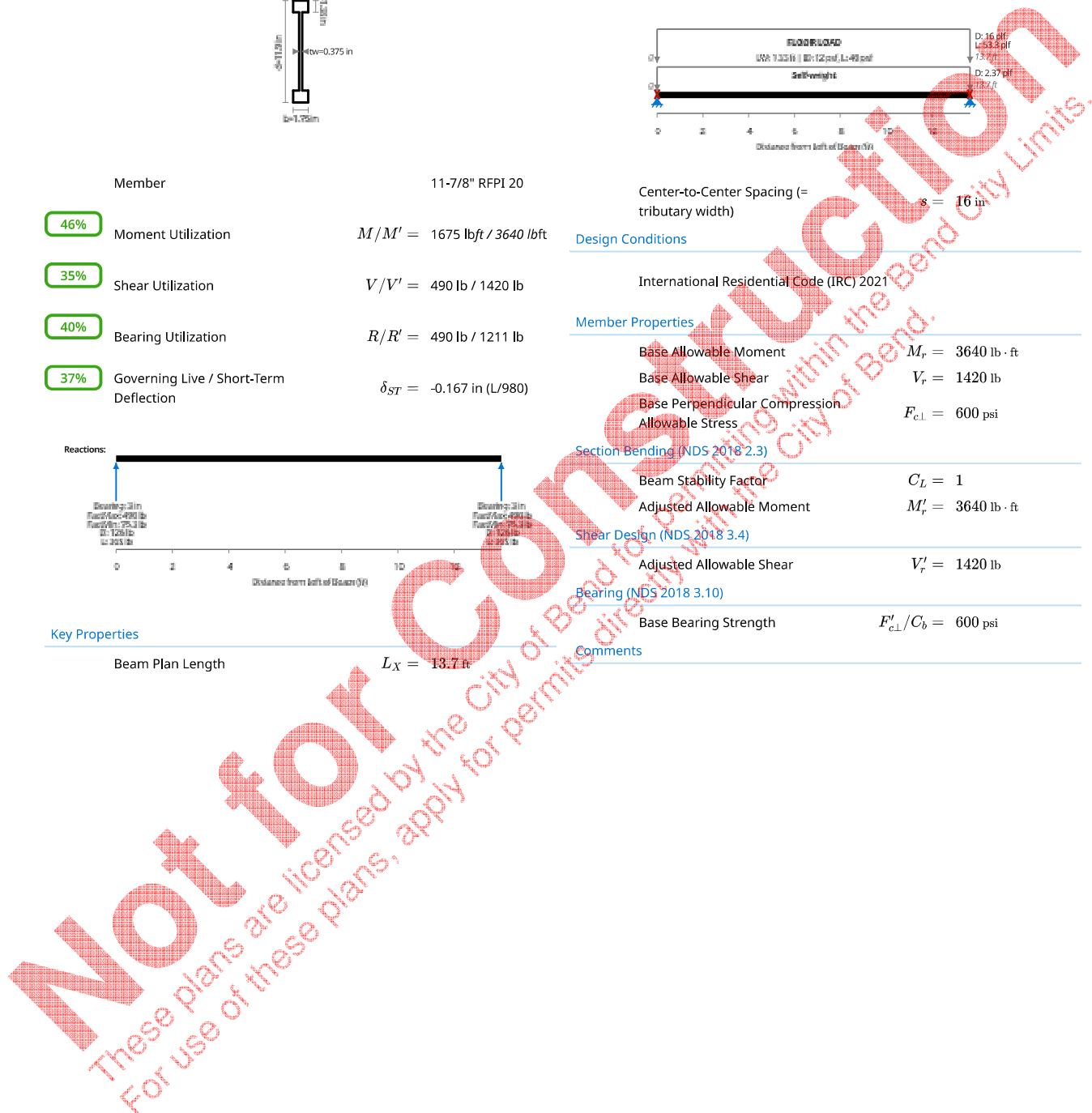



<b>Client:</b> SIERRA JAMES CONSTRUCTION	<b>Author:</b> Allison Rymut	<b>Date:</b> Jan 30, 2026
<b>Project:</b> DESCHUTES BUNGALOW		<b>Job #:</b>
<b>Address:</b>		<b>Subject:</b> WF1 (FOUNDATION) <span style="border: 1px solid green; border-radius: 5px; padding: 2px;">PASS</span>
<b>References:</b> ACI 318-19		

Summary

Service Soil Bearing Stress	$q_s = 1424$ psf
<span style="border: 1px solid orange; border-radius: 5px; padding: 2px;">95%</span> Allowable Gross Soil Bearing Stress	$q_a = 1500$ psf
<span style="border: 1px solid green; border-radius: 5px; padding: 2px;">15%</span> Factored Moment Capacity	$\phi M_n = 400$ lb · ft/ft
<span style="border: 1px solid green; border-radius: 5px; padding: 2px;">0%</span> Factored One-Way Shear Capacity	$\phi V_n = 1920$ plf
Uplift Safety Factor	$FS_u =$ Uplift has not been found
Stability	Status = Footing in Total Compression

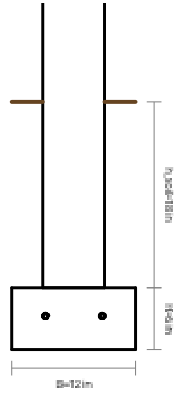

Footing Properties

Footing Width	$B = 1$ ft
Footing Thickness	$H = 6$ in
Wall Type	Concrete
Wall Width	$b = 6$ in
Concrete Strength	$f'_c = 2500$ psi
Volume of Concrete	$V_c = 0.0185$ yd <sup>3</sup> /ft

Soil Properties

Allowable Soil Gross Bearing Capacity	$q_a = 1500$ psf
Lateral Sliding Coefficient of Friction	$\mu = 0.3$

Bottom Reinforcement

Concrete Cover	cover = 3 in
Reinforcement Yield Strength	$f_y = 40000$ psi

Design Criteria

Design Code for Load Combinations	International Residential Code (IRC) 2021
Sliding and Overturning Minimum Factor of Safety	$FS_{min} = 1.5$

Comments

Not for Construction  
 These plans are licensed by the City of Bend for permitting within the Bend City Limits.  
 For use of these plans, apply for permits directly with the City of Bend.



<b>Client:</b> SIERRA JAMES CONSTRUCTION	<b>Author:</b> Allison Rymut	<b>Date:</b> Jan 30, 2026
<b>Project:</b> DESCHUTES BUNGALOW		<b>Job #:</b>
<b>Address:</b>		<b>Subject:</b> F1 (FOUNDATION) <span style="border: 1px solid green; border-radius: 5px; padding: 2px;">PASS</span>
<b>References:</b> ACI 318-19		

Summary

Soil Gross Bearing Stress	$q_s = 1402$ psf
<span style="border: 1px solid orange; border-radius: 5px; padding: 2px;">93%</span> Allowable Gross Soil Bearing Stress	$q_a = 1500$ psf
<span style="border: 1px solid green; border-radius: 5px; padding: 2px;">39%</span> Factored Moment Capacity about X-Axis	$\phi M_{nx} = 5825$ lb · ft
<span style="border: 1px solid green; border-radius: 5px; padding: 2px;">39%</span> Factored Moment Capacity about Y-Axis	$\phi M_{ny} = 5825$ lb · ft
<span style="border: 1px solid green; border-radius: 5px; padding: 2px;">13%</span> Factored One-Way Shear Strength	$\phi V_n = 11\,184$ lb
<span style="border: 1px solid green; border-radius: 5px; padding: 2px;">18%</span> Two-Way Shear Capacity	$\phi v_n = 80$ psi
<span style="border: 1px solid green; border-radius: 5px; padding: 2px;">33%</span> Concrete Bearing Capacity	$\phi S_n = 31\,237$ lb
Development Length for X-Axis Reinforcement	$\ell_{dx} = 12$ in

Design Passes as Plain Concrete (X-Axis)?  $PC_x =$  Insufficient development length but passes as plain concrete

Development Length for Y-Axis Reinforcement  $\ell_{dy} = 12$  in

Design Passes as Plain Concrete (Y-Axis)?  $PC_y =$  Insufficient development length but passes as plain concrete

Uplift Safety Factor  $FS_u =$  Uplift has not been found

Stability Status Footing in Total Compression

- (4) - #4 X-Bars
- (4) - #4 Y-Bars

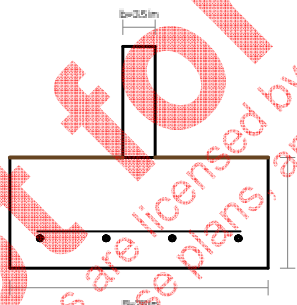

Footing Properties

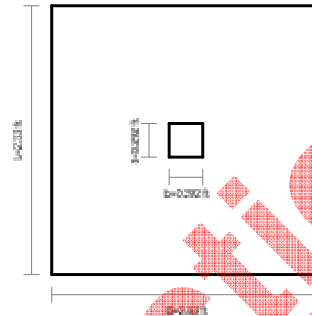

Concrete Strength  $f'_c = 2500$  psi  
 Volume of Concrete  $V_c = 0.201$  yd<sup>3</sup>

Soil Properties

Allowable Soil Gross Bearing Capacity  $q_a = 1500$  psf  
 Lateral Sliding Coefficient of Friction  $\mu = 0.3$

Bottom Reinforcement

Concrete Cover cover = 3 in  
 Reinforcement Yield Strength  $f_y = 40\,000$  psi  
 Ends of Reinforcement - X-Axis Straight  
 Ends of Reinforcement - Y-Axis Straight

Bottom Reinforcement Depth & Spacing

Steel Area - X-Axis Bending  $A_{sx} = 0.8$  in<sup>2</sup>  
 Steel Area - Y-Axis Bending  $A_{sy} = 0.8$  in<sup>2</sup>

Applied Loads

Biaxial Moments Applied Separately  
 Axial, Shear, & Moment Loads about X-axis  $V, P, M =$

Label	Location z (ft)	Axial Eccentricity y (in)	Load Magnitudes V, P, M
OFB1-3 (0 LEVEL BEAMS)	0	0	D: 0 lb, 1641 lb, 0 lb ft, L: 0 lb, 5158 lb, 0 lb ft

Design Criteria

Design Code for Load Combinations International Residential Code (IRC) 2021

Negative Bending Flexural Capacity - X-Axis (ACI 318-19, CI 22.2)

0% Factored Negative Moment Capacity  $\phi M_{nx}^- = 5825$  lb · ft

Negative Bending Flexural Capacity - Y-Axis (ACI 318-19, CI 22.2)

0% Factored Negative Moment Capacity  $\phi M_{ny}^- = 5825$  lb · ft

Comments

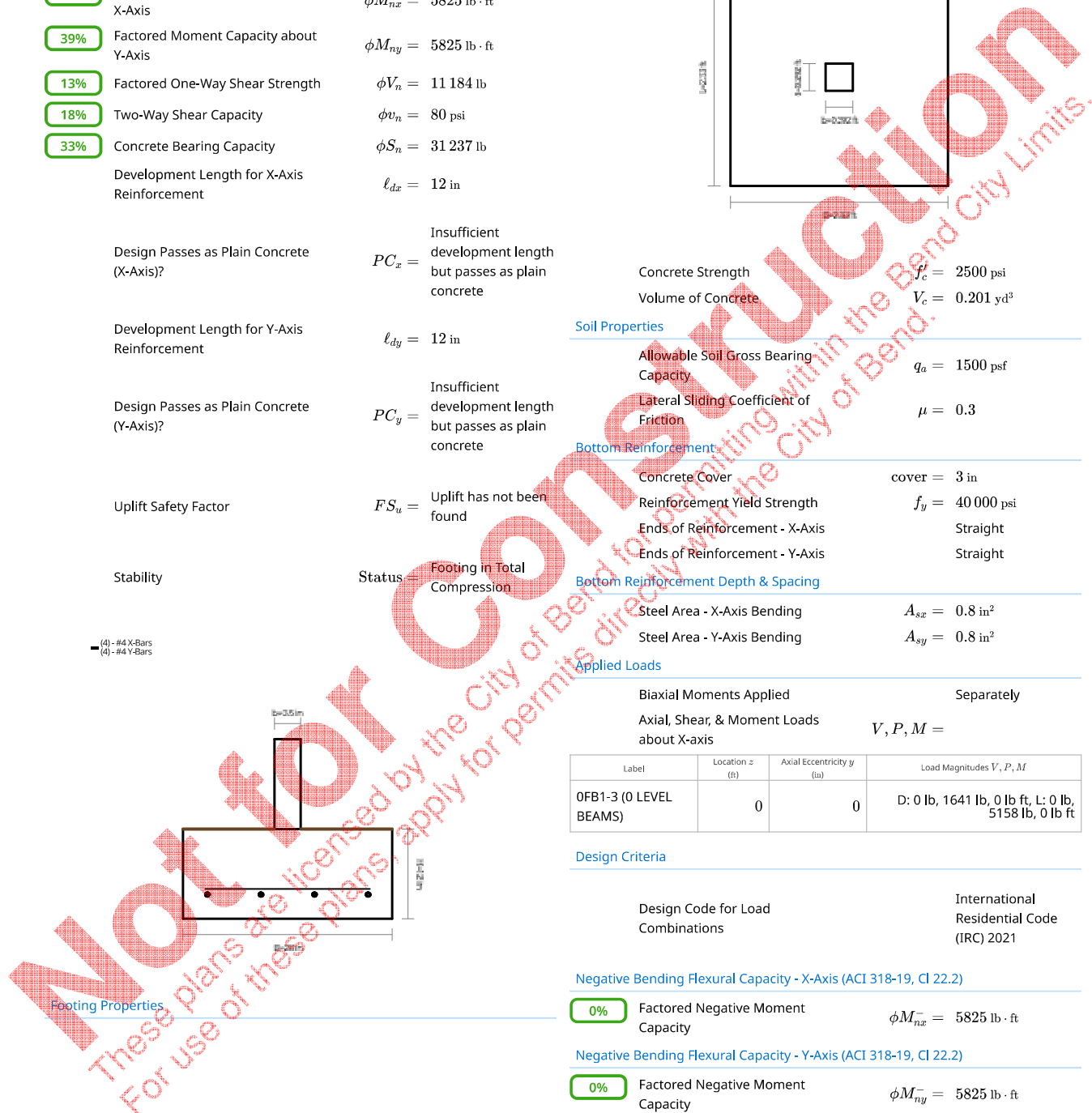



<b>Client:</b> SIERRA JAMES CONSTRUCTION	<b>Author:</b> Allison Rymut	<b>Date:</b> Jan 30, 2026
<b>Project:</b> DESCHUTES BUNGALOW		<b>Job #:</b>
<b>Address:</b>		<b>Subject:</b> 1RB4 (1 LEVEL BEAMS) <span style="border: 1px solid green; border-radius: 5px; padding: 2px;">PASS</span>
<b>References:</b> NDS 2018 (ASD)		

Summary

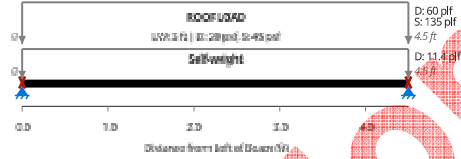
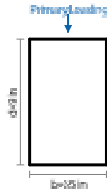

Member	5-1/2x9 24F-V4 DF
<span style="border: 1px solid green; border-radius: 5px; padding: 2px;">3%</span> Moment Utilization	$M/M' = 522 \text{ lbft} / 16\,993 \text{ lbft}$
<span style="border: 1px solid green; border-radius: 5px; padding: 2px;">5%</span> Shear Utilization	$V/V' = 464 \text{ lb} / 10\,057 \text{ lb}$
<span style="border: 1px solid green; border-radius: 5px; padding: 2px;">4%</span> Bearing Utilization	$R/R' = 464 \text{ lb} / 10\,725 \text{ lb}$
Minimum Bearing Length (End Supports)	$\ell_{b,min,end} = 0.13 \text{ in}$
<span style="border: 1px solid green; border-radius: 5px; padding: 2px;">1%</span> Governing Live / Short-Term Deflection	$\delta_{ST} = -0.00207 \text{ in} (L/26\,076)$

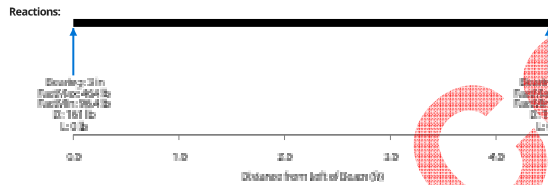

Key Properties

Beam Plan Length	$L_x = 4.5 \text{ ft}$
Continuous Bracing for Lateral Torsional Buckling	No Continuous Bracing

Loads

Design Conditions

International Residential Code (IRC) 2021

Member Properties

Cross-Sectional Area	$A = 49.5 \text{ in}^2$
Strong Axis Moment of Inertia	$I_{xx} = 334 \text{ in}^4$
Section Modulus	$S = 74.3 \text{ in}^3$
Base Allowable Bending Stress	$F_b = 2400 \text{ psi}$
Base Allowable Shear Stress	$F_v = 265 \text{ psi}$
Base Perpendicular Compression Allowable Stress	$F_{c,L} = 650 \text{ psi}$
True Modulus of Elasticity	$E_{true} = 1.90 \times 10^6 \text{ psi}$
Apparent Modulus of Elasticity	$E_{app} = 1.80 \times 10^6 \text{ psi}$
Modulus of Elasticity for Deflections	$E = 1.80 \times 10^6 \text{ psi}$

Elastic Modulus (NDS 2018 2.3)

Adjusted Modulus of Elasticity	$E' = 1.80 \times 10^6 \text{ psi}$
--------------------------------	-------------------------------------

Section Bending (NDS 2018 2.3)

Volume Factor	$C_V = 1$
---------------	-----------

Positive Bending (NDS 2018 2.3)

Adjusted Bending Strength - Positive Bending	$F_b^{'+} = 2746 \text{ psi}$
--	-------------------------------

Negative Bending (NDS 2018 2.3)

Adjusted Bending Strength - Negative Bending	$F_b^{'-} = 1660 \text{ psi}$
--	-------------------------------

Shear Design (NDS 2018 3.4)

Adjusted Shear Strength	$F_v' = 305 \text{ psi}$
-------------------------	--------------------------

Bearing (NDS 2018 3.10)

Base Bearing Strength	$F'_{c,L}/C_b = 650 \text{ psi}$
-----------------------	----------------------------------

Comments

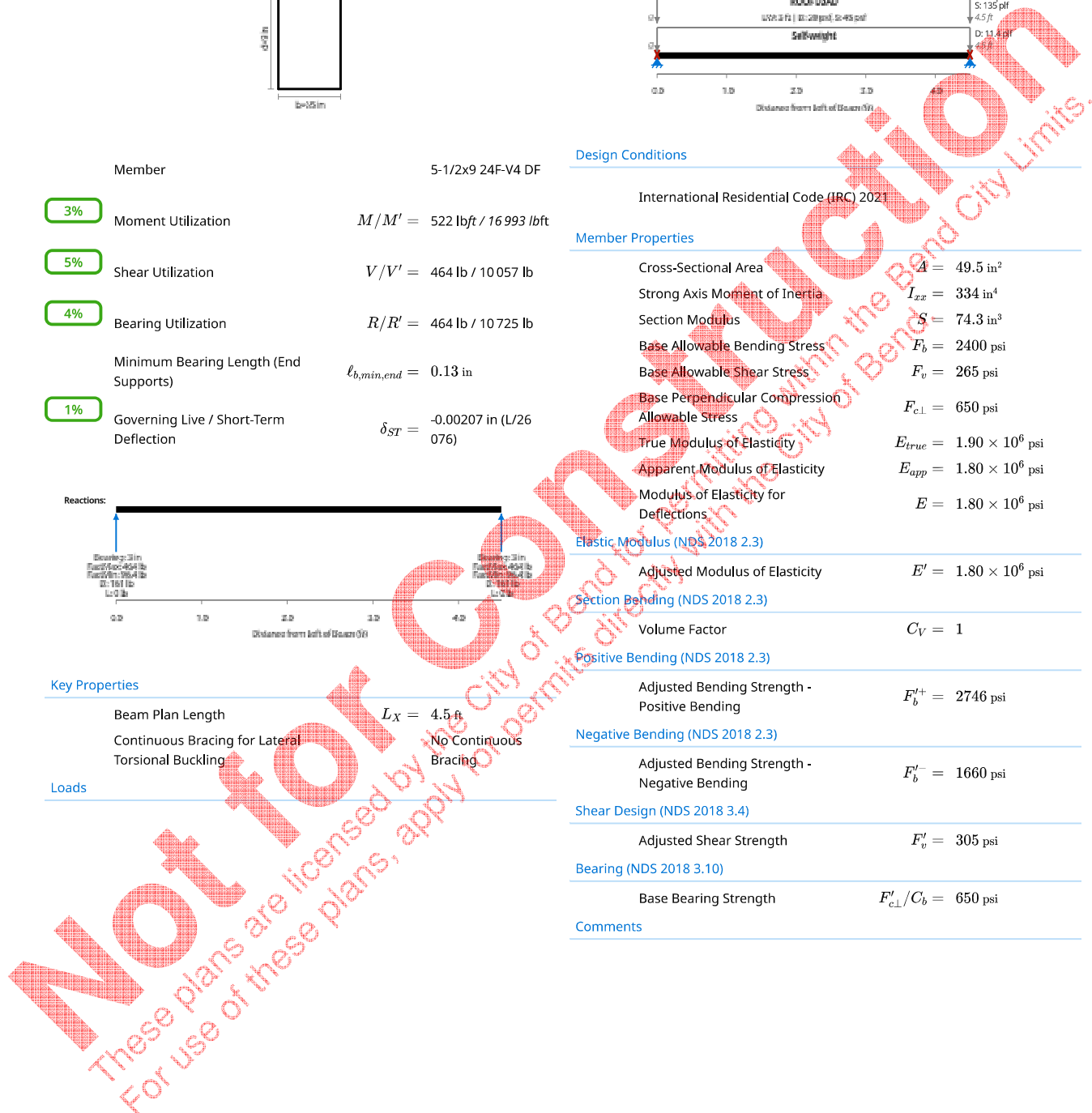

**MiTek, Inc.**

400 Sunrise Ave., Suite 270  
Roseville, CA 95661  
916.755.3571

Re: 5268888

Sierra James - Deschutes Bungalow

The truss drawing(s) referenced below have been prepared by MiTek USA, Inc. under my direct supervision based on the parameters provided by Builders FirstSource (Beaverton, OR).

Pages or sheets covered by this seal: R93029747 thru R93029753

My license renewal date for the state of Oregon is December 31, 2026.



March 5, 2026

Reinmuth, Dustin

**IMPORTANT NOTE:** The seal on these truss component designs is a certification that the engineer named is licensed in the jurisdiction(s) identified and that the designs comply with ANSI/TPI 1. These designs are based upon parameters shown (e.g., loads, supports, dimensions, shapes and design codes), which were given to MiTek or TRENCO. Any project specific information included is for MiTek's or TRENCO's customers file reference purpose only, and was not taken into account in the preparation of these designs. MiTek or TRENCO has not independently verified the applicability of the design parameters or the designs for any particular building. Before use, the building designer should verify applicability of design parameters and properly incorporate these designs into the overall building design per ANSI/TPI 1, Chapter 2.

Job 5268888	Truss A01	Truss Type Common Supported Gable	Qty 2	Ply 1	Sierra James - Deschutes Bungalow Job Reference (optional)	R93029747
----------------	--------------	--------------------------------------	----------	----------	---	-----------

Builders FirstSource (Beaverton, OR), Beaverton, OR - 97005,

Run: 8.83 S Jan 22 2026 Print: 8.830 S Jan 22 2026 MiTek Industries, Inc. Thu Mar 05 14:24:21  
ID:qNMG4Vqyil442lBssEDP12zkT7qRfC?PsB70Hq3NSgPqnl8w3uTXbGKwRcDoi7J4zJC?F

Page: 1

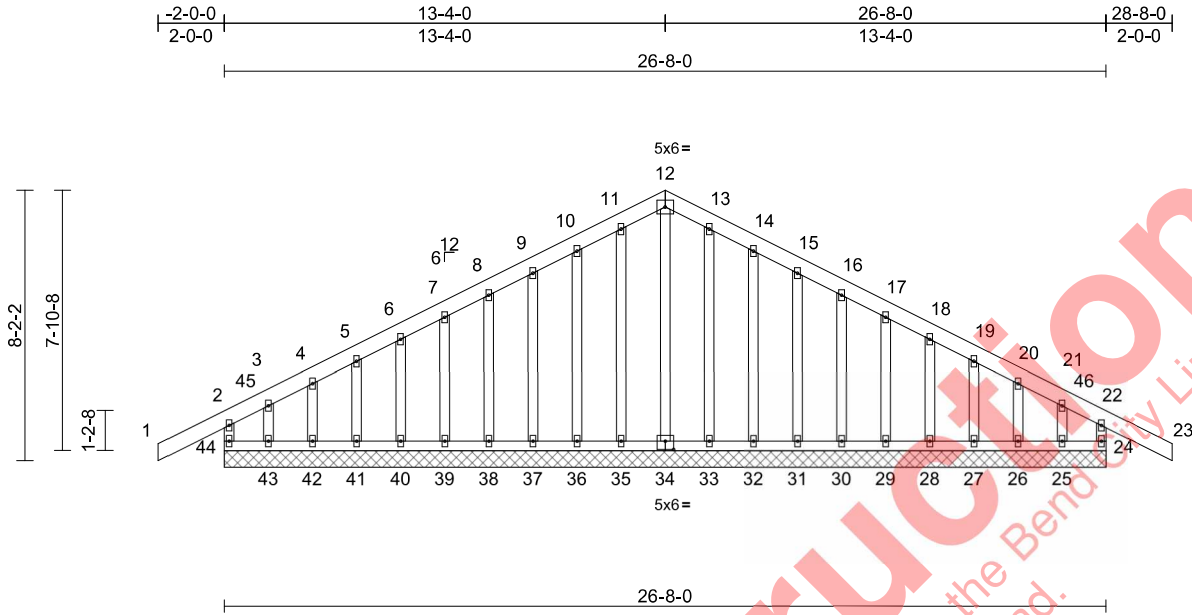

Scale = 1:69.7

Plate Offsets (X, Y): [34:0-3-0,0-3-0]

Loading	(psf)	Spacing	2-0-0	CSI	DEFL	in	(loc)	l/defl	L/d	PLATES	GRIP	
TCLL (roof)	35.0	Plate Grip DOL	1.15	TC	0.19	Vert(LL)	n/a	-	n/a	999	MT20	220/195
Snow (Pf/Pg)	34.7/50.0	Lumber DOL	1.15	BC	0.03	Vert(CT)	n/a	-	n/a	999		
TCDL	10.0	Rep Stress Incr	YES	WB	0.15	Horz(CT)	0.00	24	n/a	n/a		
BCLL	0.0*	Code	IBC2021/TPI2014	Matrix-R								
BCDL	10.0											
											Weight: 214 lb	FT = 10%

**LUMBER**  
TOP CHORD 2x6 DF No.2  
BOT CHORD 2x4 DF No.2  
WEBS 2x4 DF Stud/Std  
OTHERS 2x4 DF Stud/Std

**BRACING**  
TOP CHORD Structural wood sheathing directly applied or 6-0-0 oc purlins, except end verticals.  
BOT CHORD Rigid ceiling directly applied or 6-0-0 oc bracing.

**REACTIONS** (size)  
24=26-8-0, 25=26-8-0, 26=26-8-0,  
27=26-8-0, 28=26-8-0, 29=26-8-0,  
30=26-8-0, 31=26-8-0, 32=26-8-0,  
33=26-8-0, 34=26-8-0, 35=26-8-0,  
36=26-8-0, 37=26-8-0, 38=26-8-0,  
39=26-8-0, 40=26-8-0, 41=26-8-0,  
42=26-8-0, 43=26-8-0, 44=26-8-0  
Max Horiz 44=100 (LC 15)  
Max Uplift 24=72 (LC 13), 25=122 (LC 22),  
26=20 (LC 17), 27=26 (LC 17),  
28=24 (LC 17), 29=24 (LC 17),  
30=24 (LC 17), 31=27 (LC 17),  
32=30 (LC 17), 36=29 (LC 16),  
37=27 (LC 16), 38=24 (LC 16),  
39=24 (LC 16), 40=24 (LC 16),  
41=26 (LC 16), 42=18 (LC 16),  
43=122 (LC 22), 44=94 (LC 12)  
Max Grav 24=419 (LC 37), 25=58 (LC 13),  
26=159 (LC 37), 27=149 (LC 2),  
28=146 (LC 37), 29=180 (LC 24),  
30=212 (LC 24), 31=215 (LC 24),  
32=219 (LC 24), 33=214 (LC 24),  
34=165 (LC 33), 35=214 (LC 23),  
36=219 (LC 23), 37=215 (LC 23),  
38=212 (LC 23), 39=180 (LC 23),  
40=146 (LC 36), 41=149 (LC 2),  
42=159 (LC 36), 43=73 (LC 12),  
44=419 (LC 36)

**FORCES** (lb) - Maximum Compression/Maximum Tension  
**TOP CHORD**  
2-44=-403/226, 1-2=0/86, 2-3=-90/70,  
3-4=-42/91, 4-5=-32/93, 5-6=-29/97,  
6-7=-42/117, 7-8=-54/142, 8-9=-66/168,  
9-10=-79/194, 10-11=-92/223, 11-12=-96/228,  
12-13=-96/228, 13-14=-92/223,  
14-15=-79/194, 15-16=-66/168,  
16-17=-54/142, 17-18=-42/117,  
18-19=-29/92, 19-20=-17/81, 20-21=-25/79,  
21-22=-81/52, 22-23=0/86, 22-24=-403/223  
**BOT CHORD**  
43-44=-44/63, 42-43=-44/63, 41-42=-44/63,  
40-41=-44/63, 39-40=-44/63, 38-39=-44/63,  
37-38=-44/63, 36-37=-44/63, 35-36=-44/63,  
33-35=-44/63, 32-33=-44/63, 31-32=-44/63,  
30-31=-44/63, 29-30=-44/63, 28-29=-44/63,  
27-28=-44/63, 26-27=-44/63, 25-26=-44/63,  
24-25=-44/63  
**WEBS**  
12-34=-138/28, 11-35=-187/10,  
10-36=-192/52, 9-37=-189/50, 8-38=-185/45,  
7-39=-154/45, 6-40=-120/45, 5-41=-123/47,  
4-42=-130/51, 3-43=-66/148, 13-33=-187/7,  
14-32=-192/52, 15-31=-189/50,  
16-30=-185/45, 17-29=-154/45,  
18-28=-120/45, 19-27=-123/47,  
20-26=-130/51, 21-25=-50/148

**NOTES**  
1) Unbalanced roof live loads have been considered for this design.

- Wind: ASCE 7-16; Vult=100mph (3-second gust) Vasd=79mph; TCDL=4.2psf; BCDL=6.0psf; h=25ft; Cat. II; Exp C; Enclosed; MWFRS (envelope) exterior zone and C-C Corner(3E) -2-0-0 to 1-0-0, Exterior(2N) 1-0-0 to 13-4-0, Corner(3R) 13-4-0 to 16-4-0, Exterior(2N) 16-4-0 to 28-8-0 zone; cantilever left and right exposed; end vertical left and right exposed; C-C for members and forces & MWFRS for reactions shown; Lumber DOL=1.60 plate grip DOL=1.60
- Truss designed for wind loads in the plane of the truss only. For studs exposed to wind (normal to the face), see Standard Industry Gable End Details as applicable, or consult qualified building designer as per ANSI/TPI 1.
- TCLL: ASCE 7-16; Pr=35.0 psf (roof LL: Lum DOL=1.15 Plate DOL=1.15); Pg=50.0 psf; Pf=34.6 psf (Lum DOL = 1.15 Plate DOL = 1.15); Is=1.0; Rough Cat C; Fully Exp.; Ce=0.9; Cs=1.00; Ct=1.10
- Unbalanced snow loads have been considered for this design.
- This truss has been designed for greater of min roof live load of 12.0 psf or 1.00 times flat roof load of 34.6 psf on overhangs non-concurrent with other live loads



EXPIRES: 12/31/2026  
March 5, 2026

Continued on page 2

**WARNING - Verify design parameters and READ NOTES ON THIS AND INCLUDED MITEK REFERENCE PAGE MII-7473 rev. 1/2/2023 BEFORE USE.**

Design valid for use only with MiTek® connectors. This design is based only upon parameters shown, and is for an individual building component, not a truss system. Before use, the building designer must verify the applicability of design parameters and properly incorporate this design into the overall building design. Bracing indicated is to prevent buckling of individual truss web and/or chord members only. Additional temporary and permanent bracing is always required for stability and to prevent collapse with possible personal injury and property damage. For general guidance regarding the fabrication, storage, delivery, erection and bracing of trusses and truss systems, see **ANSI/TPI1 Quality Criteria and DSB-22** available from Truss Plate Institute (www.tpinst.org) and **BCSI Building Component Safety Information** available from the Structural Building Component Association (www.sbcsc.com)

**MiTek®**

400 Sunrise Ave., Suite 270  
Roseville, CA 95661  
916.755.3571 / MiTek-US.com

Job 5268888	Truss A01	Truss Type Common Supported Gable	Qty 2	Ply 1	Sierra James - Deschutes Bungalow R93029747 Job Reference (optional)
----------------	--------------	--------------------------------------	----------	----------	--

Builders FirstSource (Beaverton, OR), Beaverton, OR - 97005,

Run: 8.83 S Jan 22 2026 Print: 8.830 S Jan 22 2026 MiTek Industries, Inc. Thu Mar 05 14:24:21  
ID:qNMG4Vqyil442lBssEDP12zkT7q-RfC?PsB70Hq3NSgPqnL8w3uITXbGKWrcDoi7J4zJC?f

Page: 2

- 7) All plates are 2x4 (||) MT20 unless otherwise indicated.
- 8) Gable requires continuous bottom chord bearing.
- 9) Truss to be fully sheathed from one face or securely braced against lateral movement (i.e. diagonal web).
- 10) Gable studs spaced at 1-4-0 oc.
- 11) This truss has been designed for a 10.0 psf bottom chord live load nonconcurrent with any other live loads.
- 12) \* This truss has been designed for a live load of 20.0psf on the bottom chord in all areas where a rectangle 3-06-00 tall by 2-00-00 wide will fit between the bottom chord and any other members.
- 13) Provide mechanical connection (by others) of truss to bearing plate capable of withstanding 94 lb uplift at joint 44, 72 lb uplift at joint 24, 29 lb uplift at joint 36, 27 lb uplift at joint 37, 24 lb uplift at joint 38, 24 lb uplift at joint 39, 24 lb uplift at joint 40, 26 lb uplift at joint 41, 18 lb uplift at joint 42, 122 lb uplift at joint 43, 30 lb uplift at joint 32, 27 lb uplift at joint 31, 24 lb uplift at joint 30, 24 lb uplift at joint 29, 24 lb uplift at joint 28, 26 lb uplift at joint 27, 20 lb uplift at joint 26 and 122 lb uplift at joint 25.

LOAD CASE(S) Standard

**Not for Construction**  
 These plans are licensed by the City of Bend for permitting within the Bend City Limits.  
 For use of these plans, apply for permits directly with the City of Bend.

**⚠ WARNING - Verify design parameters and READ NOTES ON THIS AND INCLUDED MITEK REFERENCE PAGE MII-7473 rev. 1/2/2023 BEFORE USE.**

Design valid for use only with MiTek® connectors. This design is based only upon parameters shown, and is for an individual building component, not a truss system. Before use, the building designer must verify the applicability of design parameters and properly incorporate this design into the overall building design. Bracing indicated is to prevent buckling of individual truss web and/or chord members only. Additional temporary and permanent bracing is always required for stability and to prevent collapse with possible personal injury and property damage. For general guidance regarding the fabrication, storage, delivery, erection and bracing of trusses and truss systems, see **ANSI/TPI1 Quality Criteria and DSB-22** available from Truss Plate Institute ([www.tpinst.org](http://www.tpinst.org)) and **BCSI Building Component Safety Information** available from the Structural Building Component Association ([www.sbcsccomponents.com](http://www.sbcsccomponents.com))

**MiTek®**

400 Sunrise Ave., Suite 270  
Roseville, CA 95661  
916.755.3571 / MiTek-US.com

Job 5268888	Truss A02	Truss Type Common	Qty 4	Ply 1	Sierra James - Deschutes Bungalow Job Reference (optional)	R93029748
----------------	--------------	----------------------	----------	----------	---	-----------

Builders FirstSource (Beaverton, OR), Beaverton, OR - 97005,

Run: 8.83 S Jan 22 2026 Print: 8.830 S Jan 22 2026 MiTek Industries, Inc. Thu Mar 05 14:24:23  
ID:4eTW6CLwZVWzLz7tmUVG6zKT79-RfC?PsB70Hq3NSgPqnL8w3uITxBGKWrCDoi7J4zJC7f

Page: 1

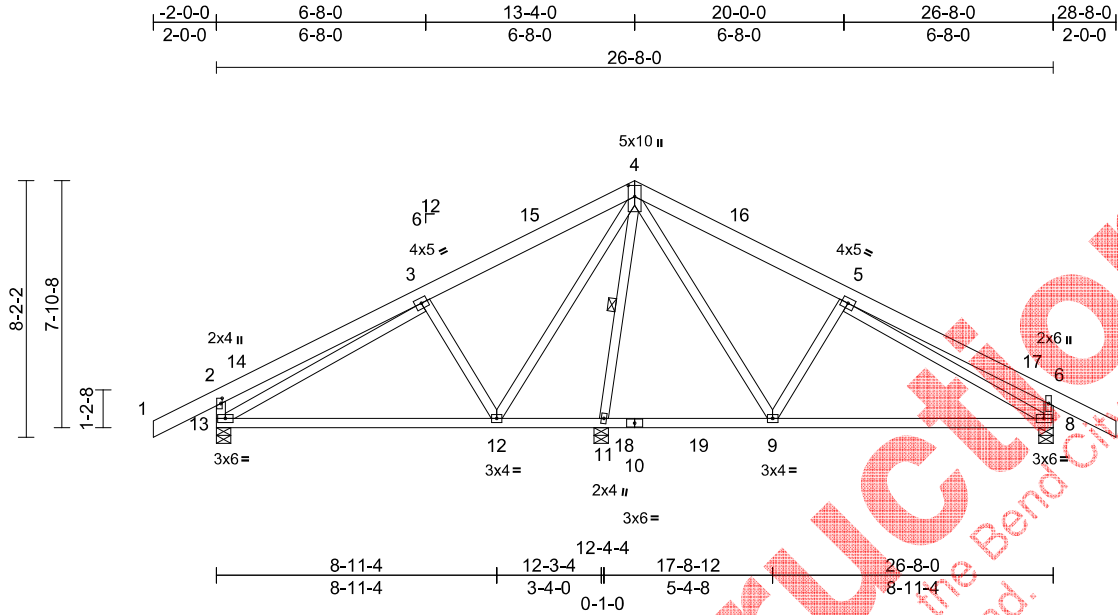

Scale = 1:73.4

Plate Offsets (X, Y): [2:0-2:0,0-0-8], [4:0-4:4,0-2-8]

Loading	(psf)	Spacing	2-0-0	CSI	DEFL	in	(loc)	l/defl	L/d	PLATES	GRIP	
TCLL (roof)	35.0	Plate Grip DOL	1.15	TC	0.45	Vert(LL)	-0.14	12-13	>999	240	MT20	220/195
Snow (Pf/Pg)	34.7/50.0	Lumber DOL	1.15	BC	0.56	Vert(CT)	-0.27	12-13	>534	180		
TCDL	10.0	Rep Stress Incr	YES	WB	0.76	Horz(CT)	0.01	8	n/a	n/a		
BCLL	0.0*	Code	IBC2021/TPI2014	Matrix-SH								
BCDL	10.0											
											Weight: 175 lb	FT = 10%

**LUMBER**

TOP CHORD 2x6 DF No.2  
 BOT CHORD 2x4 DF No.2  
 WEBS 2x4 DF Stud/Std \*Except\* 13-2,8-6:2x4 DF No.2

**BRACING**

TOP CHORD Structural wood sheathing directly applied or 6-0-0 oc purlins, except end verticals.  
 BOT CHORD Rigid ceiling directly applied or 6-0-0 oc bracing.  
 WEBS 1 Row at midpt 4-11

**REACTIONS**

(size) 8=0-5-8, 11=0-5-8, 13=0-5-8  
 Max Horiz 13=100 (LC 15)  
 Max Uplift 8=-109 (LC 17), 11=-61 (LC 16), 13=-87 (LC 16)  
 Max Grav 8=1015 (LC 24), 11=1569 (LC 2), 13=890 (LC 23)

**FORCES**

(lb) - Maximum Compression/Maximum Tension  
 TOP CHORD 1-2=0/86, 2-3=-343/55, 3-4=-509/113, 4-5=-743/134, 5-6=-366/58, 6-7=0/86, 2-13=-552/153, 6-8=-566/153  
 BOT CHORD 12-13=-75/601, 11-12=-203/110, 9-11=-30/102, 8-9=-30/796  
 WEBS 3-13=-539/72, 5-8=-746/70, 3-12=-694/196, 4-12=-78/863, 4-9=-70/872, 5-9=-667/191, 4-11=-1531/90

**NOTES**

1) Unbalanced roof live loads have been considered for this design.

- Wind: ASCE 7-16; Vult=100mph (3-second gust) Vasd=79mph; TCCL=4.2psf; BCDL=6.0psf; h=25ft; Cat. II; Exp C; Enclosed; MWFRS (envelope) exterior zone and C-C Exterior(2E) 2-0-0 to 1-0-0, Interior (1) 1-0-0 to 13-4-0, Exterior(2R) 13-4-0 to 16-4-0, Interior (1) 16-4-0 to 28-8-0 zone; cantilever left and right exposed; end vertical left and right exposed; C-C for members and forces & MWFRS for reactions shown; Lumber DOL=1.60 plate grip DOL=1.60
- TCLL: ASCE 7-16; Pr=35.0 psf (roof LL: Lum DOL=1.15 Plate DOL=1.15); Pg=50.0 psf; Pf=34.6 psf (Lum DOL = 1.15 Plate DOL = 1.15); Is=1.0; Rough Cat C; Fully Exp.; Ce=0.9; Cs=1.00; Cf=1.10
- Unbalanced snow loads have been considered for this design.
- This truss has been designed for greater of min roof live load of 12.0 psf or 1.00 times flat roof load of 34.6 psf on overhangs non-concurrent with other live loads.
- This truss has been designed for a 10.0 psf bottom chord live load nonconcurrent with any other live loads.
- This truss has been designed for a live load of 20.0psf on the bottom chord in all areas where a rectangle 3-06-00 tall by 2-00-00 wide will fit between the bottom chord and any other members, with BCDL = 10.0psf.
- Provide mechanical connection (by others) of truss to bearing plate capable of withstanding 87 lb uplift at joint 13, 109 lb uplift at joint 8 and 61 lb uplift at joint 11.

**LOAD CASE(S)** Standard



EXPIRES: 12/31/2026  
 March 5, 2026

**WARNING - Verify design parameters and READ NOTES ON THIS AND INCLUDED MITEK REFERENCE PAGE MII-7473 rev. 1/2/2023 BEFORE USE.**

Design valid for use only with MiTek® connectors. This design is based only upon parameters shown, and is for an individual building component, not a truss system. Before use, the building designer must verify the applicability of design parameters and properly incorporate this design into the overall building design. Bracing indicated is to prevent buckling of individual truss web and/or chord members only. Additional temporary and permanent bracing is always required for stability and to prevent collapse with possible personal injury and property damage. For general guidance regarding the fabrication, storage, delivery, erection and bracing of trusses and truss systems, see **ANSI/TPI1 Quality Criteria and DSB-22** available from Truss Plate Institute (www.tpin.org) and **BCSI Building Component Safety Information** available from the Structural Building Component Association (www.sbccomponents.com)

**MiTek®**

400 Sunrise Ave., Suite 270  
 Roseville, CA 95661  
 916.755.3571 / MiTek-US.com

Job 5268888	Truss A03	Truss Type Roof Special Structural Gable	Qty 1	Ply 1	Sierra James - Deschutes Bungalow Job Reference (optional)	R93029749
----------------	--------------	---	----------	----------	---	-----------

Builders FirstSource (Beaverton, OR), Beaverton, OR - 97005,

Run: 8.83 S Jan 22 2026 Print: 8.830 S Jan 22 2026 MiTek Industries, Inc. Thu Mar 05 14:24:23  
ID:schOvFlv\_f\_n7X5n4p4fI3zkT4e-RfC?PsB70Hq3NSgPqnl8w3u1TXbGKWvCDoi7J4zJC?f

Page: 1

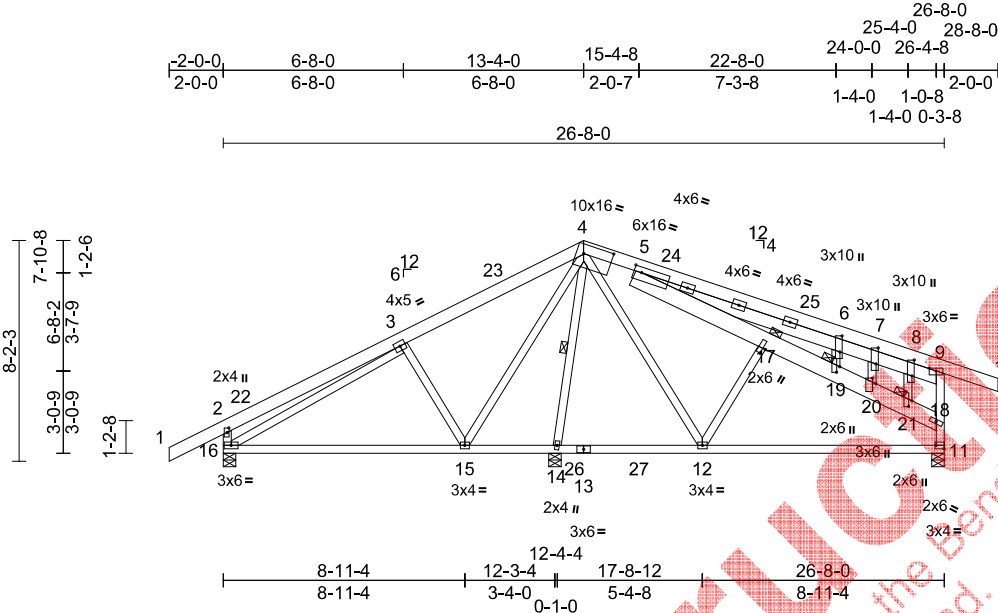

Scale = 1:85.2

Plate Offsets (X, Y): [2:0-2-0,0-0-12], [4:1-0-12,0-4-0], [5:0-3-8,0-2-8], [6:0-7-1,0-1-0], [7:0-7-1,0-1-0], [8:0-7-1,0-1-0], [9:0-3-0,0-1-4], [11:Edge,0-1-8], [17:0-2-11,0-1-4], [19:0-2-7,0-1-8], [20:0-2-9,0-1-8], [21:0-2-7,0-1-8]

Loading	(psf)	Spacing	2-0-0	CSI	DEFL	in	(loc)	l/defl	L/d	PLATES	GRIP	
TCLL (roof)	35.0	Plate Grip DOL	1.15	TC	0.62	Vert(LL)	-0.14	15-16	>999	240	MT20	220/195
Snow (Pf/Pg)	34.7/50.0	Lumber DOL	1.15	BC	0.51	Vert(CT)	-0.27	15-16	>532	180		
TCDL	10.0	Rep Stress Incr	YES	WB	0.53	Horz(CT)	0.01	11	n/a	n/a		
BCLL	0.0*	Code	IBC2021/TPI2014	Matrix-SH								
BCDL	10.0											
											Weight: 229 lb	FT = 10%

LUMBER	
TOP CHORD	2x6 DF No.2
BOT CHORD	2x4 DF No.2
WEBS	2x4 DF Stud/Std *Except* 16-2,11-9:2x4 DF No.2, 5-18:2x8 DF No.2
BRACING	
TOP CHORD	Structural wood sheathing directly applied or 6-0-0 oc purlins, except end verticals.
BOT CHORD	Rigid ceiling directly applied or 6-0-0 oc bracing, Except: 10-0-0 oc bracing: 11-12.
WEBS	1 Row at midpt 4-14
JOINTS	1 Brace at Jt(s): 17, 19, 21
REACTIONS	
(size)	11=0-5-8, 14=0-5-8, 16=0-5-8
Max Horiz	16=100 (LC 14)
Max Uplift	11=-120 (LC 13), 14=-92 (LC 13), 16=-90 (LC 16)
Max Grav	11=879 (LC 24), 14=1813 (LC 2), 16=825 (LC 23)
FORCES	
(lb) - Maximum Compression/Maximum Tension	
TOP CHORD	1-2=0/86, 2-3=-331/60, 3-4=-389/345, 4-5=-193/140, 5-6=-52/246, 6-7=-36/340, 7-8=-23/115, 8-9=-10/121, 9-10=0/61, 2-16=-549/198, 11-18=-786/176, 9-18=-474/174
BOT CHORD	15-16=-132/497, 14-15=-463/108, 12-14=-233/93, 11-12=-17/435
WEBS	3-15=-696/193, 12-17=-576/141, 3-16=-426/249, 4-15=-75/864, 4-12=-17/780, 4-14=-1771/216, 5-17=-401/3, 17-19=-433/13, 19-20=-906/127, 20-21=-651/69, 18-21=-660/72, 6-19=-1131/285, 7-20=-146/595, 8-21=-21/18

NOTES

- Unbalanced roof live loads have been considered for this design.
- Wind: ASCE 7-16; Vult=100mph (3-second gust) Vasd=79mph; TCDL=4.2psf; BCDL=6.0psf; h=25ft; Cat. II; Exp C; Enclosed; MWFRS (envelope) exterior zone and C-C Exterior(2E) -2-0-0 to 1-0-0, Interior (1) 1-0-0 to 13-4-1, Exterior(2R) 13-4-1 to 16-4-1, Interior (1) 16-4-1 to 28-8-0 zone; cantilever left and right exposed; end vertical left and right exposed; C-C for members and forces & MWFRS for reactions shown; Lumber DOL=1.60 plate grip DOL=1.60
- Truss designed for wind loads in the plane of the truss only. For studs exposed to wind (normal to the face), see Standard Industry Gable End Details as applicable, or consult qualified building designer as per ANSI/TPI 1.
- TCLL: ASCE 7-16; Pr=35.0 psf (roof LL: Lum DOL=1.15 Plate DOL=1.15); Pg=50.0 psf; Pf=34.6 psf (Lum DOL = 1.15 Plate DOL = 1.15); Is=1.0; Rough Cat C; Fully Exp.; Ce=0.9; Cs=1.00; Ct=1.10
- Unbalanced snow loads have been considered for this design.
- This truss has been designed for greater of min roof live load of 12.0 psf or 1.00 times flat roof load of 34.6 psf on overhangs non-concurrent with other live loads.
- Truss to be fully sheathed from one face or securely braced against lateral movement (i.e. diagonal web).
- Gable studs spaced at 2-0-0 oc.
- This truss has been designed for a 10.0 psf bottom chord live load nonconcurrent with any other live loads.
- \* This truss has been designed for a live load of 20.0psf on the bottom chord in all areas where a rectangle 3-06-00 tall by 2-00-00 wide will fit between the bottom chord and any other members, with BCDL = 10.0psf.
- Provide mechanical connection (by others) of truss to bearing plate capable of withstanding 120 lb uplift at joint 11, 90 lb uplift at joint 16 and 92 lb uplift at joint 14.

LOAD CASE(S) Standard



EXPIRES: 12/31/2026  
March 5, 2026

**WARNING - Verify design parameters and READ NOTES ON THIS AND INCLUDED MITEK REFERENCE PAGE MII-7473 rev. 1/2/2023 BEFORE USE.**

Design valid for use only with MiTek® connectors. This design is based only upon parameters shown, and is for an individual building component, not a truss system. Before use, the building designer must verify the applicability of design parameters and properly incorporate this design into the overall building design. Bracing indicated is to prevent buckling of individual truss web and/or chord members only. Additional temporary and permanent bracing is always required for stability and to prevent collapse with possible personal injury and property damage. For general guidance regarding the fabrication, storage, delivery, erection and bracing of trusses and truss systems, see **ANSI/TPI1 Quality Criteria and DSB-22** available from Truss Plate Institute (www.tpin.org) and **BCSI Building Component Safety Information** available from the Structural Building Component Association (www.sbccomponents.com)

**MiTek®**

400 Sunrise Ave., Suite 270  
Roseville, CA 95661  
916.755.3571 / MiTek-US.com

Job 5268888	Truss A04	Truss Type Roof Special	Qty 1	Ply 1	Sierra James - Deschutes Bungalow Job Reference (optional)	R93029750
----------------	--------------	----------------------------	----------	----------	---	-----------

Builders FirstSource (Beaverton, OR), Beaverton, OR - 97005,

Run: 8.83 S Jan 22 2026 Print: 8.830 S Jan 22 2026 MiTek Industries, Inc. Thu Mar 05 14:24:24  
ID:ofA0UHRCTKv3Lx7S8unQZzkT5x-RfC?PsB70Hq3NSgPqnl8w3uITXbGKwRCDoi7J4zJC?f

Page: 1

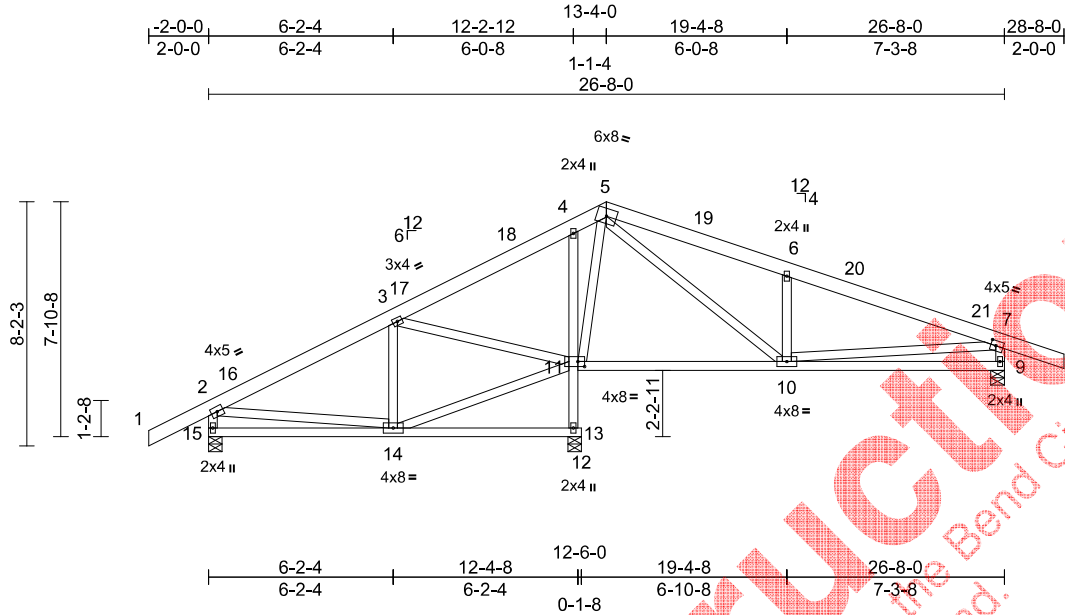

Scale = 1:77.2

Plate Offsets (X, Y): [7:0-2-0,0-2-0], [11:0-2-12,0-2-0]

Loading	(psf)	Spacing	2-0-0	CSI	DEFL	in	(loc)	l/defl	L/d	PLATES	GRIP	
TCLL (roof)	35.0	Plate Grip DOL	1.15	TC	0.36	Vert(LL)	-0.05	10-11	>999	240	MT20	220/195
Snow (Pf/Pg)	34.7/50.0	Lumber DOL	1.15	BC	0.36	Vert(CT)	-0.10	10-11	>999	180		
TCDL	10.0	Rep Stress Incr	YES	WB	0.60	Horz(CT)	0.00	9	n/a	n/a		
BCLL	0.0*	Code	IBC2021/TPI2014	Matrix-SH								
BCDL	10.0											
											Weight: 178 lb	FT = 10%

**LUMBER**

TOP CHORD 2x6 DF No.2  
 BOT CHORD 2x4 DF No.2 \*Except\* 13-4:2x4 DF Stud/Std  
 WEBS 2x4 DF Stud/Std \*Except\* 15-2,9-7:2x4 DF No.2

**BRACING**

TOP CHORD Structural wood sheathing directly applied or 6-0-0 oc purlins, except end verticals.  
 BOT CHORD Rigid ceiling directly applied or 6-0-0 oc bracing. Except:  
 4-4-0 oc bracing: 11-13

**REACTIONS**

(size) 9=0-5-8, 13=0-5-8, 15=0-5-8  
 Max Horiz 15=123 (LC 16)  
 Max Uplift 9=-143 (LC 13), 13=-75 (LC 16), 15=-76 (LC 16)  
 Max Grav 9=1003 (LC 24), 13=1671 (LC 2), 15=810 (LC 23)

**FORCES**

(lb) - Maximum Compression/Maximum Tension  
 TOP CHORD 1-2=0/86, 2-3=-671/60, 3-4=0/445, 4-5=0/299, 5-6=-1181/171, 6-7=-1145/98, 7-8=0/61, 2-15=-755/206, 7-9=-936/219  
 BOT CHORD 14-15=-116/141, 13-14=0/9, 12-13=0/0, 11-13=-1610/180, 4-11=-780/140, 10-11=-156/86, 9-10=-19/239  
 WEBS 3-14=-12/177, 11-14=-92/527, 5-11=-1087/67, 2-14=0/420, 7-10=-26/756, 3-11=-753/119, 6-10=-835/187, 5-10=-130/1363

**NOTES**

1) Unbalanced roof live loads have been considered for this design.

- Wind: ASCE 7-16; Vult=100mph (3-second gust) Vasd=79mph; TCDL=4.2psf; BCDL=6.0psf; h=25ft; Cat. II; Exp C; Enclosed; MWFRS (envelope) exterior zone and C-C Exterior(2E) -2-0-0 to 1-0-0; Interior (1) 1-0-0 to 13-4-1; Exterior(2R) 13-4-1 to 16-4-1; Interior (1) 16-4-1 to 28-8-0 zone; cantilever left and right exposed; end vertical left and right exposed; C-C for members and forces & MWFRS for reactions shown; Lumber DOL=1.60 plate grip DOL=1.60
- TCLL: ASCE 7-16; Pr=35.0 psf (roof LL: Lum DOL=1.15 Plate DOL=1.15); Pg=50.0 psf; Pf=34.6 psf (Lum DOL = 1.15 Plate DOL = 1.15); Is=1.0; Rough Cat C; Fully Exp.; Ce=0.9; Cs=1.00; Cf=1.10
- Unbalanced snow loads have been considered for this design.
- This truss has been designed for greater of min roof live load of 12.0 psf or 1.00 times flat roof load of 34.6 psf on overhangs non-concurrent with other live loads.
- This truss has been designed for a 10.0 psf bottom chord live load nonconcurrent with any other live loads.
- This truss has been designed for a live load of 20.0psf on the bottom chord in all areas where a rectangle 3-06-00 tall by 2-00-00 wide will fit between the bottom chord and any other members.
- Provide mechanical connection (by others) of truss to bearing plate capable of withstanding 76 lb uplift at joint 15, 75 lb uplift at joint 13 and 143 lb uplift at joint 9.

**LOAD CASE(S)** Standard



EXPIRES: 12/31/2026  
 March 5, 2026

**WARNING - Verify design parameters and READ NOTES ON THIS AND INCLUDED MITEK REFERENCE PAGE MII-7473 rev. 1/2/2023 BEFORE USE.**

Design valid for use only with MiTek® connectors. This design is based only upon parameters shown, and is for an individual building component, not a truss system. Before use, the building designer must verify the applicability of design parameters and properly incorporate this design into the overall building design. Bracing indicated is to prevent buckling of individual truss web and/or chord members only. Additional temporary and permanent bracing is always required for stability and to prevent collapse with possible personal injury and property damage. For general guidance regarding the fabrication, storage, delivery, erection and bracing of trusses and truss systems, see **ANSI/TPI1 Quality Criteria and DSB-22** available from Truss Plate Institute (www.tpin.org) and **BCSI Building Component Safety Information** available from the Structural Building Component Association (www.sbcsccomponents.com)

**MiTek®**

400 Sunrise Ave., Suite 270  
 Roseville, CA 95661  
 916.755.3571 / MiTek-US.com

Job 5268888	Truss A05	Truss Type Roof Special	Qty 8	Ply 1	Sierra James - Deschutes Bungalow Job Reference (optional)	R93029751
----------------	--------------	----------------------------	----------	----------	---	-----------

Builders FirstSource (Beaverton, OR), Beaverton, OR - 97005,

Run: 8.83 S Jan 22 2026 Print: 8.830 S Jan 22 2026 MiTek Industries, Inc. Thu Mar 05 14:24:24  
ID:Ldq2p1wXPyLm4l3s?pRP1zkT3q-RfC?PsB70Hq3NSgPqnl8w3ulTXbGKwRCDoi7J4zJC?F

Page: 1

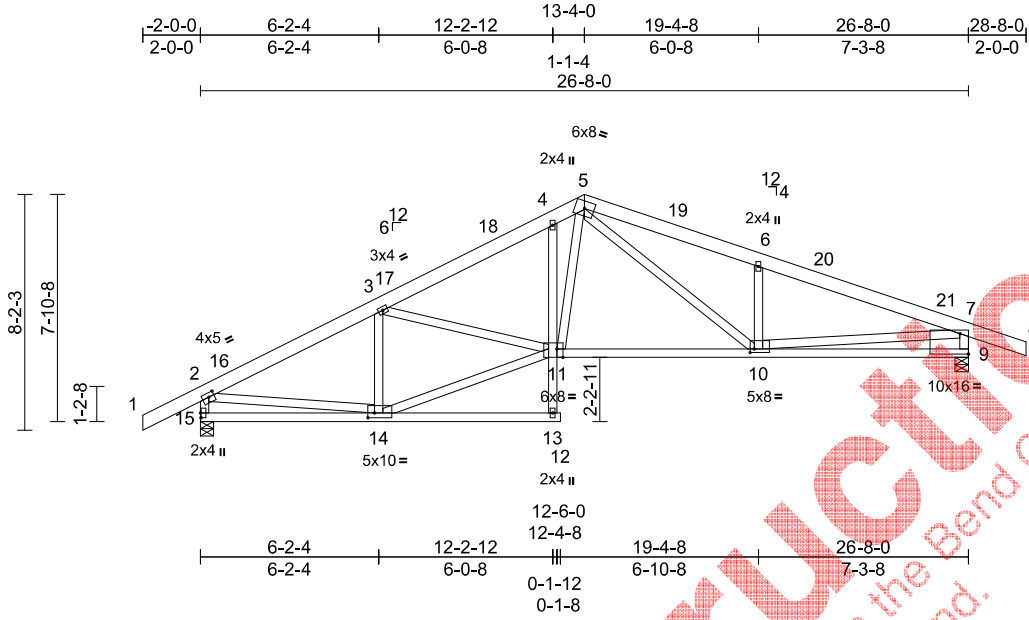

Scale = 1:80

Plate Offsets (X, Y): [2:0-2-4,0-1-12], [9:Edge,0-8-8], [10:0-1-12,0-1-8], [11:0-2-8,Edge], [14:0-2-12,0-2-0], [15:0-2-0,0-0-4]

Loading	(psf)	Spacing	2-0-0	CSI	DEFL	in	(loc)	l/defl	L/d	PLATES	GRIP	
TCLL (roof)	35.0	Plate Grip DOL	1.15	TC	0.46	Vert(LL)	-0.11	10-11	>999	240	MT20	220/195
Snow (Pf/Pg)	34.7/50.0	Lumber DOL	1.15	BC	0.52	Vert(CT)	-0.23	10-11	>999	180		
TCDL	10.0	Rep Stress Incr	YES	WB	0.94	Horz(CT)	0.06	9	n/a	n/a		
BCLL	0.0*	Code	IBC2021/TPI2014	Matrix-SH								
BCDL	10.0											
											Weight: 178 lb	FT = 10%

**LUMBER**

TOP CHORD 2x6 DF No.2  
 BOT CHORD 2x4 DF No.2  
 WEBS 2x4 DF Stud/Std \*Except\* 15-2,9-7:2x4 DF No.2

**BRACING**

TOP CHORD Structural wood sheathing directly applied or 4-3-2 oc purlins, except end verticals.  
 BOT CHORD Rigid ceiling directly applied or 10-0-0 oc bracing.

**REACTIONS**

(size) 9=0-5-8, 15=0-5-8  
 Max Horiz 15=123 (LC 16)  
 Max Uplift 9=-161 (LC 13), 15=-118 (LC 16)  
 Max Grav 9=1697 (LC 24), 15=1688 (LC 23)

**FORCES**

(lb) - Maximum Compression/Maximum Tension  
 TOP CHORD 1-2=0/86, 2-3=-2191/187, 3-4=-2384/254, 4-5=-2277/313, 5-6=-2752/305, 6-7=-2732/234, 7-8=0/61, 2-15=-1628/275, 7-9=-1625/285  
 BOT CHORD 14-15=-122/226, 13-14=0/15, 12-13=0/0, 10-11=-101/1806, 9-10=-23/376  
 WEBS 3-14=-771/157, 2-14=-98/1684, 11-14=-175/1952, 5-11=-142/1364, 6-10=-786/186, 3-11=-6/408, 7-10=-157/2127, 5-10=-119/1039, 11-13=0/106, 4-11=-601/131

**NOTES**

1) Unbalanced roof live loads have been considered for this design.

- Wind: ASCE 7-16; Vult=100mph (3-second gust) Vasd=79mph; TCDL=4.2psf; BCDL=6.0psf; h=25ft; Cat. II; Exp C; Enclosed; MWFRS (envelope) exterior zone and C-C Exterior(2E) -2-0-0 to 1-0-0, Interior (1) 1-0-0 to 13-4-1, Exterior(2R) 13-4-1 to 16-4-1, Interior (1) 16-4-1 to 28-8-0 zone; cantilever left and right exposed; end vertical left and right exposed; C-C for members and forces & MWFRS for reactions shown; Lumber DOL=1.60 plate grip DOL=1.60
- TCLL: ASCE 7-16; Pr=35.0 psf (roof LL: Lum DOL=1.15 Plate DOL=1.15); Pg=50.0 psf; Pf=34.6 psf (Lum DOL = 1.15 Plate DOL = 1.15); Is=1.0; Rough Cat C; Fully Exp.; Ce=0.9; Cs=1.00; Ct=1.10
- Unbalanced snow loads have been considered for this design.
- This truss has been designed for greater of min roof live load of 12.0 psf or 1.00 times flat roof load of 34.6 psf on overhangs non-concurrent with other live loads.
- This truss has been designed for a 10.0 psf bottom chord live load nonconcurrent with any other live loads.
- This truss has been designed for a live load of 20.0psf on the bottom chord in all areas where a rectangle 3-06-00 tall by 2-00-00 wide will fit between the bottom chord and any other members.
- Provide mechanical connection (by others) of truss to bearing plate capable of withstanding 118 lb uplift at joint 15 and 161 lb uplift at joint 9.

**LOAD CASE(S)** Standard



EXPIRES: 12/31/2026  
 March 5, 2026

**WARNING - Verify design parameters and READ NOTES ON THIS AND INCLUDED MITEK REFERENCE PAGE MII-7473 rev. 1/2/2023 BEFORE USE.**

Design valid for use only with MiTek® connectors. This design is based only upon parameters shown, and is for an individual building component, not a truss system. Before use, the building designer must verify the applicability of design parameters and properly incorporate this design into the overall building design. Bracing indicated is to prevent buckling of individual truss web and/or chord members only. Additional temporary and permanent bracing is always required for stability and to prevent collapse with possible personal injury and property damage. For general guidance regarding the fabrication, storage, delivery, erection and bracing of trusses and truss systems, see **ANSI/TPI1 Quality Criteria and DSB-22** available from Truss Plate Institute (www.tpin.org) and **BCSI Building Component Safety Information** available from the Structural Building Component Association (www.sbcsccomponents.com)

**MiTek®**

400 Sunrise Ave., Suite 270  
 Roseville, CA 95661  
 916.755.3571 / MiTek-US.com



Job 5268888	Truss A07	Truss Type Common	Qty 5	Ply 1	Sierra James - Deschutes Bungalow Job Reference (optional)	R93029753
----------------	--------------	----------------------	----------	----------	---	-----------

Builders FirstSource (Beaverton, OR), Beaverton, OR - 97005,

Run: 8.83 S Jan 22 2026 Print: 8.830 S Jan 22 2026 MiTek Industries, Inc. Thu Mar 05 14:24:25  
ID: bz2?6\_G9G3K?7a8kPspITPRzkt25-RfC?PsB70Hq3NSgPqnlLw3uITxBGKWrCDoi7J4zJC?F

Page: 1

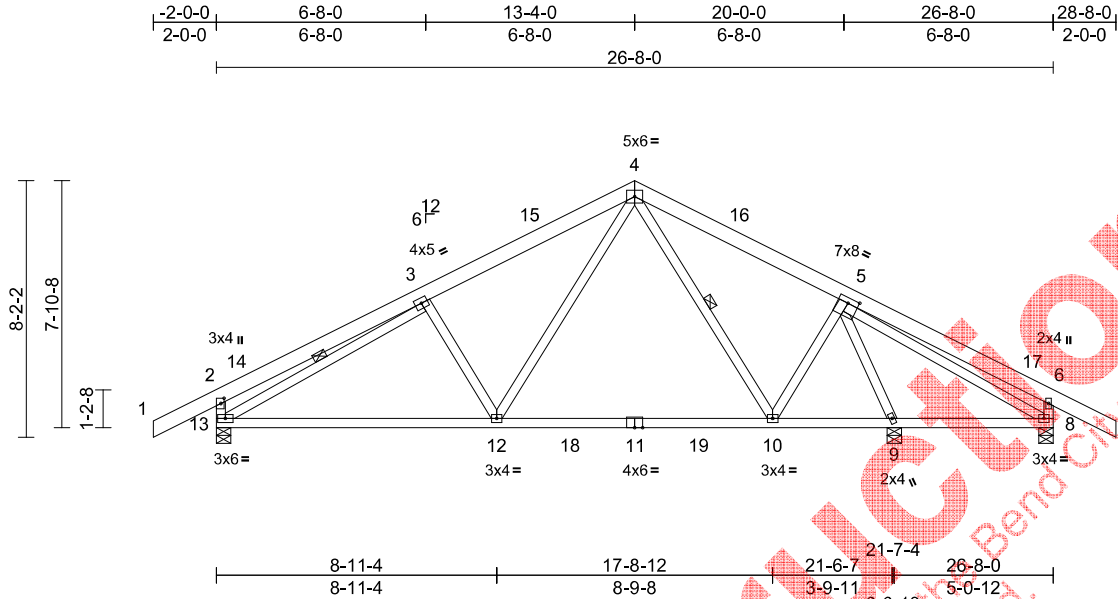

Scale = 1:73.4

Plate Offsets (X, Y): [2:0-2-0,0-1-4], [5:0-4-0,0-2-0]

Loading	(psf)	Spacing	2-0-0	CSI	DEFL	in	(loc)	l/defl	L/d	PLATES	GRIP	
TCLL (roof)	35.0	Plate Grip DOL	1.15	TC	0.52	Vert(LL)	-0.18	10-12	>999	240	MT20	220/195
Snow (Pf/Pg)	34.7/50.0	Lumber DOL	1.15	BC	0.77	Vert(CT)	-0.28	10-12	>909	180		
TCDL	10.0	Rep Stress Incr	YES	WB	0.53	Horz(CT)	0.03	9	n/a	n/a		
BCLL	0.0*	Code	IBC2021/TPI2014	Matrix-SH								
BCDL	10.0											
											Weight: 171 lb	FT = 10%

**LUMBER**

TOP CHORD 2x6 DF No.2  
 BOT CHORD 2x4 DF No.2  
 WEBS 2x4 DF Stud/Std \*Except\* 13-2,8-6:2x4 DF No.2

**BRACING**

TOP CHORD Structural wood sheathing directly applied or 4-11-13 oc purlins, except end verticals.  
 BOT CHORD Rigid ceiling directly applied or 10-0-0 oc bracing, Except:  
 6-0-0 oc bracing: 8-9.  
 WEBS 1 Row at midpt 3-13, 4-10

**REACTIONS**

(size) 8=0-5-8, 9=0-5-8, 13=0-5-8  
 Max Horiz 13=100 (LC 15)  
 Max Uplift 8=-87 (LC 17), 9=-40 (LC 17), 13=-117 (LC 16)  
 Max Grav 8=456 (LC 37), 9=1597 (LC 24), 13=1454 (LC 23)

**FORCES**

(lb) - Maximum Compression/Maximum Tension  
 TOP CHORD 1-2=0/86, 2-3=-432/67, 3-4=-1561/155, 4-5=-906/148, 5-6=-149/167, 6-7=0/86, 2-13=-615/158, 6-8=-463/161  
 BOT CHORD 12-13=-118/1483, 10-12=0/791, 9-10=-4/424, 8-9=-185/49  
 WEBS 3-12=-575/191, 5-10=0/683, 3-13=-1478/103, 4-12=-55/853, 4-10=-462/52, 5-8=-23/247, 5-9=-1603/108

**NOTES**

1) Unbalanced roof live loads have been considered for this design.

- Wind: ASCE 7-16; Vult=100mph (3-second gust) Vasd=79mph; TCDL=4.2psf; BCDL=6.0psf; h=25ft; Cat. II; Exp C; Enclosed; MWFRS (envelope) exterior zone and C-C Exterior(2E) 2-0-0 to 1-0-0, Interior (1) 1-0-0 to 13-4-0, Exterior(2R) 13-4-0 to 16-4-0, Interior (1) 16-4-0 to 28-8-0 zone; cantilever left and right exposed; end vertical left and right exposed; C-C, for members and forces & MWFRS for reactions shown; Lumber DOL=1.60 plate grip DOL=1.60.
- TCLL: ASCE 7-16; Pr=35.0 psf (roof LL: Lum DOL=1.15 Plate DOL=1.15); Pg=50.0 psf; Pf=34.6 psf (Lum DOL = 1.15 Plate DOL = 1.15); Is=1.0; Rough Cat C; Fully Exp.; Ce=0.9; Cs=1.00; Cf=1.10
- Unbalanced snow loads have been considered for this design.
- This truss has been designed for greater of min roof live load of 12.0 psf or 1.00 times flat roof load of 34.6 psf on overhangs non-concurrent with other live loads.
- This truss has been designed for a 10.0 psf bottom chord live load nonconcurrent with any other live loads.
- This truss has been designed for a live load of 20.0psf on the bottom chord in all areas where a rectangle 3-06-00 tall by 2-00-00 wide will fit between the bottom chord and any other members, with BCDL = 10.0psf.
- Provide mechanical connection (by others) of truss to bearing plate capable of withstanding 117 lb uplift at joint 13, 87 lb uplift at joint 8 and 40 lb uplift at joint 9.

LOAD CASE(S) Standard



EXPIRES: 12/31/2026  
 March 5, 2026

**WARNING - Verify design parameters and READ NOTES ON THIS AND INCLUDED MITEK REFERENCE PAGE MII-7473 rev. 1/2/2023 BEFORE USE.**

Design valid for use only with MiTek® connectors. This design is based only upon parameters shown, and is for an individual building component, not a truss system. Before use, the building designer must verify the applicability of design parameters and properly incorporate this design into the overall building design. Bracing indicated is to prevent buckling of individual truss web and/or chord members only. Additional temporary and permanent bracing is always required for stability and to prevent collapse with possible personal injury and property damage. For general guidance regarding the fabrication, storage, delivery, erection and bracing of trusses and truss systems, see **ANSI/TPI1 Quality Criteria and DSB-22** available from Truss Plate Institute (www.tpin.org) and **BCSI Building Component Safety Information** available from the Structural Building Component Association (www.sbccomponents.com)

**MiTek®**

400 Sunrise Ave., Suite 270  
 Roseville, CA 95661  
 916.755.3571 / MiTek-US.com

# Symbols

## PLATE LOCATION AND ORIENTATION



Center plate on joint unless x, y offsets are indicated. Dimensions are in ft-in-sixteenths. Apply plates to both sides of truss and fully embed teeth.

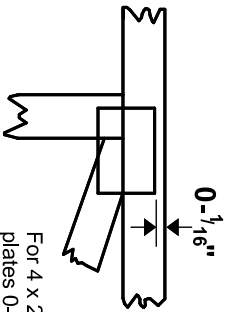

For 4 x 2 orientation, locate plates 0- 1/16\" from outside edge of truss.

This symbol indicates the required direction of slots in connector plates.

\* Plate location details available in MITek software or upon request.

## PLATE SIZE

4 X 4

The first dimension is the plate width measured perpendicular to slots. Second dimension is the length parallel to slots.

## LATERAL BRACING LOCATION



Indicated by symbol shown and/or by text in the bracing section of the output. Use T or I bracing if indicated.

## BEARING

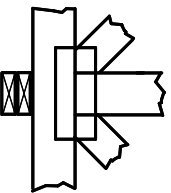

Indicates location where bearings (supports) occur. Icons vary but reaction section indicates joint number/letter where bearings occur. Min size shown is for crushing only.

## Industry Standards:

ANSI/TP1: National Design Specification for Metal Plate Connected Wood Truss Construction.  
DSB-22: Design Standard for Bracing, Building Component Safety Information, Guide to Good Practice for Handling, Installing, Restraining & Bracing of Metal Plate Connected Wood Trusses.

# Numbering System



dimensions shown in ft-in-sixteenths (Drawings not to scale)

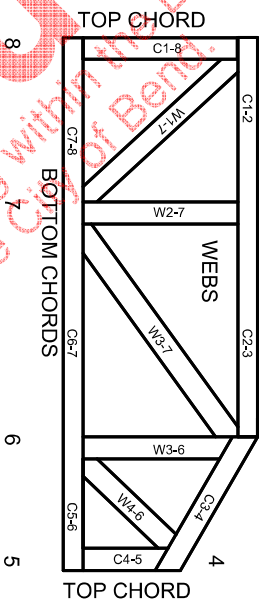

**JOINTS ARE GENERALLY NUMBERED/LETTERED CLOCKWISE AROUND THE TRUSS STARTING AT THE JOINT FARTHEST TO THE LEFT.**

**CHORDS AND WEBS ARE IDENTIFIED BY END JOINT NUMBERS/LETTERS.**

## Product Code Approvals

ICC-ES Reports:

ESR-1988, ESR-2362, ESR-2685, ESR-3282  
ESR-4722, ESL-1388

## Design General Notes

Trusses are designed for wind loads in the plane of the truss unless otherwise shown.

Lumber design values are in accordance with ANSI/TP1 section 6.3. These truss designs rely on lumber values established by others.

© 2023 MITek® All Rights Reserved

# General Safety Notes

## Failure to Follow Could Cause Property Damage or Personal Injury

1. Additional stability bracing for truss system, e.g. diagonal or X-bracing, is always required. See BCSI.
2. Truss bracing must be designed by an engineer. For wide truss spacing, individual lateral braces themselves may require bracing, or alternative Tor I bracing should be considered.
3. Never exceed the design loading shown and never stack materials on inadequately braced trusses.
4. Provide copies of this truss design to the building designer, erection supervisor, property owner and all other interested parties.
5. Cut members to bear tightly against each other.
6. Place plates on each face of truss at each joint and embed fully. Knots and weave at joint locations are regulated by ANSI/TP 1.
7. Design assumes trusses will be suitably protected from the environment in accord with ANSI/TP 1.
8. Unless otherwise noted, moisture content of lumber shall not exceed 19% at time of fabrication.
9. Unless expressly noted, this design is not applicable for use with fire retardant, preservative treated, or green lumber.
10. Camber is a non-structural consideration and is the responsibility of truss fabricator. General practice is to camber for dead load deflection.
11. Plate type, size, orientation and location dimensions indicated are minimum plating requirements.
12. Lumber used shall be of the species and size, and in all respects, equal to or better than that specified.
13. Top chords must be sheathed or purlins provided at spacing indicated on design.
14. Bottom chords require lateral bracing at 10 ft. spacing, or less, if no ceiling is installed, unless otherwise noted.
15. Connections not shown are the responsibility of others.
16. Do not cut or alter truss member or plate without prior approval of an engineer.
17. Install and load vertically unless indicated otherwise.
18. Use of green or treated lumber may pose unacceptable environmental, health or performance risks. Consult with project engineer before use.
19. Review all portions of this design (front, back, words and pictures) before use. Rewriting pictures alone is not sufficient.
20. Design assumes manufacture in accordance with ANSI/TP1 1 Quality Criteria.
21. The design does not take into account any dynamic or other loads other than those expressly stated.

# MITek®

MITek Engineering Reference Sheet: MIL-7473 rev. 1/2/2023

TRIANGLE SHAPE ▲ INDICATES LEFT END ON LAYOUT AND TRUSS DRAWING ON STAMPED ENGINEERING PAGE

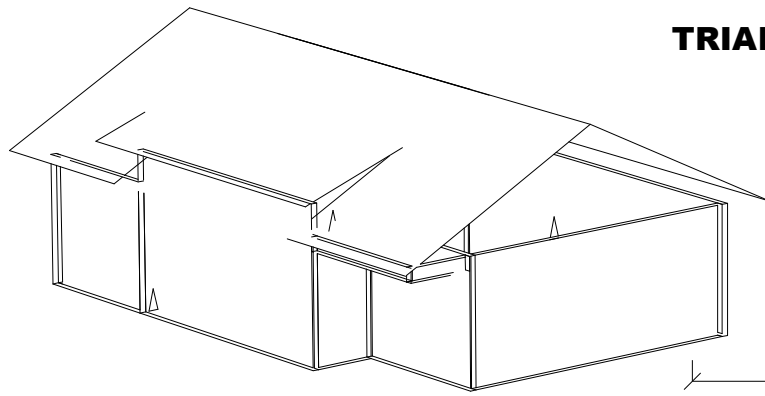

- 16" OC Gable Studs
- 2x6 Top Chords
- 2x6 50/50 Vents & Solids
- 2x10 Solids
- One row @ raised heels
- 1'-2 1/2" OA Heels

- TC LL = 35 Roof / 50 Ground Snow
- TC DL = 10
- BC LL = 0
- BC DL = 10
- Total Load = 55
- Wind Speed = 100 mph
- Exposure = C
- Roof pitch = 4/12 & 6/12
- Overhang = 24"

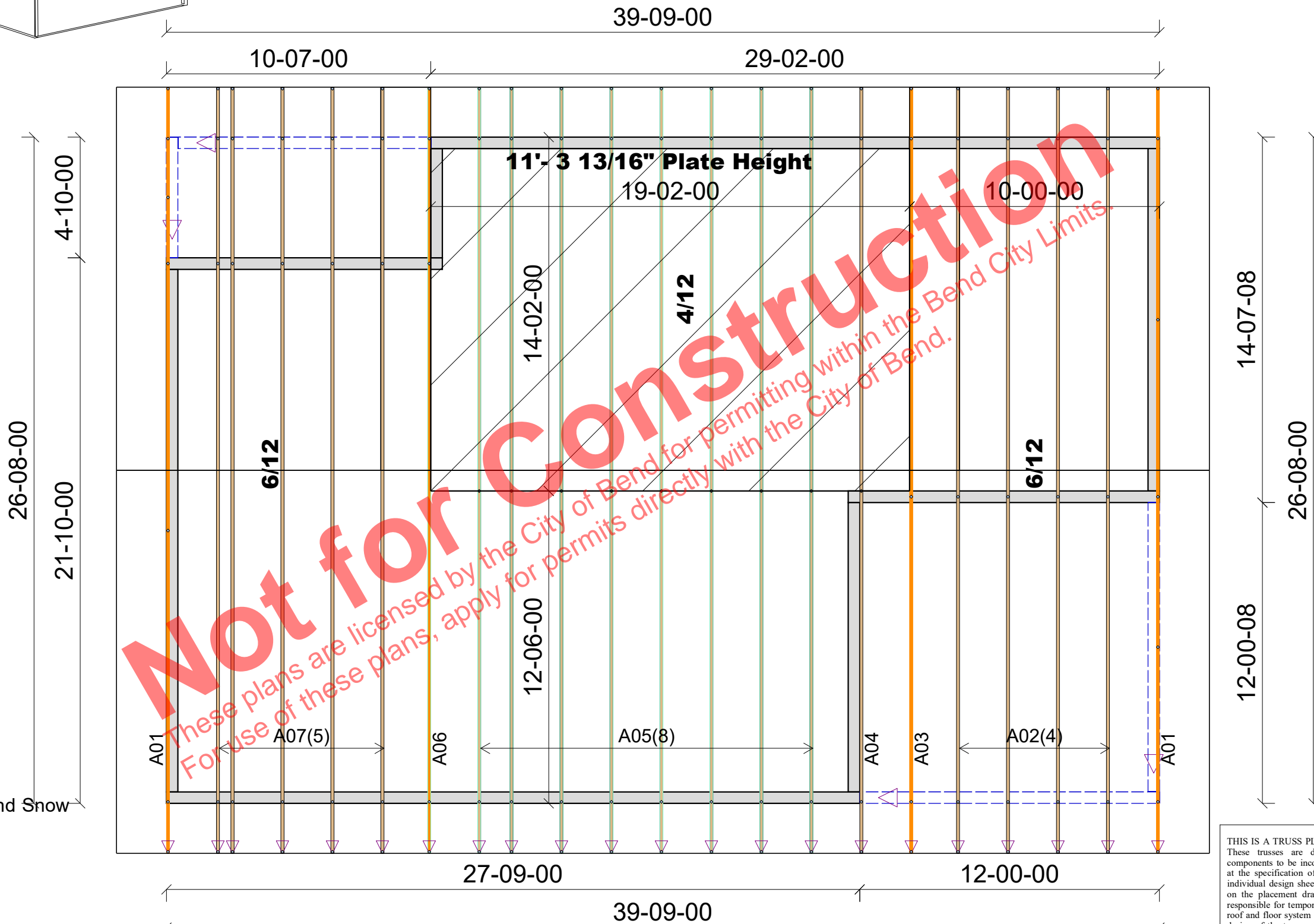

Jurisdiction Stamp

DO NOT CUT, DRILL, NOTCH OR MODIFY TRUSS MEMBERS WITHOUT PRIOR APPROVAL FROM BUILDERS FIRSTSOURCE TRUSS

DATE: 3/5/2026	SCALE: NTS
SALESMAN: Tyler Campbell	PROJECT #: 5268888
DESIGNER: BFS	
SW Washington and Oregon Components Woodland Office: 360-841-5900 Beaverton Office: 971-371-5971	
BUILDER: Sierra James	PROJECT: Deschutes Bungalow
ADDRESS: Bend, OR.	

THIS IS A TRUSS PLACEMENT DIAGRAM ONLY. These trusses are designed as individual building components to be incorporated into the building design at the specification of the building designer. See the individual design sheets for each truss design identified on the placement drawing. The building designer is responsible for temporary and permanent bracing of the roof and floor system and for the overall structure. The design of the truss support structure including headers, beams, walls, and columns is the responsibility of the building designer. For general guidance regarding bracing, consult "Bracing of wood trusses" available from the Truss Plate Institute, 583 D'Onifrio Drive, Madison, WI 53179