

---

**CITY OF BEND STANDARD DRAWINGS**

**Erosion (E)**

---

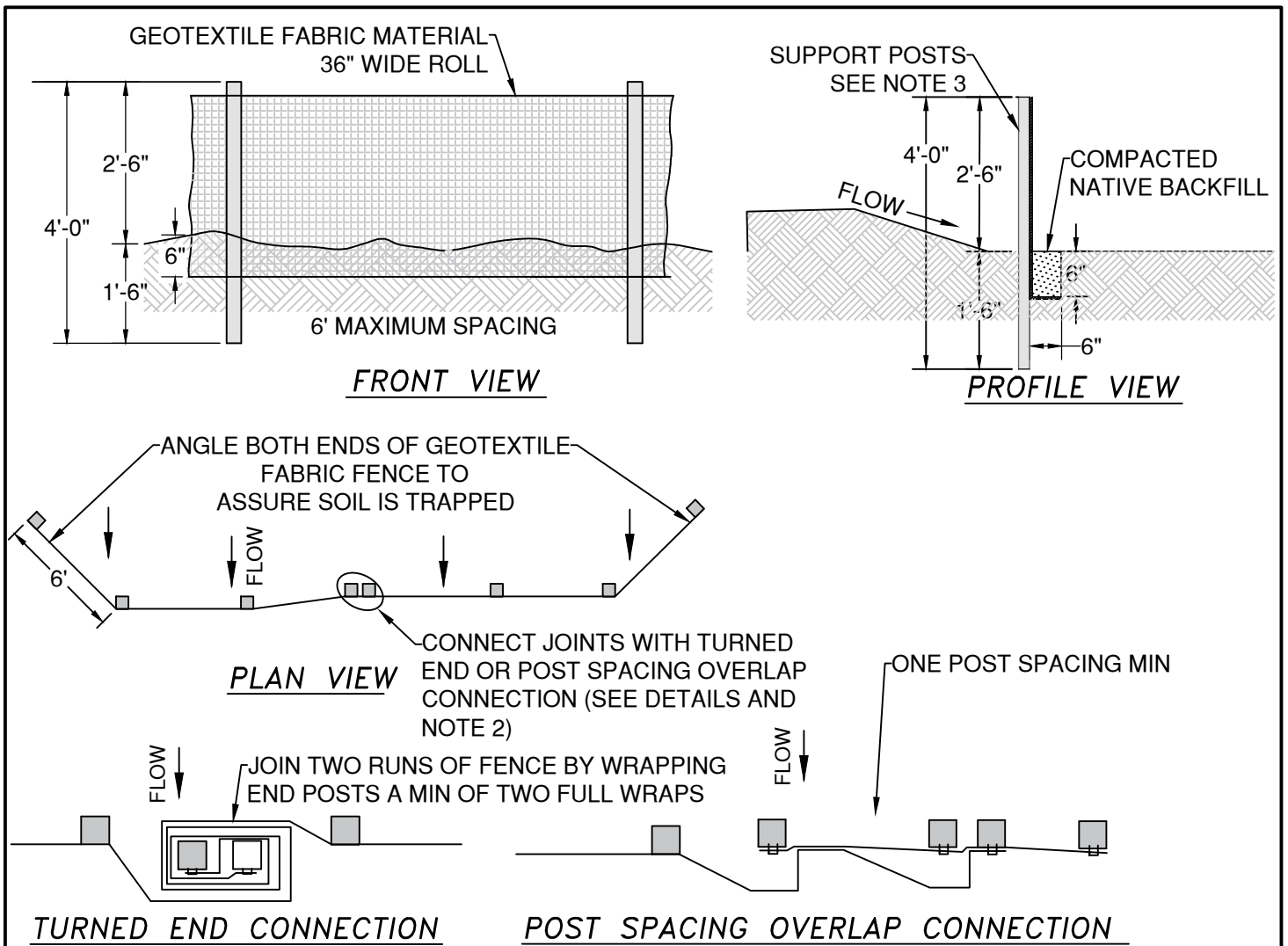

**NOTES:**

1. FABRIC WITHOUT SEWN-IN SLEEVES IS NOT RECOMMENDED. IF USED, INSTALL FENCE POSTS PER MANUFACTURER RECOMMENDATIONS.
2. THE GEOTEXTILE FABRIC SHALL BE PURCHASED IN A CONTINUOUS ROLL CUT TO THE LENGTH OF THE BARRIER TO AVOID USE OF JOINTS. WHEN JOINTS ARE NECESSARY, GEOTEXTILE SHALL BE SPLICED TOGETHER AT A SUPPORT POST UTILIZING A TURNED END OR POST SPACING OVERLAP CONNECTION.
3. THE FENCE POSTS SHALL BE SPACED A MAXIMUM OF 6 FEET APART AND INSTALLED INTO THE GROUND 18 INCHES MIN. FENCE POSTS SHALL BE 2" X 2" FIR, PINE, OR STEEL. THE GEOTEXTILE FABRIC FENCE SHALL BE INSTALLED TO FOLLOW THE SLOPE CONTOURS, TO MAXIMIZE PONDING EFFICIENCY WHERE FEASIBLE.
4. BURY BOTTOM OF THE GEOTEXTILE FABRIC 6 INCHES BELOW GRADE. BACKFILL AND COMPACT.
5. POSTS SHALL BE INSTALLED WITHIN THE SLEEVE ON THE UPHILL SIDE GEOTEXTILE FABRIC.
6. GEOTEXTILE FABRIC FENCE SHALL BE REMOVED WHEN IT HAS SERVED ITS USEFUL PURPOSE, BUT NOT BEFORE THE UPSLOPE AREA HAS BEEN PERMANENTLY PROTECTED AND STABILIZED.
7. GEOTEXTILE FABRIC FENCES SHALL BE INSPECTED BY APPLICANT/CONTRACTOR AFTER EACH RAIN OR SNOW EVENT AND AT LEAST DAILY DURING PROLONGED RAINFALL. ANY REQUIRED REPAIRS SHALL BE MADE IMMEDIATELY.
8. MAXIMUM RECOMMENDED FENCE WIDTH IS 500 FEET. MAXIMUM TRIBUTARY AREA IS 0.25 ACRE PER 100' OF FENCE. MAXIMUM RECOMMENDED SLOPE LENGTH IS 100'.

DRAWN A.J.D. DIV EROSION REV DATE	 <b>CITY OF BEND</b>	<b>CITY OF BEND</b> STANDARD DRAWING 710 NW WALL ST., BEND, OREGON 97701	SCALE NTS DATE 01/31/2022 APPR STD DWG E-1
<b>SEDIMENT FENCE DETAIL</b>			

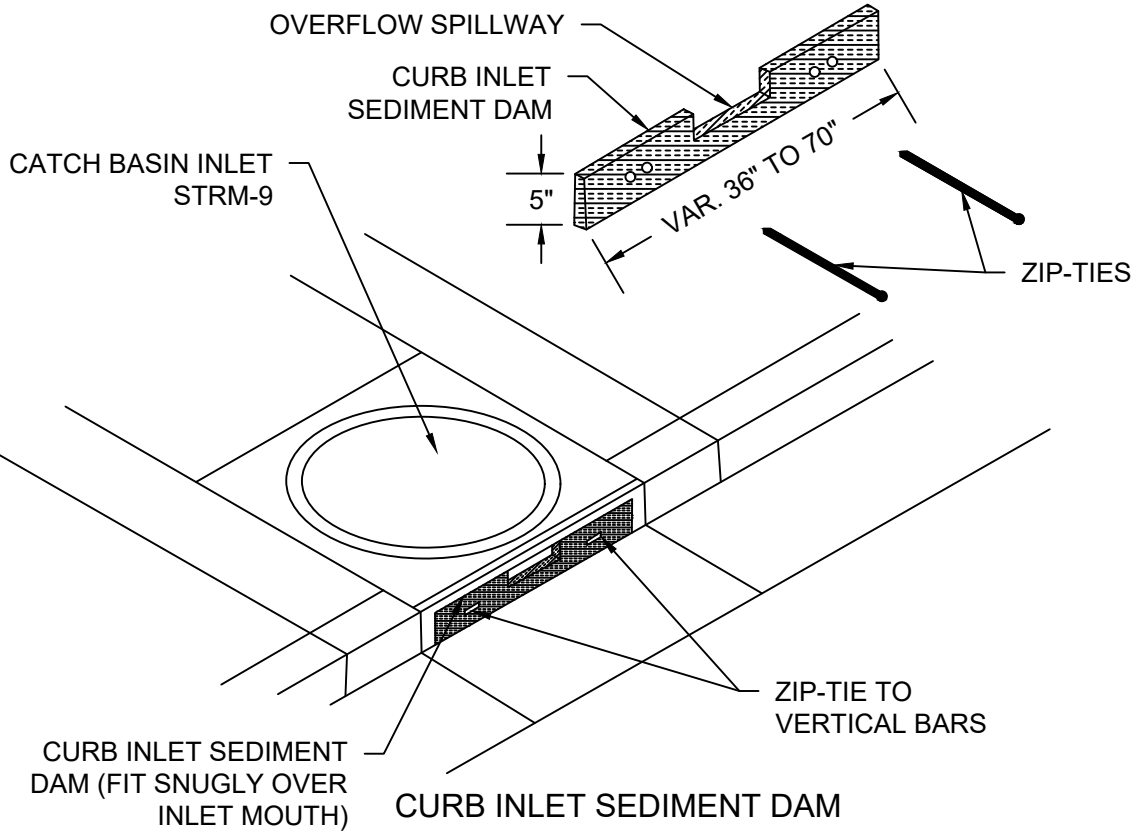

**NOTES:**

1. INSTALL SEDIMENT DAM ACCORDING TO MANUFACTURE'S RECOMMENDATION. ENDS SHALL NOT EXTEND BEYOND THE MOUNT OF THE INLET.
2. SEDIMENT DAMS ARE REQUIRED TO BE ACCOMPANIED BY ADDITIONAL BMPs TO PREVENT THE POTENTIAL OF SEDIMENTS ENTERING PROJECT STORM SYSTEMS.
3. INSPECTION & MAINTENANCE:
  - 3.1. INSPECT DAMS WEEKLY AND DAILY DURING STORM EVENTS.
  - 3.2. CLEAN, OR REPLACE, DAMS WHEN DEBRIS HAS REACH A HEIGHT OF 2 INCHES.
  - 3.3. CONTRACTOR IS RESPONSIBLE FOR REMOVING DAMS AND PROPERLY DISPOSING OF ALL MATERIALS ONCE THE PROJECT HAS BEEN PERMANENTLY STABILIZED.

DRAWN CJH	
DIV EROSION	
REV	DATE



**CITY OF BEND**  
 STANDARD DRAWING  
 710 NW WALL ST., BEND, OREGON 97701

---

**CURB INLET PROTECTION**

SCALE NTS
DATE 11/01/2024
APPR
STD DWG E-2A

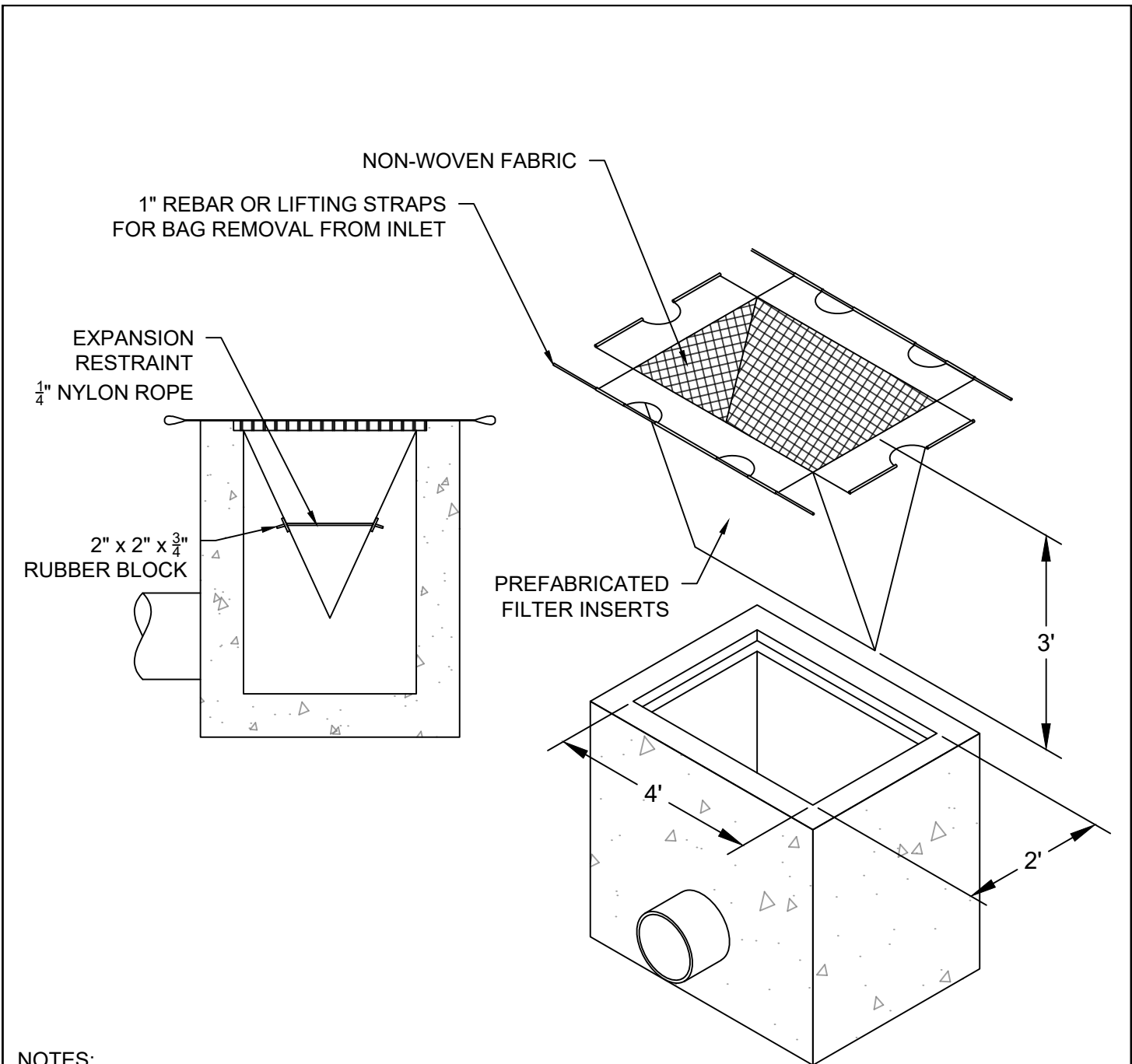

**NOTES:**

1. INSTALL PRE-FABRICATED FILTER INSERTS ACCORDING TO MANUFACTURER'S RECOMMENDATIONS.
2. FIELD FABRICATED INSERTS ARE NOT PERMITTED.
3. PRE-FABRICATED INSERTS WITH A PROVISION FOR OVERFLOW ARE REQUIRED AND ARE TO BE ACCOMPANIED BY ADDITIONAL BMPS TO PREVENT THE POTENTIAL OF SEDIMENTS ENTERING PROJECT STORM SYSTEMS.
4. PAIR WITH THE CURB LINE SEDIMENT ATTENUATEOR (SEE E-2C) AS REQUIRED.
5. INSPECT & MAINTENANCE:
  - 5.1. INSPECT WEEKLY AND DAILY DURING STORM EVENTS.
  - 5.2. CLEAN, OR REPLACE, INSERTS WHEN 50% OF THE SUMP AREA HAS FILLED WITH DEBRIS.
  - 5.3. CONTRACTOR IS RESPONSIBLE FOR REMOVING INSERTS AND PROPERLY DISPOSING OF ALL MATERIALS ONCE THE PROJECT HAS BEEN PERMANENTLY STABILIZED.

DRAWN CJH	 <b>CITY OF BEND</b>	<b>CITY OF BEND</b> STANDARD DRAWING 710 NW WALL ST., BEND, OREGON 97701	SCALE NTS
DIV EROSION			DATE 11/01/2024
REV DATE			APPR
		<b>GRATED INLET PREFABRICATED FILTER INSERT</b>	STD DWG E-2B

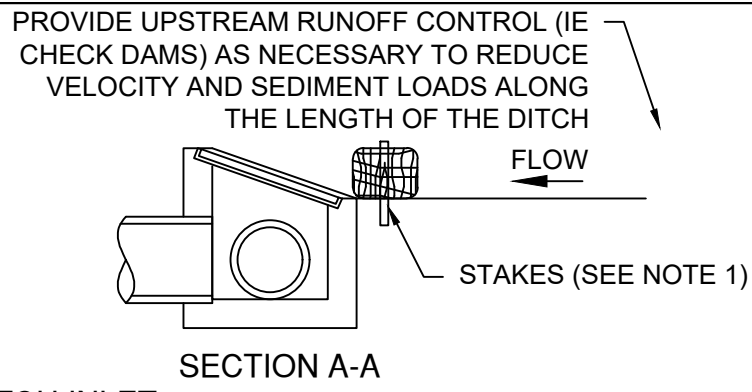
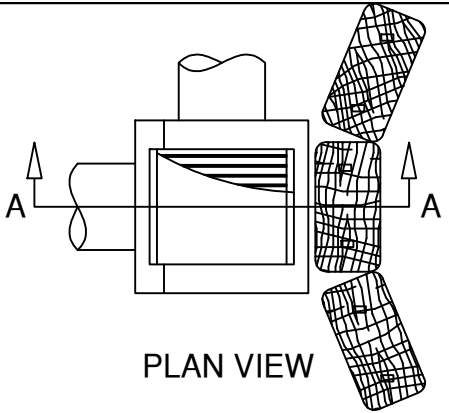

**DITCH INLET**

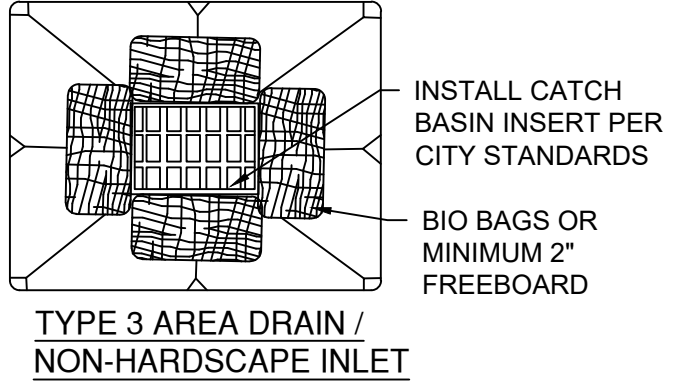
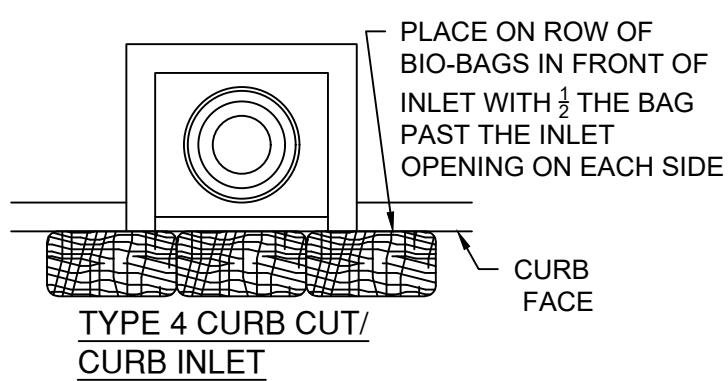
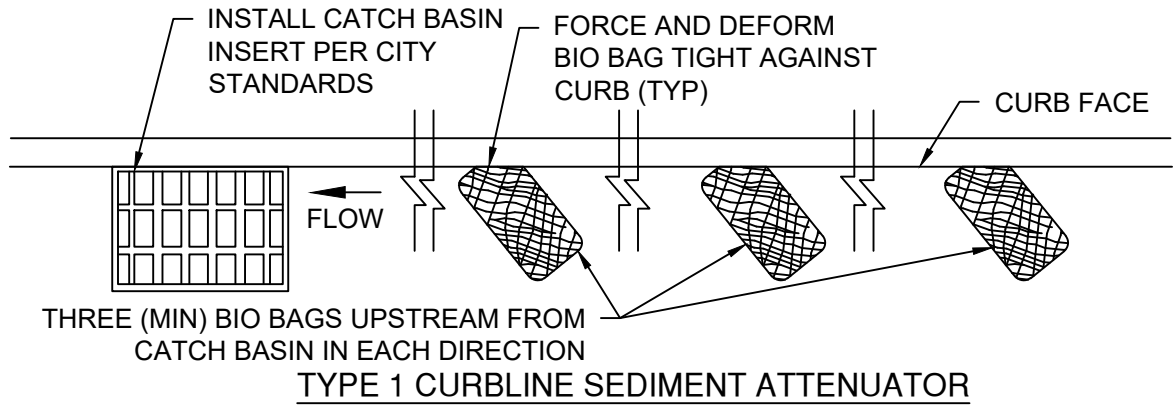

**NOTES:**

1. BIO-BAGS SHOULD BE STAKED WHERE APPLICABLE USING (2) 1"x2"x24" WOOD STAKES OR APPROVED EQUAL. LONGER STAKES WILL BE REQUIRED THERE IS HIGH RUNOFF OR LARGE SEDIMENT LOADS ANTICIPATED TO MAINTAIN BIO-BAGS IN POSITION.
2. TYPE 1 CURBLINE SEDIMENT ATTENUATOR SHALL BE INSTALLED AS REQUIRED.
3. BIO BAGS MAY BE REPLACED WITH A 2" MINIMUM FREEBOARD BETWEEN DISTURBED GROUND AND INLET GRATE.
4. SEDIMENT BARRIERS SHALL BE MAINTAINED UNTIL UPHILL AREA IS PERMANENTLY STABILIZED.
5. BIO-BAGS ARE NEVER TO BE PLACED IN COLLECTOR OR ARTERIAL STREETS UNLESS OTHERWISE APPROVED BY THE CITY.
6. INSPECTION & MAINTENANCE:
  - 6.1. INSPECT WEEKLY AND DAILY DURING STORM EVENTS.
  - 6.2. CLEAN, OR REPLACE, BIO-BAGS WHEN DEBRIS HAS REACH A HEIGHT OF 2 INCHES.
  - 6.3. CONTRACTOR IS RESPONSIBLE FOR REMOVING BIO-BAGS AND PROPERLY DISPOSING OF ALL MATERIALS ONCE THE PROJECT HAS BEEN PERMANENTLY STABILIZED.

DRAWN CJH	
DIV EROSION	
REV	DATE



**CITY OF BEND**  
STANDARD DRAWING  
710 NW WALL ST., BEND, OREGON 97701

**BIO BAG INLET PROTECTION**

SCALE NTS
DATE 11/01/2024
APPR
STD DWG E-2C

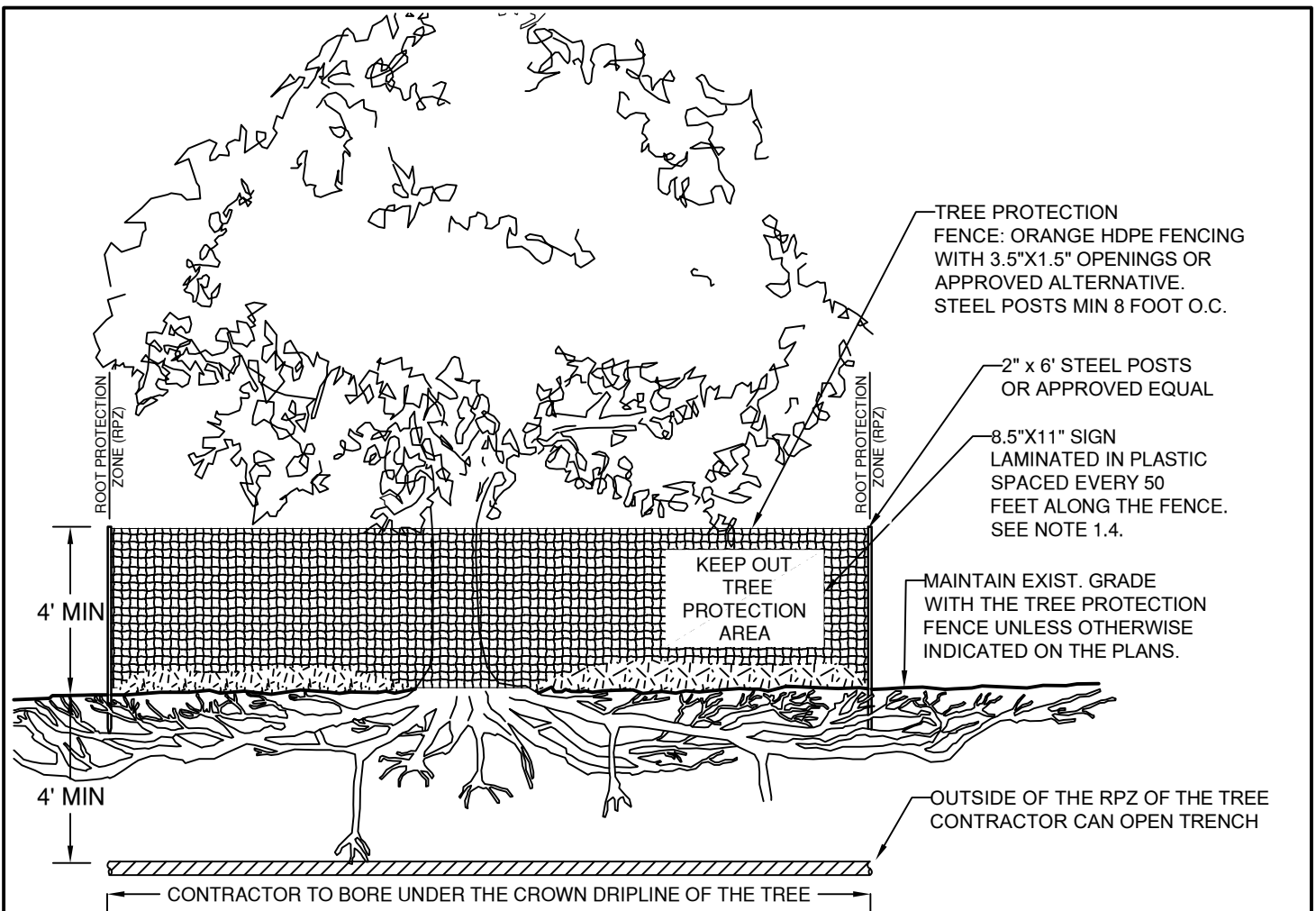

1. PROTECTION FENCING MUST:
  - 1.1. BE INSTALLED PRIOR TO ANY GRADING AND/OR SITE IMPROVEMENTS. FENCING TO BE MAINTAINED UNTIL THE GRADING PERMIT / SITE PERMIT IS COMPLETE.
  - 1.2. TREE PROTECTION METHODS MUST BE CONSISTENT WITH INTERNATIONAL SOCIETY OF ARBORICULTURE (ISA) BEST MANAGEMENT PRACTICES.
  - 1.3. PROTECTION FENCING MUST BE INSTALLED AT THE EDGE OF THE ROOT PROJECTION ZONE AND PERMISSIBLE ENCROACHMENT AREA. EXISTING STRUCTURES AND/OR SECURE FENCING AT LEAST 3.5 FEET TALL CAN SERVE AS THE REQUIRED PROTECTION FENCING.
  - 1.4. SIGNAGE DESIGNATING THE PROTECTION ZONE AND PENALTIES FOR VIOLATIONS MUST BE SECURED ON EACH FENCE AS REQUIRED BY THE BDC.
  - 1.5. FENCING IS TO BE INSPECTED WEEKLY OR AFTER HIGH WINDS. REPAIR AS NEEDED TO ENSURE CONFORMANCE.
2. ANY LANDSCAPING OR IRRIGATION APPROVED WITHIN THE ROOT PROTECTION ZONE MAY BE INSTALLED BEFORE OR AFTER THE REMOVAL OF THE PROTECTION FENCING AND MUST NOT DISTURB EXISTING TREES, INCLUDING ROOTS, WITHIN THE ROOT PROTECTION ZONE.
3. NO EQUIPMENT SHALL OPERATE INSIDE THE PROTECTION FENCING. AREA WITHIN THE FENCING WILL NOT BE USED FOR STAGING OR STORAGE.

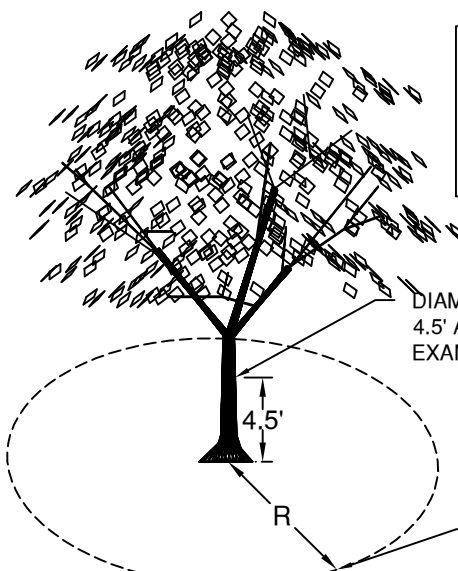

FENCE IS TO BE LOCATED AT THE ROOT PROTECTION ZONE. THIS MAY OR MAY NOT EXCEED THE TREE'S DRIP LINE, DEPENDENT ON THE TREE SIZE AT DBH.

MINOR ENCROACHMENT INTO THE RPZ WILL BE CONSIDERED WHERE IDENTIFIED IN AND APPROVED DURING PERMIT REVIEW.

ROOT PROTECTION ZONE (RPZ). MEASURE IS THE RADIUS "R" EQUAL TO THE "D" IN FEET. EXAMPLE, R=12'.

DRAWN CJH DIV EROSION REV DATE		<b>CITY OF BEND</b> STANDARD DRAWING 710 NW WALL ST., BEND, OREGON 97701	SCALE NTS
<b>CITY OF BEND</b>			DATE 11/01/2024
		<b>TREE/VEGETATION PROTECTION FENCING</b>	APPR
			STD DWG E-3

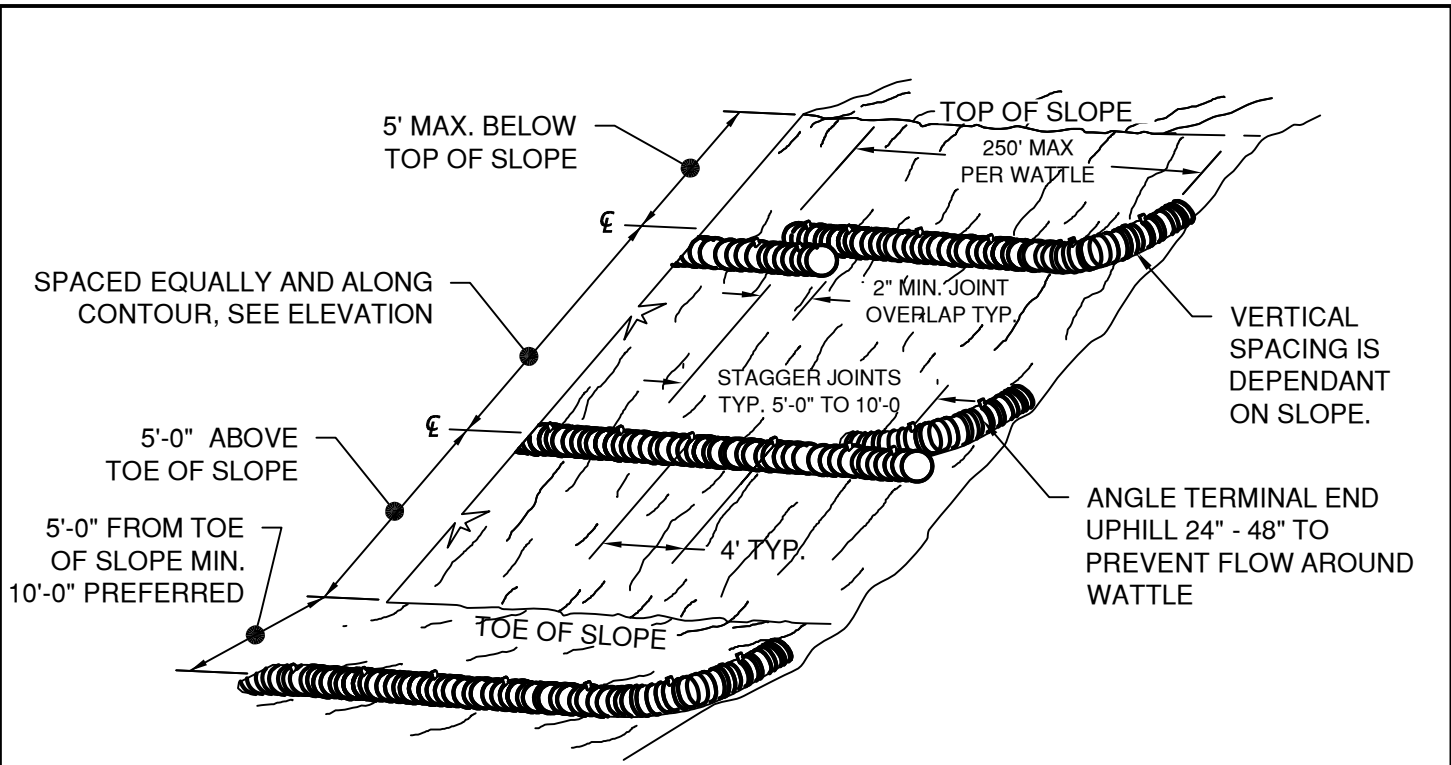

SLOPE APPLICATION - PERSPECTIVE VIEW

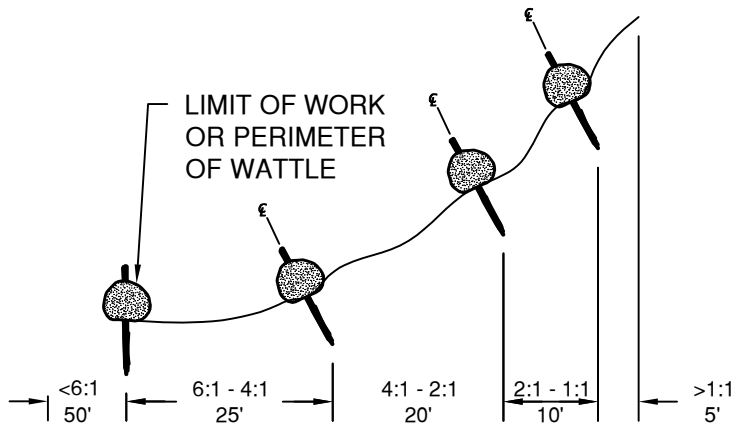
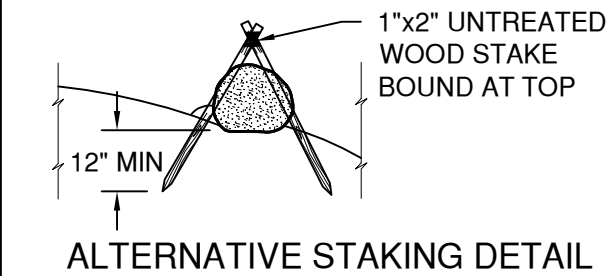
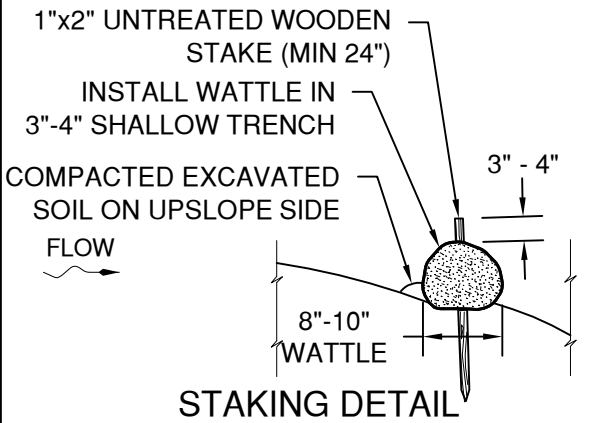

SLOPE APPLICATION - PLAN VIEW

- INSPECTION & MAINTENANCE**
1. INSPECT WEEKLY AND AFTER MAJOR STORM
  2. REMOVE ACCUMULATED SEDIMENT WHEN IT IS 1/3 CAPACITY OF WATTLE.
  3. REPAIR ADJACENT RILLS OR GULLIES PROMPTLY.

DRAWN CJH	
DIV EROSION	
REV	DATE



**CITY OF BEND**  
STANDARD DRAWING  
710 NW WALL ST., BEND, OREGON 97701

**WATTLES**

SCALE NTS
DATE 11/01/2024
APPR
STD DWG E-4

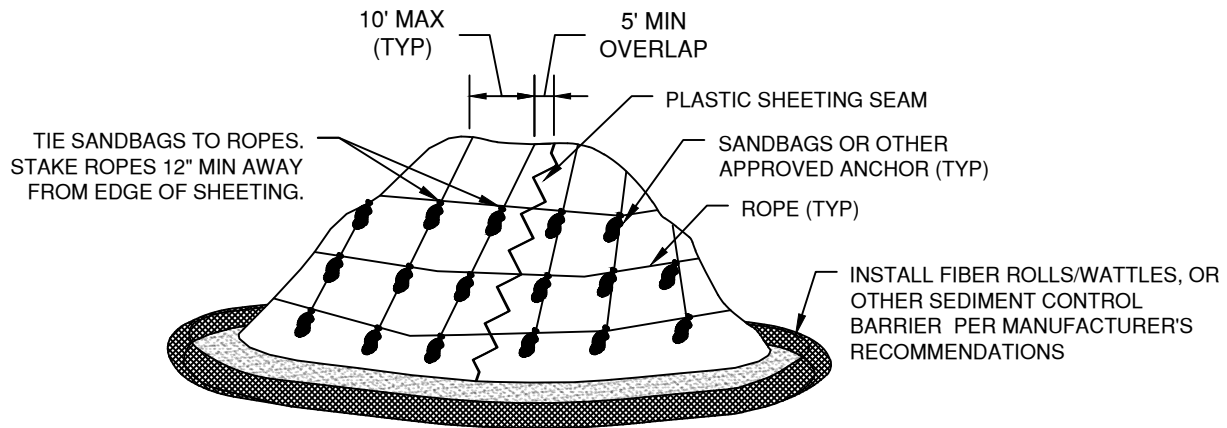

### TEMPORARY STOCKPILE STABILIZATION NTS

TRACK WALK THE FULL EXTENT OF THE SLOPE. (OPTIONAL OR AS DIRECTED BY THE CITY OR EOR FOR TREATING FOR SEDIMENT AND WIND RUNOFF)

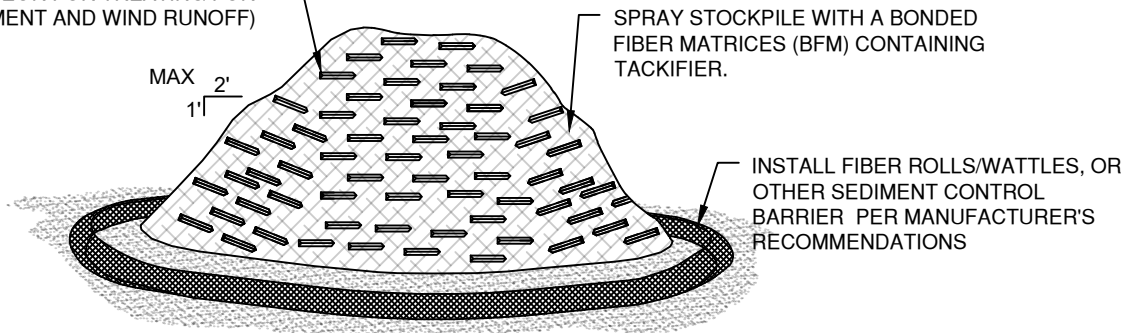

### PERMANENT STOCKPILE STABILIZATION NTS

**NOTES:**

**TEMPORARY STOCKPILE STABILIZATION:**

1. INSTALL PLASTIC SHEETING VERTICALLY DOWN SLOPE.
2. INSTALL PLASTIC SHEETING SO EDGES OVERLAP AND ARE SHINGLED AWAY FROM PREVAILING WINDS.
3. PLASTIC SHEETING SHOULD ONLY BE UTILIZED AS REQUIRED BY THE CITY WHERE OTHER METHODS OF STOCKPILE STABILIZATION HAVE NOT PERFORMED.

**INSPECTION AND MAINTENANCE:**

1. INSPECT WEEKLY AND DAILY DURING STORM EVENTS
2. REPLACE TORN SHEETS AND REPAIR OPEN SEAMS.
3. COMPLETELY REMOVE ALL PLASTIC AND REPLACE WHEN IT BEGINS TO DETERIORATE.
4. COMPLETELY REMOVE PLASTIC WHEN IT IS NO LONGER NEEDED.
5. CHECK ANCHORING SYSTEMS AND REPAIR OR ADD ANCHORS.
6. VERIFY EFFECTIVE FUNCTION OF BMP AT TOE OF SLOPE.

DRAWN CJH	
DIV EROSION	
REV	DATE



CITY OF BEND

CITY OF BEND

STANDARD DRAWING

710 NW WALL ST., BEND, OREGON 97701

STOCKPILE STABILIZATION

SCALE NTS

DATE 11/01/2024

APPR

STD DWG E-5

SLOPE APPLICATION LIMITED TO MANUFACTURER'S RECOMMENDATIONS. APPROVAL TO BE OBTAINED FOR SLOPES OVER 2:1 FOR STABILITY.

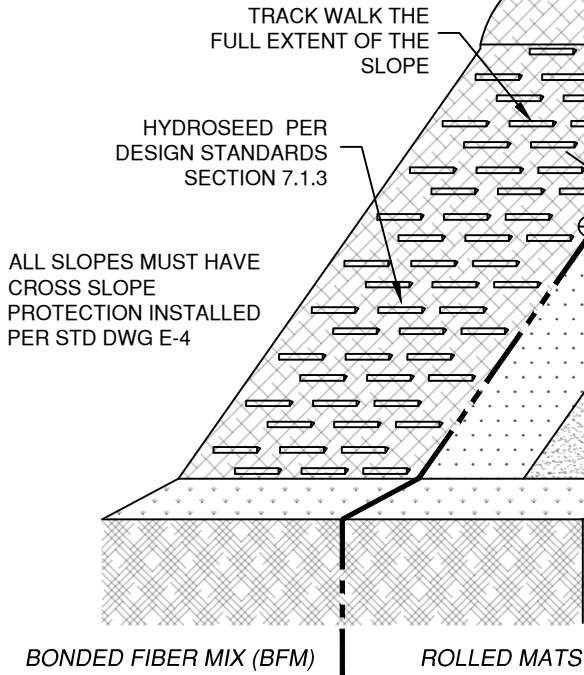

**ISOMETRIC VIEW**  
NTS

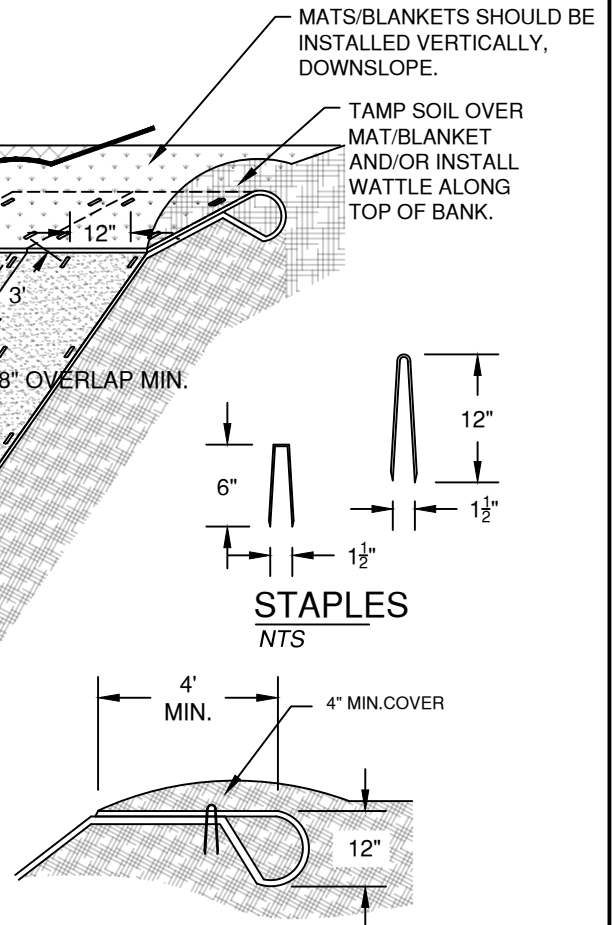

**STAPLES**  
NTS

**TOP BERM**  
NTS

**NOTES:**

1. PRIOR TO A SITE'S FINAL APPROVAL, ALL DISTURBED STEEP SLOPES MUST BE TREATED FOR LONG-TERM EROSION CONTROL. DISTURBED SOIL OF LESSER SLOPE SHALL BE STABILIZED AND TREATED IF SOIL HAS THE POTENTIAL TO LEAVE THE SITE OR ENTER A STORM DRAIN SYSTEM.
2. SLOPE SURFACE SHALL BE FREE OF ROCKS, CLODS OR LARGE ORGANIC DEBRIS. MATS/BLANKETS SHALL BE HAVE GOOD SOIL CONTACT.
3. APPLY PERMANENT SEEDING BEFORE PLACING MATS/BLANKETS.
4. LAY BLANKETS LOOSELY AND STAKE/STAPLE TO MAINTAIN DIRECT CONTACT WITH SOIL. DO NOT STRETCH.
5. MINIMUM STAKING OR STAPLING LAYOUT PATTERN - SEE MANUFACTURERS SPECIFICATIONS. USE 6-INCH STAPLES ON COMPACTED SOILS AND 12-INCH STAPLES ON LOOSE SOILS.

**INSPECTION AND MAINTENANCE:**

1. INSPECT WEEKLY AND DAILY DURING STORM EVENTS.
2. REPAIR ANY DAMAGED AREA OF THE MAT, BLANKET OR BFM. MAINTAIN OR PROVIDE ADDITIONAL ANCHORS AS NECESSARY TO MAINTAIN GROUND CONTACT.
3. IF EROSION OCCURS, REPAIR AND PROTECT THE ERODED AREA. ADDITIONAL CROSS SLOPE PROTECTION MAY BE REQUIRED.

DRAWN CJH	
DIV EROSION	
REV	DATE



**CITY OF BEND**

**CITY OF BEND**

STANDARD DRAWING

710 NW WALL ST., BEND, OREGON 97701

**SLOPE STABILIZATION**

SCALE NTS

DATE 11/01/2024

APPR

STD DWG E-5B

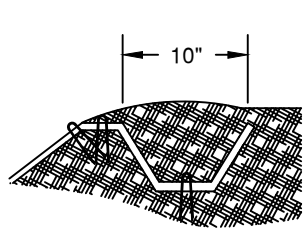

LONGITUDINAL ANCHOR TRENCH  
NTS

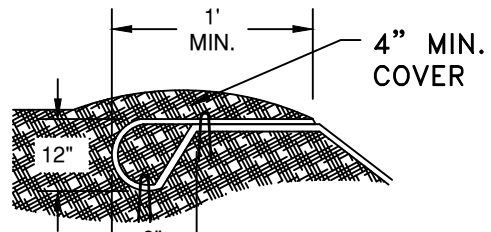

TERMINAL SLOPE AND CHANNEL ANCHOR TRENCH  
NTS

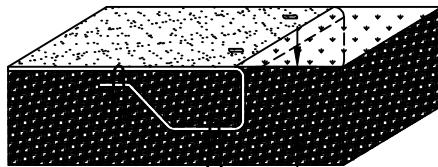
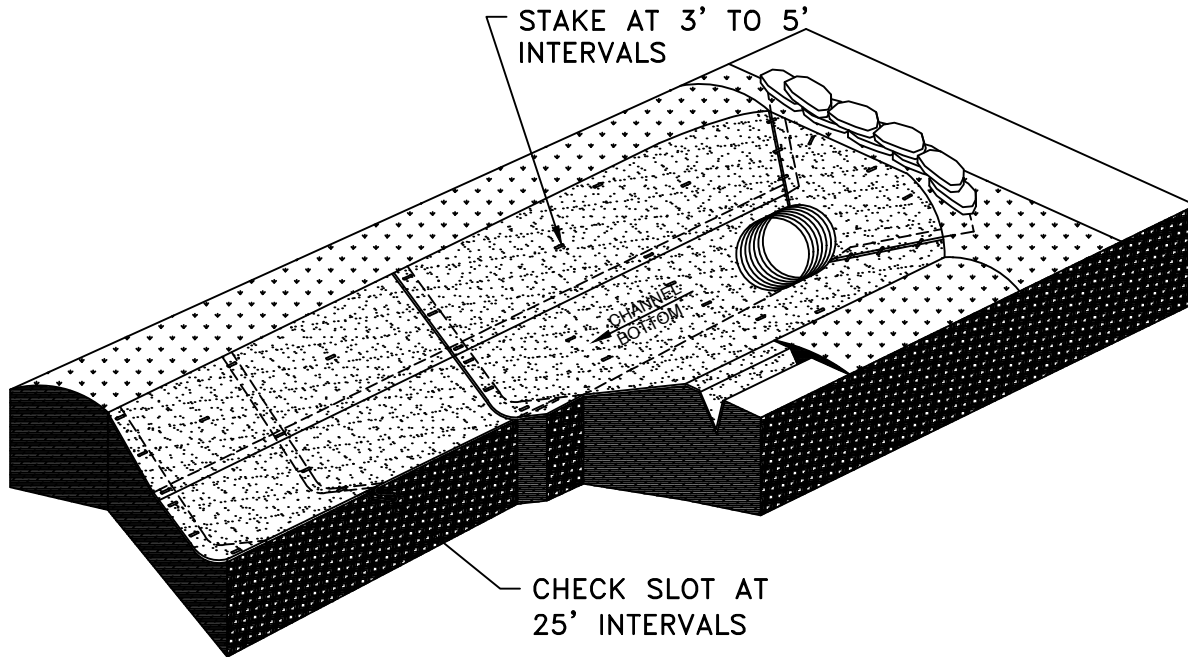

INITIAL ANCHOR TRENCH  
NTS

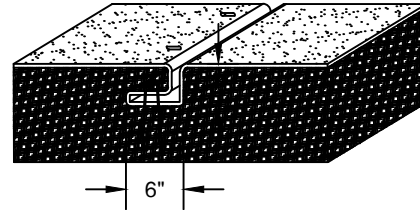

INTERMITTENT CHECK SLOT  
NTS

**NOTES:**

1. CHECK SLOTS TO BE CONSTRUCTED PER MANUFACTURERS RECOMMENDATIONS.
2. STAKING OR STAPLING LAYOUT PER MANUFACTURERS RECOMMENDATIONS.
3. SLOPE SURFACE SHALL BE FREE OF ROCKS, CLODS, STICKS, AND GRASS. MATS/BLANKETS SHALL HAVE GOOD SOIL CONTACT.
4. APPLY PERMANENT SEEDING BEFORE PLACING BLANKETS.
5. LAY BLANKETS LOOSELY AND STAKE OR STAPLE TO MAINTAIN DIRECT CONTACT WITH SOIL. DO NOT STRETCH.

CHANNEL STABILIZATION  
NTS

DRAWN LJC	
DIV EROSION	
REV	DATE
	12/1/17



CITY OF BEND

**CITY OF BEND**  
STANDARD DRAWING

710 NW WALL ST., BEND, OREGON 97701

**EROSION BLANKET - CHANNEL INSTALLATION**

SCALE NTS

DATE 10/01/21

APPR

STD DWG E-6

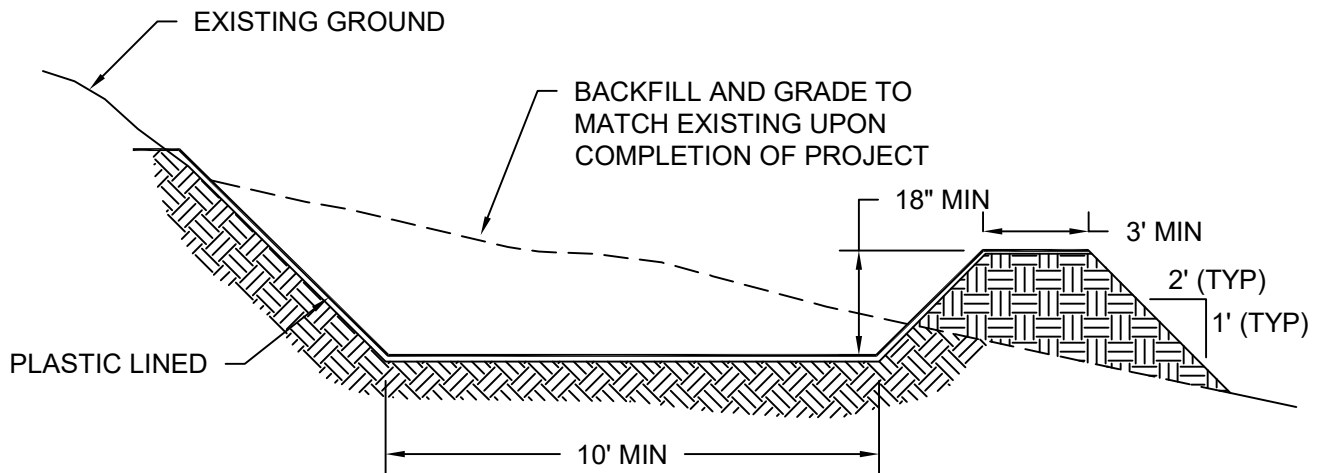
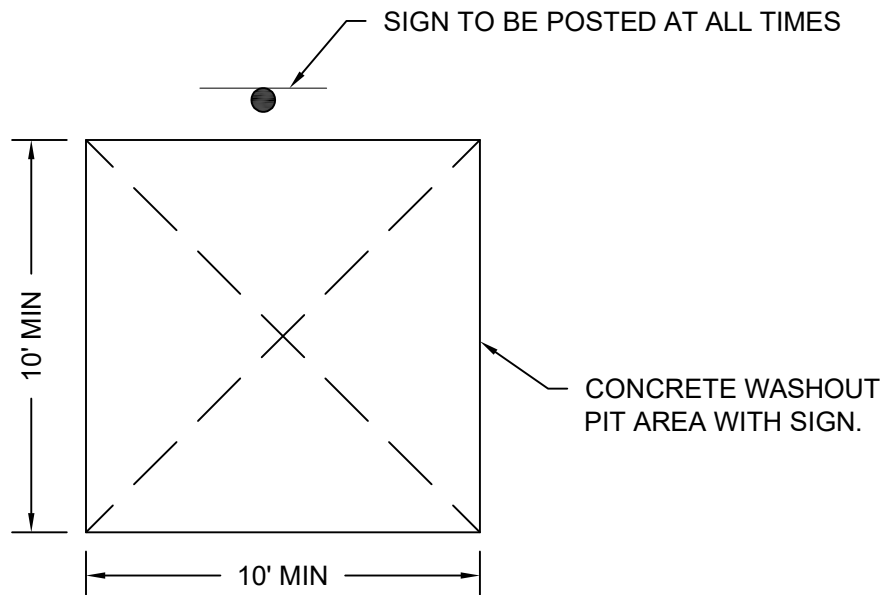

**NOTES:**

1. LOCATE THE WASHOUT A MINIMUM OF 50 FEET FROM ANY STORMWATER INLET AND/OR WATERBODY.
2. PREFABRICATED WASHOUT DEVICES MAY BE UTILIZED.

**INSPECTION & MAINTENANCE:**

3. INSPECT WEEKLY AND DAILY DURING STORM EVENTS.
4. WASHOUT FACILITIES MUST BE SERVICED OR REPLACED AND READY FOR USE ONCE THE FACILITY IS 75% FULL.
5. CONCRETE WASHOUT AREA TO BE REPAIRED AND/OR ENLARGED AS NECESSARY TO MAINTAIN CAPACITY FOR CONCRETE.
6. WASHOUT AREA TO BE REPAIRED AND/OR ENLARGED AS NECESSARY TO MAINTAIN CAPACITY FOR CONCRETE, WASHOUT AND SOLIDS.
7. UPON COMPLETION OF CONSTRUCTION ACTIVITIES, THE WASHOUT SHALL BE REMOVED AND THE AREA RESTORED TO FINISHED GRADE AND PRE-EXISTING CONDITIONS. CONTRACTOR TO LEGALLY DISPOSE OF WASTE MATERIALS.
8. CONTRACTOR SHALL TAKE PRECAUTIONS SO AS TO NOT OVERFLOW THE PIT.

DRAWN CJH	
DIV EROSION	
REV	DATE



CITY OF BEND

**CITY OF BEND**

STANDARD DRAWING

710 NW WALL ST., BEND, OREGON 97701

**CONCRETE TRUCK WASHOUT**

SCALE NTS

DATE 11/01/2024

APPR

STD DWG E-7

EDGE OF PAVEMENT.  
WHERE CURB EXISTS,  
APPLY CURB RAMP OR  
REMOVE CURB.

EXISTING ROADWAY

R=20'-25'

SEE NOTE 5  
LENGTH (L)

DIVERSION RIDGE REQUIRED  
WHERE GRADE EXCEED 2%

12' MIN.  
20' MAX.

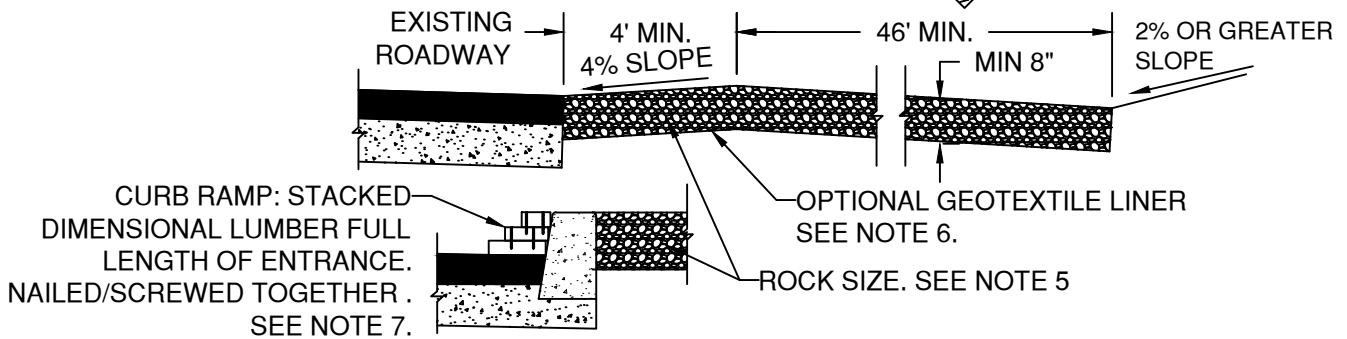

**NOTES:**

1. CONSTRUCTION ENTRANCE TO BE INSTALLED PRIOR TO ANY OTHER WORK ON SITE AND IS APPLICABLE AT ALL POINTS OF INGRESS AND EGRESS UNTIL SITE IS STABILIZED.
2. TIRE WASH FACILITY MAY BE REQUIRED ON SITE TO PREVENT TRACKING ONTO EXISTING ROADWAY. IF REQUIRED, CONSTRUCT TIRE WASH FACILITY PER ODOT STD DWG RD1060.
3. THE CONSTRUCTION AND USE OF THIS ENTRANCE IN NO WAY NEGATES THE CONTRACTOR'S RESPONSIBILITIES TO PREVENT TRACKING OF MATERIAL ONTO EXISTING ROADWAY.
4. ALTERNATIVE PROPRIETARY ENTRANCE MAY BE USED AS APPROVED BY THE CITY.
5. ROCK WILL BE CLEAN AND OPEN GRADED.
  - 5.1. FOR DEVELOPMENT (1-4 RESIDENTIAL UNITS), 3/4-INCH ROCK, L= 20 FEET. "SMALL INDIVIDUAL LOT"
  - 5.2. FOR ALL OTHER DEVELOPMENTS, 3 INCH TO 6 INCH ROCK, L= 50 FEET.
  - 5.3. 1 INCH TO 3 INCH ROCK CAN BE USED AS APPROVED BY THE CITY, L=100 FEET.
6. GEOTEXTILE LINER WILL BE REQUIRED UNDER ROCK WHERE SOILS ARE CLAY OR SHOW SIGNS OF PUMPING THROUGH ROCK.
7. STACKING OF MATERIAL AT CURB FACE FOR CONSTRUCTION ENTRANCE NOT PERMITTED IN BIKE LANES. WHERE BIKE LANES EXIST, CURB CUT MUST BE PERFORMED. DAMAGED CURB WILL BE REMOVED AND REPLACED.
8. INSPECTION & MAINTENANCE:
  - 8.1. INSPECT WEEKLY AND AFTER STORM EVENTS
  - 8.2. MUST BE MAINTAINED IN A CONDITION THAT WILL PREVENT TRACKING/SEDIMENT TRANSFER. INCLUDING BUT NOT LIMITED TO TOPPING, REMOVAL AND REPLACEMENT OF CONTAMINATED ROCK WITH CLEAN ROCK.
  - 8.3. ANY MATERIAL THAT STILL MAKES IT ONTO THE ROAD MUST BE SWEEP IMMEDIATELY AND PROPERLY DISPOSED OF. WASHING OF STREET IS NOT PERMITTED.

DRAWN CJH	
DIV EROSION	
REV	DATE



**CITY OF BEND**

**CITY OF BEND**

STANDARD DRAWING

710 NW WALL ST., BEND, OREGON 97701

**CONSTRUCTION ENTRANCE**

SCALE NTS

DATE 11/01/2024

APPR

STD DWG E-8

**TEMPORARY STABILIZATION**  
(EARTHWORK NOT AT FINISHED GRADE)

SEE BEND STANDARDS AND SPECIFICATIONS II, CHAPTER 7.1.3



TEMPORARY STABILIZATION IS REQUIRED WITHIN 10 DAYS OF INACTIVITY OR AS APPROVED BY CITY



ROUTINE PROJECT COMPLIANCE

**TEMPORARY STABILIZATION OPTION PROFILES**

TEMPORARY STABILIZATION **OPTION A**

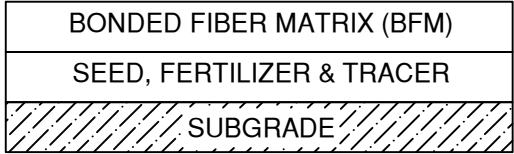

TEMPORARY STABILIZATION **OPTION B**

ALTERNATIVE AS APPROVED BY THE CITY IN WRITING

**PERMANENT STABILIZATION**  
(EARTHWORK AT FINISHED GRADE OR PROJECT IS DESIGNATED INACTIVE)

SEE BEND STANDARDS AND SPECIFICATIONS II, CHAPTER 7.1.3



PERMANENT STABILIZATION IS REQUIRED WITHIN 10 DAYS OF PROJECT COMPLETION OR IF NO WORK OCCURS AT THE PROJECT SITE OVER A 30 DAY PERIOD



FINAL PROJECT APPROVAL

**PERMANENT STABILIZATION OPTION PROFILES**

PERMANENT STABILIZATION **OPTION A**

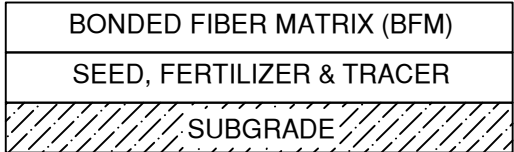

GERMINATION MUST ACHIEVE UNIFORM AERIAL PLANT COVERAGE OF >70%

PERMANENT STABILIZATION **OPTION B**

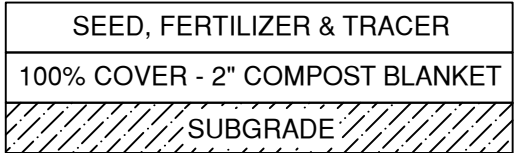

NO GERMINATION OR AERIAL COVERAGE REQUIRED.

PERMANENT STABILIZATION **OPTION C**

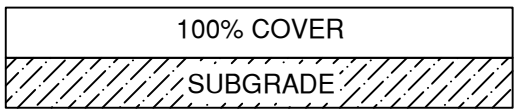

ALLOWED IN AREAS <5% SLOPE ONLY. COVER INCLUDES A 2 IN. THICK ROCK OR ORGANIC MULCH BLANKET.

PERMANENT STABILIZATION **OPTION D**

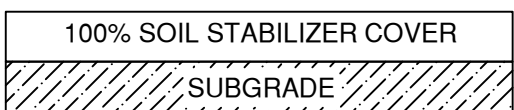

ALLOWED IN AREAS OF RESIDENTIAL DEVELOPMENT WITH <5% SLOPE, WHERE FINAL LOT GRADE IS ACHIEVED BUT VERTICAL CONSTRUCTION IS TO OCCUR AS A SEPARATE PHASE. APPLIED AT MANUFACTURE'S RECOMMENDED RATE WITH AN EFFECTIVE PERIOD OF NO LESS THAN 6 MONTHS.

PERMANENT STABILIZATION **OPTION E**

ALTERNATIVE AS APPROVED BY THE CITY IN WRITING

NOTES:

- A. WHEN A PROJECT IS DEEMED IN ACTIVE, WITH NO WORK OCCURRING OVER A 30 DAY PERMIT. THE PROJECT WILL BE REQUIRED TO BE PERMANENTLY STABILIZED.
- B. FOR PROJECTS WHERE SLOPES EXCEED 5%, SEE SLOPE / STOCKPILE STABILIZATION STANDARDS FOR ADDITIONAL DETAILS AND REQUIREMENTS.
- C. WHEN THE POTENTIAL EXISTS FOR SEDIMENT TO IMPACT ADJACENT PROPERTY OR PUBLIC AND PRIVATE STORM DRAINAGE SYSTEMS ADDITIONAL BMPs MAY BE REQUIRED BY THE CITY TO ENSURE PROTECTION AND FULL STABILIZATION PRIOR TO FINAL APPROVAL.

DRAWN	CJH
DIV	EROSION
REV	DATE



CITY OF BEND

**CITY OF BEND**

STANDARD DRAWING

710 NW WALL ST., BEND, OREGON 97701

**STABILIZATION REQUIREMENTS**

SCALE NTS

DATE 11/01/2024

APPR

STD DWG E-9

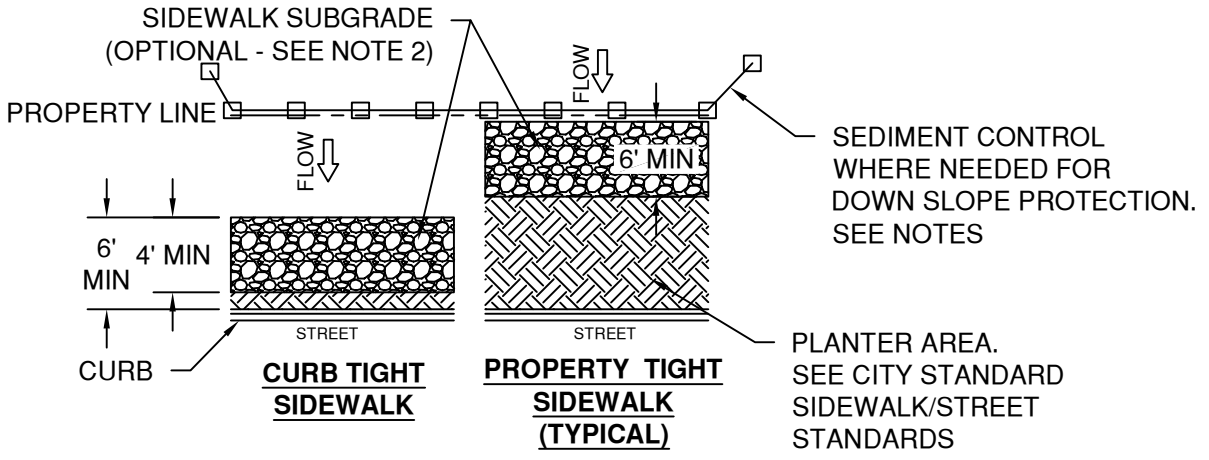

**CURB TIGHT SIDEWALK PROFILE**

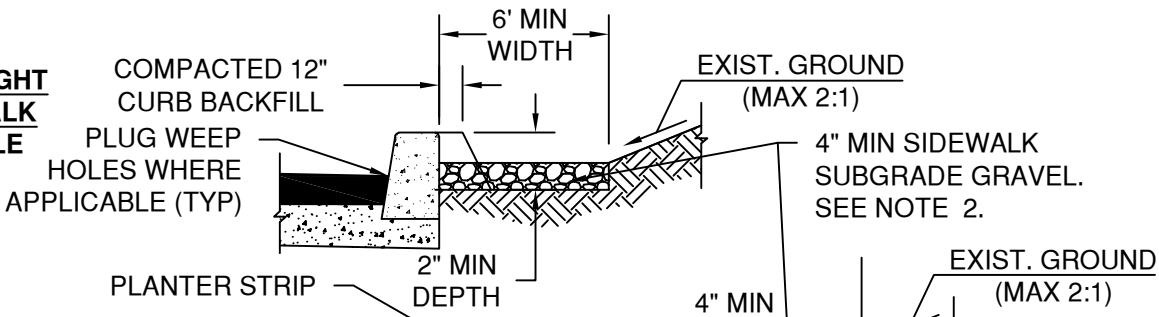

**PROPERTY TIGHT SIDEWALK PROFILE**

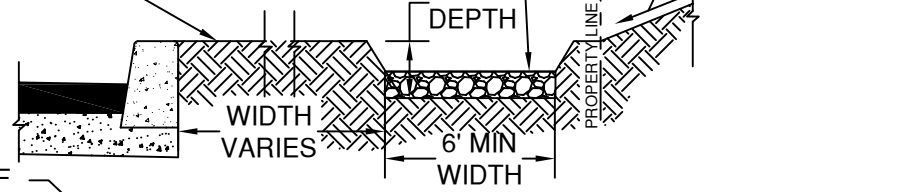

**EDGE OF PAVEMENT**

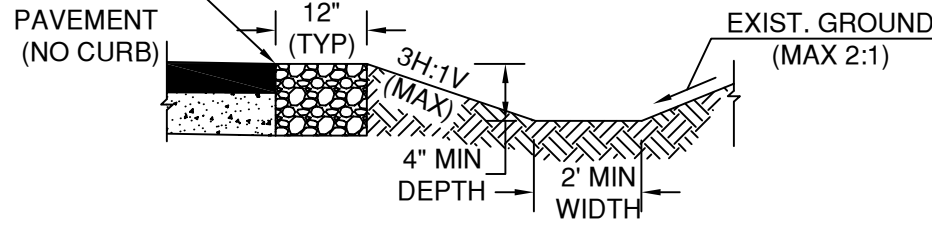

**NOTES:**

1. WHERE SIDEWALKS ARE INSTALLED, OR THE PROPERTY SLOPES AWAY FROM THE ROAD, THIS STANDARD IS NOT APPLICABLE. DISTURBED SOILS ARE TO BE STABILIZED TO CITY STANDARDS. WHERE SEDIMENT CONTROL IS INSTALLED, IT MUST BE PLACED AT THE PROPERTY LINE OUTSIDE THE RIGHT OF WAY, ALLOWING ACCESS TO THE RIGHT OF WAY. STORMWATER FLOWS INTO THE RIGHT OF WAY WILL BE REMEDIATED, PER COSM AND TITLE 16, WITH LOT DEVELOPMENT.
2. THE GRAVEL SIDEWALK SUBGRADE / BASE IS OPTIONAL. WHERE APPLIED, GRAVEL TO BE REMOVED OR ADDITIONAL GRAVEL TO BE ADDED (TO ACHIEVE CITY STANDARDS) WITH SIDEWALK CONSTRUCTION DEPENDING ON LEVEL OF GRAVEL CONTAMINATION.
3. SITE SLOPES GRATER THAN 5% TOWARDS THE SIDEWALK/STREET SUBGRADE MAY BARRIER REQUIRE ADDITIONAL SEDIMENT CONTROL BMPs (SEDIMENT FENCE, STRAW WATTLE, ETC.)
4. SIDEWALK SUBGRADE GRAVEL TO MEET CITY STANDARDS.
5. INSPECTION & MAINTENANCE:
  - 5.1. INSPECT WEEKLY AND AFTER STORM EVENTS.
  - 5.2. REMOVE SEDIMENT WHEN ACCUMULATION IS GREATER THAN 50% OF THE CAPACITY.

DRAWN CJH	
DIV EROSION	
REV	DATE



**CITY OF BEND**  
STANDARD DRAWING  
710 NW WALL ST., BEND, OREGON 97701

**SUBGRADE BARRIER**

SCALE NTS
DATE 11/1/2024
APPR
STD DWG E-10

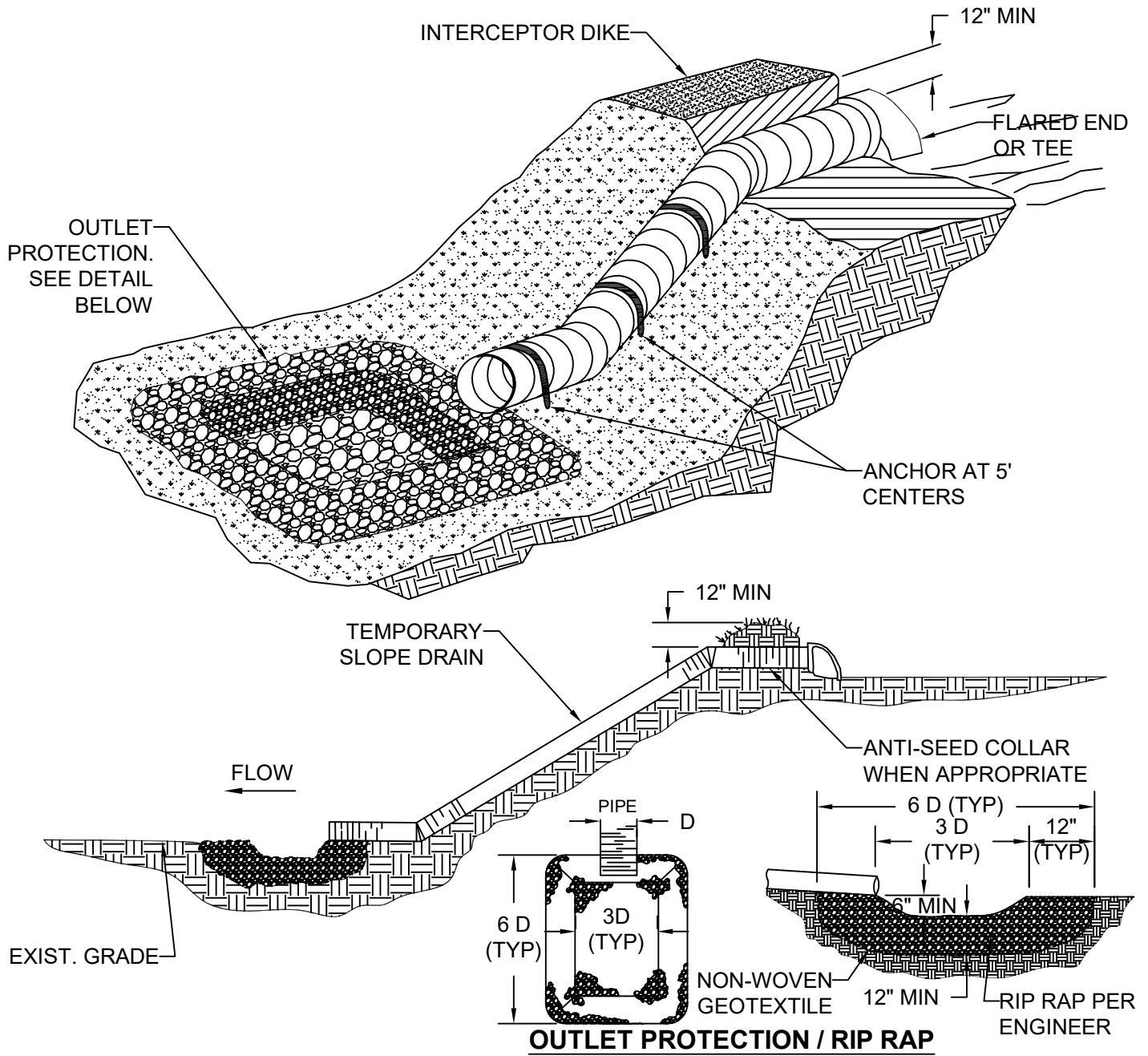

**OUTLET PROTECTION / RIP RAP**

**RIPRAP:**

- ROCK FOR RIPRAP SHALL BE ANGULAR IN SHAPE.
- THICKNESS OF A SINGLE RAMP SHALL NOT BE LESS THAN 1/3 ITS LENGTH.
- DESIGN BASED ON ODOT HYDRAULICS MANUAL AND COSM.

**RIPRAP INSTALLATION:**

- EXCAVATE BELOW FINISHED GRADE TO DEPTH & DIMENSION SHOWN ON APPROVED PLANS.
- INSTALL WOVEN GEOTEXTILE FABRIC.
- PLACE RIP RAP TO FINISHED GRADE.

GRADE RIPRAP SHALL BE THE CLASS AND SIZE OF ROCK ACCORDING TO THE FOLLOWING:					
CLASS 50	CLASS 100	CLASS 200	CLASS 700	CLASS 2000	
WEIGHT OF ROCK (LBS)					% (BY WEIGHT)
50-30	100-60	200-140	700-500	2000-1400	20
30-15	60-25	140-80	500-200	1400-700	30
15-2	25-2	80-8	200-20	700-40	40
2-0	2-0	8-0	20-0	40-0	10

DRAWN CJH	
DIV EROSION	
REV	DATE



**CITY OF BEND**  
 STANDARD DRAWING  
 710 NW WALL ST., BEND, OREGON 97701  
**PIPE SLOPE DRAIN**

SCALE NTS
DATE 11/01/2024
APPR
STD DWG E-11

**NOTES:**

1. DIRECT THE OUTLET SIDE OF THE ROCK/COMPOST FILTER BERMS ONTO A STABILIZED AREA, SUCH AS VEGETATION AND/OR ROCK.
2. EMBED ROCK FILTER BERM A MIN. OF 4" INTO THE EXISTING GROUND/EMBANKMENT.
3. USE ROCK FILTER BERM ON 2H:1V OR FLATTER SIDE SLOPES.
4. PLACE FILTER BERMS ALONG OR ON THE GROUND CONTOUR WITH THE ENDS TURNED UP SLOPE.
5. PRIOR TO INSTALLING A FILTER BERM IN A VEGETATED AREA, ENSURE THAT THE VEGETATION IS CUT TO A HEIGHT OF NO GREATER THAN 3" PRIOR TO INSTALLATION.
6. COMPOST HAS NOT BEEN CHEMICALLY TREATED AND IS WEED-FREE, PLASTIC-FREE, DECOMPOSED, NON-WOODY PLANT MATERIAL; ANIMAL WASTE IS NOT ALLOWED.
7. WHERE POSSIBLE, BERMS SHOULD BE PLACED AWAY FROM THE TOE OF THE SLOPE A MINIMUM OF 5 FEET TO ALLOW FOR ENERGY DISSIPATION AND STORAGE.

**INSPECT & MAINTENANCE:**

1. INSPECT WEEKLY AND DAILY DURING STORM EVENTS.
2. REMOVE SEDIMENT WHEN ACCUMULATION IS AT 1/3 THE CAPACITY.
3. REPAIR ANY BREAKS OR EROSION OCCURRING IN THE BERM.

FILTER BERM DIMENSIONS AND SPACING BASED ON SLOPE				
SLOPE	BERM SPACING	BERM DIMENSIONS		
		HEIGHT	BOTTOM WIDTH	TOP WIDTH
>50:1	250 Ft	1 Ft	2 Ft (MIN)	1 Ft
50:1 - 10:1	125 Ft	1 Ft	2 Ft (MIN)	1 Ft
10:1 - 5:1	100 Ft	1 Ft	2 Ft (MIN)	1 Ft
3:1 - 2:1	50 Ft	1.30 Ft	2.6 Ft (MIN)	1 Ft
>2:1		1.50 Ft	3 Ft (MIN)	1 Ft

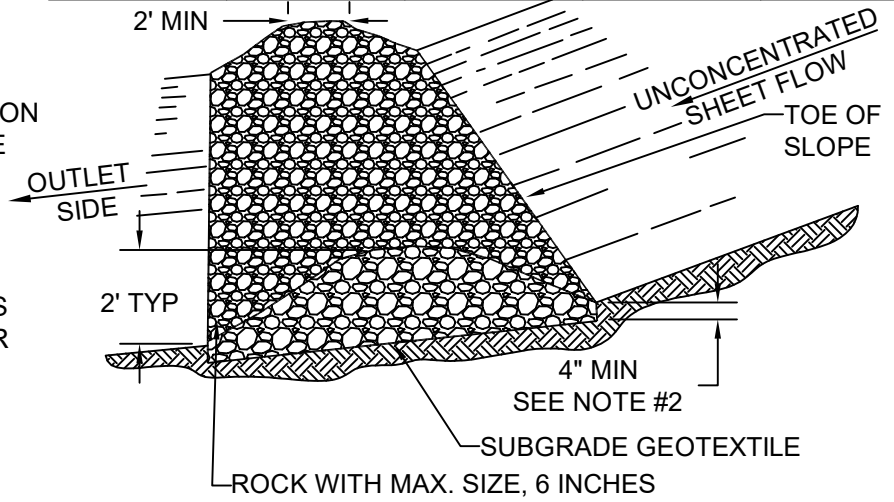

**ROCK FILTER BERM**

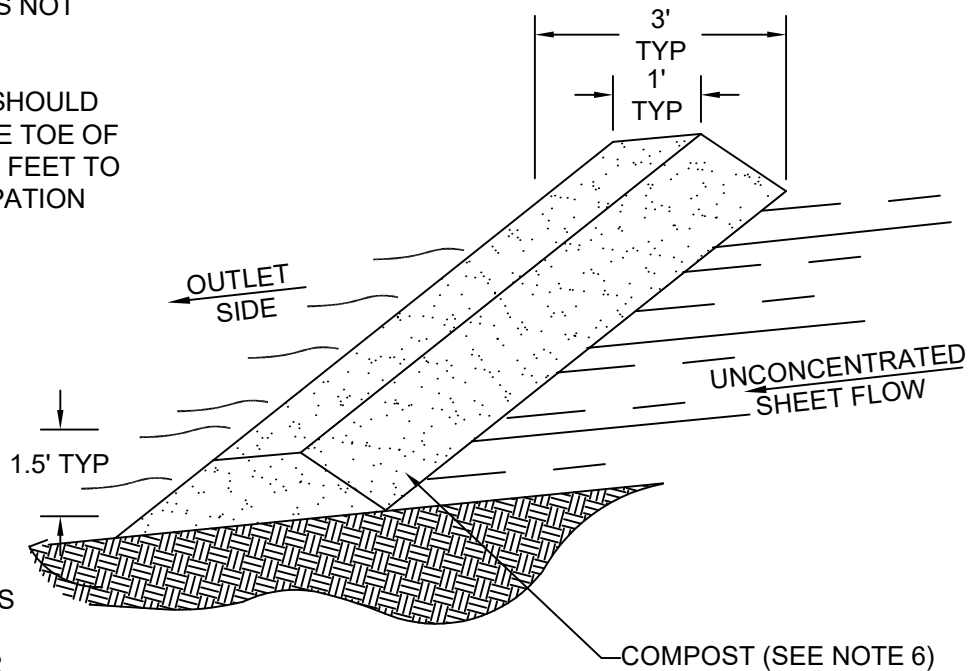

**COMPOST FILTER BERM**

DRAWN CJH	
DIV EROSION	
REV	DATE



CITY OF BEND

**CITY OF BEND**

STANDARD DRAWING

710 NW WALL ST., BEND, OREGON 97701

**FILTER BERMS**

SCALE NTS

DATE 11/01/2024

APPR

STD DWG E-12

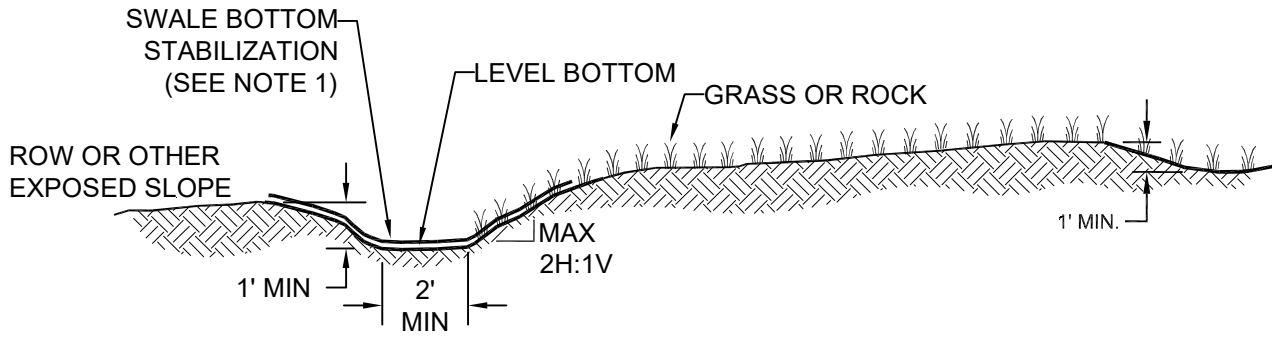

**DIVERSION SWALE**

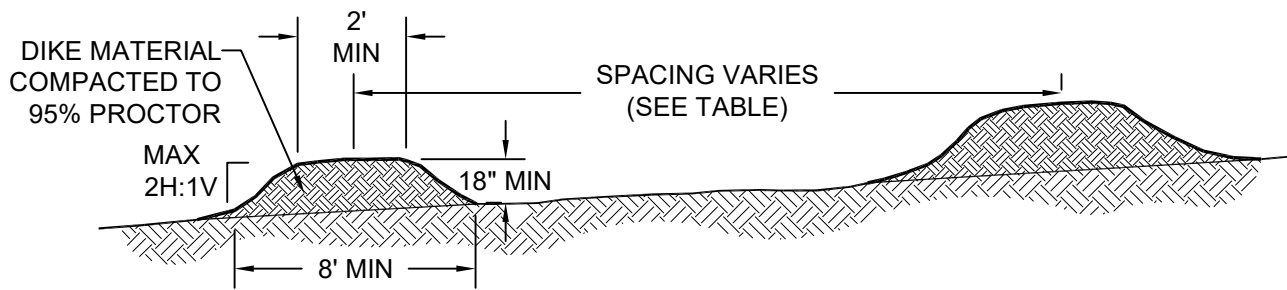

**TEMPORARY DIVERSION DIKE**

**NOTES:**

1. STABILIZE SWALE BOTTOMS WITH ESTABLISHED VEGETATION OR EROSION CONTROL BLANKETS PRIOR TO USE.
2. CONSTRUCT WITH POSITIVE DRAINAGE TO AN APPROVED OUTLET, SUCH AS SEDIMENTATION POND/TRAP.

**INSPECTION AND MAINTENANCE:**

3. INSPECT WEEKLY AND DAILY DURING STORM EVENTS.
4. IMMEDIATELY REPAIR DAMAGE OCCURRING AS A RESULT OF RUNOFF OR CONSTRUCTION ACTIVITY.
5. IF DIKE OR SWALE REGULARLY OVERFLOW, INCREASE CAPACITY OR FREQUENCY OF DIKES/SWALES.
6. DIRECT TRAFFIC TO MINIMIZE IMPACTS OVER DIKES / SWALES.

<b>DIVERSION SPACING</b>	
<b>SLOPE</b>	<b>SPACING</b>
< 5%	300 FEET
5 - 10 %	200 FEET
10 - 40 %	100 FEET

DRAWN CJH	
DIV EROSION	
REV	DATE



CITY OF BEND

**CITY OF BEND**

STANDARD DRAWING

710 NW WALL ST., BEND, OREGON 97701

**DIVERSION SWALES AND DIKES**

SCALE NTS

DATE 11/01/2024

APPR

STD DWG E-13

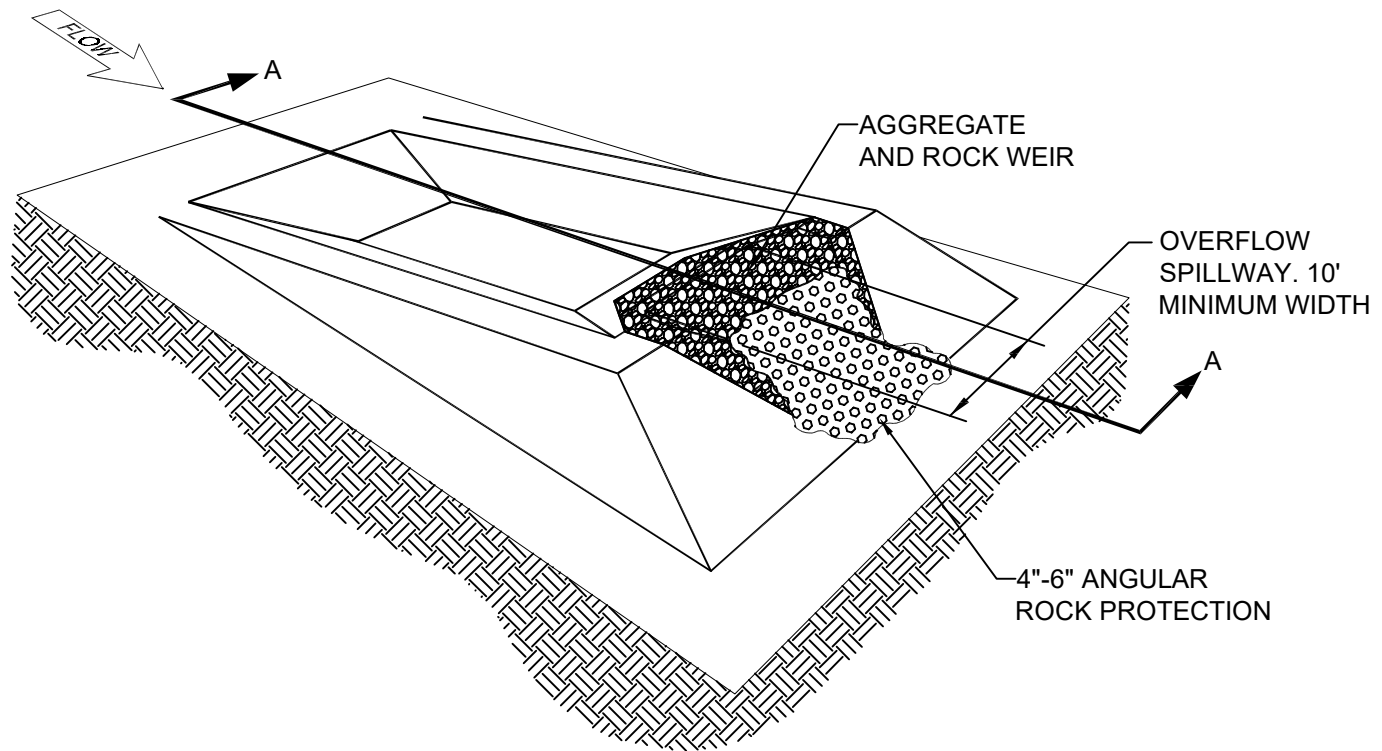

**SEDIMENT TRAP OUTLET**  
NTS

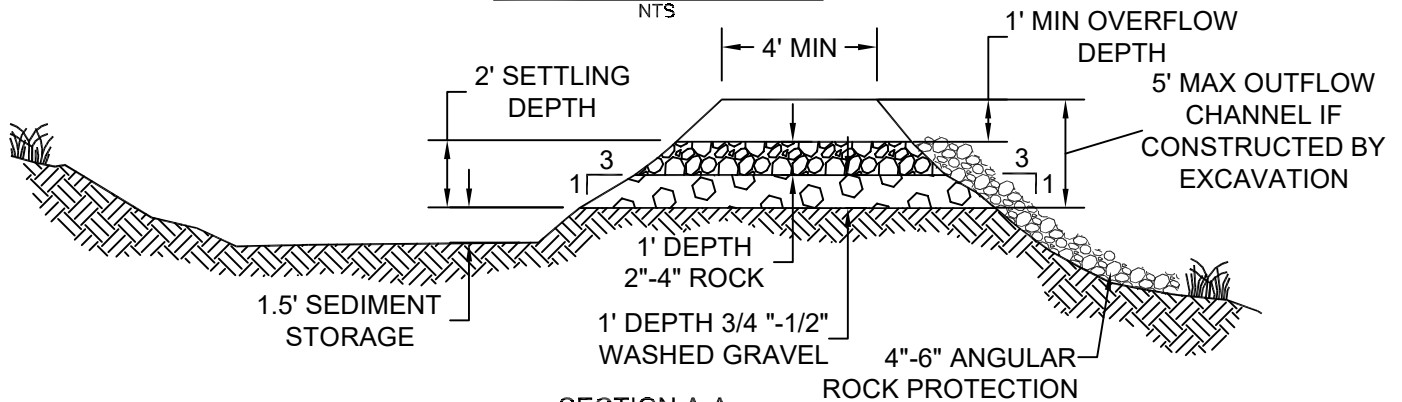

**SECTION A-A**  
NTS

**NOTES:**

1. MAY BE CONSTRUCTED BY EXCAVATION OR BY BUILDING A BERM.
2. NO SEDIMENT LADEN WATER IS ALLOWED TO DISCHARGE FROM THE PROJECT. A FILTER MUST BE CONSTRUCTED TO FILTER RUNOFF FROM THE SEDIMENT TRAP PRIOR TO DISCHARGE FROM THE CONSTRUCTION SITE.
3. UTILIZE A SEDIMENT TRAP AT THE LOW POINT(S) OF THE PROJECT WITHIN PERIMETER CONTROL BMPs.

**INSPECTION AND MAINTENANCE:**

4. INSPECT WEEKLY AND DAILY DURING STORM EVENTS.
5. SEDIMENT FROM THE TRAP WHEN ACCUMULATION IS AT 1/3 CAPACITY.
6. REPAIR ANY DAMAGE TO THE TRAP, EMBANKMENTS OR SLOPES.

DRAWN CJH	
DIV EROSION	
REV	DATE



CITY OF BEND

**CITY OF BEND**

STANDARD DRAWING

710 NW WALL ST., BEND, OREGON 97701

**SEDIMENT TRAP**

SCALE NTS

DATE 11/01/2024

APPR

STD DWG E-14

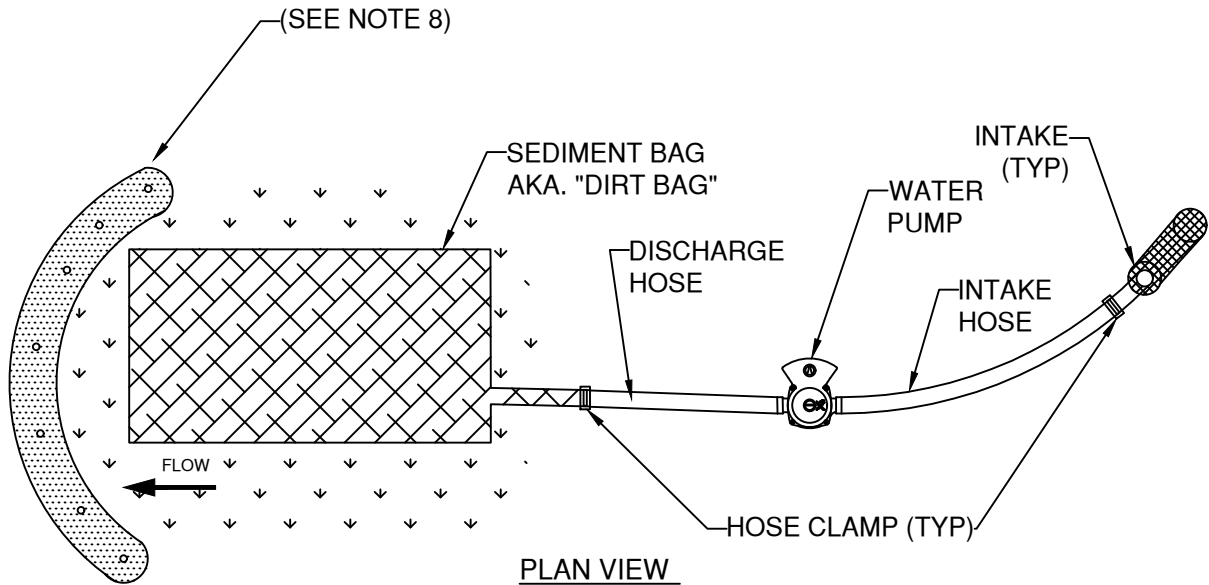

**NOTES:**

1. THE SEDIMENT BAG SHALL BE MANUFACTURED USING A POLYPROPYLENE 8 OZ. NON-WOVEN GEOTEXTILE SEWN INTO A BAG WITH A DOUBLE NEEDLE, USING A HIGH STRENGTH THREAD.
2. EACH STANDARD SEDIMENT BAG MUST HAVE A FILL SPOUT LARGE ENOUGH TO ACCOMMODATE A 4" DISCHARGE HOSE. STRAPS ARE ATTACHED TO SECURE THE HOSE AND PREVENT PUMPED WATER FROM ESCAPING WITHOUT BEING FILTERED.
3. THE SEDIMENT BAG SHALL MEET OR EXCEED OVERALL BAG REMOVAL EFFICIENCY RATE OF 97.55%.
4. WATER BEING DISCHARGED FROM THE SEDIMENT BAG MUST BE FREE OF ALL SEDIMENT PRIOR TO LEAVING THE SITE OR ENTERING INTO THE STORM SYSTEM.
5. SEDIMENT BAG IS FULL WHEN IT NO LONGER CAN EFFICIENTLY FILTER SEDIMENT OR ALLOW WATER TO PASS AT A RATE LESS THAN 50% OF MANUFACTURER'S DESIGNED FLOW RATE.
6. DURING USE, THE SEDIMENT BAG MUST BE MONITORED.
7. DISPOSE OF USED SEDIMENT BAG OFF SITE OR AS APPROVED BY CITY OF BEND.
8. WHEN APPROPRIATE, INSTALL DOWNSTREAM SEDIMENT CONTROL MEASURES PER CITY OF BEND.
9. STANDARDS.FOR BEST RESULTS, PLACE SEDIMENT BAG ON FLAT SURFACE.
10. SEDIMENT BAG SHOULD BE PLACED ON EXISTING VEGETATION, ROCK, OR BED OF STRAW. SEDIMENT BAG SHOULD NOT BE PLACED ON BARE GROUND.

DRAWN CJH	 <b>CITY OF BEND</b>	<b>CITY OF BEND</b> STANDARD DRAWING 710 NW WALL ST., BEND, OREGON 97701	SCALE NTS
DIV EROSION			DATE 11/01/2024
REV DATE			APPR
		<b>DEWATERING SEDIMENT BAG</b>	STD DWG E-15

---

**CITY OF BEND STANDARD DRAWINGS**  
**Landscaping (L)**

---

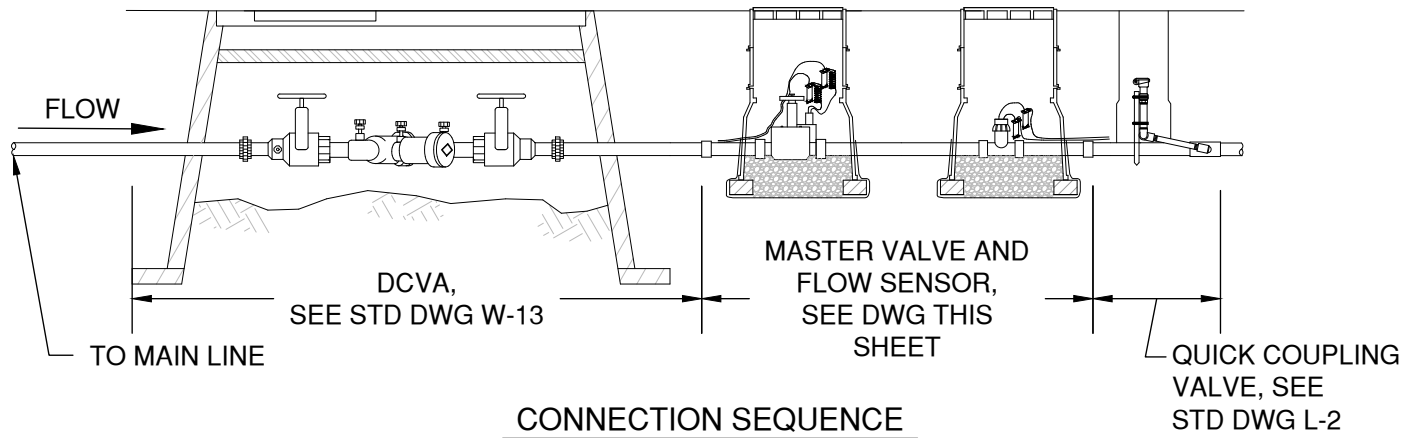

**CONNECTION SEQUENCE**

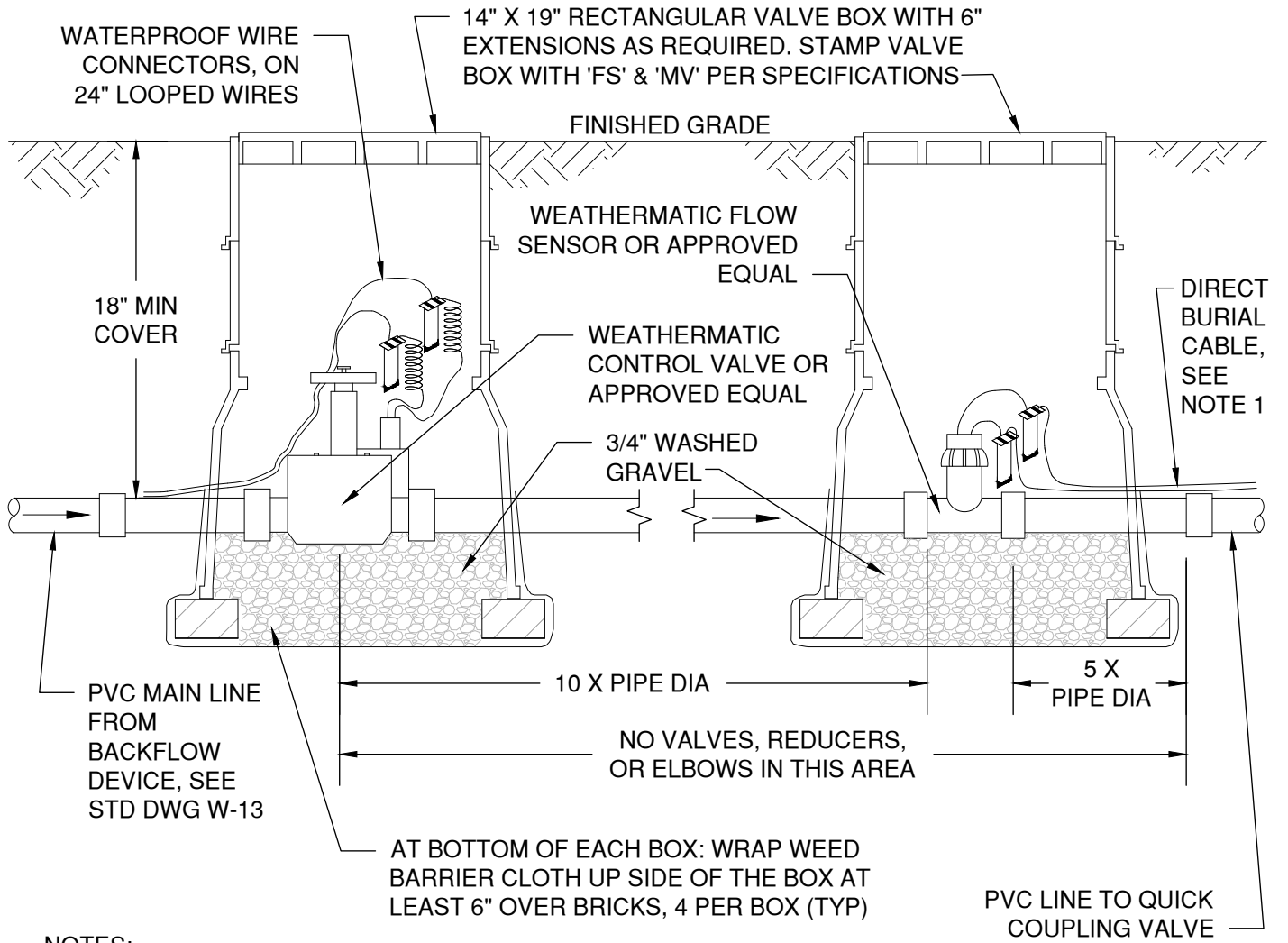

**NOTES:**

1. DIRECT BURIAL 1 PAIR, TWISTED SHIELDED CABLE-MIN CONDUCTOR SIZE 20 AWG. DO NOT EXCEED 2,000 FEET IN LAYING DISTANCE FROM FLOW SENSOR TO IRRIGATION CONTROLLER.
2. SIZE FLOW SENSOR BASED ON REQUIRED GPM NEEDED ON PROJECT.
3. MIN DISTANCES BETWEEN ANY FITTING OR VALVE AND FLOW SENSOR ARE NOTED ABOVE.

DRAWN ARS  
DIV LNDSCP  
REV DATE



**CITY OF BEND**

STANDARD DRAWING

710 NW WALL ST., BEND, OREGON 97701

**IRRIGATION CONNECTION SEQUENCE AND  
MASTER VALVE AND FLOW SENSOR**

SCALE NTS

DATE 04/16/2026

APPR

STD DWG L-1

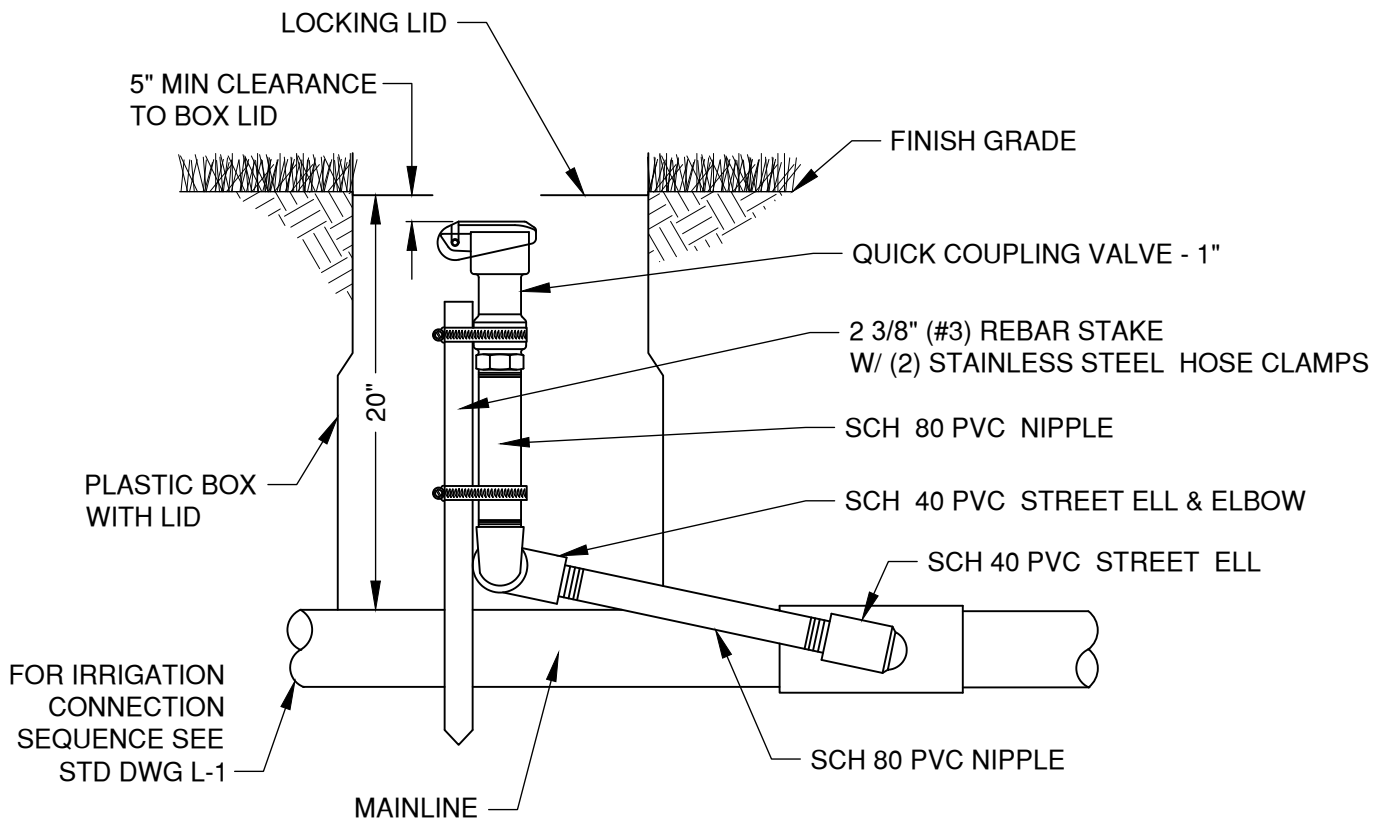

DRAWN LJC  
 DIV LNDSCLP  
 REV DATE



**CITY OF BEND**  
 STANDARD DRAWING  
 710 NW WALL ST., BEND, OREGON 97701

**IRRIGATION BLOWOUT - QUICK COUPLING VALVE**

SCALE NTS  
 DATE 04/16/2026  
 APPR  
 STD DWG L-2

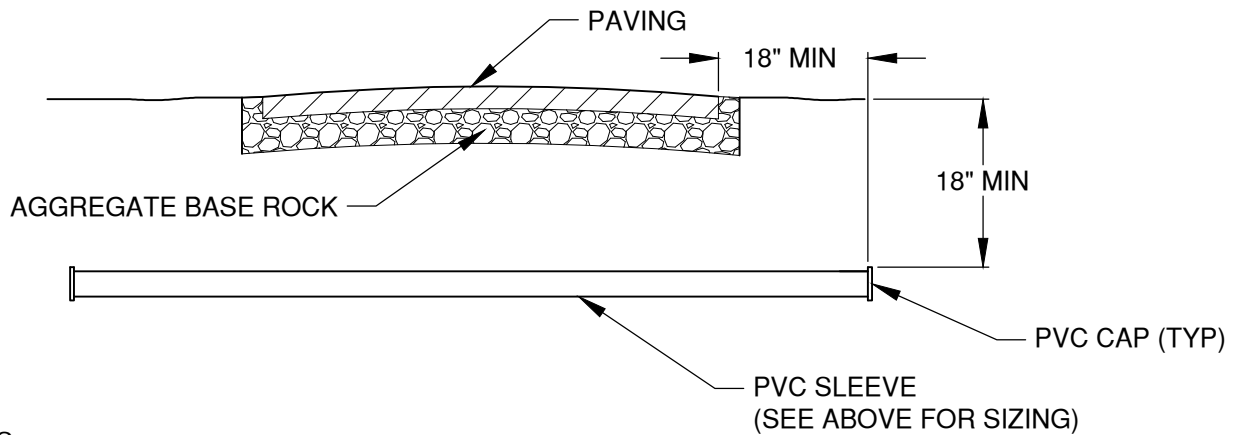
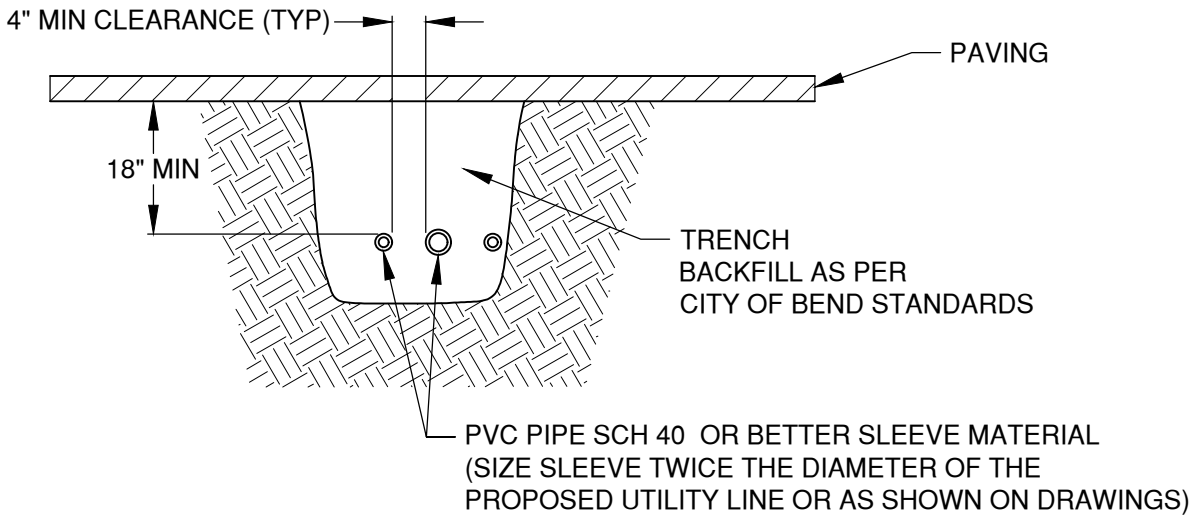

**NOTES:**

1. COMPACTION SHALL MEET 00405.46C PER CITY OF BEND SPECIAL PROVISIONS
2. 12" MIN COVER UNDER SIDEWALKS
3. SEE STD DWGS R-10 AND R-11 FOR TRENCH BACKFILL AND ROAD RESTORATION REQUIREMENTS.

DRAWN AJD	
DIV LNDSCP	
REV	DATE



**CITY OF BEND**  
STANDARD DRAWING  
710 NW WALL ST., BEND, OREGON 97701

---

**IRRIGATION SLEEVE UNDER PAVING**

SCALE NTS
DATE 01/31/2022
APPR
STD DWG L-3

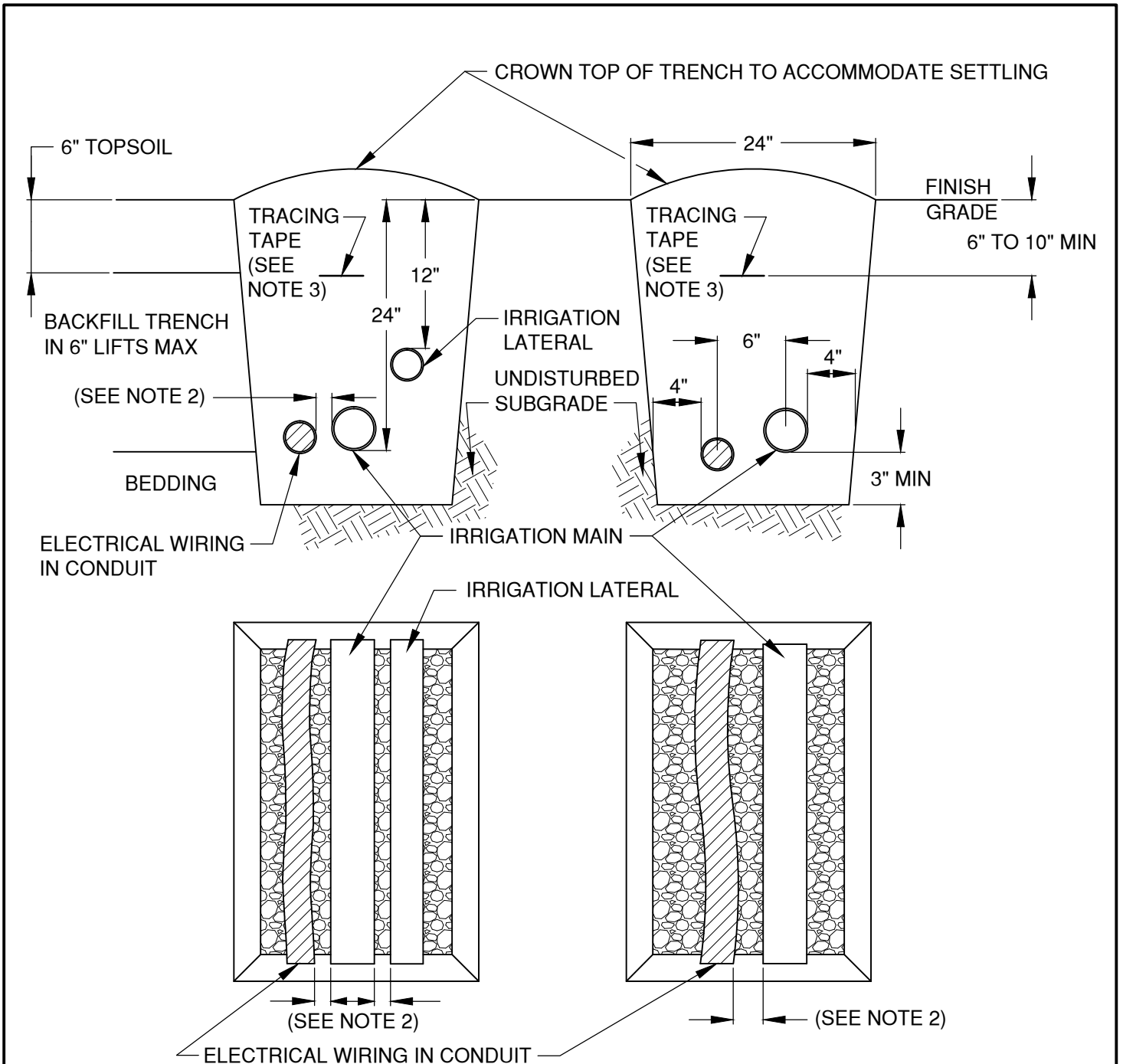

**NOTES:**

- 1. MINIMUM DEPTH OVER PVC PIPE:  
 10" FOR 1-1/4" OR SMALLER  
 12" FOR 1-1/2" TO 2" PIPE  
 14" FOR 2-1/2" TO 3" LATERALS  
 18" FOR MAINLINE PIPING AND SLEEVES
- 2. CLEARANCE BETWEEN PIPE:  
 4" FOR PIPE 2" AND SMALLER  
 6" FOR LARGER PIPE
- 3. PROVIDE A DETECTABLE TAPE OR WIRE USING A CONTINUOUS MINIMUM 14 GAUGE SINGLE STRAND LOCATOR WIRE IN TRENCH A MINIMUM 6" TO 10" BELOW FINISH GRADE. TRACING TAPE OR WIRE SHALL BE LOCATED A MINIMUM 6" ABOVE PIPING ON MAINLINE INSTALLATIONS

DRAWN LJC	
DIV LNDSCP	
REV	DATE



**CITY OF BEND**  
 STANDARD DRAWING  
 710 NW WALL ST., BEND, OREGON 97701

**IRRIGATION - TYPICAL TRENCH**

SCALE NTS
DATE 12/1/17
APPR
STD DWG L-4

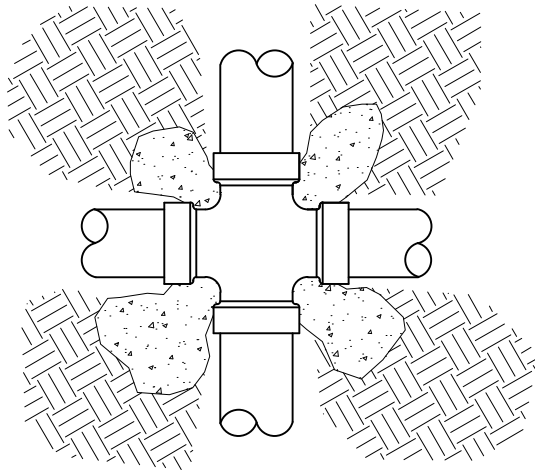

CROSS

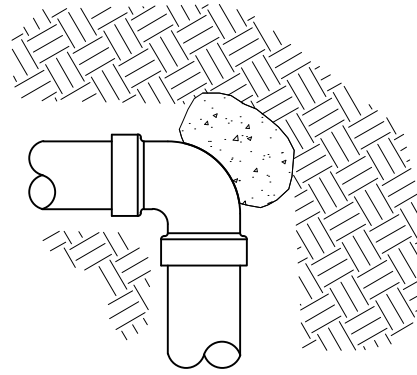

ELL

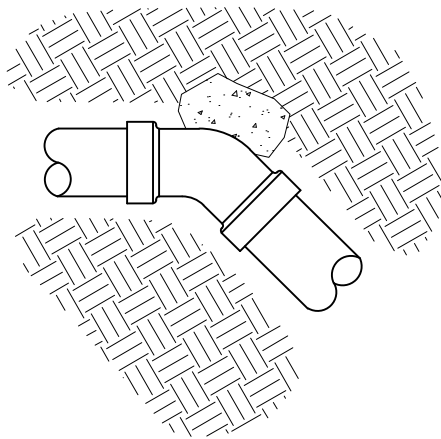

45° ELL

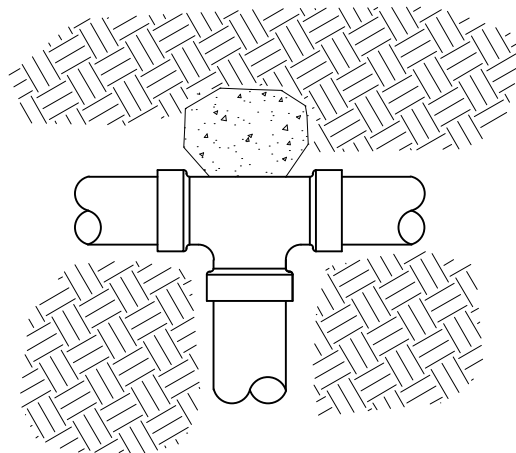

TEE

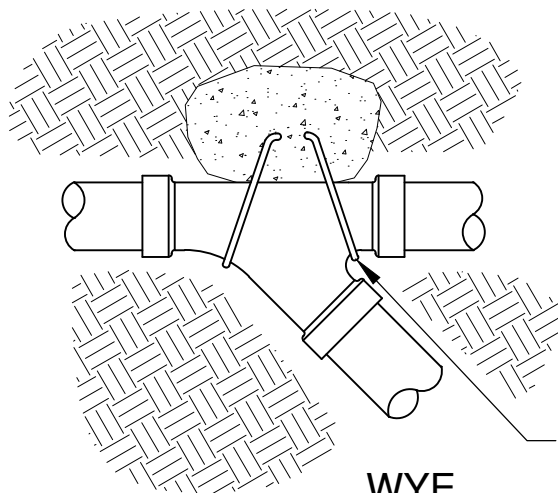

WYE

REBAR LOOP TIE

NOTES:

1. SUPPLY LINES 3" IN DIAMETER AND LARGER SHALL RECEIVE THRUST BLOCKS
2. USE A MINIMUM 1 CU FT OF CONCRETE IN EACH THRUST BLOCK POUR

DRAWN LJC	
DIV LNDSCP	
REV	DATE



CITY OF BEND

CITY OF BEND

STANDARD DRAWING

710 NW WALL ST., BEND, OREGON 97701

IRRIGATION FITTINGS

SCALE NTS

DATE 12/1/17

APPR

STD DWG L-5

- 1 30" LINEAR LENGTH OF WIRE, COILED
- 2 WATER PROOF CONNECTION (1 OF 2)
- 3 ID TAG
- 4 VALVE BOX WITH COVER: AMETEK STANDARD OR EQUAL
- 5 FINISH GRADE/TOP OF MULCH ALLOW 2" DEPTH MIN FOR BARK IF LOCATED IN SHRUB BED

- 6 REMOTE CONTROL VALVE: AS SPECIFIED ON DRAWING
- 7 PVC SCHEDULE 40 PIPE
- 8 PVC SADDLE FEMALE THREAD
- 9 TREATED WOOD OR BRICK SUPPORT (LENGTH AS REQ'D.)
- 10 CONTROL WIRING 24 VAC
- 11 PVC MAINLINE PIPE
- 12 SCH 80 MALE ADAPTER
- 13 PVC SCH 40
- 14 GRAVEL BED AT BOTTOM OF BOX 6" MIN DEPTH

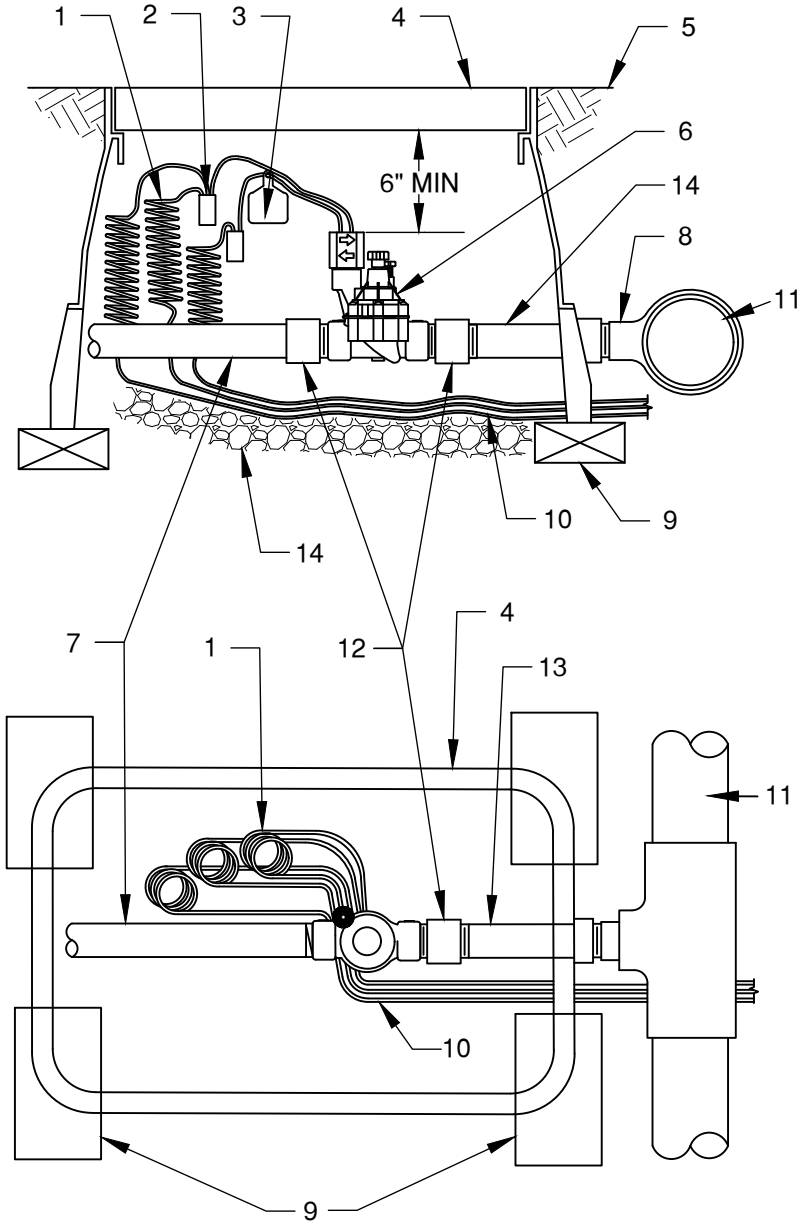

DRAWN LJC  
 DIV SANITARY  
 REV DATE



CITY OF BEND

CITY OF BEND  
 STANDARD DRAWING

710 NW WALL ST., BEND, OREGON 97701

IRRIGATION REMOTE CONTROL VALVE

SCALE NTS

DATE 04/16/2026

APPR

STD DWG L-6

PVC DRIPLINE FEEDER MANIFOLD (SEE DETAIL THIS SHEET)

AIR/VACUUM RELIEF VALVE (PLUMBED TO DRIPLINE AT EACH HIGH POINT)

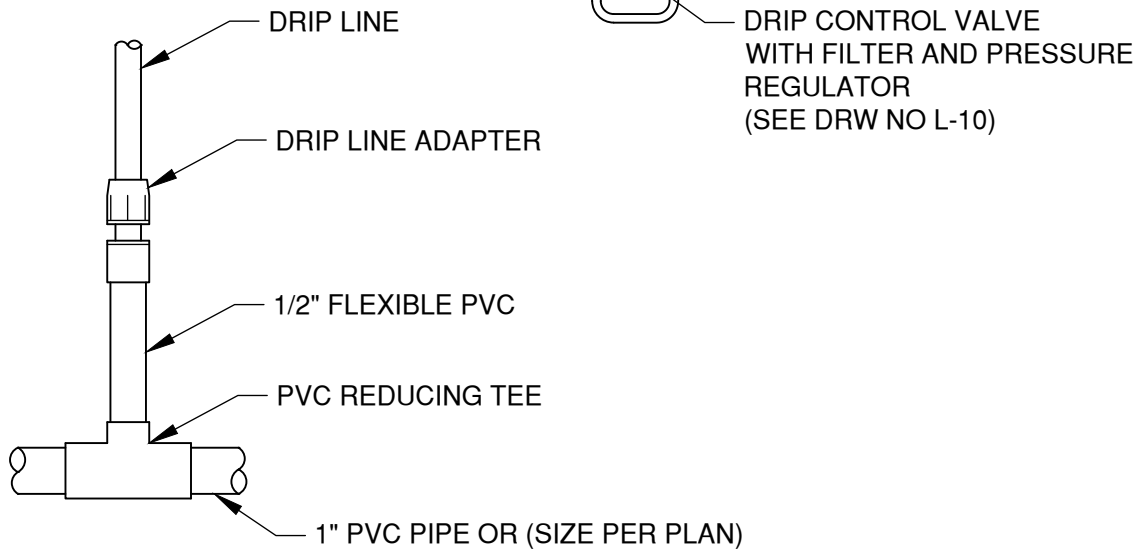
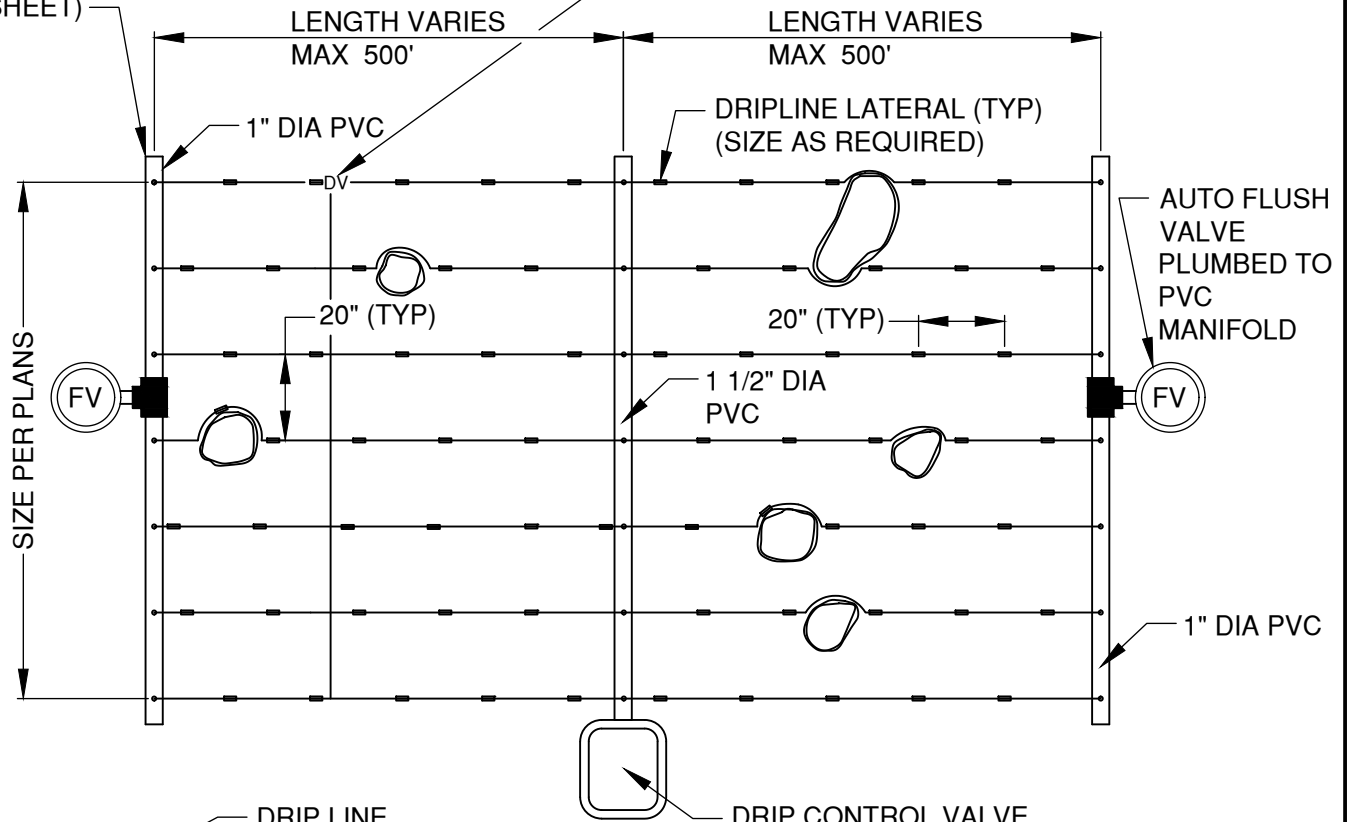

**TYPICAL PVC DRIPLINE MANIFOLD CONNECTION**

NOTES:

1. RELOCATE DRIP LINES AROUND OBSTACLES AS NEEDED

DRAWN	LJC
DIV	LNDSCLP
REV	DATE



**CITY OF BEND**  
STANDARD DRAWING  
710 NW WALL ST., BEND, OREGON 97701

SCALE	NTS
DATE	04/16/2026
APPR	
STD DWG	L-7

**PLANTING OR TURF BED DRIP LAYOUT**

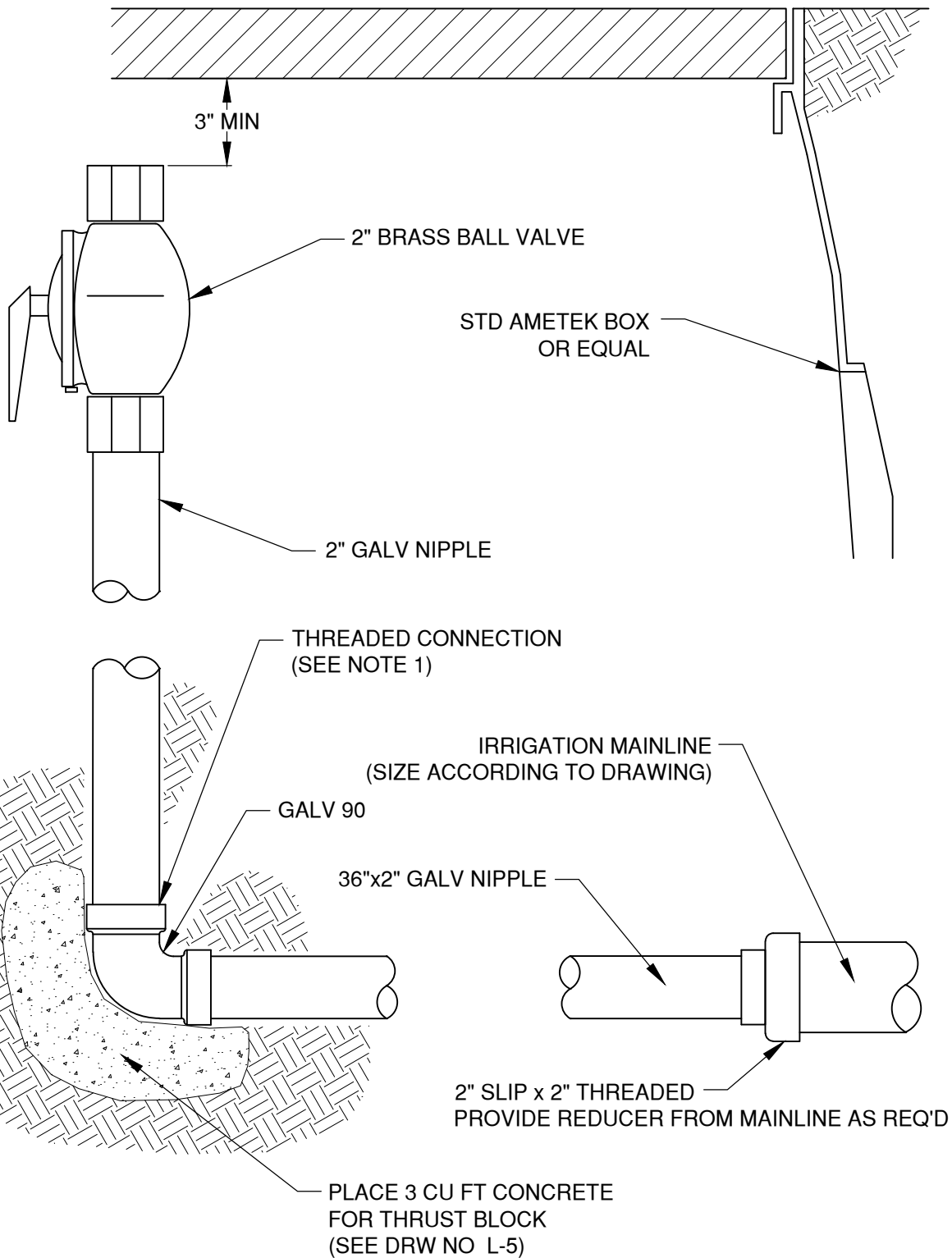

**NOTES:**

1. PROVIDE ALL THREADED CONNECTIONS WITH A NON-HARDENING, JOINT COMPOUND, COMPATIBLE WITH MANUFACTURERS RECOMMENDATION

DRAWN LJC	
DIV LNDSCP	
REV	DATE



**CITY OF BEND**

**CITY OF BEND**

STANDARD DRAWING

710 NW WALL ST., BEND, OREGON 97701

**TERMINATION POINT**

SCALE NTS

DATE 12/1/17

APPR

STD DWG L-8

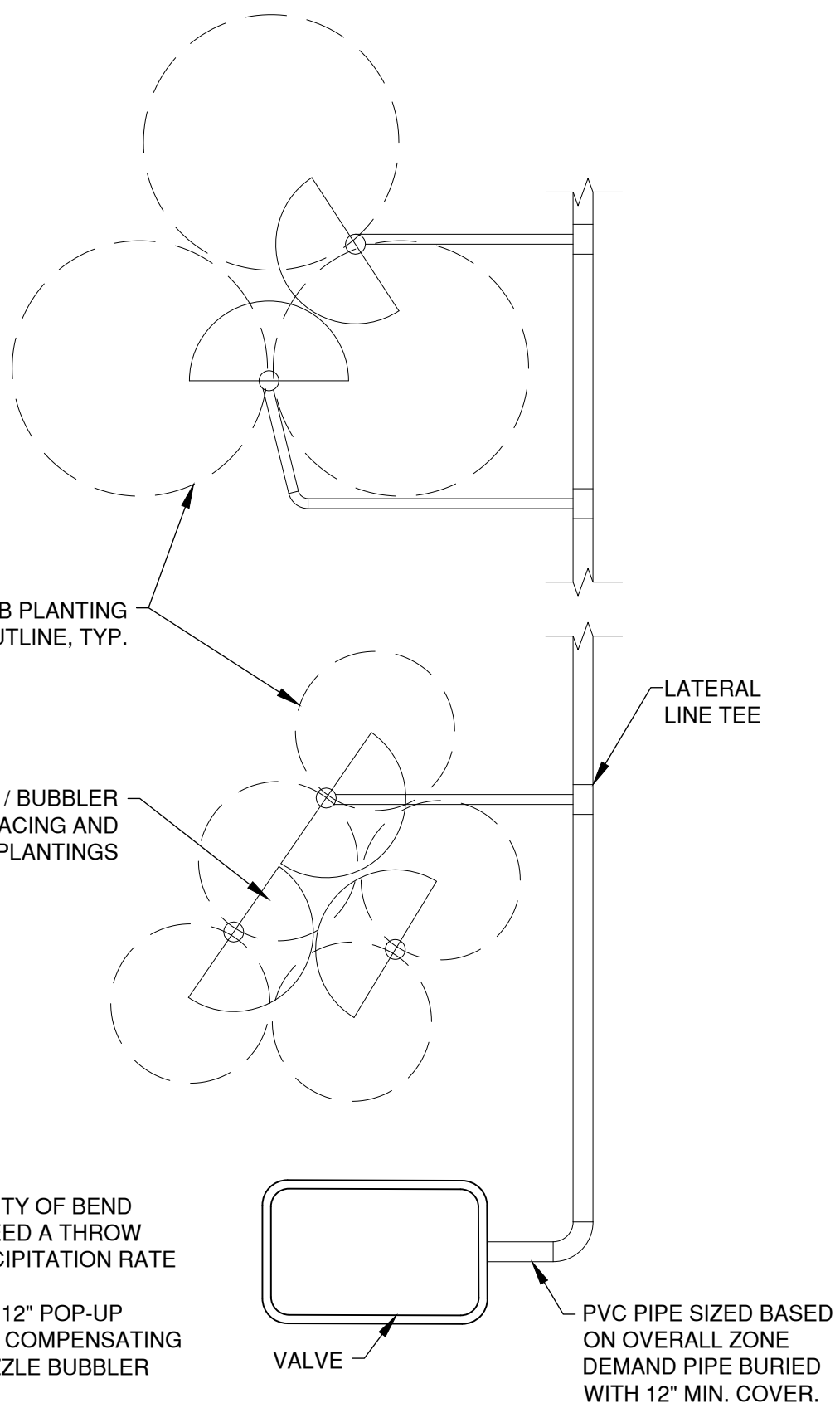

**NOTES:**

1. NOZZLE DEVICE TO MEET CITY OF BEND STANDARDS AND NOT EXCEED A THROW DISTANCE OF 4' AND A PRECIPITATION RATE UNDER 1" PER HOUR.
2. INSTALL NOZZLES ON 6" OR 12" POP-UP BODIES. UTILIZE PRESSURE COMPENSATING BODIES TO ALIGN WITH NOZZLE BUBBLER SELECTION.

PVC PIPE SIZED BASED ON OVERALL ZONE DEMAND PIPE BURIED WITH 12" MIN. COVER.

DRAWN ARS	
DIV LNDSCLP	
REV	DATE



**CITY OF BEND**  
 STANDARD DRAWING  
 710 NW WALL ST., BEND, OREGON 97701

**MULTI STREAM BUBBLER LAYOUT**

SCALE NTS
DATE 04/16/2026
APPR
STD DWG L-9

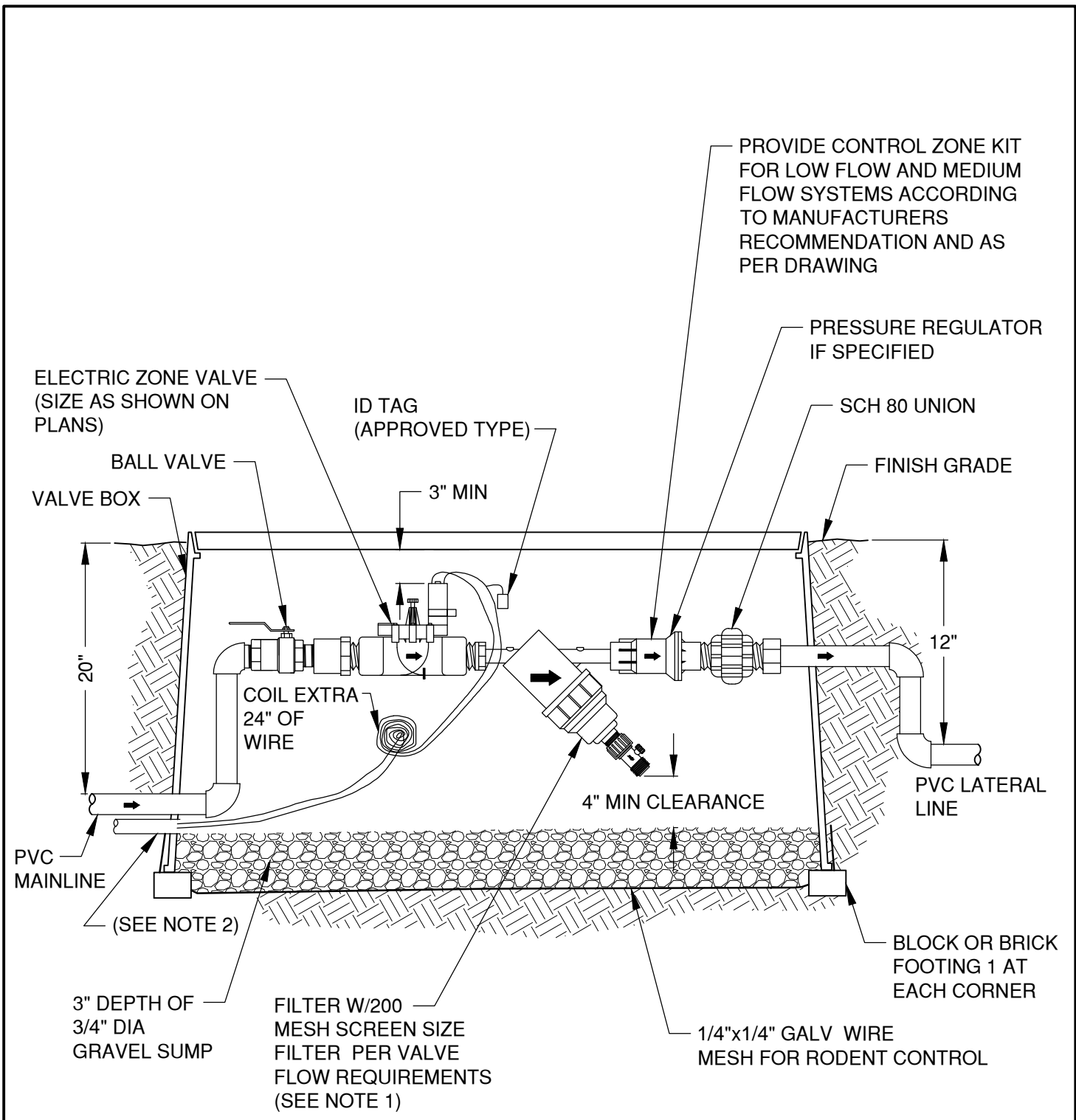

NOTES:

1. PROVIDE ADEQUATE SPACE FOR SERVICING THE SYSTEM
2. ALL ELECTRICAL WIRE TO BE INSTALLED IN APPROVED CONDUIT

DRAWN LJC	
DIV LNDSCP	
REV	DATE



**CITY OF BEND**  
 STANDARD DRAWING  
 710 NW WALL ST., BEND, OREGON 97701

**DRIP CONTROL VALVE, FILTER, AND REGULATOR**

SCALE NTS
DATE 12/1/17
APPR
STD DWG L-10

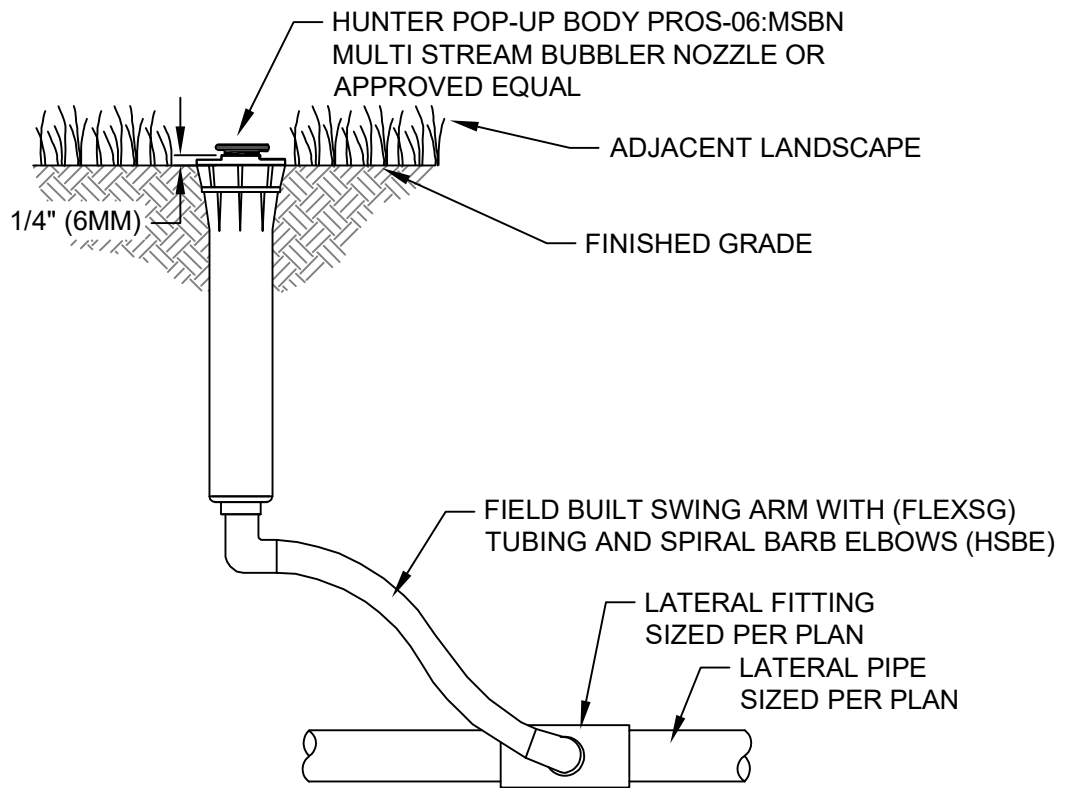

DRAWN CJH  
 DIV LNDSCP  
 REV DATE



CITY OF BEND

**CITY OF BEND**

STANDARD DRAWING

710 NW WALL ST., BEND, OREGON 97701

**MSBN MULTI-STREAM BUBBLER**

SCALE NTS

DATE 11/01/2024

APPR

STD DWG L-11

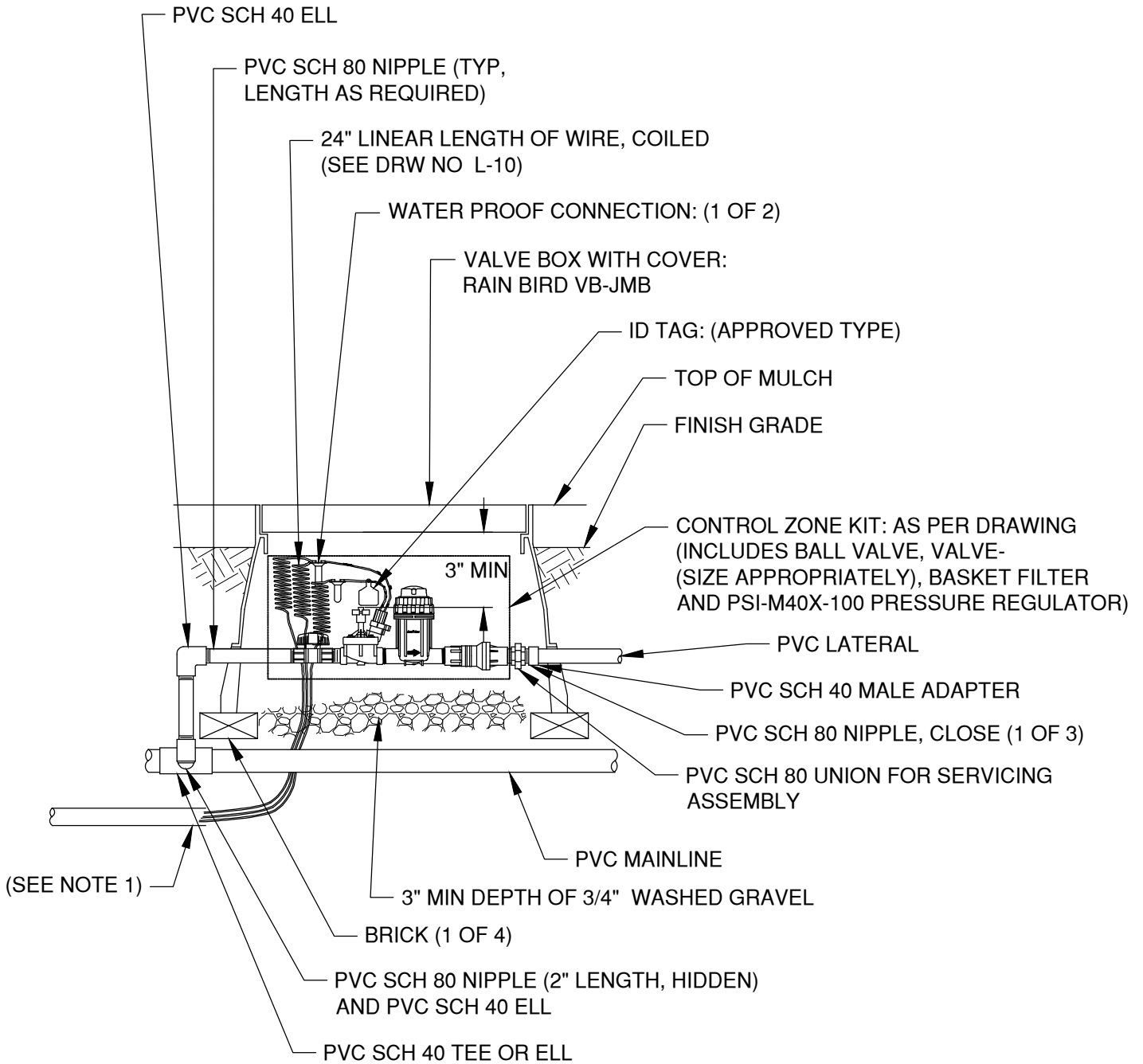

NOTES:

1. ALL ELECTRICAL WIRE TO BE INSTALLED IN APPROVED CONDUIT

DRAWN LJC	
DIV LNDSCP	
REV	DATE



CITY OF BEND

CITY OF BEND

STANDARD DRAWING

710 NW WALL ST., BEND, OREGON 97701

1" COMM. CONTROL ZONE KIT WITH BASKET FILTER

SCALE NTS

DATE 12/1/17

APPR

STD DWG L-12

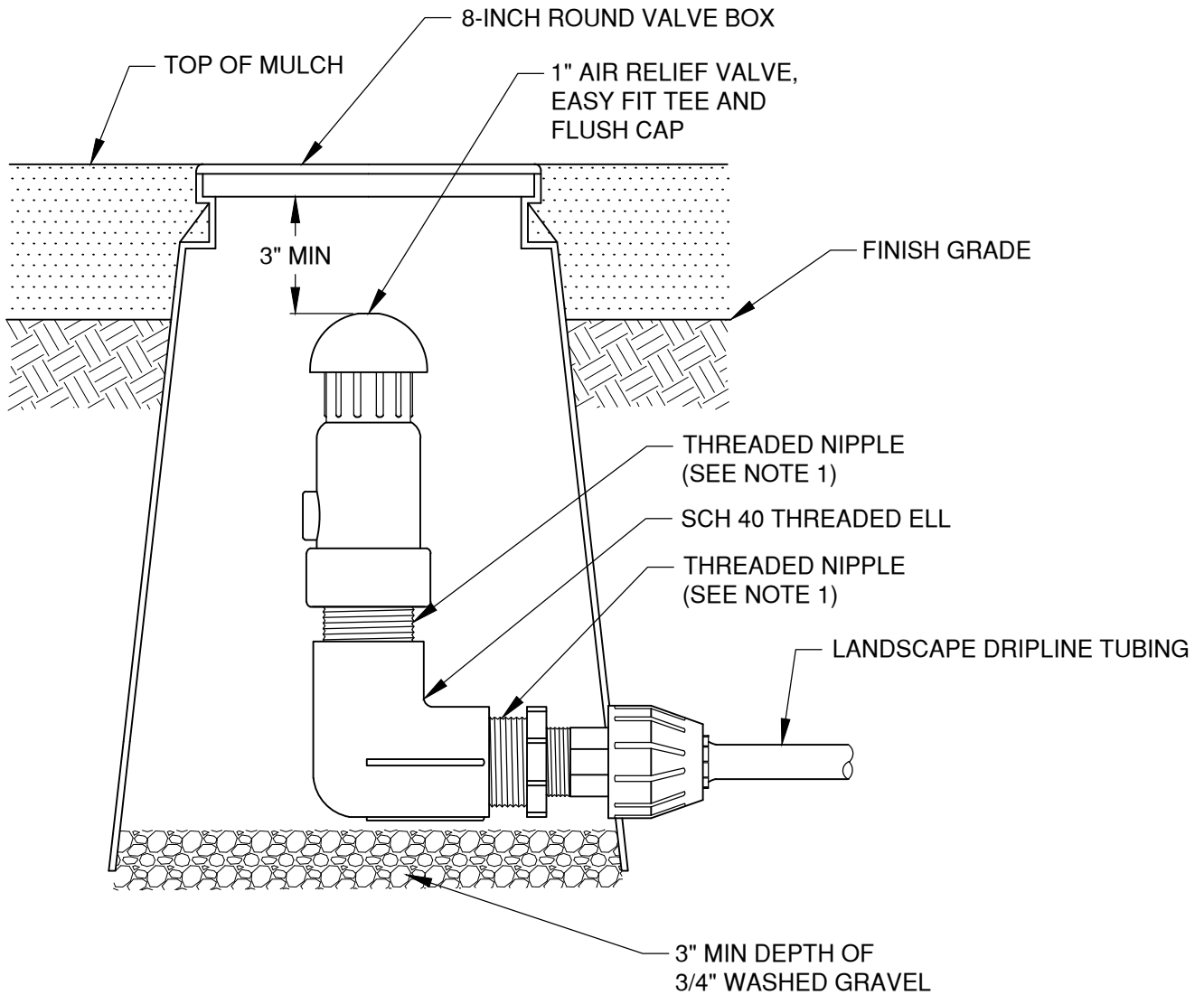

NOTES:

1. PROVIDE ALL THREADED CONNECTIONS WITH A NON-HARDENING, JOINT COMPOUND, COMPATIBLE WITH MANUFACTURERS RECOMMENDATIONS

DRAWN LJC	
DIV LNDSCP	
REV	DATE



CITY OF BEND

CITY OF BEND

STANDARD DRAWING

710 NW WALL ST., BEND, OREGON 97701

AIR RELIEF VALVE IN KIT - AR VALVE KIT

SCALE NTS

DATE 12/1/17

APPR

STD DWG L-13

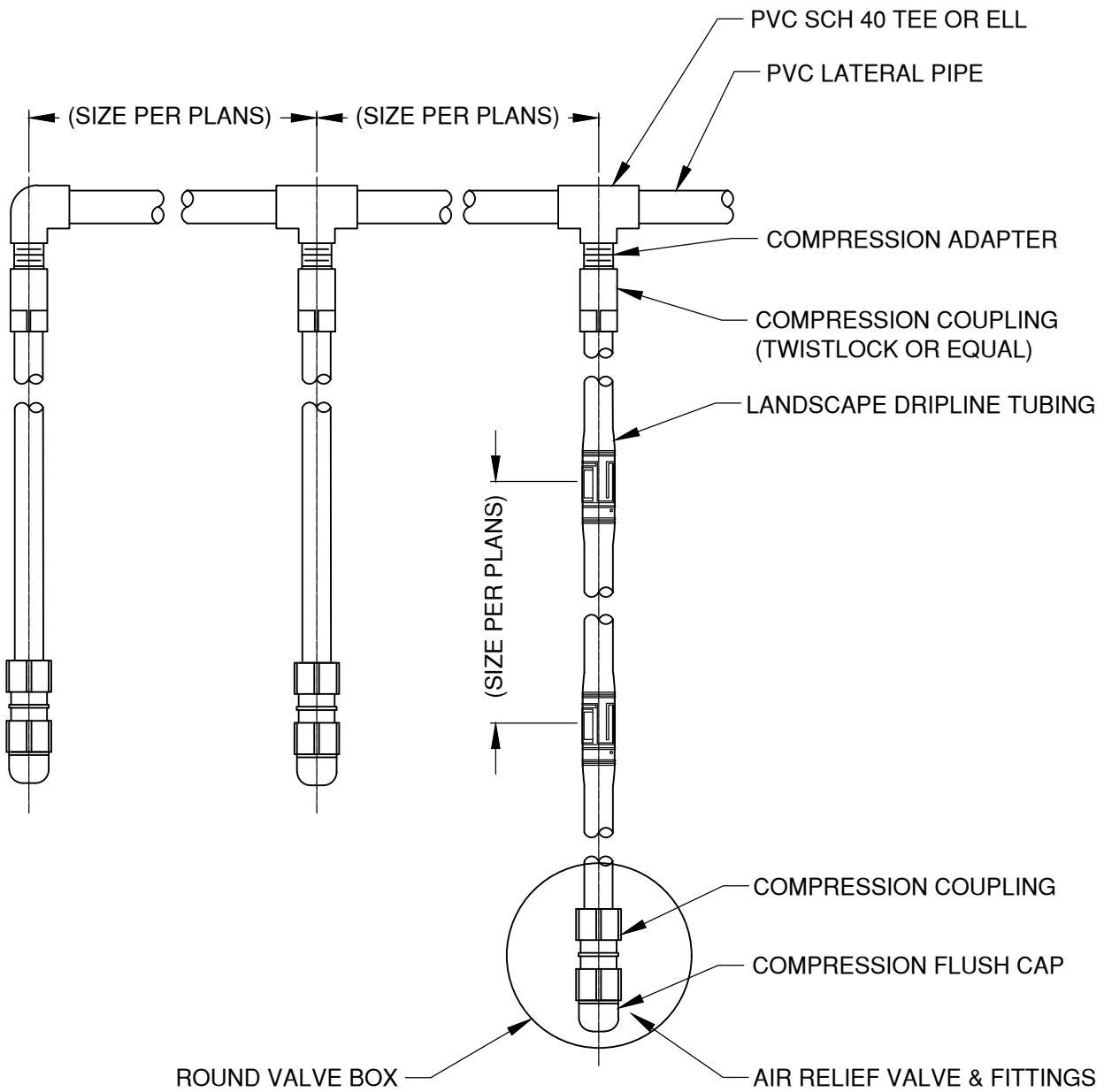

NOTES:

1. LATERAL AND EMITTER SPACING DEPENDS ON SOIL TYPE, AND PLANT SPECIES.
2. SEE OSS - DET 6110 - PLANTING OR TURF BED DRIP LAYOUT FOR OVERALL SPECIFICATION

DRAWN LJC	
DIV LNDSCP	
REV	DATE
1	12/10/21



**CITY OF BEND**  
 STANDARD DRAWING  
 710 NW WALL ST., BEND, OREGON 97701

**DRIP IRRIGATION MAINLINE LAYOUT**

SCALE NTS
DATE 12/1/17
APPR
STD DWG L-14

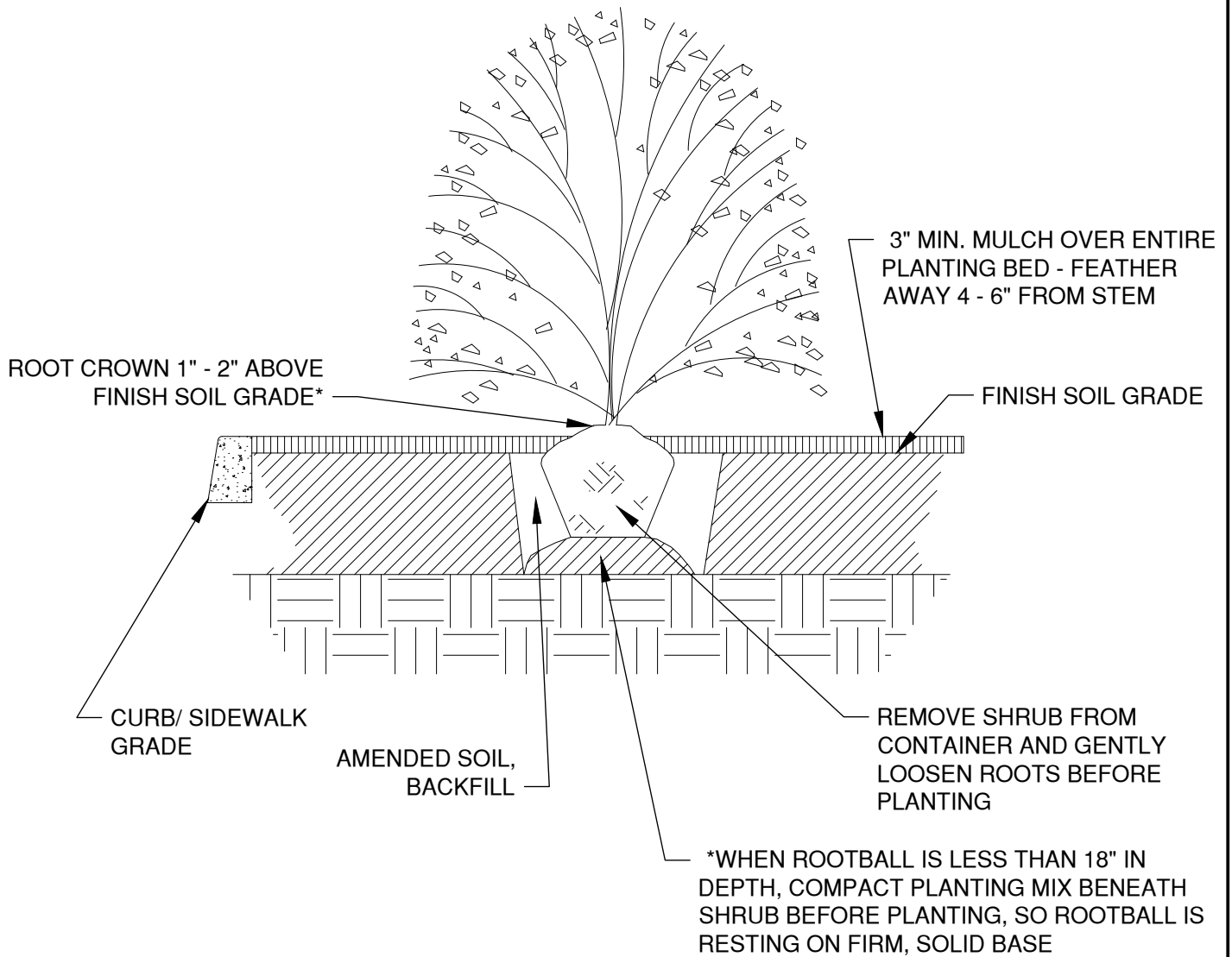

NOTES:

1. SHRUBS PLANTED OUTSIDE OF LANDSCAPE MEDIANS, I.E. IN ROADSIDES, SHALL BE PLANTED IN A PLANTING PIT.

DRAWN ARS	
DIV LNDSCLP	
REV	DATE



**CITY OF BEND**  
 STANDARD DRAWING  
 710 NW WALL ST., BEND, OREGON 97701  
**PLANTING DETAIL**

SCALE NTS
DATE 04/16/2026
APPR
STD DWG L-15

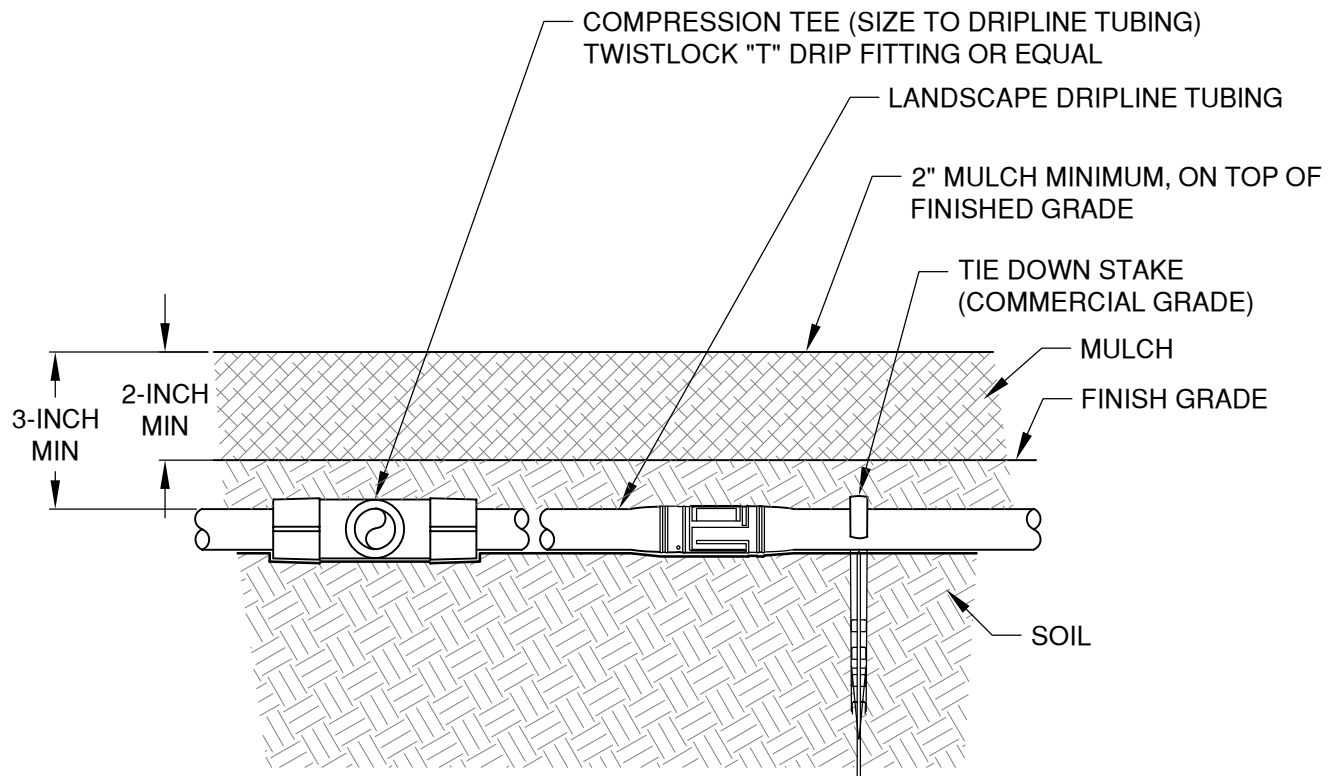

NOTES:

1. IF PUTTING LANDSCAPE DRIPLINE UNDER SOIL, DO NOT BURY MORE THAN 2" BELOW GRADE AND INCLUDE AIR RELIEF VALVE (SEE DRW NO L-13 "AIR RELIEF VALVE KIT-AR VALVE KIT")

DRAWN AJD	
DIV LNDSCP	
REV	DATE



CITY OF BEND

CITY OF BEND

STANDARD DRAWING

710 NW WALL ST., BEND, OREGON 97701

DRIPLINE 2" BELOW GRADE POTABLE SYSTEM

SCALE NTS

DATE 11/01/2024

APPR

STD DWG L-16

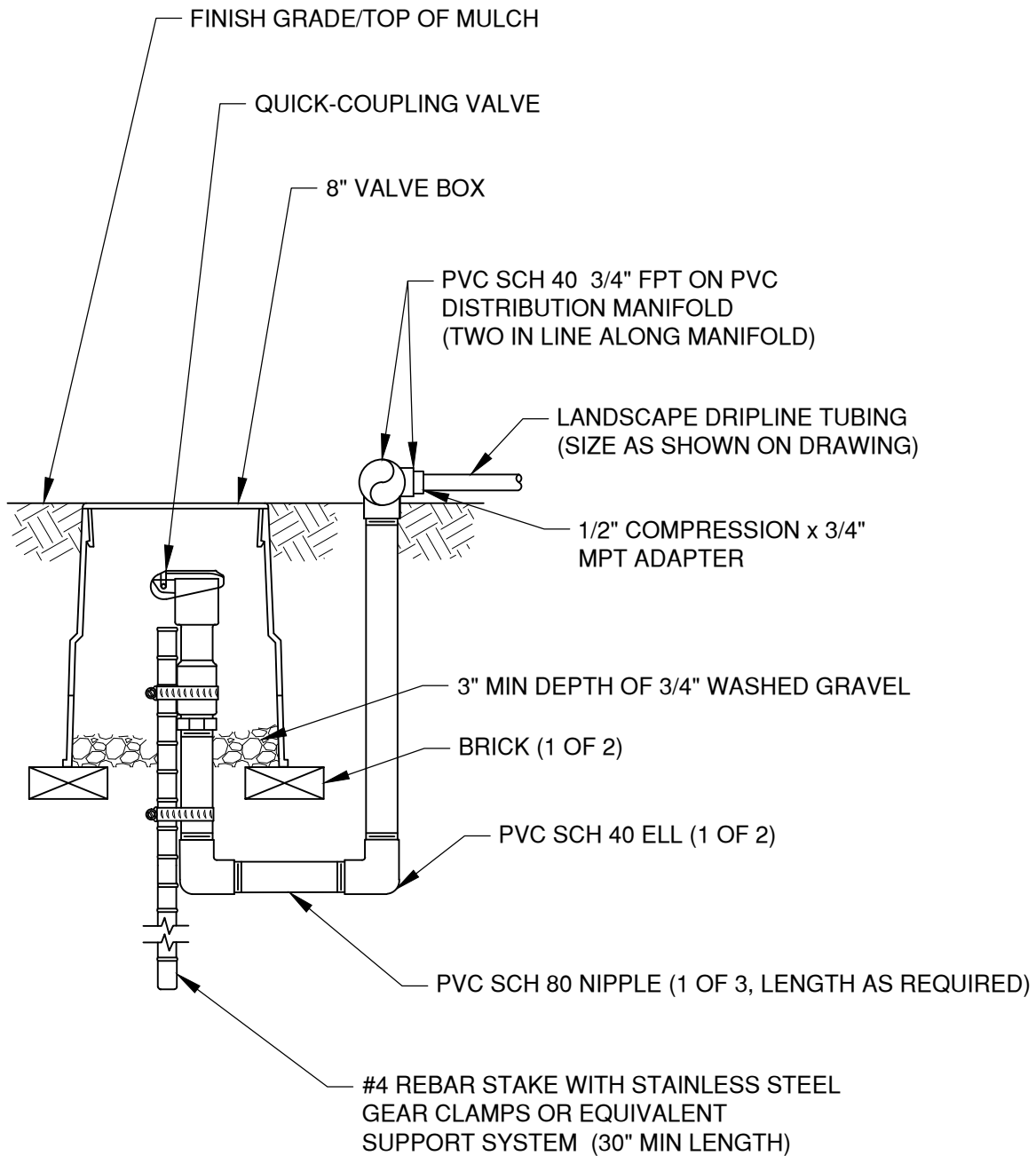

NOTES:

1. FURNISH FITTINGS AND PIPING NOMINALLY SIZED IDENTICAL TO NOMINAL QUICK COUPLING VALVE INLET SIZE

DRAWN LJC	
DIV LNDSCP	
REV	DATE



CITY OF BEND

CITY OF BEND

STANDARD DRAWING

710 NW WALL ST., BEND, OREGON 97701

SCALE NTS

DATE 12/1/17

APPR

STD DWG L-17

LANDSCAPE DRIPLINE FLUSH POINT POTABLE SYSTEM

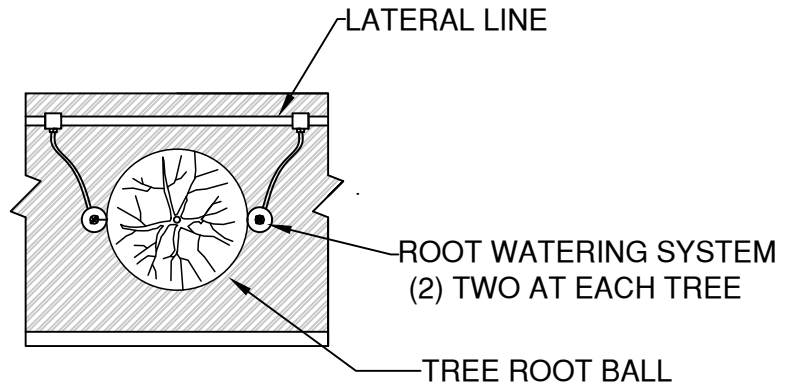

PLAN

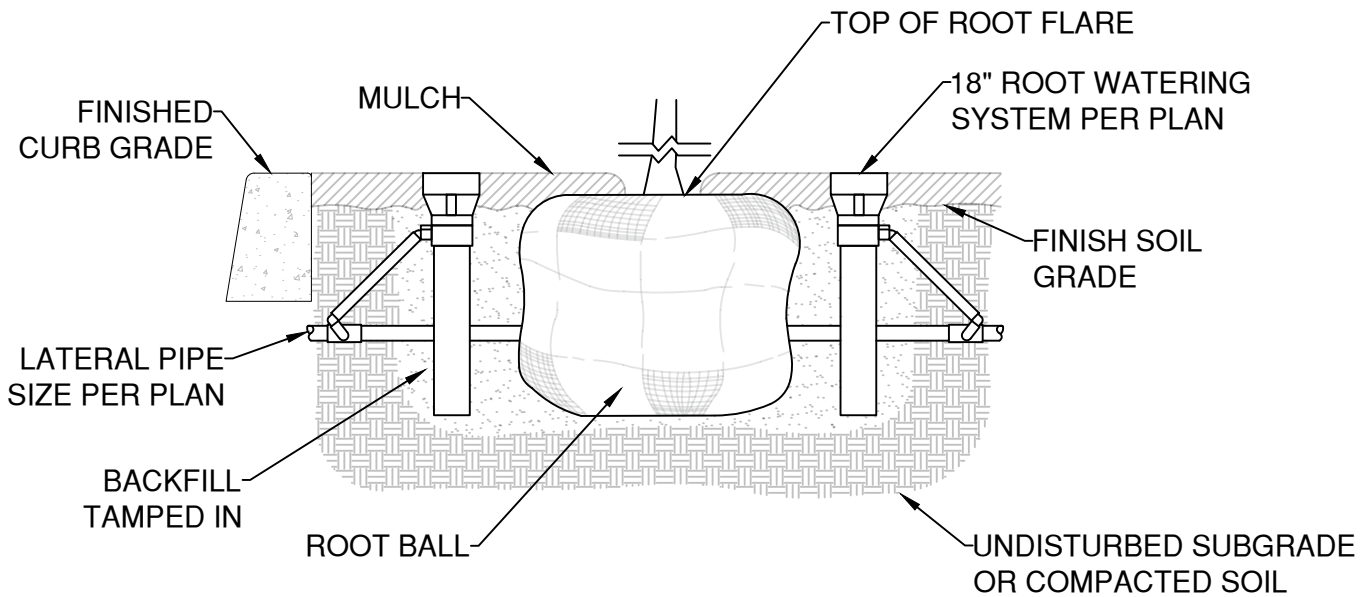

SECTION

NOTES:

1. POSITION UNITS EVENLY AND SPACED AROUND ROOT BALL OF TREE
2. INSTALL TOP OF ROOT WATER SYSTEM EVEN WITH TOP OF MULCH
3. INSTALL ONE ROOT WATERING SYSTEM WHEN SHOWN AS ONE ON PLAN SHEETS

DRAWN ARI	
DIV	
REV	DATE



**CITY OF BEND**  
 STANDARD DRAWING  
 710 NW WALL ST., BEND, OREGON 97701

**TREE ROOT WATERING SYSTEM DETAIL**

SCALE NTS
DATE 04/16/2026
APPR
STD DWG L-18

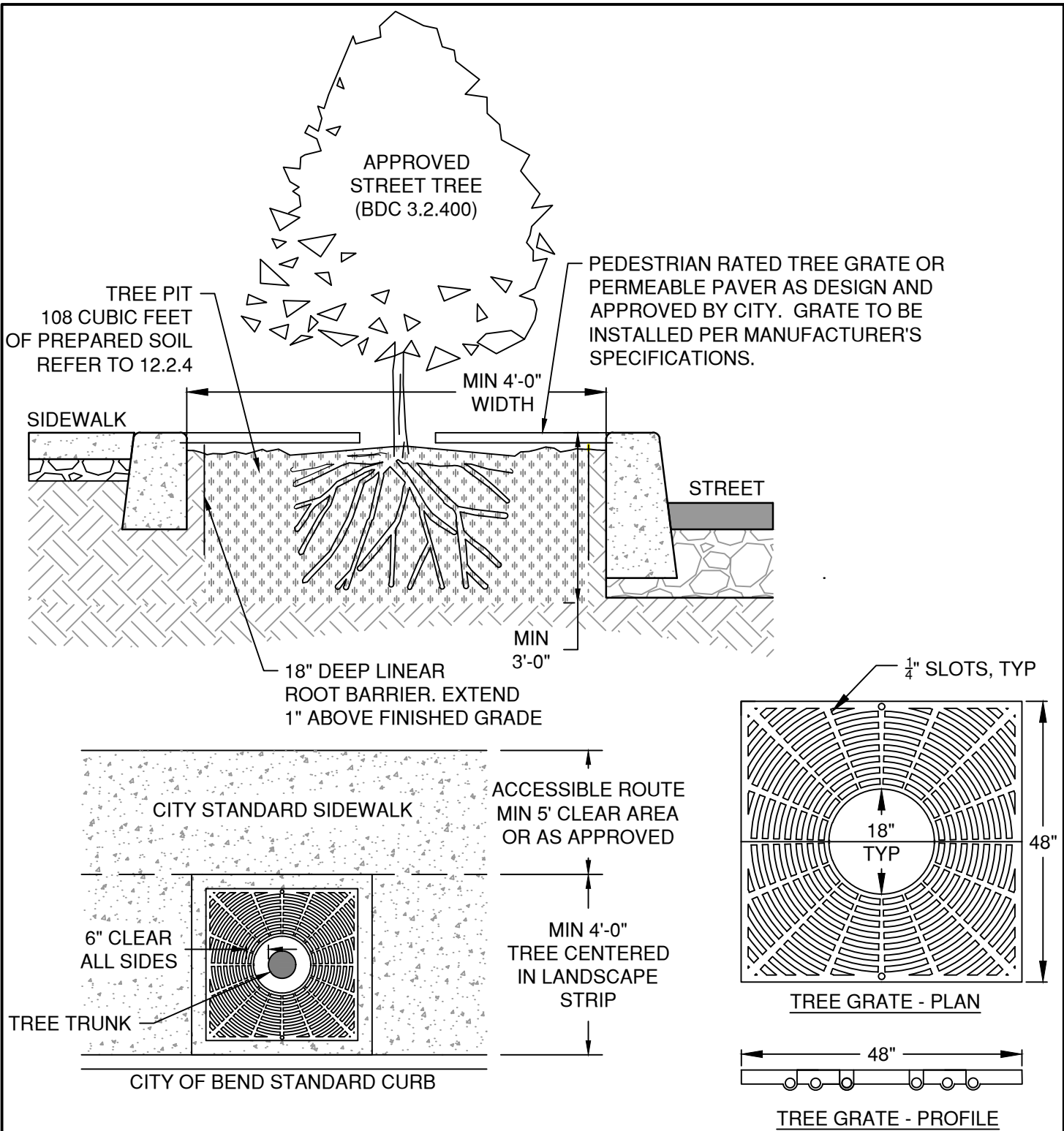

NOTES:

1. MINIMUM TREE WELL DIMENSIONS DICTATED BY BEND DEVELOPMENT CODE 12.2.4.1.
2. VEGETATION WITHIN THE TREE WELL SHALL HAVE DRIP SYSTEM IRRIGATION INSTALLED PER L-18.
3. TREE GRATE SHALL BE EJ 8954 PLAZA SET, OR APPROVED EQUAL.

DRAWN AJD	
DIV LNDSCP	
REV	DATE



CITY OF BEND

CITY OF BEND  
STANDARD DRAWING

710 NW WALL ST., BEND, OREGON 97701

TREE WELL DETAIL

SCALE NTS
DATE 01/31/2022
APPR
STD DWG L-19

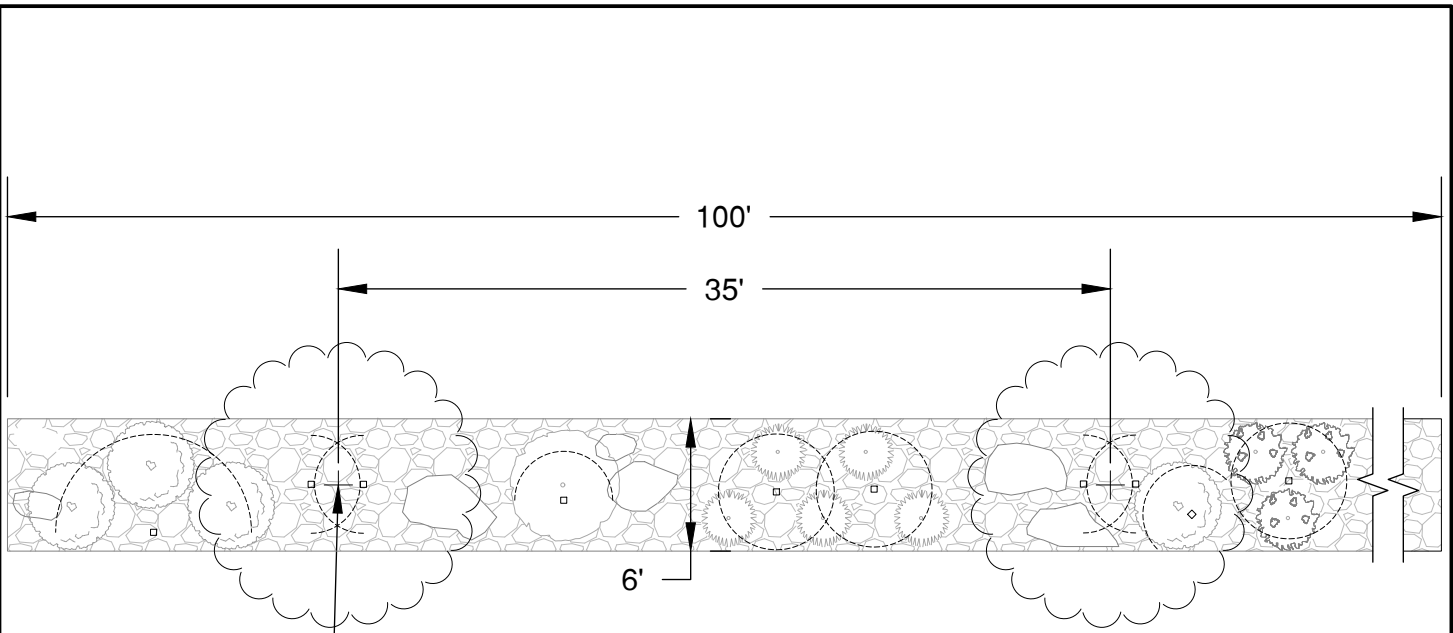

PLANT TREES IN CENTER OF MEDIAN

SPARSE PLANTING - LINEAR APPROACH  
CLUSTER GROUP EXAMPLE

CLUSTER SHRUBS IN GROUPS OF 3 OR 5

ROCK MULCH GROUND COVER OVER WEED BARRIER

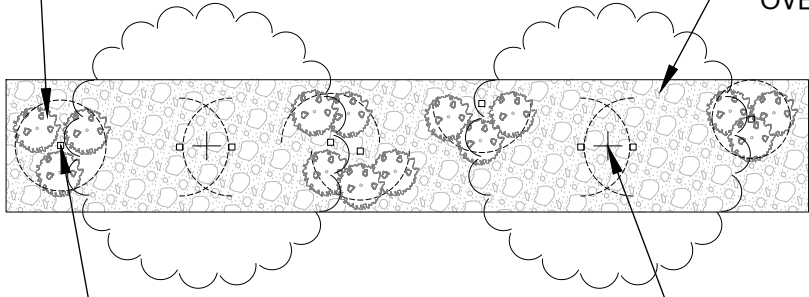

POP-UP STREAM BUBBLERS CENTERED IN SHRUB GROUPINGS

(2) RWS ROOT WATERING SYSTEM PER TREE, ON DEDICATED ZONE, INSTALLED OUTSIDE ROOTBALL

DRAWN ARS	
DIV LNDSCP	
REV	DATE



**CITY OF BEND**  
STANDARD DRAWING  
710 NW WALL ST., BEND, OREGON 97701

**PLANTING DISTRIBUTIONS AND IRRIGATION LAYOUT**

SCALE NTS
DATE 04/16/2026
APPR
STD DWG L-20

SLW WEATHER STATION, OR APPROVED EQUIVALENT, SYNCHRONIZE TO WEATHER STATION HUB IN CONTROLLER

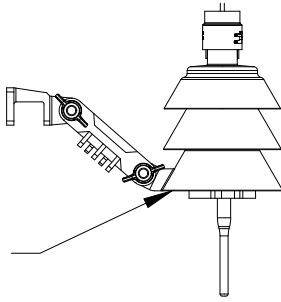

SL-HG-ANT-LTE

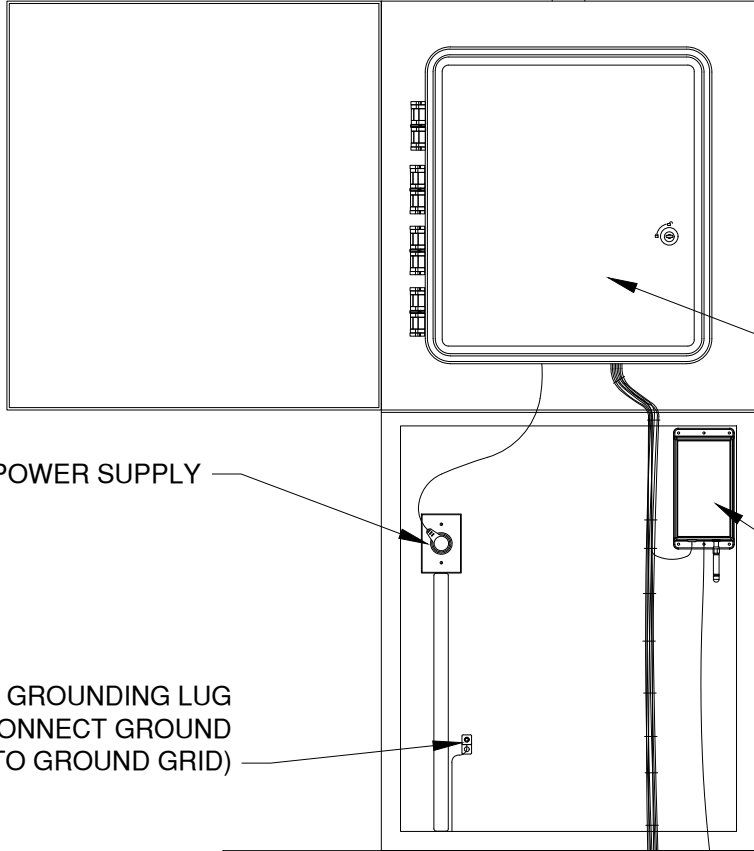

SLPED-ENC PEDESTAL CABINET OR APPROVED EQUIVALENT, SEE NOTE 1

SL SERIES CONTROLLER OR APPROVED EQUIVALENT

POWER SUPPLY

SL-AIRCARD OR APPROVED EQUIVALENT

GROUNDING LUG (CONNECT GROUND WIRE TO GROUND GRID)

FINISH GRADE

CONDUIT 115V A.C.

CONDUIT 24V A.C., MIN 3/4" DIA

POWER SUPPLY WIRES  
#8 SOLID INSULATED COPPER GROUND WIRE TO GROUND GRID

FLOW SENSOR CABLE

VALVE CONTROL WIRES, ONE PER VALVE

TO MASTER VALVE, OPTIONAL

NOTES:

- 1. STRONGBOX MPE WITH SB-1852SS, OR EQUIVALENT, MAY BE USED TO CONSOLIDATE COMPONENTS.

DRAWN ARS	
DIV LNDSCP	
REV	DATE



**CITY OF BEND**  
STANDARD DRAWING  
710 NW WALL ST., BEND, OREGON 97701

**IRRIGATION CONTROLLER ENCLOSURE**

SCALE NTS
DATE 04/16/2026
APPR
STD DWG L-21

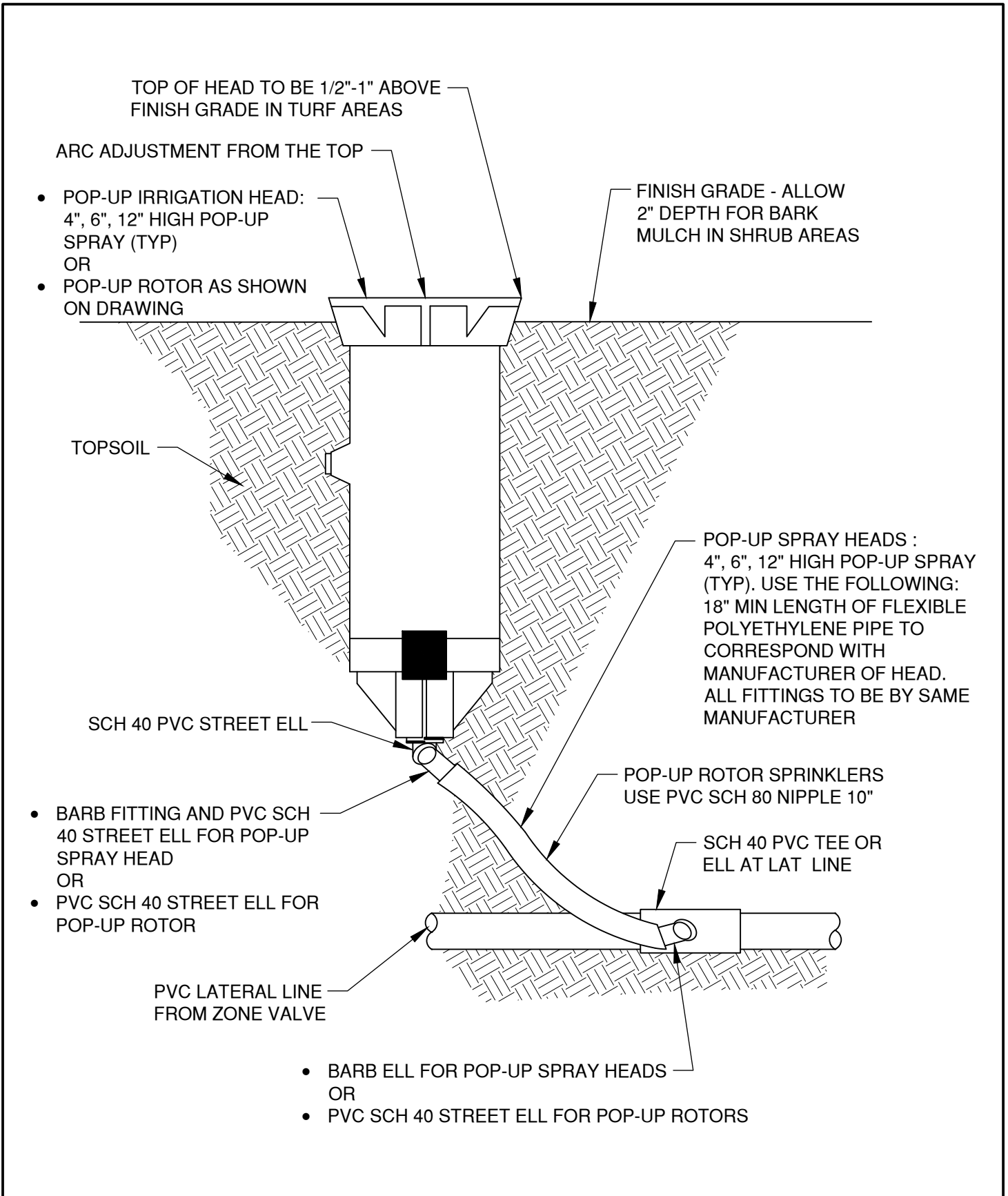

DRAWN LJC	
DIV LNDSCP	
REV	DATE



**CITY OF BEND**  
 STANDARD DRAWING  
 710 NW WALL ST., BEND, OREGON 97701

**SPRINKLER HEAD AND JOINTS**

SCALE NTS
DATE 04/16/2026
APPR
STD DWG L-23

---

**CITY OF BEND STANDARD DRAWINGS**

**Roadway (R)**

---

GENERAL NOTES FOR STD DWGS R-1A THROUGH R-1H:

1. CENTER STREETS IN THE RIGHT-OF-WAY UNLESS OTHERWISE APPROVED BY CITY ENGINEER FOR UNIQUE TRANSITIONS OR SITE CONSTRAINTS.
2. THE LEVEL OF TRAFFIC STRESS PER THE ODOT APM CH. 14 IS SHOWN ON EACH STANDARD CROSS-SECTION. MODIFICATION OF THE CROSS-SECTIONS MUST PROVIDE THE APPROPRIATE LTS.
3. INSTALL SIDEWALKS/SHARED-USE PATHS PROPERTY TIGHT. SIDEWALKS/SHARED-USE PATHS MAY MEANDER AROUND UTILITIES, TREES, AND OTHER NON-MOVEABLE OBJECTS. METERS, MANHOLES, AND VALVES ARE NOT PERMITTED WITHIN THE SIDEWALK UNLESS OTHERWISE APPROVED BY THE CITY ENGINEER. EXCEPTIONS WILL ONLY BE PERMITTED IF SIDEWALK CANNOT MEANDER AROUND THE EXISTING CONSTRAINT, OR THE OBSTACLE CANNOT BE REMOVED/RELOCATED. EASEMENTS ARE REQUIRED WHERE SIDEWALK/SHARED-USE PATH MEANDERS OUT OF THE RIGHT-OF-WAY.
4. PAVEMENT SECTIONS FOR STREETS AND SIDEWALKS PER THE THICKNESSES NOTED IN TABLE BELOW OR AS SPECIFIED IN A STAMPED GEOTECHNICAL REPORT APPROVED BY THE CITY ENGINEER.
5. RETAINING WALLS AND STAIRS ARE NOT PERMITTED WITHIN THE RIGHT-OF-WAY UNLESS OTHERWISE APPROVED BY THE CITY ENGINEER.
6. STREET CROSS-SECTION/IMPROVEMENT STANDARDS ARE BASED ON STREET CLASSIFICATION. REFERENCE THE BEND DEVELOPMENT CODE SECTION 3.4 PUBLIC IMPROVEMENTS STANDARDS AND STANDARD CROSS-SECTIONS FOR ADDITIONAL DETAIL.
7. THE CROSS-SLOPE OF THE PLANTER STRIP BETWEEN THE CURB AND RIGHT-OF-WAY SHALL NOT BE STEEPER THAN 4H:1V TO PROVIDE A RECOVERABLE ROADSIDE SLOPE. 50H:1V (2%) IS TYPICAL/PREFERRED.
8. MAX 1.5H:1V CUT SLOPES PERMITTED IN ROCK CUTS WHEN APPROVED BY A GEOTECHNICAL ENGINEER.
9. MASTER PLAN DEVELOPMENTS PER BEND DEVELOPMENT CODE 4.5.100(E)(2)(C) MAY PROPOSE MODIFIED STREET SECTIONS THAT INCLUDE ADDITIONS TO OR ENHANCEMENTS OF THE BASIC MINIMUM STANDARD SECTIONS SHOWN HERE.
10. OFF STREET SHARED-USE PATHS (PATHS MEETING THE GENERAL ALIGNMENT OF THE TSP LOW STRESS NETWORK AND ARE MORE THAN 30 FT OUTSIDE OF THE RIGHT-OF-WAY) ARE ENCOURAGED, PARTICULARLY ALONG ARTERIAL STREET CORRIDORS. SIDEWALKS MAY BE REDUCED TO A MINIMUM 6 FT OR ELIMINATED WHEN THE SAME SIDE OF THE ROAD CORRIDOR IS SERVED BY A SHARED-USE PATH DEPENDING ON ADJACENT LAND USE AND PEDESTRIAN/BIKE ACCESS AND WITH CITY ENGINEER APPROVAL.
11. TWELVE-FOOT CENTER MEDIAN ON ARTERIAL AND COLLECTOR CROSS-SECTIONS INCLUDES EITHER A STRIPED MEDIAN (TWO-WAY LEFT TURN LANE, DOUBLE YELLOW, AND/OR TURN BAY) OR A NINE-FOOT RAISED REFUGE ISLAND WITH A ONE AND A HALF FOOT SHY LINE STRIPE EACH SIDE AS REQUIRED PER STANDARDS.
12. RAISED MEDIANS ARE AT THE CITY ENGINEER'S DISCRETION ON ARTERIALS & COLLECTORS. MEDIAN REFUGE ISLANDS FOR STREET CROSSINGS ON A LOW STRESS ROUTE OR AN ENHANCED CROSSING ON A CONNECTOR ROUTE DO NOT REQUIRE CITY ENGINEER APPROVAL.
13. ON-STREET PARKING SPACES ARE NOT STRIPED. IN HIGH PARKING DEMAND AREAS, A PARKING LINE MAY BE USED WITH CITY ENGINEER APPROVAL.
14. SEE BEND DEVELOPMENT CODE 3.4.200(F)(3) FOR STREETS AND INTERSECTIONS NOT IDENTIFIED FOR TRAVEL LANE EXPANSION WHERE ADDITIONAL RIGHT-OF-WAY IS NOT REQUIRED FOR VEHICLE TRAVEL LANES.
15. PLTS = PEDESTRIAN LEVEL OF TRAFFIC STRESS / BLTS = BICYCLISTS LEVEL OF TRAFFIC STRESS.
16. DEVIATIONS FROM THE PAVEMENT SECTIONS PROVIDED IN THE TABLE BELOW REQUIRE A STAMPED GEOTECHNICAL REPORT. PCC ROADWAYS REQUIRE A STAMPED GEOTECHNICAL REPORT.
17. SEE CITY SPEC 00744/00745 FOR MAXIMUM AC PAVEMENT LIFT THICKNESS.
18. WHERE EXISTING GROUND CROSS SLOPE EXCEEDS 12%, CURB-TIGHT SIDEWALK IS ALLOWED PER DESIGN STANDARD 3.4.7 - HILLSIDE.

STREET TYPE	"A" ROW	"B" STREET	"C" SIDEWALK	"D" CURB	"E" ACP DEPTH/LEVEL	"F" BASE	"G" CUT/FILL
ARTERIAL	PER R-1A			7"/16"	8" - LEVEL III	10"	4H:1V
COLLECTOR	PER R-1B & R-1C			6"/14"	6" - LEVEL III	8"	4H:1V
LOCAL	PER R-1D & R-1E			6"/12"	4" - LEVEL III	6"	2H:1V
INDUSTRIAL LOCAL	PER R-1F			6"/12"	4" - LEVEL III	8"	2H:1V
ALLEY	PER R-1G			--	4" - LEVEL III	6"	2H:1V
ROUNDAABOUT - ACP	VARIES	VARIES	VARIES	**	8" - LEVEL IV	10"	4H:1V
ROUNDAABOUT - PCC ***	VARIES	VARIES	VARIES	**	*	*	4H:1V

\* THE STANDARD PAVEMENT SECTION FOR ARTERIAL STREETS IS ASPHALT. FOR RECONSTRUCTION, NEW STREETS MORE THAN 1/4 MILE LONG, AND FOR ROUNDABOUTS, A LIFE CYCLE COST ANALYSIS EVALUATING ASPHALT, PERPETUAL PAVEMENT, CONCRETE, AND OTHER SECTIONS SHALL BE SUBMITTED TO AND APPROVED BY THE CITY ENGINEER.

\* CURBS AT ROUNDABOUTS AND ON SPLITTER ISLANDS SHALL BE HIGH-STRENGTH PER CITY SPEC 00759.13.

\*\*\* DOWELING REQUIRED AT ROUNDABOUT JOINTS

DRAWN AJD		<p align="center"><b>CITY OF BEND</b> STANDARD DRAWING 710 NW WALL ST., BEND, OREGON 97701</p>	SCALE NTS
DIV ROADWAY			DATE 01/31/2022
REV DATE			APPR
<p align="center"><b>CITY OF BEND</b></p>		<p align="center"><b>TYPICAL STREET CROSS-SECTIONS - GENERAL NOTES</b></p>	STD DWG R-1

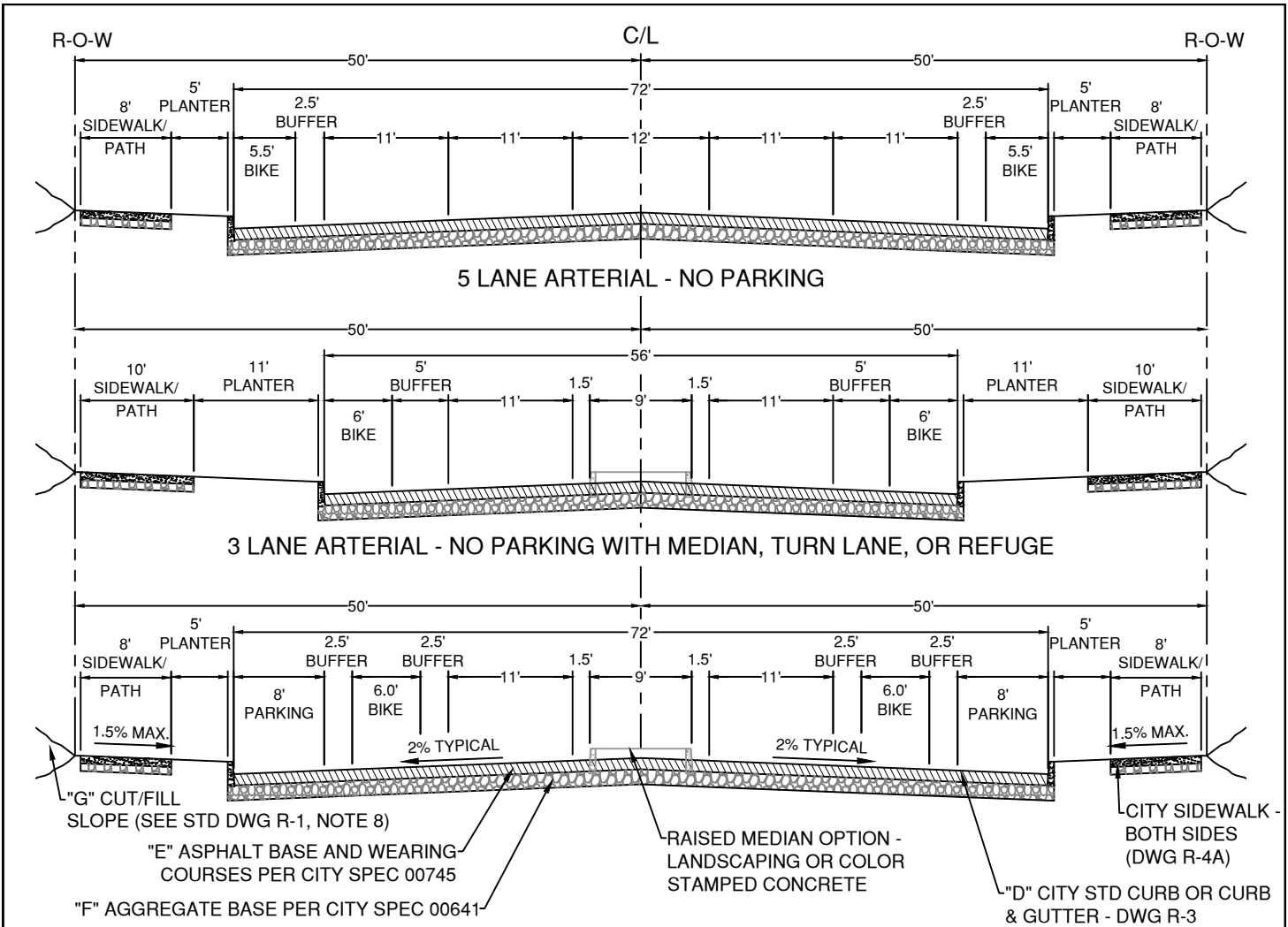

**3 LANE ARTERIAL - PARKING BOTH SIDES WITH MEDIAN, TURN LANE, OR REFUGE**

PLTS: 1 ≤ 35 MPH	BLTS: 1	BLTS: 1 ≤ 30 MPH
2 ≥ 40 MPH	(SUP)	(BIKE LANE) 2 = 35 MPH
		3 ≥ 40 MPH

**ARTERIAL GENERAL NOTES:**

- SEE R-1 FOR GENERAL NOTES.
- WHERE PERMITTED BY THE BEND DEVELOPMENT CODE, ON-STREET PARKING MAY BE PROVIDED ON ARTERIAL STREETS WITH SPEEDS 35 MPH OR LESS. ON-STREET PARKING DESIGN PER ENGINEERING STANDARDS.
- PROTECTED BIKE LANES, OTHER THAN PARKING PROTECTED, REQUIRE CITY ENGINEER APPROVAL. PARKING PROTECTED BIKE LANES ALLOWED ON A CASE-BY-CASE BASIS.
- SIDEWALK MAY MEANDER WITH A MINIMUM 5 FT PLANTER STRIP. DESIGN MEANDERING CURVES FOR 10 MPH.
- FOR EXISTING ARTERIAL SECTIONS IN 100 FT RIGHT-OF-WAY WITH 52 FT PAVEMENT WIDTHS, THE CITY ENGINEER MAY APPROVE REDUCING THE BIKE LANE TO 6/2.5 FT TO MATCH THE 52 FT CURB-TO-CURB EXISTING CONSTRUCTED SECTIONS; EXCEPTION DOES NOT APPLY TO SECTIONS (NEW OR RECONSTRUCTED) AT THE OUTER EXTENTS OF THE NETWORK WHERE UNDEVELOPED LAND AND FUTURE EXPANSIONS/RECONSTRUCTIONS CAN ACCOMMODATE THE 56/72 FT PAVEMENT SECTION.
- THE FIVE-LANE ARTERIAL SECTION IS TO BE USED ON 3RD STREET, 27TH STREET SOUTH OF NEFF ROAD, REED MARKET ROAD EAST OF US 97, AND OTHER MAJOR ARTERIAL STREETS AS IDENTIFIED BY A TRAFFIC ANALYSIS WITH CITY ENGINEER APPROVAL (SEE STANDARDS FOR LANE ADDITIONS).
- PARKING IS NOT PERMITTED ON A FIVE LANE ARTERIAL.
- FOR PARKING ON ONE SIDE OF A THREE LANE ARTERIAL, COMBINE THE APPLICABLE HALF STREET SECTIONS FROM THE NO PARKING AND PARKING ON BOTH SIDES TYPICAL SECTIONS. THE ROAD CENTERLINE SHALL REMAIN IN THE CENTER OF ROW TO ALLOW FOR FUTURE EXPANSION.

DRAWN	AJD
DIV	ROADWAY
REV	DATE



**CITY OF BEND**  
STANDARD DRAWING  
710 NW WALL ST., BEND, OREGON 97701

**TYPICAL STREET CROSS-SECTIONS - ARTERIAL**

SCALE	NTS
DATE	01/31/2022
APPR	
STD DWG	R-1A

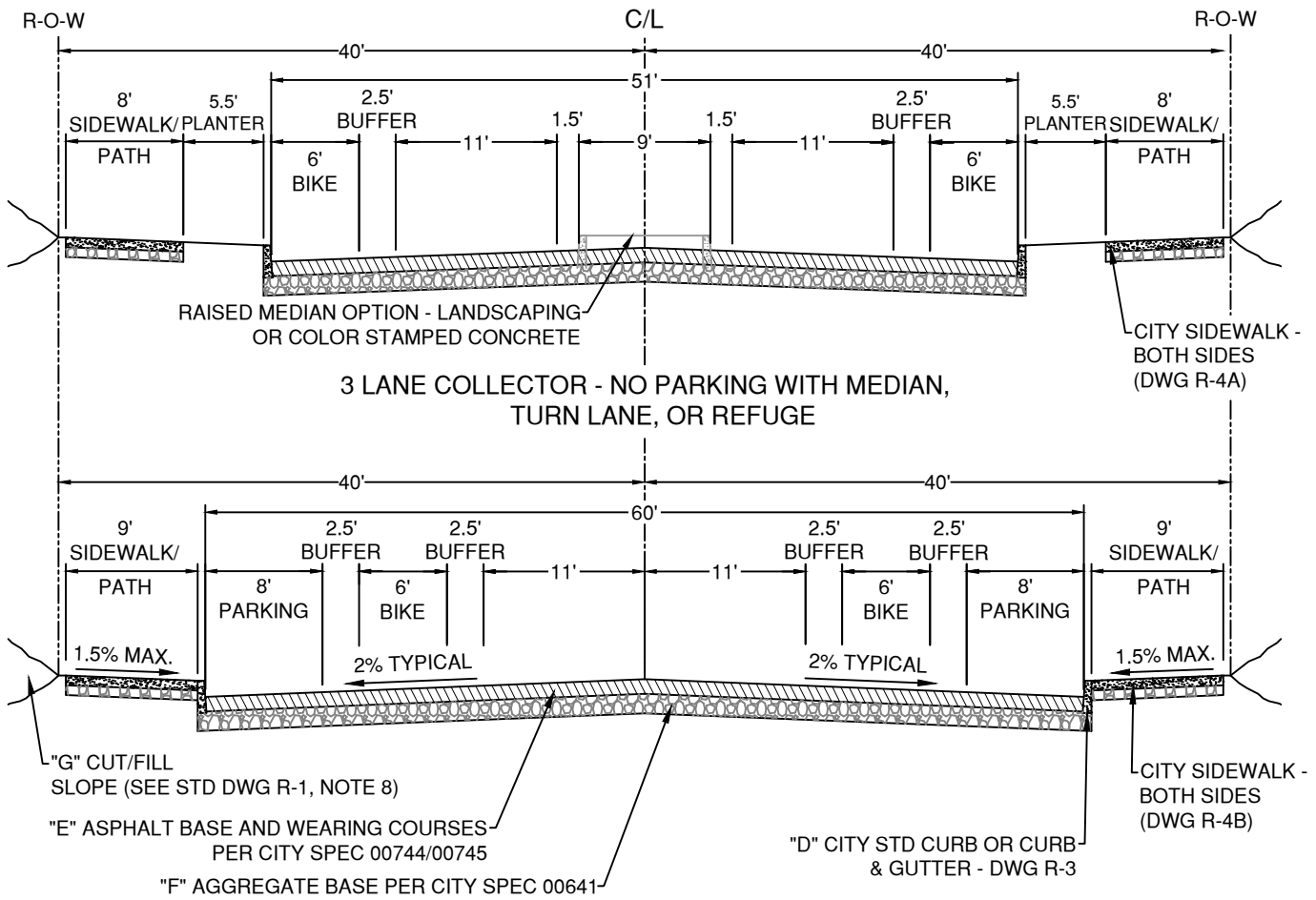

PLTS: 1 ≤ 35 MPH	BLTS: 1	BLTS: 1 ≤ 30 MPH
2 ≥ 40 MPH	(SUP)	(BIKE LANE) 2 = 35 MPH
		3 ≥ 40 MPH

**MAJOR COLLECTOR GENERAL NOTES:**

- SEE R-1 FOR GENERAL NOTES.
- WHERE PERMITTED BY THE BEND DEVELOPMENT CODE, ON-STREET PARKING MAY BE PROVIDED ON COLLECTOR STREETS WITH SPEEDS 35 MPH OR LESS. ON-STREET PARKING DESIGN PER ENGINEERING STANDARDS.
- WHERE THE CROSS-SECTION DOES NOT PROVIDE FOR TREES IN A PLANTER STRIP, DEVELOPMENT MUST STILL MEET BEND DEVELOPMENT CODE TREE REQUIREMENTS IN AN ALTERNATE LOCATION ON-SITE OR PROVIDE MITIGATION AND RECEIVE APPROVAL OF A VARIANCE AS REQUIRED BY CODE.
- PROTECTED BIKE LANES, OTHER THAN PARKING PROTECTED, REQUIRE CITY ENGINEER APPROVAL. PARKING PROTECTED BIKE LANES ALLOWED ON A CASE-BY-CASE BASIS.
- SIDEWALK MAY MEANDER WITH A MINIMUM 5 FT PLANTER STRIP. DESIGN MEANDERING CURVES FOR 10 MPH.

DRAWN	AJD
DIV	ROADWAY
REV	DATE



**CITY OF BEND**

**CITY OF BEND**  
STANDARD DRAWING

710 NW WALL ST., BEND, OREGON 97701

**TYPICAL STREET CROSS-SECTIONS - MAJOR COLLECTOR**

SCALE	NTS
DATE	07/02/2025
APPR	
STD DWG	R-1B

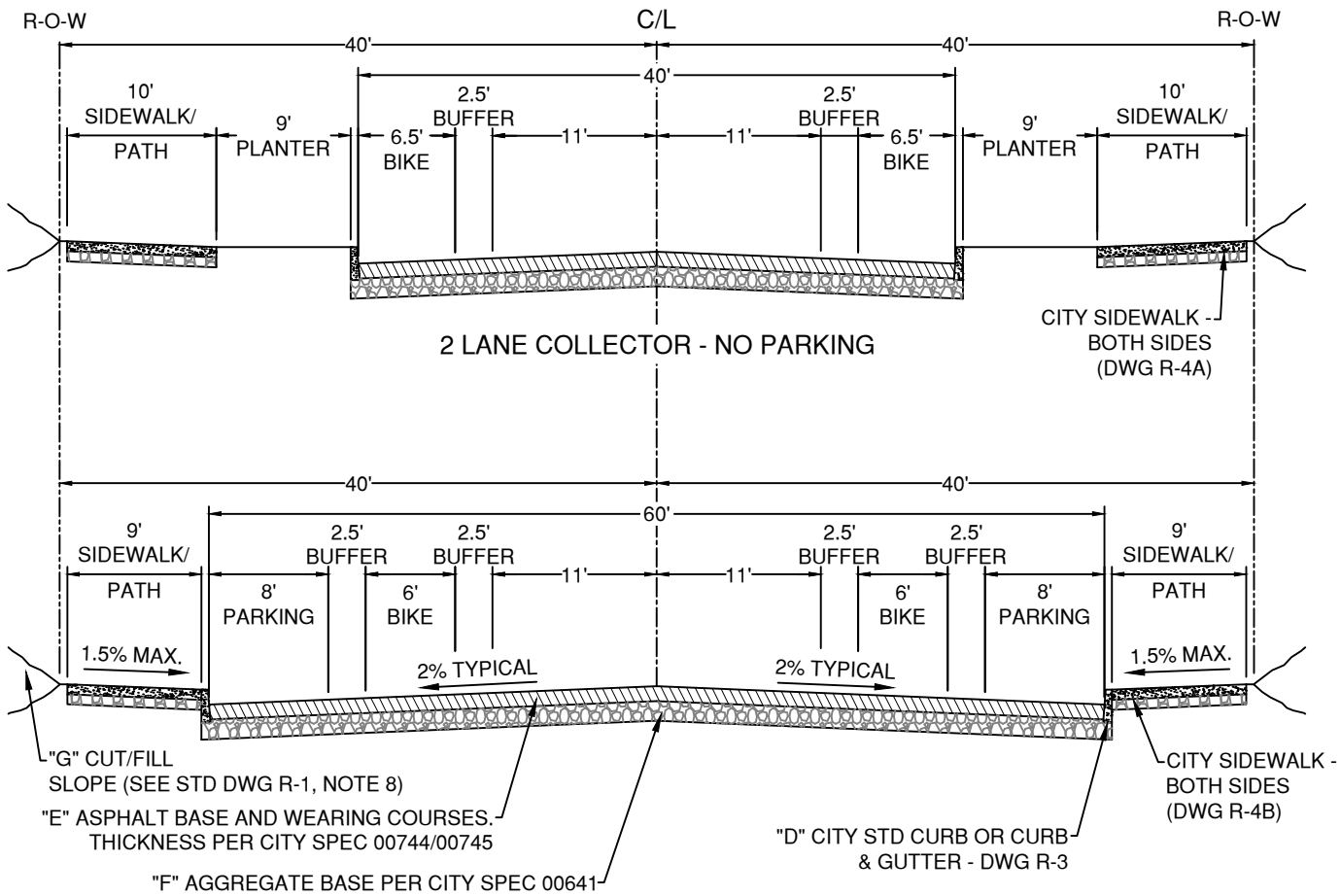

PLTS: 1 ≤ 35 MPH 2 ≥ 40 MPH	BLTS: 1 (SUP)	BLTS: 1 ≤ 30 MPH (BIKE LANE) 2 = 35 MPH 3 ≥ 40 MPH
--------------------------------	------------------	--

**MINOR COLLECTOR GENERAL NOTES:**

1. SEE R-1 FOR GENERAL NOTES.
2. WHERE PERMITTED BY THE BEND DEVELOPMENT CODE, ON-STREET PARKING MAY BE PROVIDED ON COLLECTOR STREETS WITH SPEEDS 35 MPH OR LESS. ON-STREET PARKING DESIGN PER ENGINEERING STANDARDS.
3. WHERE THE CROSS-SECTION DOES NOT PROVIDE FOR TREES IN A PLANTER STRIP, DEVELOPMENT MUST STILL MEET BEND DEVELOPMENT CODE TREE REQUIREMENTS IN AN ALTERNATE LOCATION ON-SITE OR PROVIDE MITIGATION AND RECEIVE APPROVAL OF A VARIANCE AS REQUIRED BY CODE.
4. PROTECTED BIKE LANES, OTHER THAN PARKING PROTECTED, REQUIRE CITY ENGINEER APPROVAL. PARKING PROTECTED BIKE LANES ALLOWED ON A CASE-BY-CASE BASIS.
5. SIDEWALK MAY MEANDER WITH A MINIMUM 5 FT PLANTER STRIP. DESIGN MEANDERING CURVES FOR 10 MPH.
6. FOR PARKING ON ONE SIDE, COMBINE THE APPLICABLE HALF STREET SECTIONS FROM THE NO PARKING AND PARKING ON BOTH SIDES TYPICAL SECTIONS. THE ROAD CENTERLINE SHALL REMAIN IN THE CENTER OF ROW TO ALLOW FOR FUTURE EXPANSION.

DRAWN <b>AJD</b>	DIV <b>ROADWAY</b>
REV	DATE



**CITY OF BEND**

**CITY OF BEND**  
STANDARD DRAWING

710 NW WALL ST., BEND, OREGON 97701

**TYPICAL STREET CROSS-SECTIONS - MINOR COLLECTOR**

SCALE <b>NTS</b>
DATE <b>07/02/2025</b>
APPR
STD DWG <b>R-1C</b>

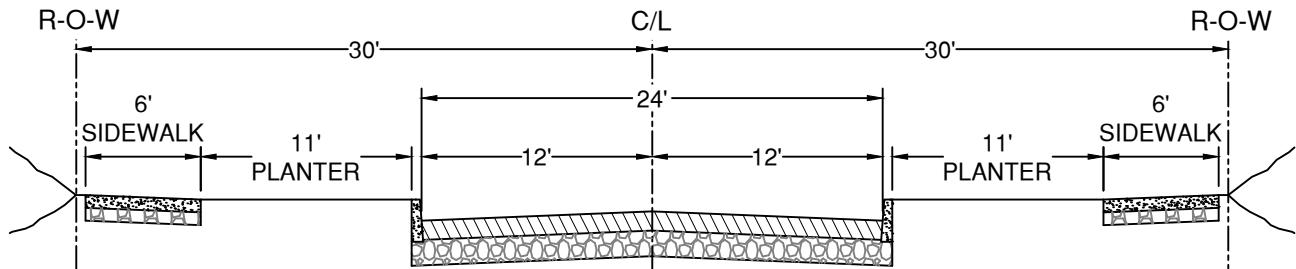

LOCAL ROAD - NO PARKING

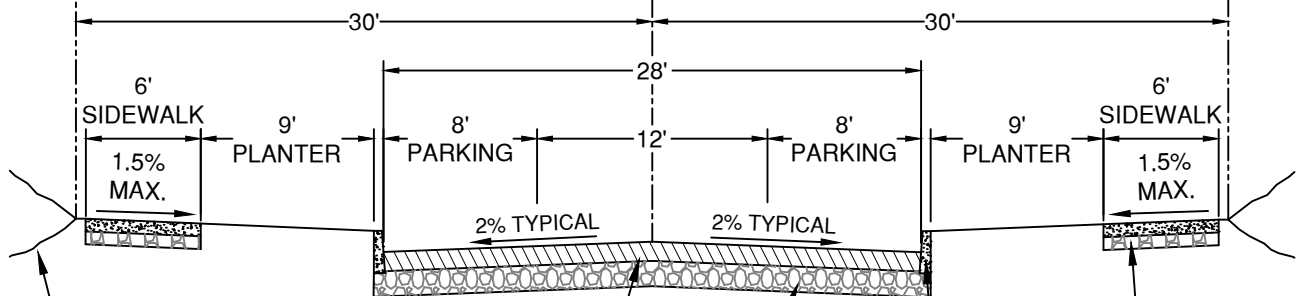

28' LOCAL ROAD - PARKING BOTH SIDES (SEE NOTE 3)

- "G" CUT/FILL SLOPE (SEE STD DWG R-1, NOTE 8)
- "E" ASPHALT BASE AND WEARING COURSES. THICKNESS PER CITY SPEC 00744/00745
- "F" AGGREGATE BASE PER CITY SPEC 00641
- "D" CITY STD CURB OR CURB & GUTTER - DWG R-3
- CITY SIDEWALK - BOTH SIDES (DWG R-4A)

PLTS:1      BLTS:1  
2 (STRIPED CENTERLINE)

LOCAL ROAD GENERAL NOTES:

1. SEE R-1 FOR GENERAL NOTES
2. UTILITY EASEMENTS MAY BE REQUIRED FOR PEDESTALS, TRANSFORMERS, ETC.
3. LOCAL ROADS WITH TRAVEL LANES LESS THAN 10' IN EACH DIRECTION ARE CONSIDERED QUEUING STREETS. SEE DESIGN STANDARDS SECTION 3.4.2.2 FOR APPROPRIATE QUEUING STREET APPLICATIONS.

DRAWN AJD	
DIV ROADWAY	
REV	DATE



**CITY OF BEND**  
STANDARD DRAWING  
710 NW WALL ST., BEND, OREGON 97701

**TYPICAL STREET CROSS-SECTION - LOCAL**

SCALE NTS
DATE 07/02/2025
APPR
STD DWG R-1D

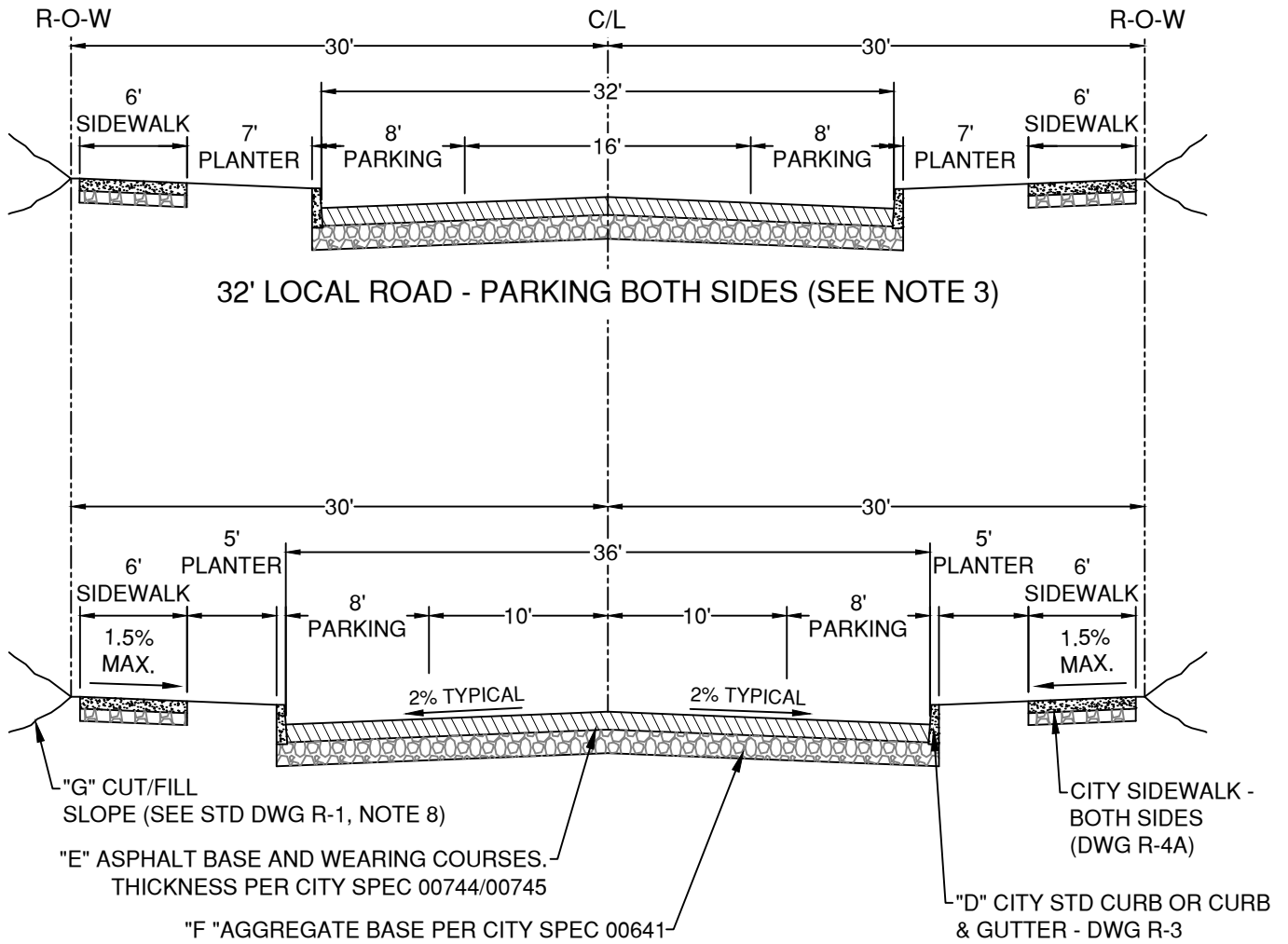

PLTS:1      BLTS:1  
 2 (STRIPED CENTERLINE)

LOCAL ROAD GENERAL NOTES:

1. SEE R-1 FOR GENERAL NOTES
2. UTILITY EASEMENTS MAY BE REQUIRED FOR PEDESTALS, TRANSFORMERS, ETC.
3. LOCAL ROADS WITH TRAVEL LANES LESS THAN 10' IN EACH DIRECTION ARE CONSIDERED QUEUING STREETS. SEE DESIGN STANDARDS SECTION 3.4.2.2 FOR APPROPRIATE QUEUING STREET APPLICATIONS.

DRAWN AJD	
DIV ROADWAY	
REV	DATE



**CITY OF BEND**  
 STANDARD DRAWING  
 710 NW WALL ST., BEND, OREGON 97701

**TYPICAL STREET CROSS-SECTION - LOCAL**

SCALE NTS
DATE 07/02/2025
APPR
STD DWG R-1E

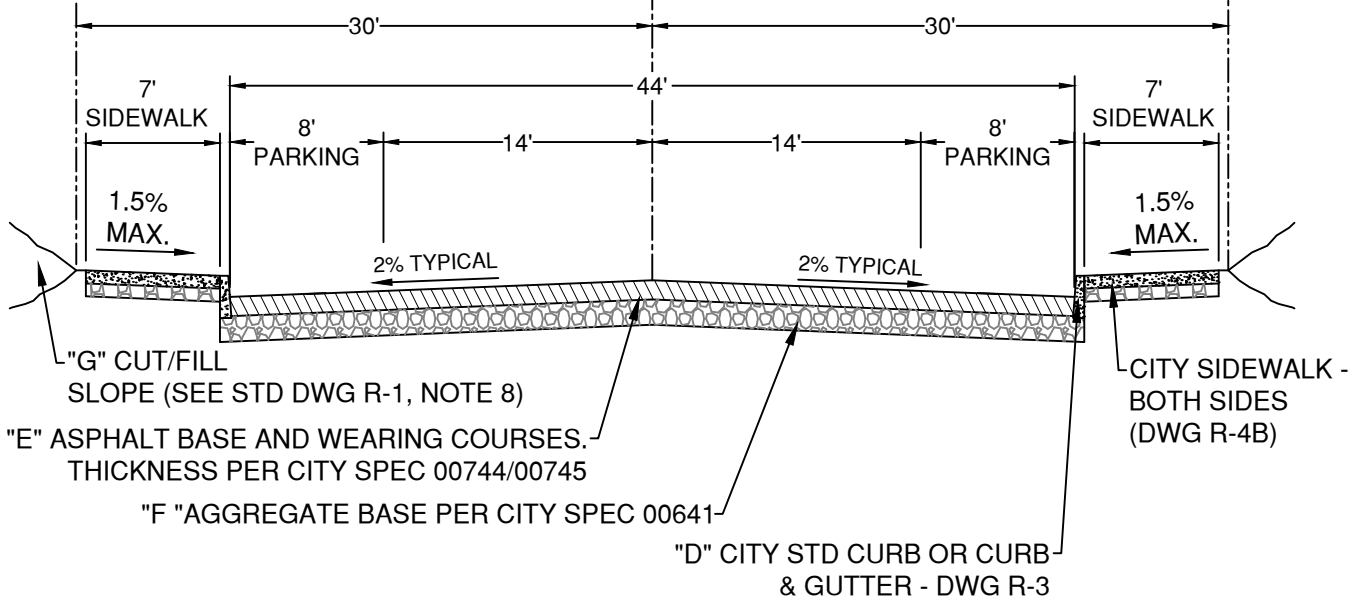
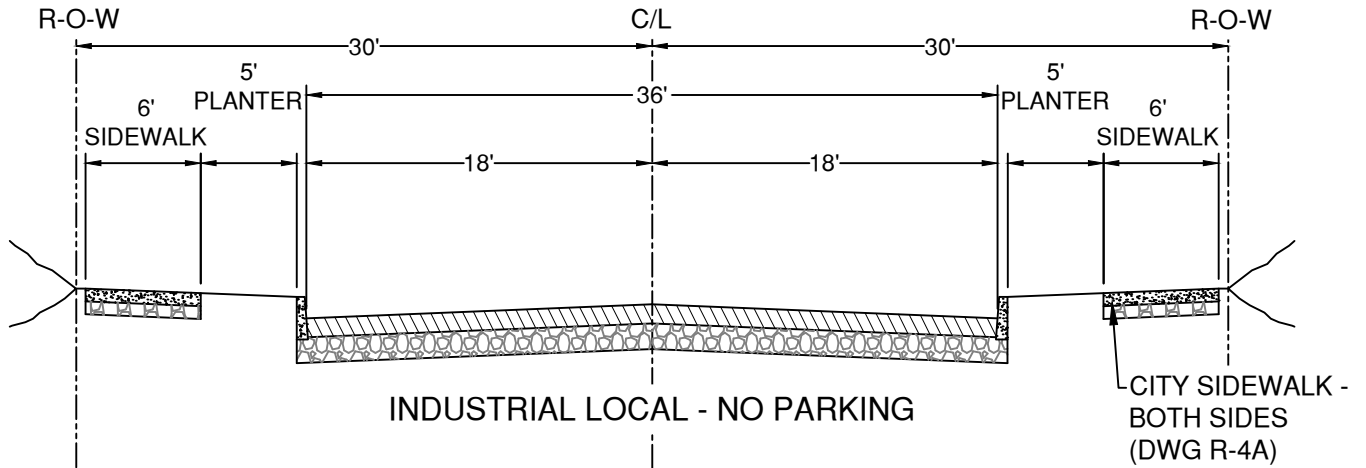

PLTS:1      BLTS:1  
 2 (STRIPED CENTERLINE)

LOCAL ROAD GENERAL NOTES:

1. SEE R-1 FOR GENERAL NOTES
2. THE SIDE PARKING IS ON MAY ALTERNATE BY BLOCK. PROVIDE PARKING NEXT TO PARKS, SCHOOLS, AND OTHER ACTIVITY GENERATING LAND USES.
3. UTILITY EASEMENTS MAY BE REQUIRED FOR PEDESTALS, TRANSFORMERS, ETC.
4. FOR PARKING ON ONE SIDE, COMBINE THE APPLICABLE HALF STREET SECTIONS FROM THE NO PARKING AND PARKING ON BOTH SIDES TYPICAL SECTIONS. THE ROAD CENTERLINE SHALL REMAIN IN THE CENTER OF ROW TO ALLOW FOR FUTURE EXPANSION.

DRAWN	AJD
DIV	ROADWAY
REV	DATE



CITY OF BEND

CITY OF BEND

STANDARD DRAWING

710 NW WALL ST., BEND, OREGON 97701

TYPICAL STREET CROSS-SECTION - INDUSTRIAL LOCAL

SCALE NTS

DATE 07/02/2025

APPR

STD DWG R-1F

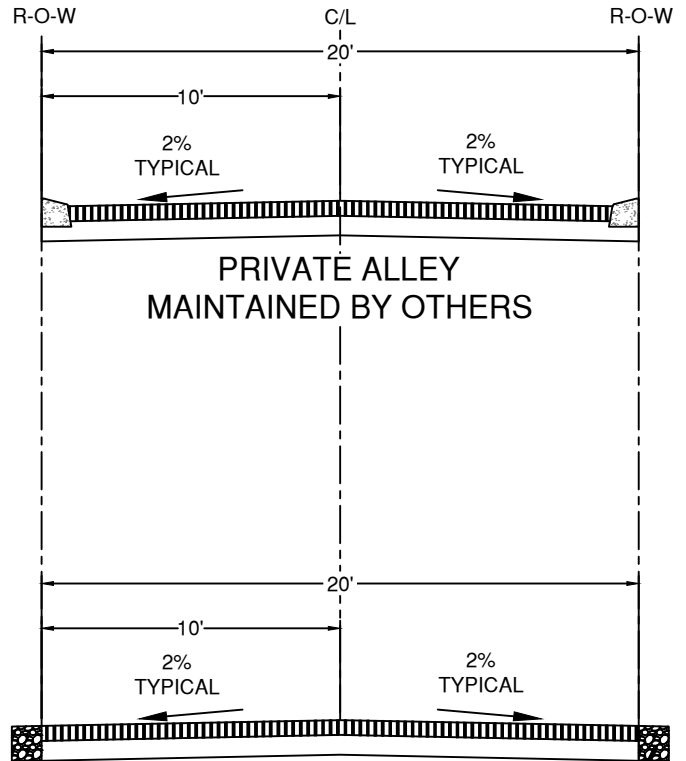
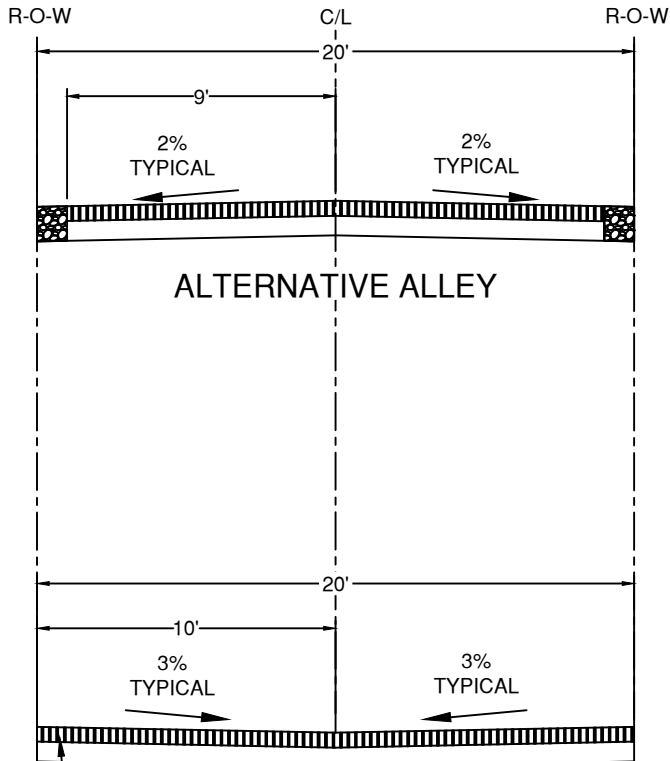

ALTERNATIVE ALLEY

PRIVATE ALLEY  
MAINTAINED BY OTHERS

ALTERNATIVE ALLEY

STANDARD ALLEY

ASPHALT BASE AND WEARING COURSES.  
THICKNESS PER "E" IN TABLE ON STD  
DWG R-1 AND PER CITY SPEC 00744

AGGREGATE BASE PER "F" IN  
TABLE ON STD DWG R-1 AND  
PER CITY SPEC 00640

ALLEY GENERAL NOTES:

1. SEE R-1 FOR GENERAL NOTES.
2. NEW ALLEY RIGHT-OF-WAY AND PAVED WIDTH WILL BE 20' WIDE. WHERE ALLEYS ARE INSTALLED IN EXISTING RIGHT-OF-WAY, THE PAVED WIDTH MAY BE UP TO 2 FEET LESS THAN THE RIGHT-OF-WAY WIDTH. 1-FOOT WIDE BUFFERS ON EACH SIDE OF THE ALLEY MAY BE LEFT UNPAVED WHEN ALLEYS ARE INSTALLED IN EXISTING RIGHT-OF-WAY.
3. SURFACE RESTORATION OF TRANSVERSE TRENCHING WILL NOT REQUIRE ASPHALT IF THE EXISTING ALLEY IS UNPAVED. RESTORE SURFACE TO MATCH EXISTING.

DRAWN	AJD
DIV	ROADWAY
REV	DATE



CITY OF BEND

CITY OF BEND

STANDARD DRAWING

710 NW WALL ST., BEND, OREGON 97701

TYPICAL STREET SECTION - ALLEY

SCALE NTS

DATE 01/31/2022

APPR

STD DWG R-1G

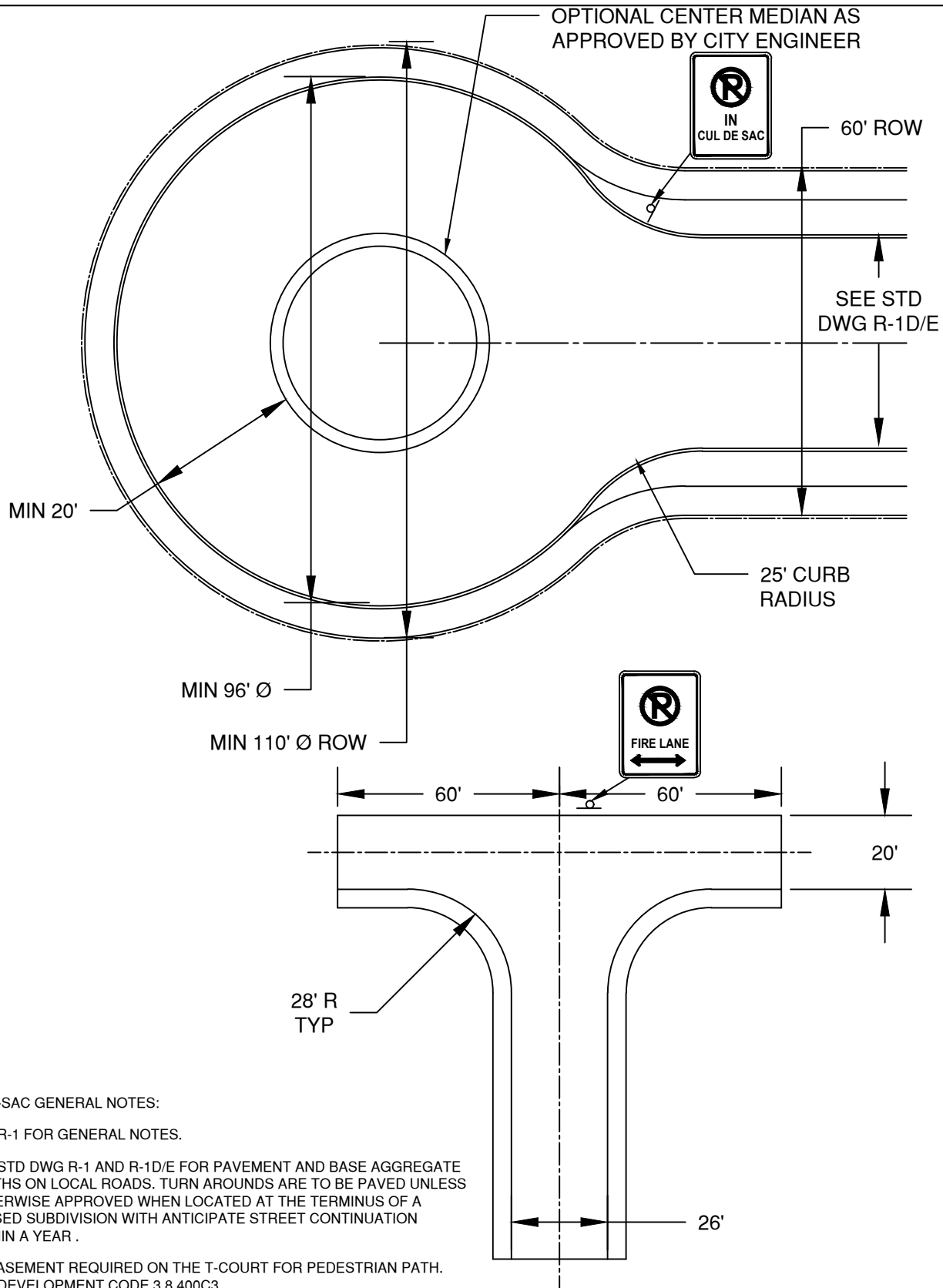

**CUL-DE-SAC GENERAL NOTES:**

1. SEE R-1 FOR GENERAL NOTES.
2. SEE STD DWG R-1 AND R-1D/E FOR PAVEMENT AND BASE AGGREGATE DEPTHS ON LOCAL ROADS. TURN AROUNDS ARE TO BE PAVED UNLESS OTHERWISE APPROVED WHEN LOCATED AT THE TERMINUS OF A PHASED SUBDIVISION WITH ANTICIPATE STREET CONTINUATION WITHIN A YEAR .
3. 10' EASEMENT REQUIRED ON THE T-COURT FOR PEDESTRIAN PATH. SEE DEVELOPMENT CODE 3.8.400C3
4. TURN AROUNDS TO BE IN COMPLIANCE WITH OREGON FIRE CODE.

DRAWN AJD	
DIV ROADWAY	
REV	DATE



**CITY OF BEND**

**CITY OF BEND**

STANDARD DRAWING

710 NW WALL ST., BEND, OREGON 97701

**TYPICAL STREET DEAD-END TURNAROUND**

SCALE NTS

DATE 11/01/2024

APPR

STD DWG R-1H

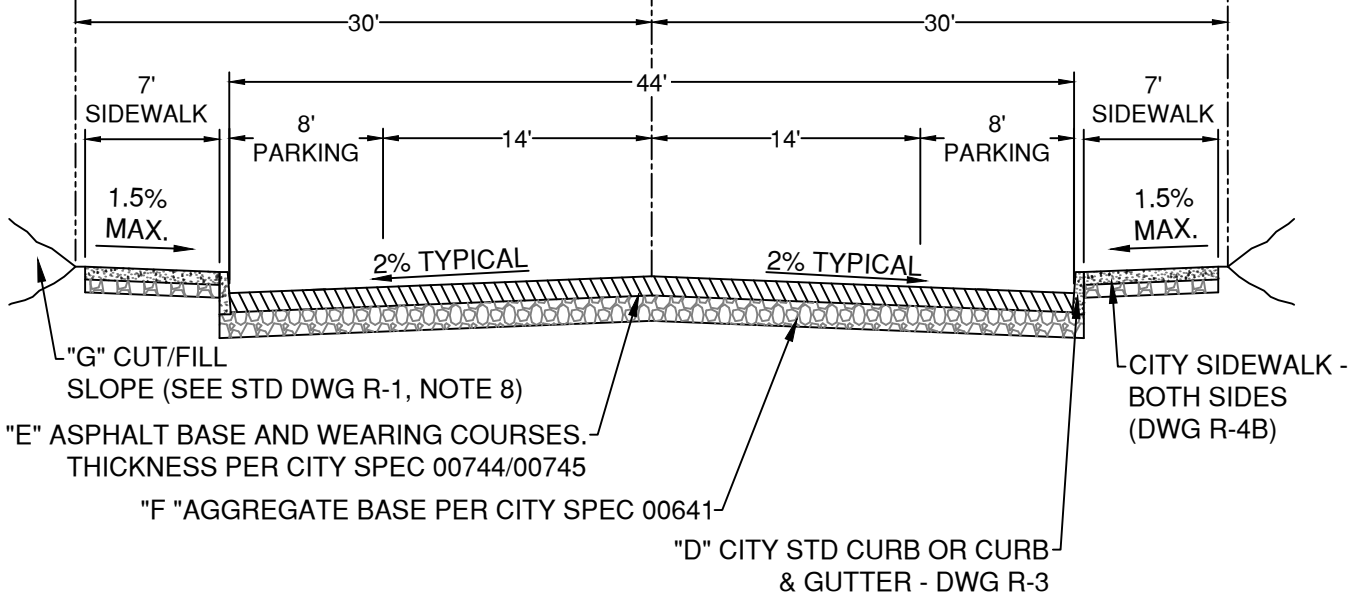
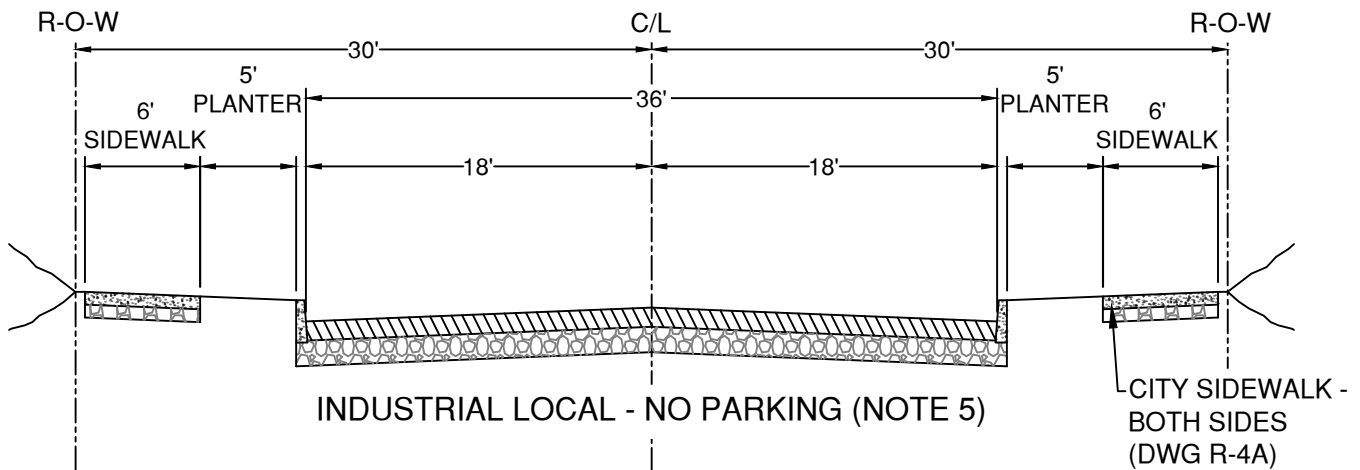

**INDUSTRIAL LOCAL - PARKING BOTH SIDES**

PLTS:1	BLTS:1
	2 (STRIPED CENTERLINE)

**LOCAL ROAD GENERAL NOTES:**

1. SEE R-1 FOR GENERAL NOTES
2. THE SIDE PARKING IS ON MAY ALTERNATE BY BLOCK. PROVIDE PARKING NEXT TO PARKS, SCHOOLS, AND OTHER ACTIVITY GENERATING LAND USES.
3. UTILITY EASEMENTS MAY BE REQUIRED FOR PEDESTALS, TRANSFORMERS, ETC.
4. FOR PARKING ON ONE SIDE, COMBINE THE APPLICABLE HALF STREET SECTIONS FROM THE NO PARKING AND PARKING ON BOTH SIDES TYPICAL SECTIONS. THE ROAD CENTERLINE SHALL REMAIN IN THE CENTER OF ROW TO ALLOW FOR FUTURE EXPANSION.
5. ON-SITE PARKING MAY BE PERMITTED WHEN PARKING IS RESTRICTED WITHIN 100 FEET OF INTERSECTIONS ON BLOCKS WHERE LAND USE / SITE DESIGN DOES NOT SERVE LARGER VEHICLES

<table border="1"> <tr> <td colspan="2">DRAWN AJD</td> </tr> <tr> <td colspan="2">DIV</td> </tr> <tr> <td>REV</td> <td>DATE</td> </tr> </table>	DRAWN AJD		DIV		REV	DATE	 <p><b>CITY OF BEND</b></p>	<p><b>CITY OF BEND</b></p> <p>STANDARD DRAWING</p> <p>710 NW WALL ST., BEND, OREGON 97701</p>	<p>SCALE NTS</p> <p>DATE 04/16/2026</p> <p>APPR</p> <p>STD DWG R-1F</p>
DRAWN AJD									
DIV									
REV	DATE								
<p><b>TYPICAL STREET CROSS-SECTION -INDUSTRIAL LOCAL</b></p>									

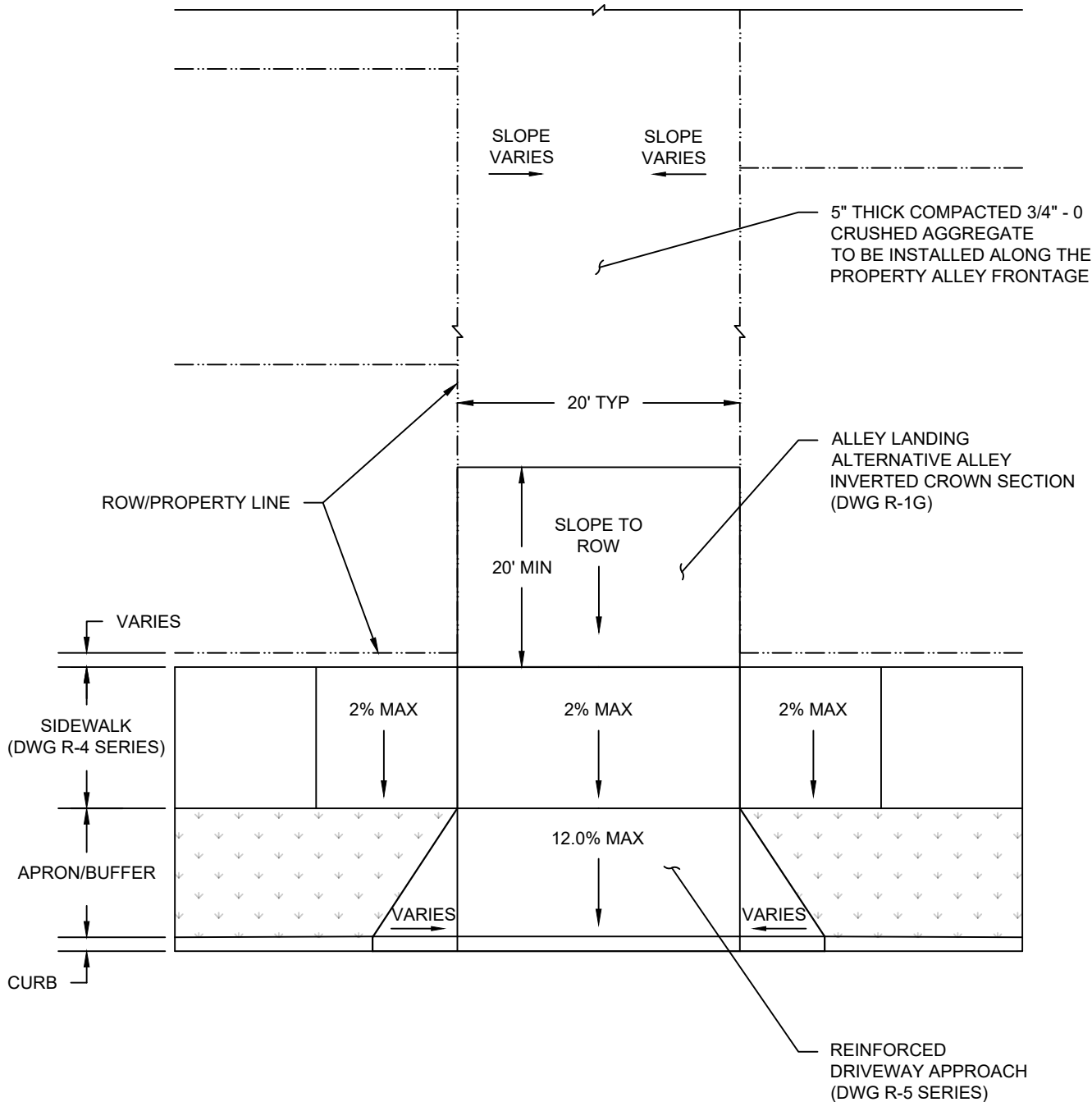

**GENERAL NOTES:**

1. IF THERE IS ALLEY ACCESS TO THE PROPERTY AND ONE OR MORE OF THE ALLEY DRIVEWAY APPROACHES ARE NOT IMPROVED TO CITY OF BEND STANDARDS AND SPECIFICATIONS, THEN AN ALLEY APPROACH MUST BE IMPROVED TO CITY OF BEND STANDARDS AND SPECIFICATIONS WITH THE PROPOSED DEVELOPMENT.
2. REFER TO THE BEND DEVELOPMENT CODE 4.2.400 FOR ADDITIONAL MINIMUM DEVELOPMENT STANDARDS REQUIREMENTS.

DRAWN	DSE
DIV	ROADWAY
REV	DATE



**CITY OF BEND**

**CITY OF BEND**

STANDARD DRAWING

710 NW WALL ST., BEND, OREGON 97701

**RESIDENTIAL ALLEY IMPROVEMENTS**

SCALE NTS

DATE 04/21/2023

APPR

STD DWG R-1J

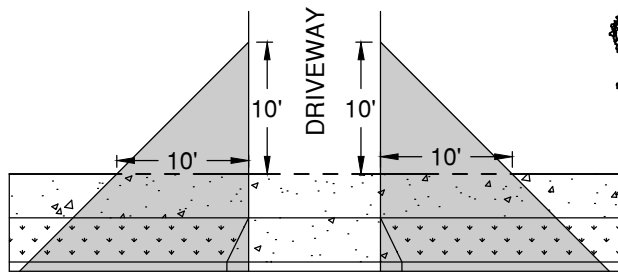

DRIVEWAY AND STREET INTERSECTION (SEE NOTE 5)

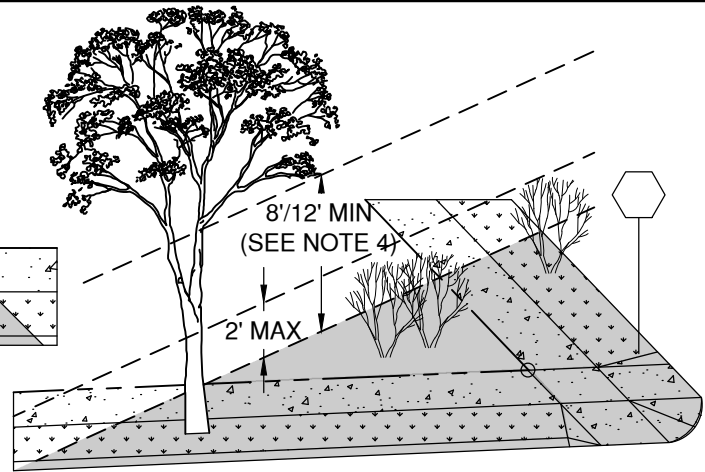

MAX HEIGHT OF SHRUBS AND MINIMUM LIMBING REQUIRED IN CLEAR VISION AREA

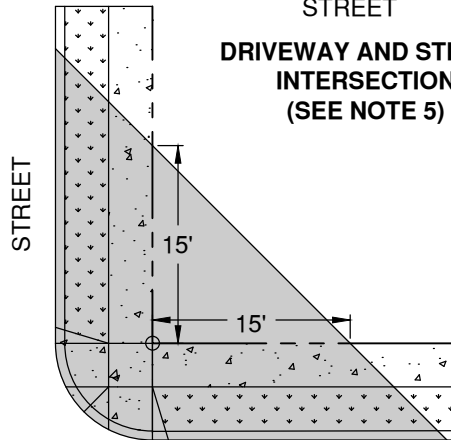

STREET/STREET INTERSECTION

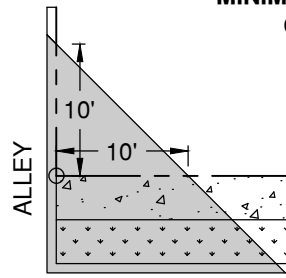

STREET/ALLEY INTERSECTION

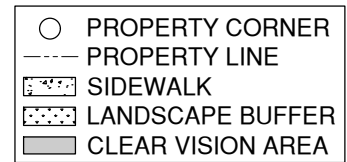

CLEAR VISION AREAS ARE ESTABLISHED AS FOLLOWS:

- 1) CLEAR VISION TRIANGLES SHALL BE ESTABLISHED AT THE CORNER OF ANY PROPERTY ADJACENT TO INTERSECTIONS OF PUBLIC OR PRIVATE STREETS, ALLEYS, MID-BLOCK LANES, AND/OR RAILROAD RIGHTS-OF-WAY.
- 2) THE TWO LEGS OF THE CLEAR VISION TRIANGLE ARE EACH MEASURED FROM THE POINT OF INTERSECTION OF THE TWO CORNER LOT LINES, SPECIAL SETBACK LINES, OR ACCESS EASEMENT LINES. WHERE LOT LINES HAVE ROUNDED CORNERS, THE LOT LINES ARE EXTENDED IN A STRAIGHT LINE TO A POINT OF INTERSECTION. THE CLEAR VISION AREA EXTENDS TO THE FACE OF CURB AT THE STREET OR ALLEY
- 3) THE LENGTH OF BOTH LEGS OF THE CLEAR VISION AREA TRIANGLE IS AS FOLLOWS:
  - TYPICAL, ALL ZONES: 15 FEET
  - RAILROADS: 15 FEET
  - ALLEY INTERSECTION: 10 FEET
  - DRIVEWAYS: 10 FEET
- 4) WITHIN THE CLEAR VISION AREA, OBSTRUCTIONS TO VISION OTHER THAN A STREET SIGN, HYDRANT, CROSSWALK CLOSED SIGNS, SIGN POST, OR POLE LESS THAN 8 INCHES IN DIAMETER SHALL BE CLEARED FROM PROPERTY UNDER THE CONTROL OF THE CITY, HOMEOWNER, OR DEVELOPER. SHRUBS OR FOLIAGE MUST NOT EXCEED 2'-0" IN HEIGHT. PLANTING NEW TREES OR INSTALLATION OF COMMUNICATION TOWERS AND TRANSFORMERS, ARE NOT PERMITTED WITHIN THE CLEAR VISION AREA. EXISTING TREES MUST BE MAINTAINED/LIMBED TO A MINIMUM OF 8'-0" ABOVE THE TOP OF CURB OR 12'-0" ABOVE ADJACENT BIKE LANES.
- 5) DRIVEWAY APPROACHES, ON-STREET PARKING AND DRIVEWAYS ARE NOT PERMITTED WITHIN THE CLEAR VISION AREA. ON-STREET PARKING DESIGN DOES NOT INCLUDE SPACES WITHIN 20 FEET OF AN ACCESSIBLE RAMP OR WITHIN 10 FEET OF A DRIVEWAY APPROACH.

NOTE: INTERSECTION SIGHT TRIANGLES ARE DISTINCT FROM, AND IN ADDITION TO, CLEAR VISION AREAS. INTERSECTION SIGHT TRIANGLE DIMENSIONS VARY WITH STREET WIDTH, GEOMETRY, TOPOGRAPHY, AND POSTED SPEED; ADDITIONAL CLEARING AS NECESSARY TO PROVIDE CLEAR INTERSECTION SIGHT DISTANCE IS ALSO REQUIRED; SEE CHAPTER 3.3 OF THE CITY OF BEND DESIGN STANDARDS.

DRAWN AJD	
DIV ROADWAY	
REV	DATE



CITY OF BEND

## CITY OF BEND

STANDARD DRAWING

710 NW WALL ST., BEND, OREGON 97701

# CLEAR VISION AREAS AT INTERSECTIONS

SCALE NTS

DATE 11/01/2024

APPR

STD DWG R-2

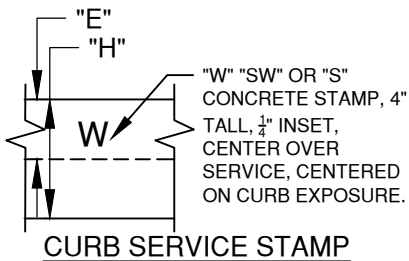
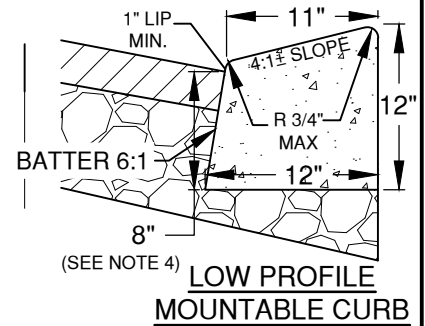
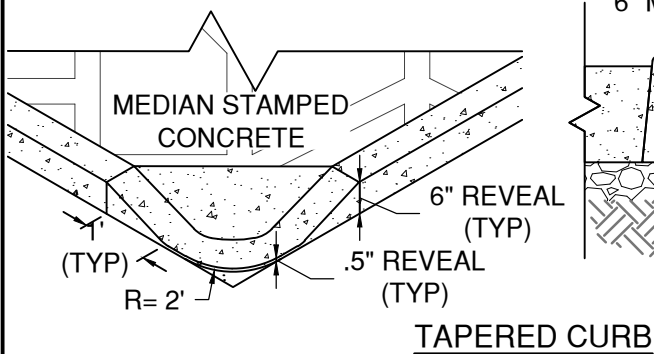
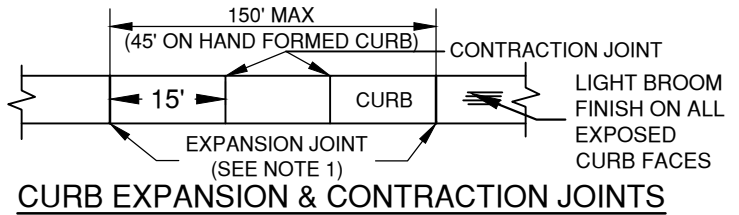
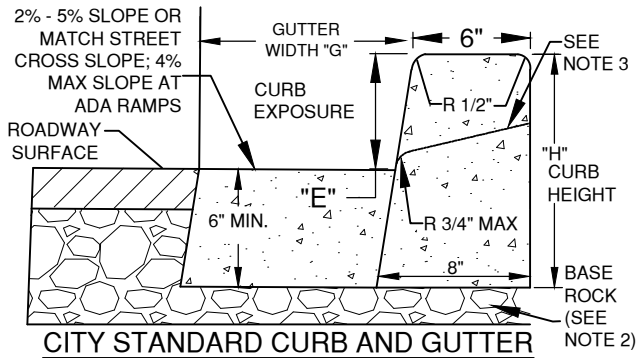
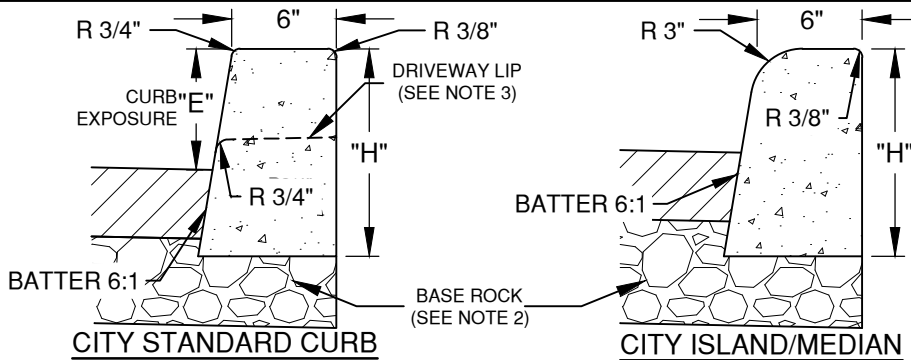

ROAD CLASS	CURB HEIGHT - H	CURB EXPOSURE - E	GUTTER WIDTH - G
ARTERIAL	16"	7"	12"
COLLECTOR	14"	6"	18"
LOCAL	12"	6"	18"

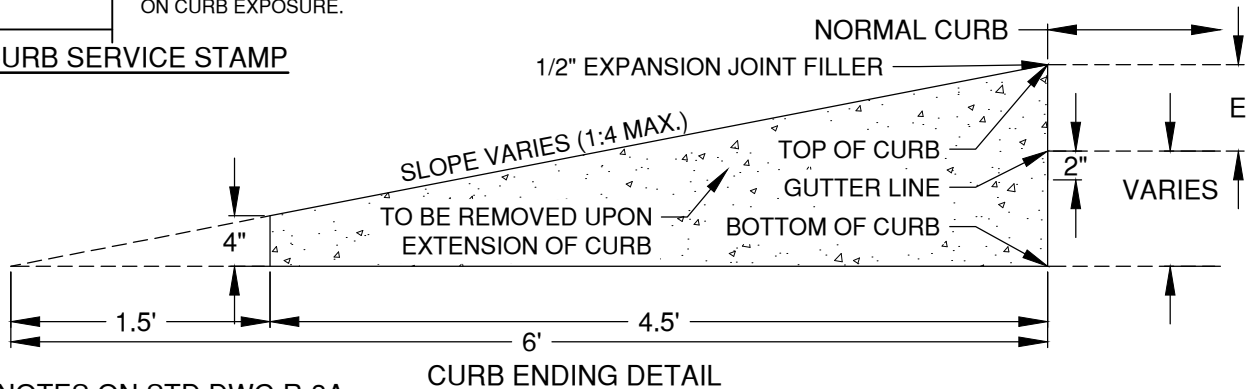

SEE NOTES ON STD DWG R-3A

DRAWN	AJD
DIV	ROADWAY
REV	DATE



CITY OF BEND

CITY OF BEND  
STANDARD DRAWING

710 NW WALL ST., BEND, OREGON 97701

CONCRETE CURB

SCALE NTS

DATE 03/22/2023

APPR

STD DWG R-3

NOTES FOR STD DWG R-3:

1. EXPANSION JOINTS REQUIRED AT END OF RADII, DRIVEWAY APRONS, POINTS OF CURVATURE, AND NO GREATER THAN 150' MAXIMUM.
2. AGGREGATE BASE SHALL CONFORM TO SPECIFICATION SECTION 00640/00641. DEPTH AS REQUIRED TO MATCH BOTTOM OF STREET SECTION, 4" MIN.
3. SLOPE DRIVEWAY TOWARD STREET. 3/4" MAXIMUM LIP AT GUTTER, 1" ON COLLECTORS AND ARTERIALS.
4. MOUNTABLE CURB PERMITTED ON LOCAL STREET CUL-DE-SACS, ALLEYS, AND WHERE PERMITTED BY THE CITY ENGINEER. WHERE SIDEWALK ABUTS CURB, SIDEWALK SHALL BE MIN. 6" THICK
5. CURB AND GUTTER MAY BE REQUIRED WHEN GUTTER SLOPE IS BETWEEN 0.5% - 0.75%.
6. CONCRETE MATERIAL AND PLACEMENT SHALL CONFORM TO SPECIFICATION SECTION 00759.
7. LOCATE TAPERED CURB ON DOWNSTREAM SIDE OF PEDESTRIAN REFUGE IN CENTER MEDIAN CURB RAMPS TO PROTECT FROM SNOW PLOW DAMAGE.
8. TACK COAT IS TO BE APPLIED TO CURB FACE PRIOR TO PAVING.

DRAWN AJD	
DIV ROADWAY	
REV	DATE



CITY OF BEND

CITY OF BEND

STANDARD DRAWING

710 NW WALL ST., BEND, OREGON 97701

CONCRETE CURB NOTES

SCALE NTS
DATE 03/22/2023
APPR
STD DWG R-3A

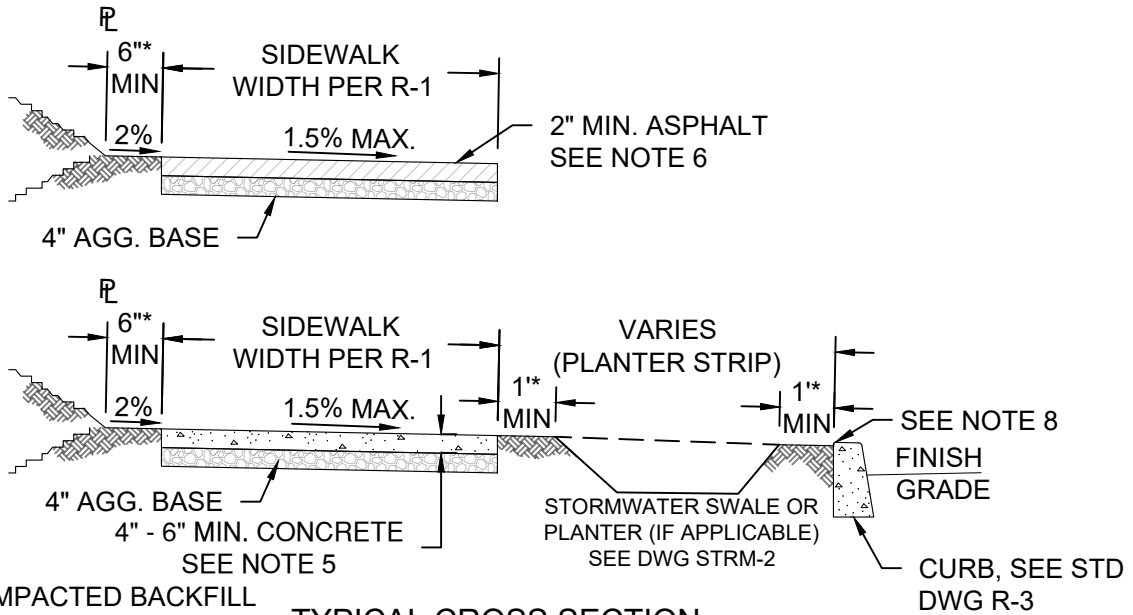

\*PROVIDE COMPACTED BACKFILL ADJACENT TO CURB AND SIDEWALK

TYPICAL CROSS SECTION

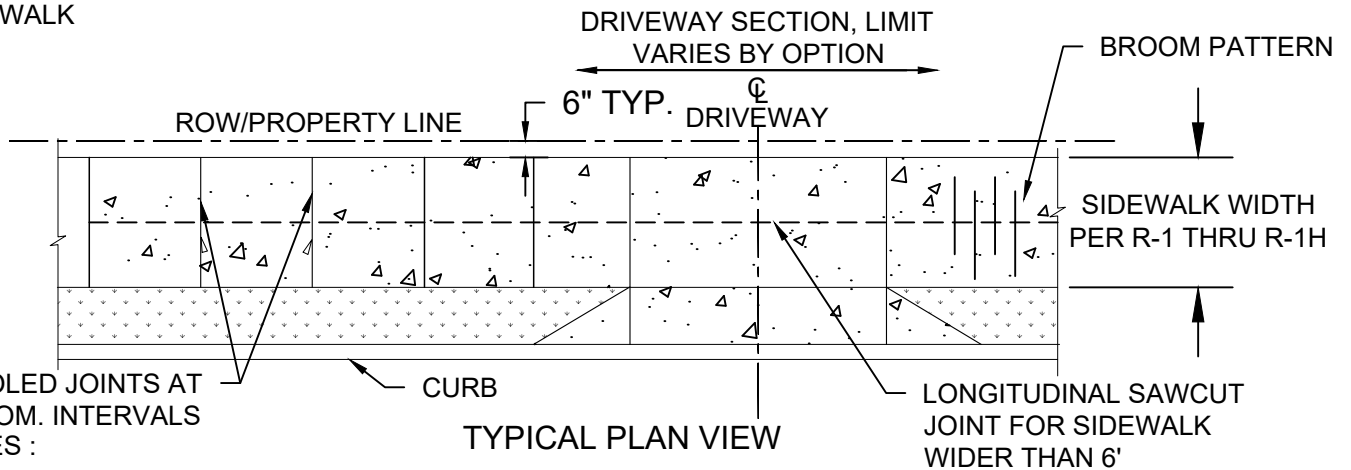

TYPICAL PLAN VIEW

NOTES :

1. SIDEWALKS SET BACK ADJACENT TO PROPERTY LINE ARE STANDARD. USE CURB-TIGHT SIDEWALKS ONLY WHERE PERMITTED. SIDEWALK SHALL BE PROPERTY-TIGHT EXCEPT TO MEANDER AROUND TREES OR BARRIERS (UTILITIES, SIGNS, ETC.) OR PER DESIGN STANDARD SECTION 3.4.7 - HILLSIDE.
2. CONST. EXPANSION JOINTS AT 25' MAXIMUM SPACING, AND AT POINTS OF TANGENCY, AND ON EACH SIDE OF DRIVEWAY APRONS. EXPANSION JOINTS MUST BE FULL DEPTH OF PAVING SECTION.
3. CONST. CONTRACTION JOINTS AT 5' MAXIMUM SPACING, AND AT ENDS OF EACH RAMP.
4. FOR DRIVEWAY DETAILS, SEE STD. DRGS. R-5A THROUGH R-5E.
5. SIDEWALK THICKNESS MINIMUM 4" THICK , TYPICAL. MINIMUM 6" THICK IF SIDEWALK IS INTENDED AS PORTION OF DRIVEWAY, CURB RAMP, OR ADJACENT TO MOUNTABLE CURB.
6. ASPHALT SHARED-USE PATH WHERE APPROVED BY THE ENGINEER.
7. SIDEWALK BASE WILL BE VISUALLY INSPECTED FOR COMPACTION. CITY INSPECTORS CAN REQUIRE COMPACTION TESTING WHERE BASE ROCK COMPACTION IS VISUALLY OUT OF COMPLIANCE WITH SPECIFICATIONS 00640 / 00641.
8. LANDSCAPING MUST BE 1/4 TO 1/2 INCH BELOW THE TOP OF ADJACENT SIDEWALK AND CURB.

DRAWN CJH DIV ROADWAY REV DATE		<b>CITY OF BEND</b> STANDARD DRAWING 710 NW WALL ST., BEND, OREGON 97701	SCALE NTS DATE 04/16/2026 APPR STD DWG R-4A
		<b>SHARED-USE PATH/SIDEWALK, SETBACK</b>	

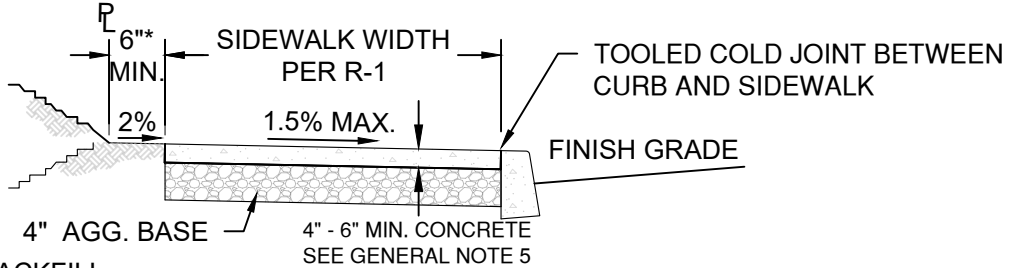
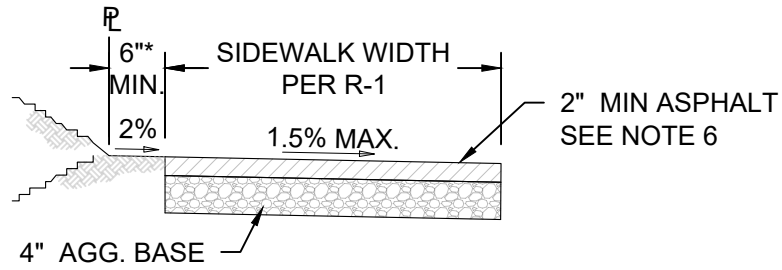

\*PROVIDE COMPACTED BACKFILL ADJACENT TO CURB AND SIDEWALK

TYPICAL CROSS SECTION

DRIVEWAY SECTION, LIMIT VARIES BY OPTION

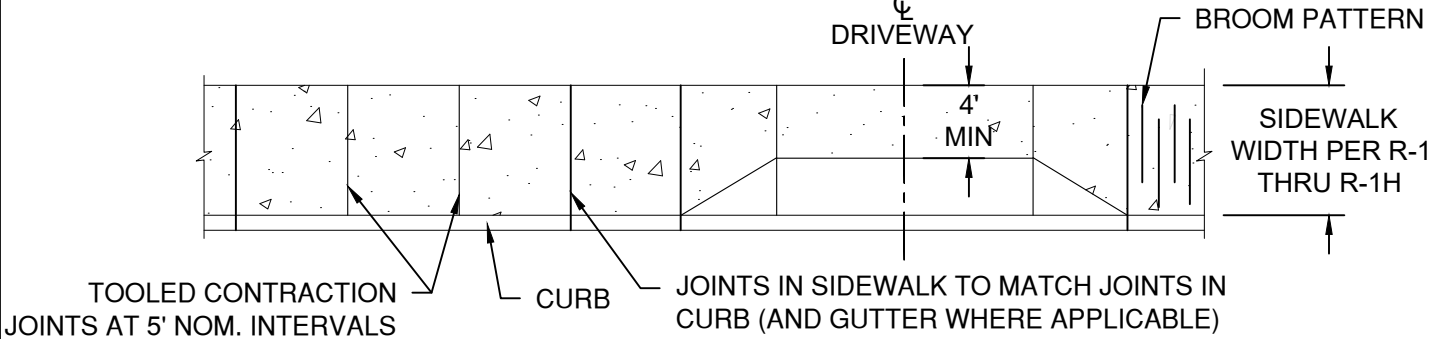

TYPICAL PLAN VIEW

NOTES:

1. SIDEWALKS SET BACK ADJACENT TO PROPERTY LINE ARE STANDARD. USE CURB-TIGHT SIDEWALKS ONLY WHERE PERMITTED.
2. CONST. EXPANSION JOINTS AT 25' MAXIMUM SPACING, AND AT POINTS OF TANGENCY, AND ON EACH SIDE OF DRIVEWAY APRONS. EXPANSION JOINTS MUST BE FULL DEPTH OF PAVING SECTION.
3. CONST. CONTRACTION JOINTS AT 5' MAXIMUM SPACING, AND AT ENDS OF EACH RAMP.
4. FOR DRIVEWAY DETAILS, SEE STD. DRGS. R-5A THROUGH R-5E.
5. SIDEWALK THICKNESS MINIMUM 4" THICK, TYPICAL. MINIMUM 6" THICK IF SIDEWALK IS PORTION OF DRIVEWAY, CURB RAMP, OR ADJACENT TO MOUNTABLE CURB.
6. ASPHALT SHARED-USE PATH WHERE APPROVED BY THE ENGINEER.
7. SIDEWALK BASE WILL BE VISUALLY INSPECTED FOR COMPACTION. CITY INSPECTOR CAN REQUIRE COMPACTION TESTING WHERE BASE ROCK COMPACTION IS VISUALLY OUT OF CONFORMANCE WITH SPECIFICATIONS 00640 / 00641.

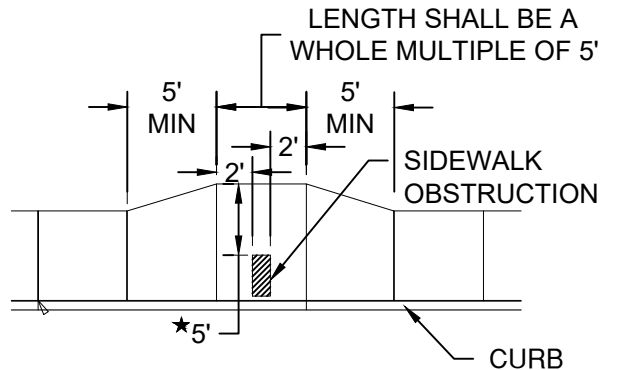

★ WHEN SITE CONSTRAINTS PROHIBIT A 5' PASSAGE, THE ENGINEER MAY DIRECT THIS TO BE REDUCED, BUT NO LESS THAN 4' REQUIRED SIDEWALK WIDENING AROUND OBSTRUCTIONS.

DRAWN AJD	
DIV ROADWAY	
REV	DATE
	ROADWAY



**CITY OF BEND**  
STANDARD DRAWING  
710 NW WALL ST., BEND, OREGON 97701

**SHARED-USE PATH/SIDEWALK, CURB-TIGHT**

SCALE NTS
DATE 04/16/2026
APPR
STD DWG R-4B

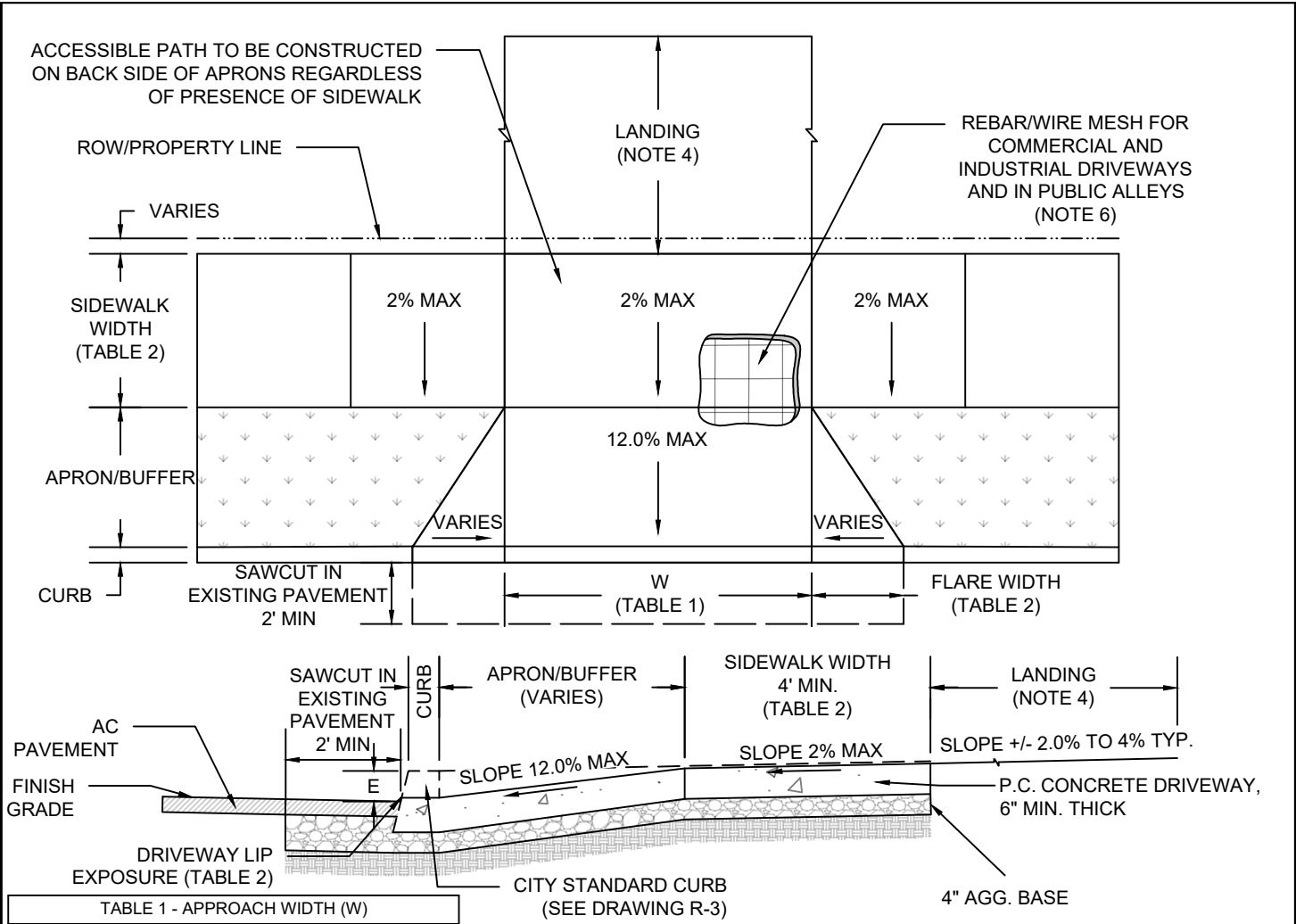

**TABLE 1 - APPROACH WIDTH (W)**

TYPE	WIDTH
RESIDENTIAL	10' - 24'
SINGLE FAMILY	10'-24'
TOWNHOME	32' MAX SHARED; 16' MAX LOCAL STREETS
DUPLEX	SUM 32' MAX (2 APRON MAX)
TRIPLEX	SUM 32' MAX (3 APRON MAX)
QUADPLEX	SUM 32' MAX (4 APRON MAX)
MULTIFAMILY	20' - 30'
COMMERCIAL	10' - 35'

**TYPICAL PLAN AND PROFILE VIEW  
DRIVEWAY APPROACH, SETBACK SIDEWALK (STANDARD)**

**TABLE 2 - DRIVEWAY APPROACH WITH SETBACK SIDEWALK SPECIFICATIONS**

TYPE OF STREET	SIDEWALK WIDTH	LIP EXPOSURE	APRON GRADE, POSITIVE GRADE TO ROW	FLARE WIDTH
LOCAL	PER R-1D THRU R-1F	3/4"	12.0% MAX	3'
COLLECTOR	PER R-1B & R-1-C	1"	12.0% MAX	6'
ARTERIAL	PER R-1A	1"	12.0% MAX	6'

- GENERAL NOTES:**
- SIDEWALKS SHALL MEET ALL STANDARDS OF CURRENT PUBLIC RIGHTS OF WAY ACCESSIBILITY GUIDELINES (PROWAG).
  - CURB AND SIDEWALK TYPES VARY, SEE PLANS. SEE STD. DRG. R-3 FOR CURB DETAILS. SEE STD. DRGS. R-4A & R-4B FOR SIDEWALK DETAILS.
  - TOOLED JOINTS ARE REQUIRED AT ALL DRIVEWAY SLOPE BREAK LINES.
  - THE LANDING SHALL BE PAVED WITH CONCRETE OR ASPHALT SURFACE FOR A MINIMUM OF 20 FEET ON ALLEYS. LANDINGS ON PRIVATE LOTS SHALL BE IN ACCORDANCE WITH THE BEND DEVELOPMENT CODE. CONSTRUCT AS DIRECTED OR AS SHOWN ON PLANS. DO NOT ENTER PRIVATE PROPERTY WITHOUT APPROPRIATE PERMIT OR EASEMENT. MATERIAL WITHIN THE ROW SHALL BE CONCRETE.
  - CHECK THE GUTTER FLOW DEPTH AT DRIVEWAY LOCATIONS TO ASSURE THAT THE DESIGN FLOOD DOES NOT OVERTOP THE BACK OF SIDEWALK AT DRIVEWAY. IF OVERTOPPING OCCURS PLACE AN INLET AT UPSTREAM SIDE OF DRIVEWAY OR PERFORM OTHER APPROVED DESIGN MITIGATION.
  - #4 REBAR (2'0" ON CENTER, TO BE SUSPENDED TO CENTER OF CONCRETE DEPTH) REQUIRED IN COMMERCIAL AND INDUSTRIAL DRIVEWAYS AND IN PUBLIC ALLEYS. 6"x6" 10 GAUGE MINIMUM WELDED WIRE MAY BE USED IN LIEU OF REBAR.
  - CONCRETE DRIVEWAY APRON REQUIRED WHERE SIDEWALK AND/OR CURB IS EXISTING/PROPOSED, OTHERWISE AN ASPHALT APPROACH CAN BE INSTALLED TO EDGE OF PAVEMENT TO SIMILAR WIDTHS OF THE DRIVEWAY APRON AS APPROVED BY THE CITY ENGINEER.
  - REFER TO THE BEND DEVELOPMENT CODE 3.1.400 AND 3.6.200 FOR NUMBER AND WIDTH OF APRONS PERMITTED PER LOT.
  - THIS SAME STANDARD APPLIES TO ALLEYS
  - NO PAVERS OR HEATED SIDEWALKS/APRONS ARE PERMITTED WITHIN THE RIGHT OF WAY.

DRAWN AJD		<p align="center"><b>CITY OF BEND</b></p> <p align="center">STANDARD DRAWING</p> <p align="center">710 NW WALL ST., BEND, OREGON 97701</p>	SCALE NTS
DIV ROADWAY			DATE 11/01/2024
REV DATE			APPR
<p align="center"><b>DRIVEWAY APPROACH, SETBACK (STANDARD)</b></p>			STD DWG R-5A

ACCESSIBLE PATH TO BE CONSTRUCTED ON BACK SIDE OF APRONS REGARDLESS OF PRESENCE OF SIDEWALK

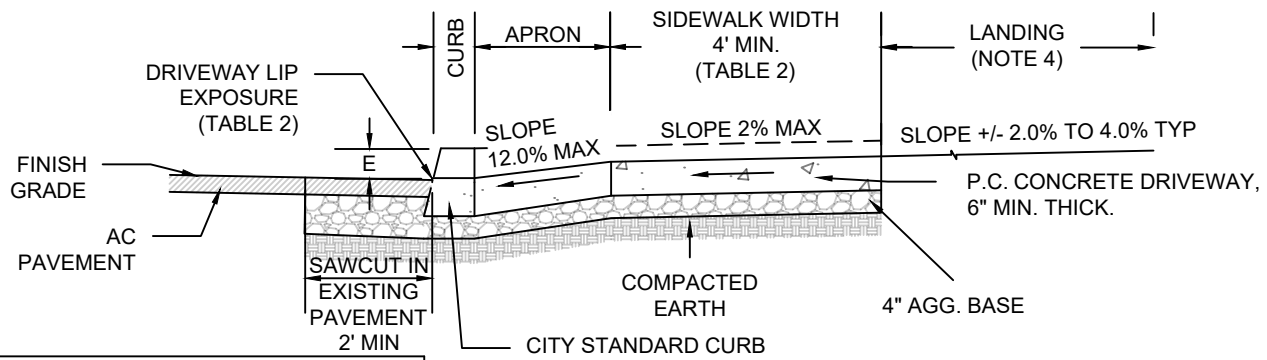
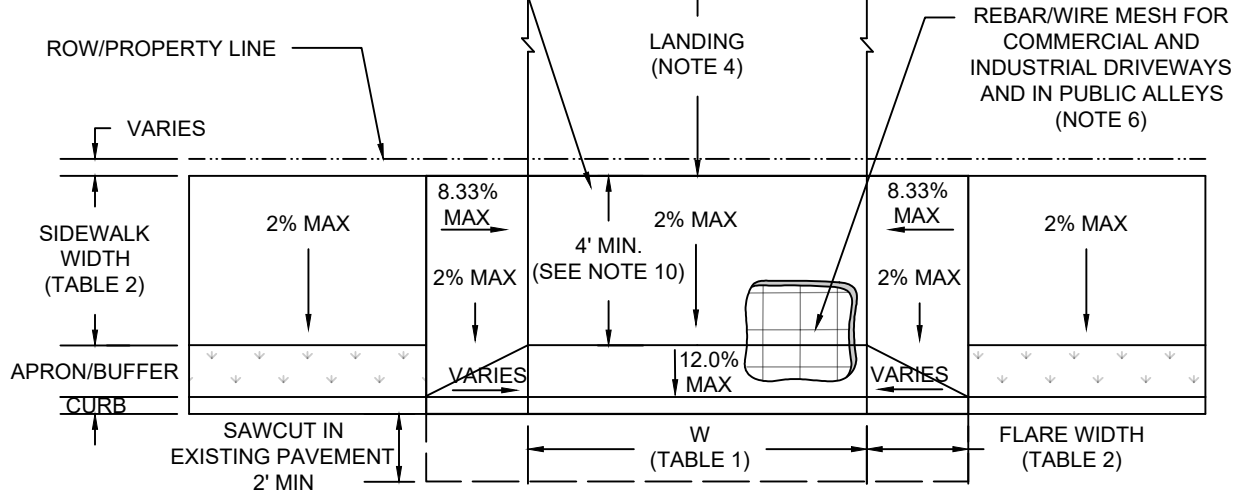

**TABLE 1 - APPROACH WIDTH (W)**

TYPE	WIDTH
RESIDENTIAL	10' - 24'
SINGLE FAMILY	10'-24'
TOWNHOME	32' MAX SHARED; 16' MAX LOCAL STREETS
DUPLEX	SUM 32' MAX (2 APRON MAX)
TRIPLEX	SUM 32' MAX (3 APRON MAX)
QUADPLEX	SUM 32' MAX (4 APRON MAX)
MULTIFAMILY	20' - 30'
COMMERCIAL	10' - 35'

**TYPICAL PLAN AND PROFILE VIEW  
DRIVEWAY APPROACH, SETBACK, PARTIALLY LOWERED  
(ALTERNATE B)**

**TABLE 2 - DRIVEWAY APPROACH WITH SETBACK SIDEWALK SPECIFICATIONS**

TYPE OF STREET	SIDEWALK WIDTH	LIP EXPOSURE	APRON GRADE, POSITIVE GRADE TO ROW	FLARE WIDTH
LOCAL	PER R-1D THRU R-1F	3/4"	12.0% MAX	3'
COLLECTOR	PER R-1B & R-1-C	1"	12.0% MAX	6'
ARTERIAL	PER R-1A	1"	12.0% MAX	6'

- GENERAL NOTES:**
- SIDEWALKS SHALL MEET ALL STANDARDS OF CURRENT PUBLIC RIGHTS OF WAY ACCESSIBILITY GUIDELINES (PROWAG).
  - CURB AND SIDEWALK TYPES VARY, SEE PLANS. SEE STD. DRG. R-3 FOR CURB DETAILS. SEE STD. DRGS. R-4A & R-4B FOR SIDEWALK DETAILS.
  - TOOLED JOINTS ARE REQUIRED AT ALL DRIVEWAY SLOPE BREAK LINES.
  - THE LANDING SHALL BE PAVED WITH CONCRETE OR ASPHALT SURFACE FOR A MINIMUM OF 20 FEET ON ALLEYS. LANDINGS ON PRIVATE LOTS SHALL BE IN ACCORDANCE WITH THE BEND DEVELOPMENT CODE. CONSTRUCT AS DIRECTED OR AS SHOWN ON PLANS. DO NOT ENTER PRIVATE PROPERTY WITHOUT APPROPRIATE PERMIT OR EASEMENT. MATERIAL WITHIN THE ROW SHALL BE CONCRETE.
  - CHECK THE GUTTER FLOW DEPTH AT DRIVEWAY LOCATIONS TO ASSURE THAT THE DESIGN FLOOD DOES NOT OVERTOP THE BACK OF SIDEWALK AT DRIVEWAY. IF OVERTOPPING OCCURS PLACE AN INLET AT UPSTREAM SIDE OF DRIVEWAY OR PERFORM OTHER APPROVED DESIGN MITIGATION.
  - #4 REBAR (2'0" ON CENTER, TO BE SUSPENDED TO CENTER OF CONCRETE DEPTH) REQUIRED IN COMMERCIAL AND INDUSTRIAL DRIVEWAYS AND IN PUBLIC ALLEYS. 6"x6" 10 GAUGE MINIMUM WELDED WIRE MAY BE USED IN LIEU OF REBAR.
  - CONCRETE DRIVEWAY APRON REQUIRED WHERE SIDEWALK AND/OR CURB IS EXISTING/PROPOSED, OTHERWISE AN ASPHALT APPROACH CAN BE INSTALLED TO EDGE OF PAVEMENT TO SIMILAR WIDTHS OF THE DRIVEWAY APRON AS APPROVED BY THE CITY ENGINEER.
  - REFER TO THE BEND DEVELOPMENT CODE 3.1.400 AND 3.6.200 FOR NUMBER AND WIDTH OF APRONS PERMITTED PER LOT.
  - THIS SAME STANDARD APPLIES TO ALLEYS
  - WHERE ON A LOW STRESS ROUTE, THE SIDEWALK/PATH WIDTH THROUGH THE DRIVEWAY APRON MUST BE MAINTAINED.
  - NO PAVERS OR HEATED SIDEWALKS/APRONS ARE PERMITTED WITHIN THE RIGHT OF WAY.

DRAWN	CJH
DIV	ROADWAY
REV	DATE



**CITY OF BEND**  
STANDARD DRAWING  
710 NW WALL ST., BEND, OREGON 97701

**DRIVEWAY APPROACH, SETBACK, PARTIALLY LOWERED (ALTERNATE B)**

SCALE	NTS
DATE	11/01/2024
APPR	
STD DWG	R-5B

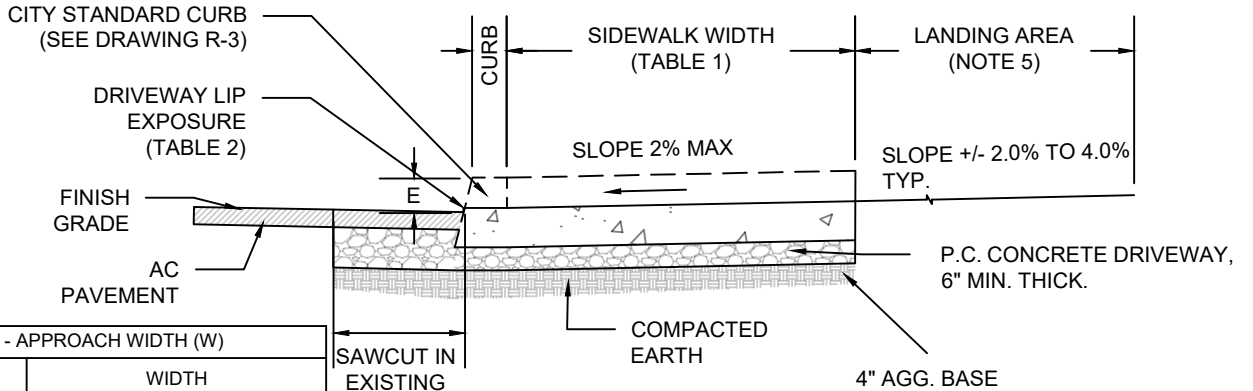
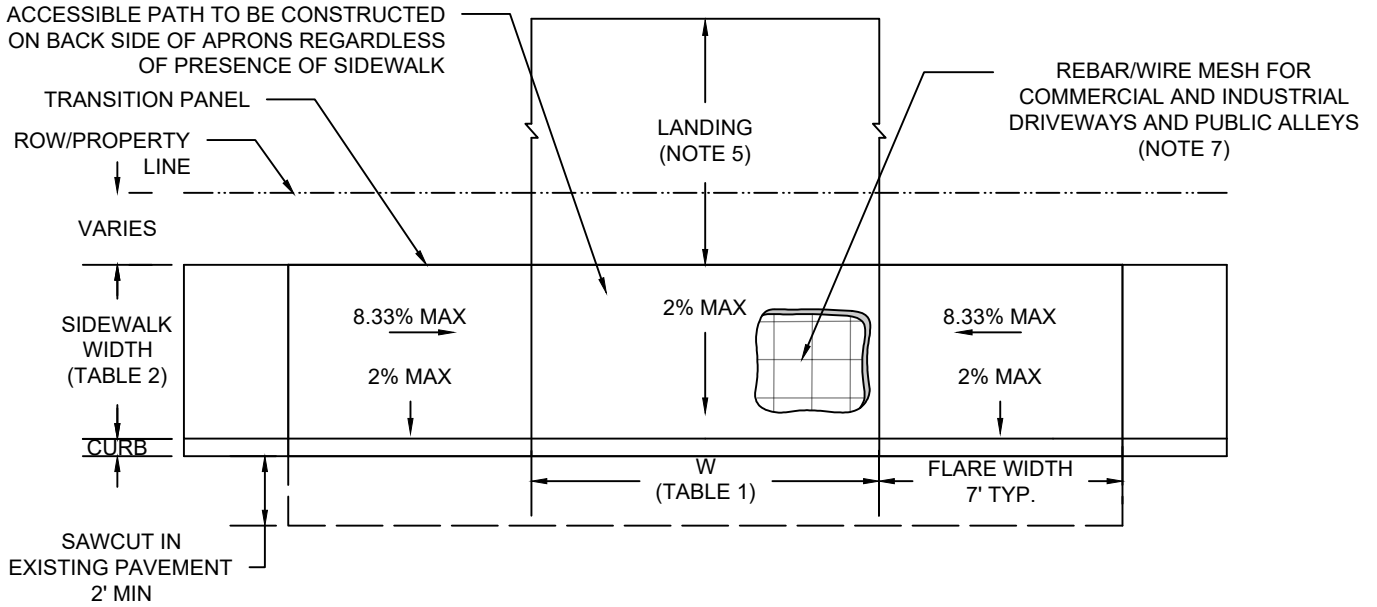

TYPE	WIDTH
RESIDENTIAL	10' - 24'
SINGLE FAMILY	10'-24'
TOWNHOME	32' MAX SHARED; 16' MAX LOCAL STREETS
DUPLEX	SUM 32' MAX (2 APRON MAX)
TRIPLEX	SUM 32' MAX (3 APRON MAX)
QUADPLEX	SUM 32' MAX (4 APRON MAX)
MULTIFAMILY	20' - 30'
COMMERCIAL	10' - 35'

**TYPICAL PLAN AND PROFILE VIEW DRIVEWAY APPROACH, CURB-TIGHT, FULLY LOWERED (ALTERNATE C)**

TYPE OF STREET	SIDEWALK WIDTH	LIP EXPOSURE	APRON GRADE, POSITIVE GRADE TO ROW	FLARE WIDTH
LOCAL	PER R-1D THRU R-1F	¾"	12.0% MAX	3'
COLLECTOR	PER R-1B & R1-C	1"	12.0% MAX	6'
ARTERIAL	PER R-1A	1"	12.0% MAX	6'

- GENERAL NOTES:**
- SIDEWALKS SHALL MEET ALL STANDARDS OF CURRENT PUBLIC RIGHTS OF WAY ACCESSIBILITY GUIDELINES (PROWAG).
  - CURB AND SIDEWALK TYPES VARY, SEE PLANS. SEE STD. DRG. R-3 FOR CURB DETAILS. SEE STD. DRGS. R-4A & R-4B FOR SIDEWALK DETAILS.
  - TOOLED JOINTS ARE REQUIRED AT ALL DRIVEWAY SLOPE BREAK LINES.
  - THE LANDING SHALL BE PAVED WITH CONCRETE OR ASPHALT SURFACE FOR A MINIMUM OF 20 FEET ON ALLEYS. LANDINGS ON PRIVATE LOTS SHALL BE IN ACCORDANCE WITH THE BEND DEVELOPMENT CODE. CONSTRUCT AS DIRECTED OR AS SHOWN ON PLANS. DO NOT ENTER PRIVATE PROPERTY WITHOUT APPROPRIATE PERMIT OR EASEMENT. MATERIAL WITHIN THE ROW SHALL BE CONCRETE.
  - CHECK THE GUTTER FLOW DEPTH AT DRIVEWAY LOCATIONS TO ASSURE THAT THE DESIGN FLOOD DOES NOT OVERTOP THE BACK OF SIDEWALK AT DRIVEWAY. IF OVERTOPPING OCCURS PLACE AN INLET AT UPSTREAM SIDE OF DRIVEWAY OR PERFORM OTHER APPROVED DESIGN MITIGATION.
  - #4 REBAR (20" ON CENTER, TO BE SUSPENDED TO CENTER OF CONCRETE DEPTH) REQUIRED IN COMMERCIAL AND INDUSTRIAL DRIVEWAYS AND IN PUBLIC ALLEYS. 6"x6" 10 GAUGE MINIMUM WELDED WIRE MAY BE USED IN LIEU OF REBAR.
  - CONCRETE DRIVEWAY APRON REQUIRED WHERE SIDEWALK AND/OR CURB IS EXISTING/PROPOSED, OTHERWISE AN ASPHALT APPROACH CAN BE INSTALLED TO EDGE OF PAVEMENT TO SIMILAR WIDTHS OF THE DRIVEWAY APRON AS APPROVED BY THE CITY ENGINEER.
  - REFER TO THE BEND DEVELOPMENT CODE 3.1.400 AND 3.6.200 FOR NUMBER AND WIDTH OF APRONS PERMITTED PER LOT.
  - THIS SAME STANDARD APPLIES TO ALLEYS
  - NO PAVERS OR HEATED SIDEWALKS/APRONS ARE PERMITTED WITHIN THE RIGHT OF WAY.

DRAWN A.JD DIV ROADWAY REV DATE		<b>CITY OF BEND</b> STANDARD DRAWING 710 NW WALL ST., BEND, OREGON 97701	SCALE NTS
<b>CITY OF BEND</b>			DATE 11/01/2024
DRIVEWAY APPROACH, CURB-TIGHT, FULLY LOWERED (ALTERNATE C)			APPR
			STD DWG R-5C

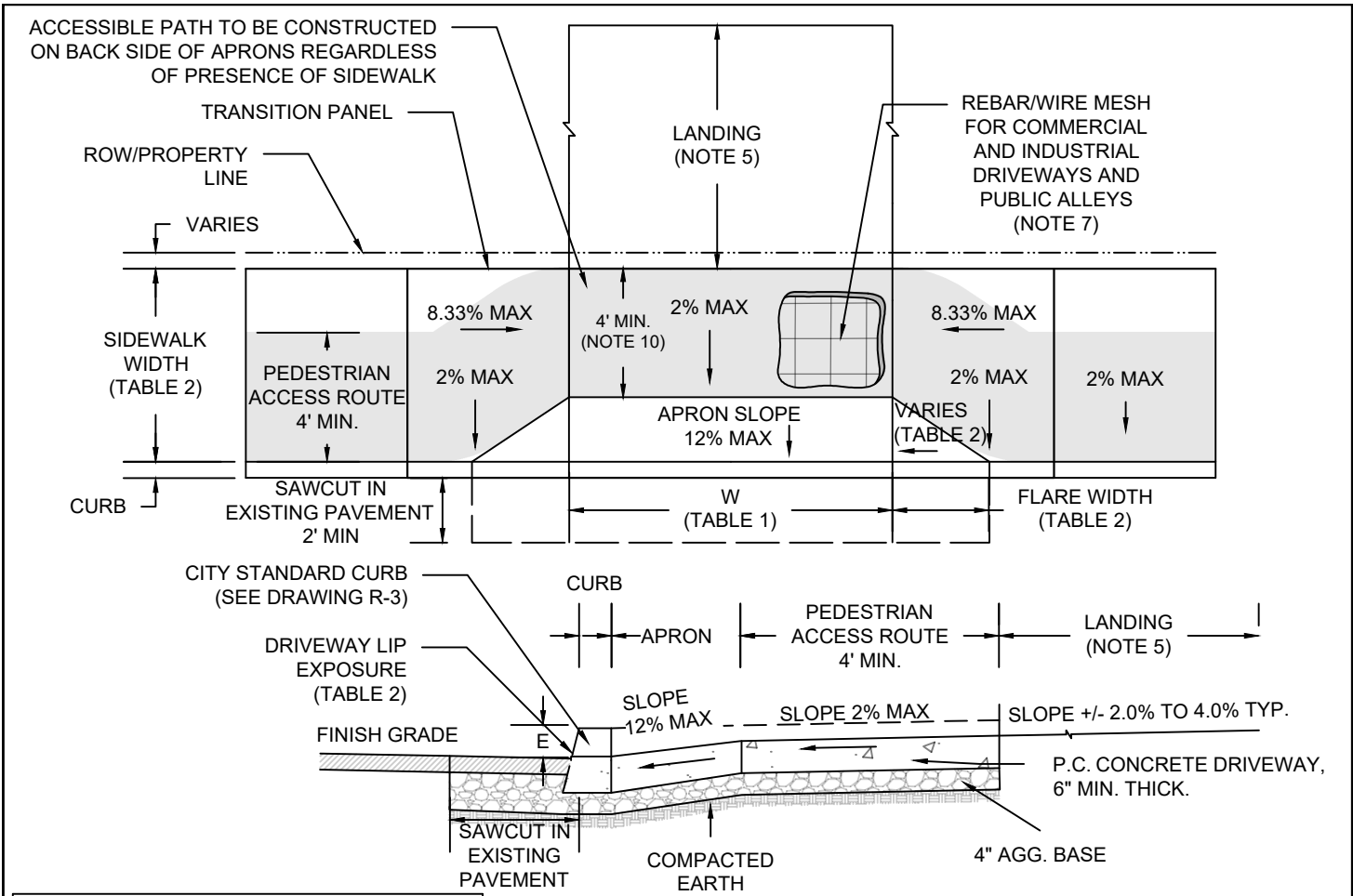

**TABLE 1 - APPROACH WIDTH (W)**

TYPE	WIDTH
RESIDENTIAL	10' - 24'
SINGLE FAMILY	10'-24'
TOWNHOME	32' MAX SHARED; 16' MAX LOCAL STREETS
DUPLEX	SUM 32' MAX (2 APRON MAX)
TRIPLEX	SUM 32' MAX (3 APRON MAX)
QUADPLEX	SUM 32' MAX (4 APRON MAX)
MULTIFAMILY	20' - 30'
COMMERCIAL	10' - 35'

**TYPICAL PLAN AND PROFILE VIEW  
DRIVEWAY APPROACH, CURB-TIGHT, PARTIALLY LOWERED (ALTERNATE D)**

**TABLE 2 - DRIVEWAY APPROACH WITH SETBACK SIDEWALK SPECIFICATIONS**

TYPE OF STREET	SIDEWALK WIDTH	LIP EXPOSURE	APRON GRADE, POSITIVE GRADE TO ROW	FLARE WIDTH
LOCAL	PER R-1D THRU R-1F	3/4"	12.0% MAX	3'
COLLECTOR	PER R-1B & R-1C	1"	12.0% MAX	6'
ARTERIAL	PER R-1A	1"	12.0% MAX	6'

- GENERAL NOTES:**
- SIDEWALKS SHALL MEET ALL STANDARDS OF CURRENT PUBLIC RIGHTS OF WAY ACCESSIBILITY GUIDELINES (PROWAG).
  - CURB AND SIDEWALK TYPES VARY, SEE PLANS. SEE STD. DRG. R-3 FOR CURB DETAILS. SEE STD. DRGS. R-4A & R-4B FOR SIDEWALK DETAILS.
  - TOOLED JOINTS ARE REQUIRED AT ALL DRIVEWAY SLOPE BREAK LINES.
  - THE LANDING SHALL BE PAVED WITH CONCRETE OR ASPHALT SURFACE FOR A MINIMUM OF 20 FEET ON ALLEYS. LANDINGS ON PRIVATE LOTS SHALL BE IN ACCORDANCE WITH THE BEND DEVELOPMENT CODE. CONSTRUCT AS DIRECTED OR AS SHOWN ON PLANS. DO NOT ENTER PRIVATE PROPERTY WITHOUT APPROPRIATE PERMIT OR EASEMENT. MATERIAL WITHIN THE ROW SHALL BE CONCRETE.
  - CHECK THE GUTTER FLOW DEPTH AT DRIVEWAY LOCATIONS TO ASSURE THAT THE DESIGN FLOOD DOES NOT OVERTOP THE BACK OF SIDEWALK AT DRIVEWAY. IF OVERTOPPING OCCURS PLACE AN INLET AT UPSTREAM SIDE OF DRIVEWAY OR PERFORM OTHER APPROVED DESIGN MITIGATION.
  - #4 REBAR (2"0" ON CENTER, TO BE SUSPENDED TO CENTER OF CONCRETE DEPTH) REQUIRED IN COMMERCIAL AND INDUSTRIAL DRIVEWAYS AND IN PUBLIC ALLEYS. 6"x6" 10 GAUGE MINIMUM WELDED WIRE MAY BE USED IN LIEU OF REBAR.
  - CONCRETE DRIVEWAY APRON REQUIRED WHERE SIDEWALK AND/OR CURB IS EXISTING/PROPOSED, OTHERWISE AN ASPHALT APPROACH CAN BE INSTALLED TO EDGE OF PAVEMENT TO SIMILAR WIDTHS OF THE DRIVEWAY APRON AS APPROVED BY THE CITY ENGINEER.
  - REFER TO THE BEND DEVELOPMENT CODE 3.1.400 AND 3.6.200 FOR NUMBER AND WIDTH OF APRONS PERMITTED PER LOT.
  - THIS SAME STANDARD APPLIES TO ALLEYS
  - WHERE ON A LOW STRESS ROUTE, THE SIDEWALK/PATH WIDTH THROUGH THE DRIVEWAY APRON MUST BE MAINTAINED.
  - NO PAVERS OR HEATED SIDEWALKS/APRONS ARE PERMITTED WITHIN THE RIGHT OF WAY.

DRAWN A.JD		<p align="center"><b>CITY OF BEND</b> STANDARD DRAWING 710 NW WALL ST., BEND, OREGON 97701</p>	SCALE NTS
DIV ROADWAY			DATE 11/01/2024
REV DATE			APPR
<p align="center"><b>CITY OF BEND</b></p>		DRIVEWAY APPROACH, CURB-TIGHT, PARTIALLY LOWERED (ALTERNATE D)	STD DWG R-5D

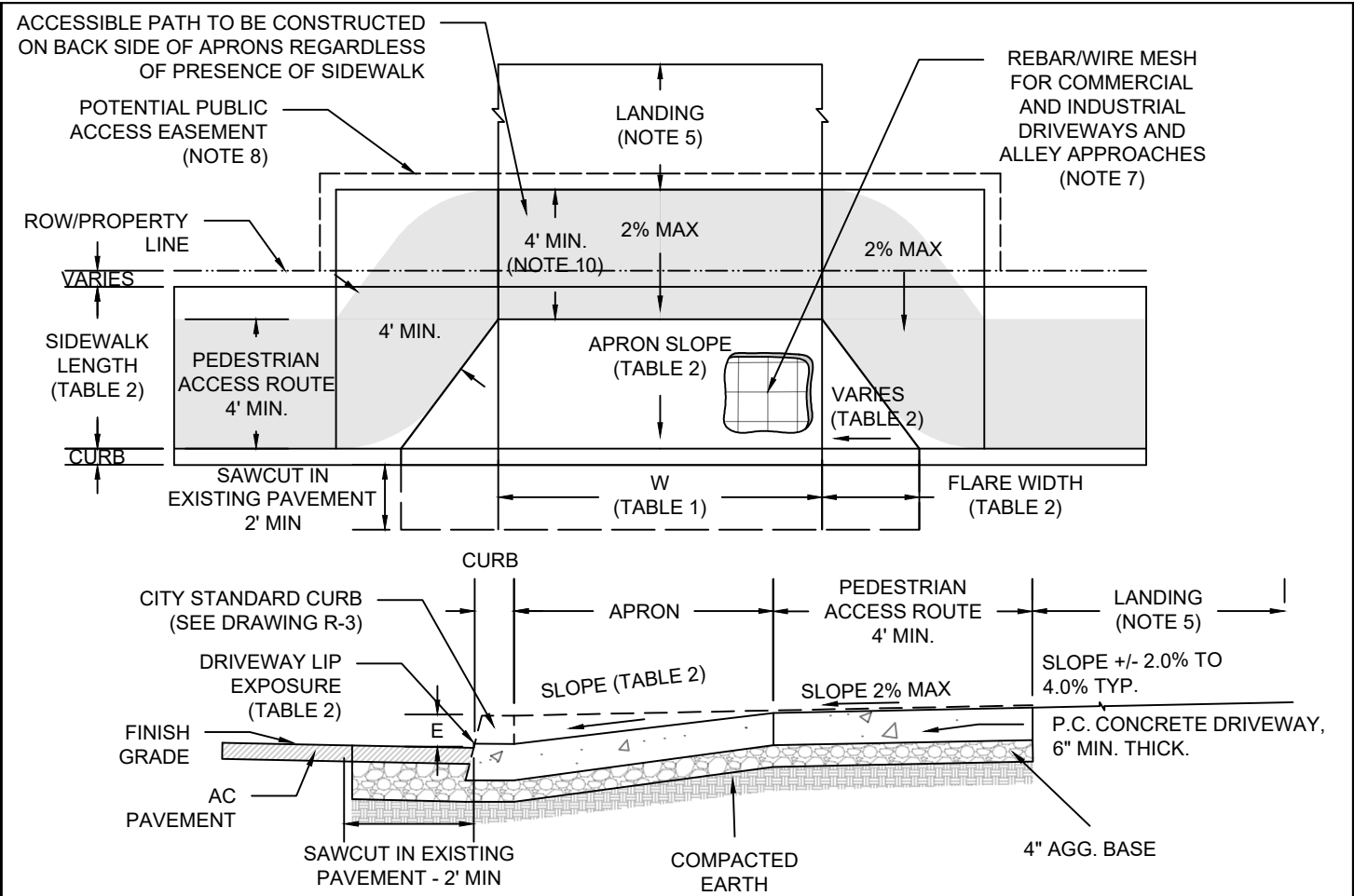

**TABLE 1 - APPROACH WIDTH (W)**

TYPE	WIDTH
RESIDENTIAL	10' - 24'
SINGLE FAMILY	10'-24'
TOWNHOME	32' MAX SHARED; 16' MAX LOCAL STREETS
DUPLEX	SUM 32' MAX (2 APRON MAX)
TRIPLEX	SUM 32' MAX (3 APRON MAX)
QUADPLEX	SUM 32' MAX (4 APRON MAX)
MULTIFAMILY	20' - 30'
COMMERCIAL	10' - 35'

**TYPICAL PLAN VIEW  
DRIVEWAY APPROACH, CURB-TIGHT, WRAPPING SIDEWALK  
(ALTERNATE E)**

**TABLE 2 - DRIVEWAY APPROACH SPECIFICATIONS WITH CURB-TIGHT WRAPPING SIDEWALK**

TYPE OF STREET	MINIMUM SIDEWALK WIDTH	LIP EXPOSURE	APRON GRADE, POSITIVE GRADE TO ROW	FLARE WIDTH
LOCAL	PER R-1D THRU R-1F	3/4"	12.0% MAX	3'
COLLECTOR	PER R-1B & R-1C	1"	12.5% MAX	6'
ARTERIAL	PER R-1A	1"	12.5% MAX	6'

- GENERAL NOTES:**
- SIDEWALKS SHALL MEET ALL STANDARDS OF CURRENT PUBLIC RIGHTS OF WAY ACCESSIBILITY GUIDELINES (PROWAG).
  - CURB AND SIDEWALK TYPES VARY, SEE PLANS. SEE STD. DRG. R-3 FOR CURB DETAILS. SEE STD. DRGS. R-4A & R-4B FOR SIDEWALK DETAILS.
  - TOOLED JOINTS ARE REQUIRED AT ALL DRIVEWAY SLOPE BREAK LINES.
  - THE LANDING SHALL BE PAVED WITH CONCRETE OR ASPHALT SURFACE FOR A MINIMUM OF 20 FEET ON ALLEYS. LANDINGS ON PRIVATE LOTS SHALL BE IN ACCORDANCE WITH THE BEND DEVELOPMENT CODE. CONSTRUCT AS DIRECTED OR AS SHOWN ON PLANS. DO NOT ENTER PRIVATE PROPERTY WITHOUT APPROPRIATE PERMIT OR EASEMENT. MATERIAL WITHIN THE ROW SHALL BE CONCRETE.
  - CHECK THE GUTTER FLOW DEPTH AT DRIVEWAY LOCATIONS TO ASSURE THAT THE DESIGN FLOOD DOES NOT OVERTOP THE BACK OF SIDEWALK AT DRIVEWAY. IF OVERTOPPING OCCURS PLACE AN INLET AT UPSTREAM SIDE OF DRIVEWAY OR PERFORM OTHER APPROVED DESIGN MITIGATION.
  - #4 REBAR (2'0" ON CENTER, TO BE SUSPENDED TO CENTER OF CONCRETE DEPTH) REQUIRED IN COMMERCIAL AND INDUSTRIAL DRIVEWAYS AND IN PUBLIC ALLEYS. 6"x6" 10 GAUGE MINIMUM WELDED WIRE MAY BE USED IN LIEU OF REBAR.
  - CONCRETE DRIVEWAY APRON REQUIRED WHERE SIDEWALK AND/OR CURB IS EXISTING/PROPOSED, OTHERWISE AN ASPHALT APPROACH CAN BE INSTALLED TO EDGE OF PAVEMENT TO SIMILAR WIDTHS OF THE DRIVEWAY APRON AS APPROVED BY THE CITY ENGINEER.
  - REFER TO THE BEND DEVELOPMENT CODE 3.1.400 AND 3.6.200 FOR NUMBER AND WIDTH OF APRONS PERMITTED PER LOT.
  - THIS SAME STANDARD APPLIES TO ALLEYS
  - WHERE ON A LOW STRESS ROUTE, THE SIDEWALK/PATH WIDTH THROUGH THE DRIVEWAY APRON MUST BE MAINTAINED.
  - NO PAVERS OR HEATED SIDEWALKS/APRONS ARE PERMITTED WITHIN THE RIGHT OF WAY.

DRAWN CJH DIV ROADWAY REV DATE		<b>CITY OF BEND</b> STANDARD DRAWING 710 NW WALL ST., BEND, OREGON 97701	SCALE NTS
<b>CITY OF BEND</b>			DATE 11/01/2024
		DRIVEWAY APPROACH, CURB-TIGHT, WRAPPING SIDEWALK (ALTERNATE E)	APPR
			STD DWG R-5E

TABLE 1 - APPROACH WIDTH (W) - REFER TO NOTE 4

TYPE	WIDTH
RESIDENTIAL	10' - 24'
SINGLE FAMILY	10'-24'
TOWNHOME	32' MAX SHARED; 16' MAX LOCAL STREETS
DUPLEX	SUM 32' MAX (2 APRON MAX)
TRIPLEX	SUM 32' MAX (3 APRON MAX)
QUADPLEX	SUM 32' MAX (4 APRON MAX)
MULTIFAMILY	20' - 30'
COMMERCIAL	10' - 35'

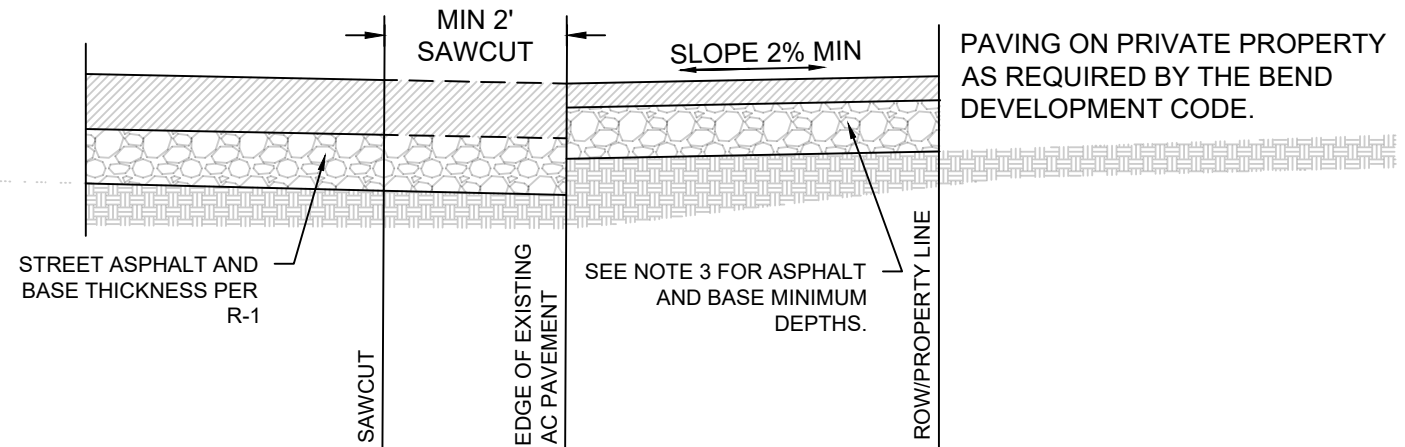
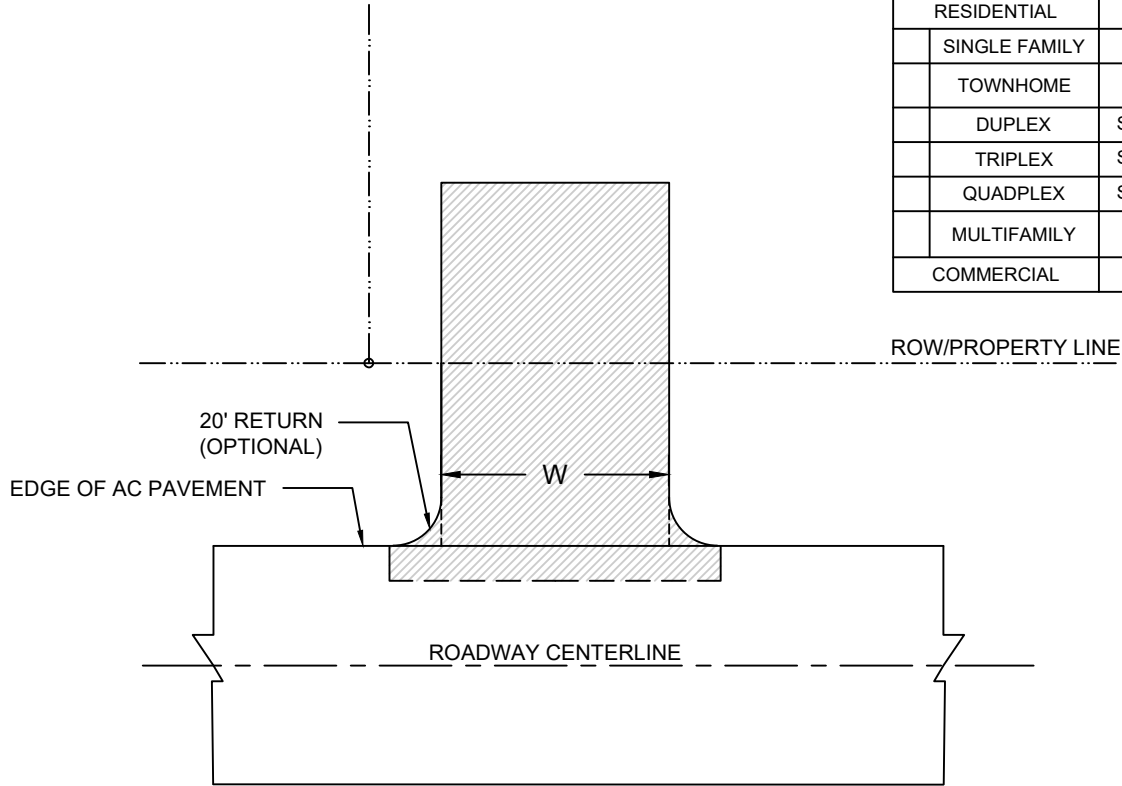

GENERAL NOTES:

1. CONCRETE DRIVEWAY APRONS REQUIRED WHERE SIDEWALK AND/OR CURB IS EXISTING OR PROPOSED, OTHERWISE AN ASPHALT APPROACH CAN BE INSTALLED TO EDGE OF PAVEMENT TO SIMILAR WIDTHS OF THE DRIVEWAY APRON AS APPROVED BY THE CITY ENGINEER.
2. NO PAVERS OR HEATED APRONS ARE PERMITTED WITHIN THE RIGHT OF WAY.
3. COMMERCIAL OR INDUSTRIAL USE MUST BE CONSTRUCTED TO A MINIMUM 4" ASPHALT OVER MINIMUM 6" BASE ROCK. RESIDENTIAL LOTS MUST HAVE NOT LESS THAN 2" ASPHALT OVER 4" BASED ROCK.
4. REFER TO THE BEND DEVELOPMENT CODE 3.1.400 AND 3.6.200 FOR NUMBER AND WIDTH OF APRONS PERMITTED PER LOT.

DRAWN CJH DIV ROADWAY REV DATE	 <b>CITY OF BEND</b>	<b>CITY OF BEND</b> STANDARD DRAWING 710 NW WALL ST., BEND, OREGON 97701	SCALE NTS
			DATE 11/01/2024
		DRIVEWAY APPROACH, ASPHALT	APPR
			STD DWG R-5F

GENERAL NOTES :

1. CITY OF BEND STD DWGS R-6, R-6A, R-6B, AND R-6C ARE INTENDED AS A SUMMARY OF PROWAG REQUIREMENTS. SEE CURRENT PROWAG GUIDELINES FOR COMPLETE REQUIREMENTS.
2. SLOPES USED FOR DESIGN ARE TYPICALLY LESS THAN THE MAXIMUMS TO ALLOW FOR CONSTRUCTION TOLERANCES. RECOMMENDED DESIGN SLOPES ARE AS FOLLOWS:

PROWAG MAX. SLOPE	DESIGN MAX. SLOPE
1:10 (10%)	9.5%
1:12 (8.33%)	7.5%
1:20 (5.0%)	4.5%
1:50 (2%)	1.5%

3. GRADE BREAKS ARE NOT PERMITTED ON THE SURFACE OF CURB RAMPS, BLENDED TRANSITIONS, LANDINGS, AND GUTTER AREAS WITHIN THE PEDESTRIAN ACCESS ROUTE.
4. THE COUNTER SLOPE OF THE GUTTER OR STREET AT THE FOOT OF A CURB RAMP, LANDING, OR BLENDED TRANSITION SHALL BE 5% MAXIMUM.
5. SURFACES OF CURB RAMPS, BLENDED TRANSITIONS, AND LANDINGS SHALL COMPLY WITH R302.7. GRATINGS, ACCESS COVERS, AND OTHER APPURTENANCES SHALL NOT BE LOCATED ON CURB RAMPS, LANDINGS, BLENDED TRANSITIONS AND GUTTERS WITHIN THE PEDESTRIAN ACCESS ROUTE.
6. SURFACE DISCONTINUITIES SHALL NOT EXCEED 0.5 in. MAXIMUM. VERTICAL DISCONTINUITIES BETWEEN 0.25 in. AND 0.5 in. MAXIMUM SHALL BE BEVELED AT 1:2 MINIMUM. THE BEVEL SHALL BE APPLIED ACROSS THE ENTIRE LEVEL CHANGE. SEE PROWAG R302.7.2.
7. WHERE SIDEWALKS ARE CONSTRUCTED OUTSIDE THE RIGHT OF WAY, A PUBLIC ACCESS EASEMENT MUST BE RECORDED OVER THE PRIVATE PROPERTY ENCROACHMENT.
8. 6 INCHES OF COMMERCIAL GRADE CONCRETE PER CITY SPEC 00440 AND 4 INCHES OF STATE SPEC AGGREGATE PER CITY SPEC 00640/00641 IS REQUIRED FOR CONSTRUCTION OF CURB RAMPS, FLARES, AND LANDINGS.
9. DETECTABLE WARNING SURFACES COMPLYING WITH PROWAG R305 SHALL BE PROVIDED, WHERE A CURB RAMP, LANDING, OR BLENDED TRANSITION CONNECTS TO A STREET.
10. DETECTABLE WARNING SURFACES SHALL EXTEND 24 in. MINIMUM IN THE DIRECTION OF TRAVEL AND THE FULL WIDTH OF THE CURB RAMP (EXCLUSIVE OF FLARES), THE LANDING, OR THE BLENDED TRANSITION.
11. THE ROWS OF TRUNCATED DOMES IN A DETECTABLE WARNING SURFACE SHALL BE ALIGNED TO BE PERPENDICULAR OR RADIAL TO THE GRADE BREAK BETWEEN THE RAMP, LANDING, OR BLENDED TRANSITION AND THE STREET.
12. THE CLEAR WIDTH OF LANDINGS BLENDED TRANSITIONS, AND CURB RAMPS, EXCLUDING FLARES, SHALL BE 4.0 FT. MINIMUM.

DRAWN AJD	
DIV ROADWAY	
REV	DATE



CITY OF BEND

CITY OF BEND

STANDARD DRAWING

710 NW WALL ST., BEND, OREGON 97701

CURB RAMP GENERAL NOTES

SCALE NTS

DATE 01/31/2022

APPR

STD DWG R-6

CURB EXPOSURE TO BE MINIMUM 3-INCHES (6-INCH PREFERRED) BETWEEN RAMPS UNLESS OTHERWISE APPROVED.

GRADE BREAKS AT THE TOP AND BOTTOM OF PERPENDICULAR CURB RAMPS SHALL BE PERPENDICULAR TO THE DIRECTION OF RAMP RUN. AT LEAST ONE END OF THE BOTTOM GRADE BREAK SHALL BE AT THE BACK OF CURB. THE GRADE FROM THE BOTTOM OF THE DETECTABLE WARNING TO THE LANDING SHALL BE A CONTINUOUS GRADE (5% MAXIMUM). SURFACE SLOPES THAT MEET THE GRADE BREAKS SHALL BE FLUSH.

FLARED SIDES ARE PREFERRED, PARTICULARLY WHERE SUBJECT TO DAMAGE FROM ONCOMING TRAFFIC AND SNOWPLOWS. IF ADJACENT CONSTRAINTS PREVENT FLARE CONSTRUCTION, SIDE OF RAMPS MAY BE RETURNED IF PROTECTED FROM CROSS TRAVEL BY LANDSCAPING, STREET FURNITURE, POLES, OR EQUIPMENT.

ONE CORNER OF THE DETECTABLE WARNING MUST BE WITHIN 2 in. OF THE GRADE BREAK; NO OTHER POINT ON THE LEADING EDGE OF THE DETECTABLE WARNING MAY BE MORE THAN 5 ft. FROM THE BACK OF CURB.

WHERE BOTH ENDS OF THE BOTTOM GRADE BREAK, COMPLYING WITH PROWAG R305.2.1, ARE 5.0 ft. OR LESS FROM THE BACK OF CURB, THE DETECTABLE WARNING SHALL BE LOCATED ON THE RAMP SURFACE AT THE BOTTOM GRADE BREAK. WHERE EITHER END OF THE BOTTOM GRADE BREAK IS MORE THAN 5.0 ft. FROM THE BACK OF CURB, THE DETECTABLE WARNING SHALL BE LOCATED ON THE LOWER LANDING.

FLARED SIDES WITH A SLOPE OF 10% MAXIMUM, MEASURED PARALLEL TO THE CURB LINE, SHALL BE PROVIDED WHERE A PEDESTRIAN CIRCULATION PATH CROSSES THE CURB RAMP OR WHEN THE FLARE ABUTS A HARD SURFACE.

FLARES REQUIRED UNLESS BARRIERS EXIST OR WHERE APPROVED BY THE CITY ENGINEER. FLARE SLOPE CAN EXCEED 10% WHERE ABUTTING MIN 2' LANDSCAPING AREA.

A LANDING 5.0 ft. MINIMUM BY 5.0 ft. MINIMUM SHALL BE PROVIDED AT THE TOP OF THE CURB RAMP AND SHALL BE PERMITTED TO OVERLAP OTHER LANDINGS AND CLEAR SPACE. RUNNING AND CROSS SLOPES AT INTERSECTIONS SHALL BE 2% MAXIMUM.

**PERPENDICULAR CURB RAMPS**  
 THE RUNNING SLOPE SHALL BE 5% MINIMUM AND 8.3% MAXIMUM BUT SHALL NOT REQUIRE THE RAMP LENGTH TO EXCEED 15.0 FT.  
 BLENDED TRANSITIONS SHALL COMPLY WITH R303.3. RUNNING SLOPE SHALL BE 5% MAXIMUM AND CROSS SLOPE SHALL BE 2% MAXIMUM.  
 THE RAMP CROSS SLOPE SHALL NOT EXCEED 2% AT YIELD OR STOP CONTROLLED INTERSECTIONS. AT UNCONTROLLED INTERSECTIONS, THE CROSS SLOPE MAY TRANSITION FROM 2% AT THE LANDING UP TO 5% AT THE CURB. AT MIDBLOCK CROSSINGS, THE CROSS SLOPE MAY TRANSITION TO MATCH THE ROAD GRADE.  
 WIDTH OF RAMP TO MATCH SUP/SIDEWALK STANDARD WIDTH FOR ROAD CROSS-SECTION; ALTERNATE MAY BE APPROVED BY CITY ENGINEER IN EXISTING NON-COMPLIANT AREAS WITH NO PLANS FOR SIDEWALK UPGRADES.

TRANSITION PANEL FROM RAMP TO EXISTING SIDEWALK (WHERE REQUIRED TO MATCH EX. SIDEWALK CROSS SLOPE). MAX. GRADES ARE NOT SPECIFIED BY PROWAG. ADJUST LENGTH AS NEEDED TO PROVIDE 0.5% CHANGE PER FT. IF PROPOSED MATCH LINE LOCATION FALLS WITHIN 2 FEET FROM AN EXISTING JOINT IN THE SECTION OF SIDEWALK TO REMAIN, THE EXISTING WALK SHALL BE REMOVED BACK TO THE NEXT JOINT.

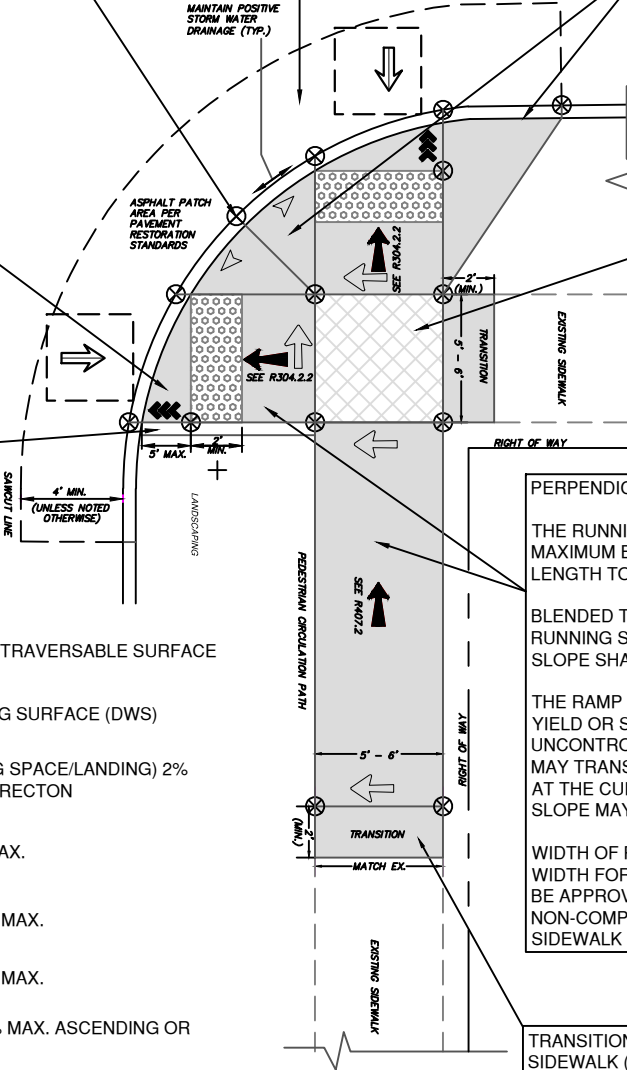

- SIDEWALK OR OTHER TRAVERSABLE SURFACE
- DETECTABLE WARNING SURFACE (DWS)
- LEVEL AREA (TURNING SPACE/LANDING) 2% MAX. SLOPE IN ANY DIRECTION
- CROSS SLOPE 2.0% MAX.
- RUNNING SLOPE 5.0% MAX.
- RUNNING SLOPE 8.3% MAX.
- COUNTER SLOPE 5.0% MAX. ASCENDING OR DESCENDING
- FLARE SLOPE 10% MAX.
- 4'X4' CLEAR SPACE
- REQUIRED DESIGN ELEVATIONS SLOPES TO BE SHOWN WITH DESIGN

TYPICAL PERPENDICULAR CURB RAMP  
 ACCORDING TO PROWAG REQUIREMENTS  
 NOT TO SCALE - ROTATED TO FIT

DRAWN	AJD
DIV	ROADWAY
REV	DATE



CITY OF BEND  
 STANDARD DRAWING

710 NW WALL ST., BEND, OREGON 97701

TYPICAL PERPENDICULAR CURB RAMP

SCALE	NTS
DATE	01/31/2022
APPR	
STD DWG	R-6A

TRANSITION PANEL FROM RAMP TO EXISTING SIDEWALK (WHERE REQUIRED TO MATCH EX. SIDEWALK CROSS SLOPE). MAX. GRADES ARE NOT SPECIFIED BY PROWAG. ADJUST LENGTH AS NEEDED TO PROVIDE SMOOTH TRANSITION. IF PROPOSED MATCH LINE LOCATION FALLS WITHIN 2 FEET FROM AN EXISTING JOINT IN THE SECTION OF SIDEWALK TO REMAIN, THE EXISTING WALK SHALL BE REMOVED BACK TO THE NEXT JOINT.

GRADE BREAKS AT THE TOP AND BOTTOM OF PARALLEL CURB RAMPS SHALL BE PERPENDICULAR TO THE DIRECTION OF RAMP RUN. SURFACE SLOPES THAT MEET THE GRADE BREAKS SHALL BE FLUSH.

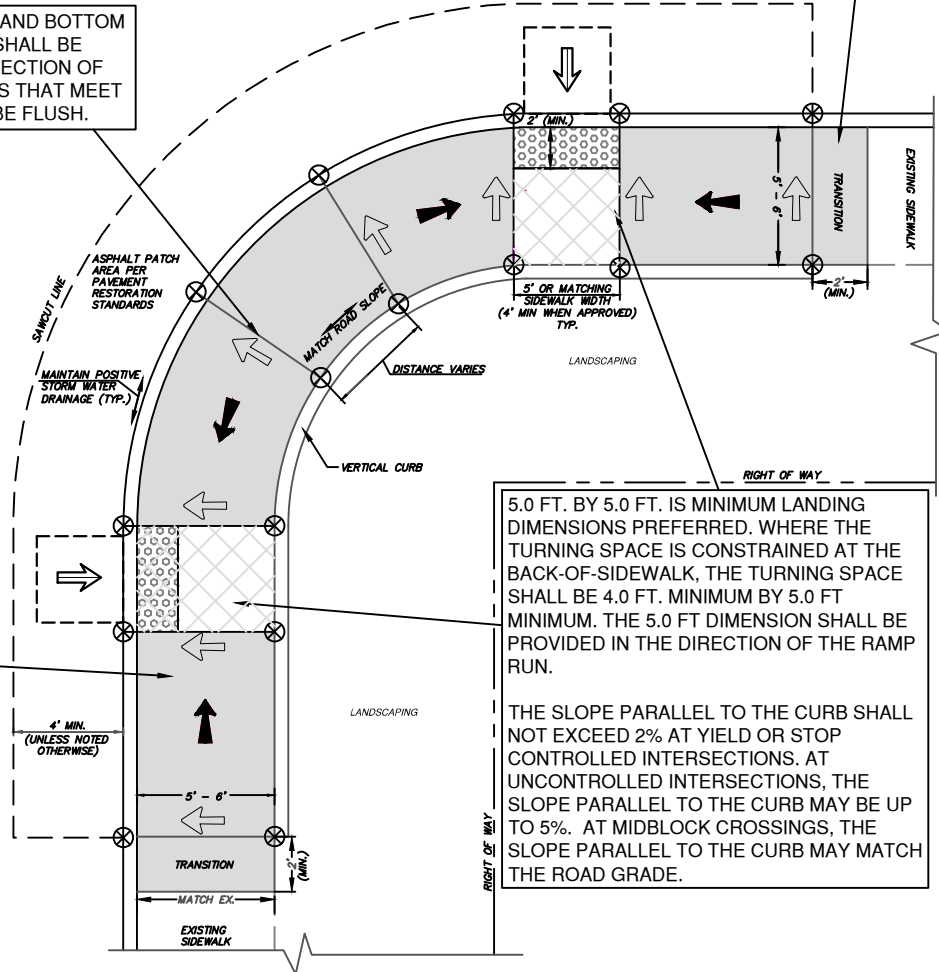

**PARALLEL CURB RAMPS**

THE RUNNING SLOPE SHALL BE 8.33% MAXIMUM BUT SHALL NOT REQUIRE THE RAMP LENGTH TO EXCEED 15.0 FT.

THE CROSS SLOPE SHALL BE 2% MAXIMUM.







THE CLEAR WIDTH OF LANDINGS BLENDED TRANSITIONS, AND CURB RAMPS, EXCLUDING FLARES, SHALL BE 4.0 FT. MINIMUM.

LANDING WIDTH SHALL MATCH THE ADJACENT SIDEWALK WIDTH, 5.0 FT MIN., UNLESS OTHERWISE APPROVED.

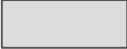
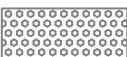
5.0 FT. BY 5.0 FT. IS MINIMUM LANDING DIMENSIONS PREFERRED. WHERE THE TURNING SPACE IS CONSTRAINED AT THE BACK-OF-SIDEWALK, THE TURNING SPACE SHALL BE 4.0 FT. MINIMUM BY 5.0 FT MINIMUM. THE 5.0 FT DIMENSION SHALL BE PROVIDED IN THE DIRECTION OF THE RAMP RUN.

THE SLOPE PARALLEL TO THE CURB SHALL NOT EXCEED 2% AT YIELD OR STOP CONTROLLED INTERSECTIONS. AT UNCONTROLLED INTERSECTIONS, THE SLOPE PARALLEL TO THE CURB MAY BE UP TO 5%. AT MIDBLOCK CROSSINGS, THE SLOPE PARALLEL TO THE CURB MAY MATCH THE ROAD GRADE.

TYPICAL PARALLEL CURB RAMP  
ACCORDING TO PROWAG REQUIREMENTS  
NOT TO SCALE - ROTATED TO FIT

-  SIDEWALK OR OTHER TRAVERSABLE SURFACE
-  DETECTABLE WARNING SURFACE (DWS)
-  LEVEL AREA (TURNING SPACE/LANDING)  
2% MAX. SLOPE IN ANY DIRECTION
-  CROSS SLOPE 2.0% MAX.
-  RUNNING SLOPE 8.3% MAX.
-  COUNTER SLOPE 5.0% MAX. ASCENDING OR DESCENDING
-  4'X4' CLEAR SPACE
-  REQUIRED DESIGN ELEVATIONS  
SLOPES TO BE SHOWN WITH DESIGN

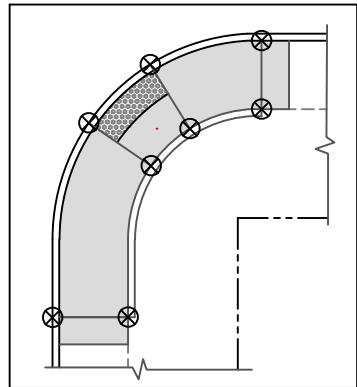

TYPICAL DIAGONAL CURB RAMP  
REQUIRES CITY APPROVAL FOR CONSTRUCTION  
ACCORDING TO PROWAG REQUIREMENTS  
NOT TO SCALE - ROTATED TO FIT

NOTE: DIAGONAL CURB RAMP ALTERNATE IS ONLY ALLOWED WHEN DIRECTIONAL RAMPS ARE NOT POSSIBLE AND MUST BE APPROVED BY THE CITY ENGINEER.

DRAWN	AJD
DIV	ROADWAY
REV	DATE



**CITY OF BEND**  
STANDARD DRAWING  
710 NW WALL ST., BEND, OREGON 97701

**TYPICAL PARALLEL CURB RAMP**

SCALE	NTS
DATE	01/31/2022
APPR	
STD DWG	R-6B

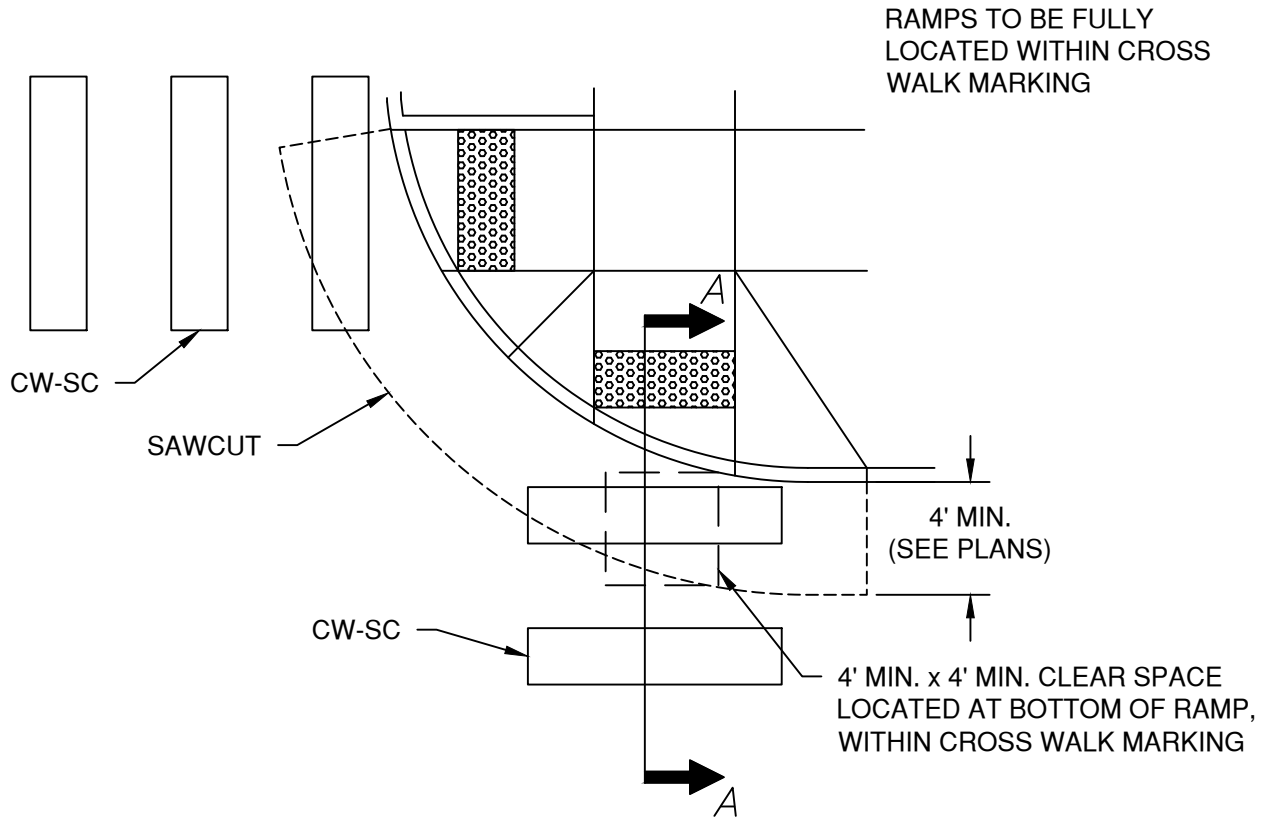

**CROSS WALK - CURB RAMP ORIENTATION**  
*NOT TO SCALE*

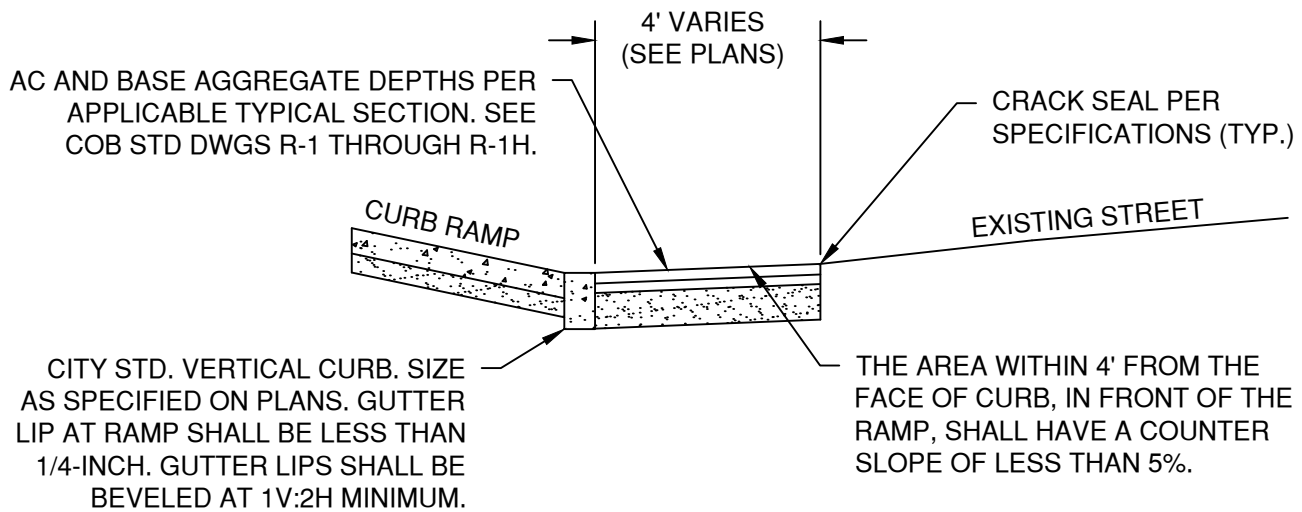

NOTE: IN AREAS WITH UNIT PAVER CROSS WALKS, REMOVE EXISTING PAVERS, AND RE-INSTALL AT GRADES TO ACHIEVE THESE REQUIREMENTS.

**TYPICAL RAMP / ASPHALT PATCH SECTION**  
*NOT TO SCALE*

DRAWN ARI	
DIV ROADWAY	
REV	DATE



**CITY OF BEND**  
 STANDARD DRAWING  
 710 NW WALL ST., BEND, OREGON 97701

**CURB RAMP DETAILS**

SCALE NTS
DATE 04/16/2026
APPR
STD DWG R-6C

## INSTALLATION IN NEW CONSTRUCTION

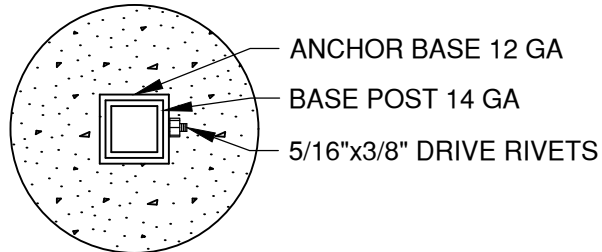

SECTION A-A

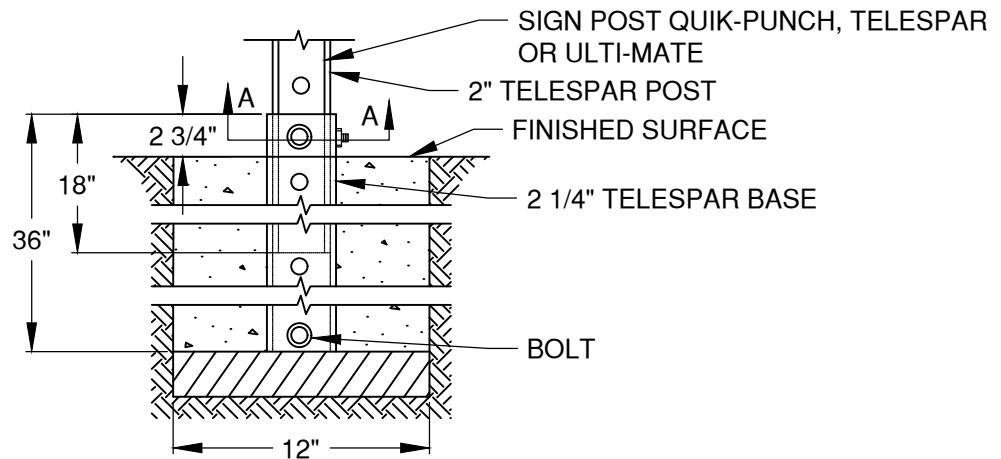

ANCHOR BASE DETAIL

**NOTES:**

1. USE PSST ANCHOR BASE FOUNDATION FOR ALL SIGN LOCATIONS OTHER THAN IN MEDIANS AND ROUNDABOUT SPLITTER ISLANDS PER STD DWG R-7A.
2. ANCHOR BASE HOLES AND BOTTOM OF ANCHOR BASE SHALL BE COVERED SO THAT CONCRETE DOES NOT SEEP INTO ANCHOR BASE DURING SETTING
3. BASE SHOULD BE SET SEPARATELY FROM POST WITH ANCHOR BOLT IN BASE BOTTOM ONLY
4. POST SHOULD BE ABLE TO SLIDE FREELY WHEN RIVET IS REMOVED
5. FOR LARGE SIGNS THAT EXCEED WINDLOADS 2 1/2" POSTS MAY BE APPROVED BY CITY ENGINEER

DRAWN AJD DIV ROADWAY REV    DATE	 <b>CITY OF BEND</b>	<b>CITY OF BEND</b> STANDARD DRAWING <small>710 NW WALL ST., BEND, OREGON 97701</small>	SCALE NTS DATE 01/31/2022 APPR STD DWG R-7
		<b>PSST ANCHOR BASE FOUNDATION</b>	

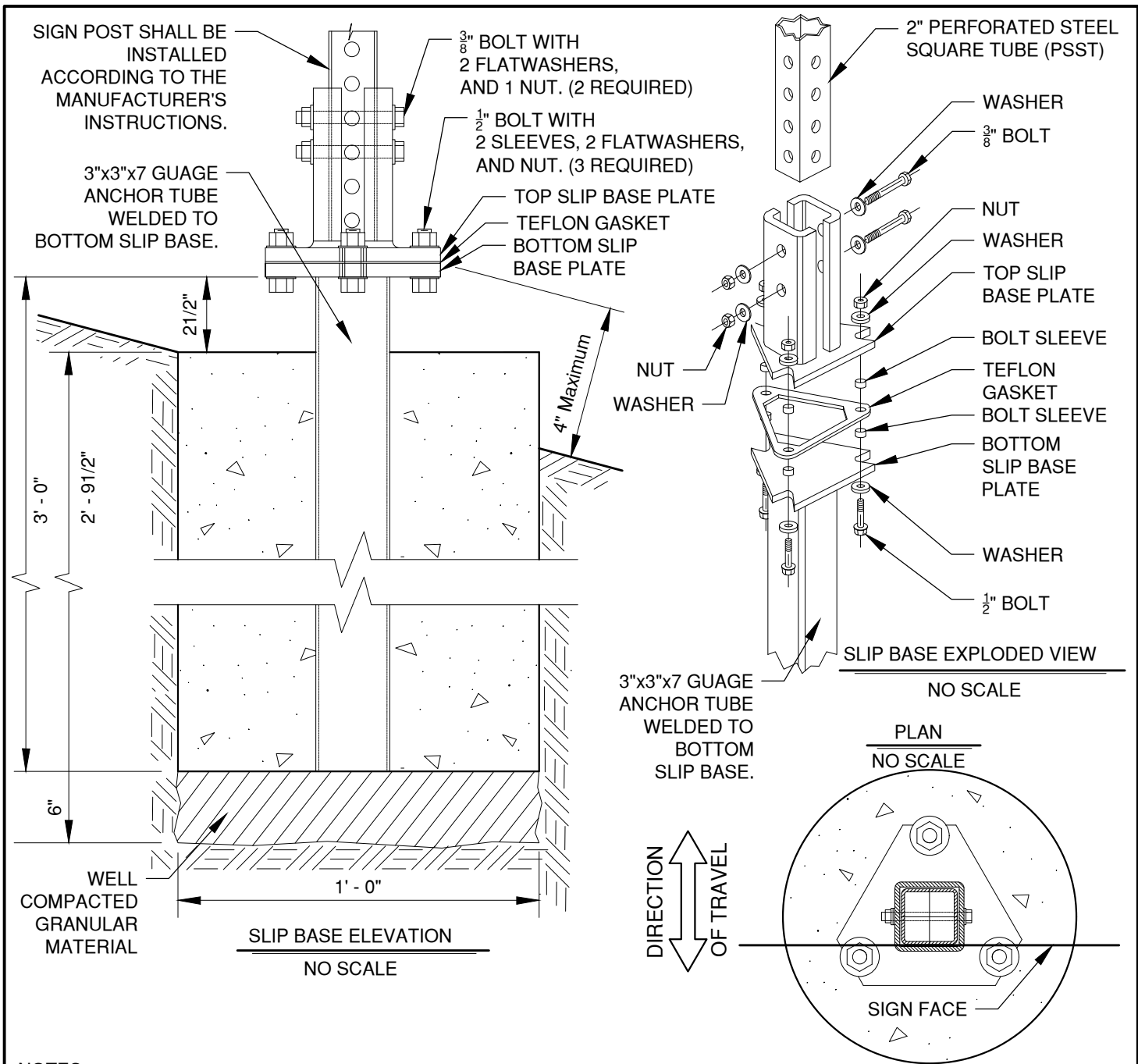

**NOTES:**

1. USE PSST SLIP BASE FOUNDATION FOR SIGNS INSTALLED IN MEDIANS AND ROUNDABOUT SPLITTER ISLANDS.
2. MATERIAL GRADE FOR BASE HARDWARE CONNECTION SHALL BE ACCORDING TO THE MANUFACTURER'S RECOMMENDATION AND BASED ON CRASH TESTING.
3. SLIP BASE STEEL SHALL BE HOT DIPPED GALVANIZED OR APPROVAL EQUAL.
4. FOOTING CONCRETE SHALL BE COMMERCIAL GRADE CONCRETE (FC=3000PSI) PER SPECIFICATION 00440. THE CGC MIXTURE MAY BE ACCEPTED AT THE SITE OF PLACEMENT ACCORDING TO 00440.14.
5. ALL SLIP BASES SHALL BE PRE-ASSEMBLED BY THE MANUFACTURER AND SHALL BE INSTALLED ACCORDING TO THE MANUFACTURER'S INSTRUCTIONS.
6. SLIP BASE DETAILS SHOWN ARE NOT FOR A SPECIFIC MANUFACTURER AND ARE ONLY SHOWN TO CONVEY GENERAL PIECES OF A SLIP BASE SYSTEM. SPECIFIC SLIP BASE MATERIAL WILL BE ACCORDING TO THE MANUFACTURER'S DOCUMENTATION.
7. FOR LARGE SIGNS THAT EXCEED WINDLOADS, 2 1/2" PSST MAY BE APPROVED BY CITY ENGINEER

DRAWN <b>AJD</b> DIV <b>ROADWAY</b> REV    DATE	 <b>CITY OF BEND</b>	<b>CITY OF BEND</b> STANDARD DRAWING 710 NW WALL ST., BEND, OREGON 97701	SCALE <b>NTS</b> DATE <b>01/31/2022</b> APPR STD DWG <b>R-7A</b>
<b>PSST SLIP BASE FOUNDATION</b>			

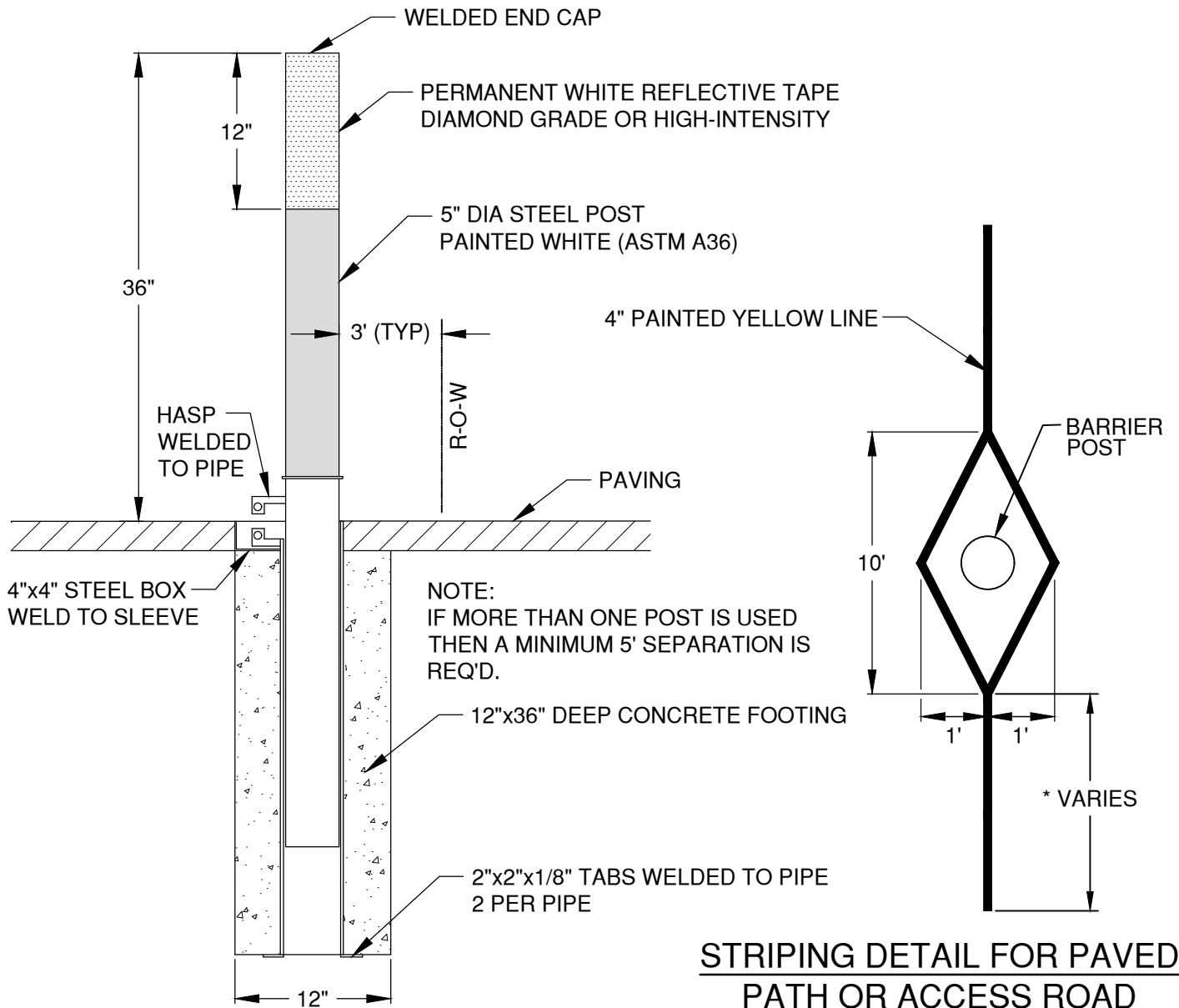

### STRIPING DETAIL FOR PAVED PATH OR ACCESS ROAD

\* Length of approach line varies by location, where possible, 25' min.

**NOTES:**

1. POSTS OR BOLLARDS SHALL BE SET BACK BEYOND THE CLEAR ZONE OF THE ADJACENT STREET OR BE OF A BREAKAWAY DESIGN. THE POST SHALL BE PERMANENTLY REFLECTORIZED FOR NIGHTTIME VISIBILITY AND PAINTED WHITE FOR IMPROVED DAYTIME AND NIGHT TIME VISIBILITY.
2. ON PAVED PATHS OR ACCESS ROADS, APPLY PAVEMENT MARKINGS PER STRIPING DETAIL.

DRAWN AJD	
DIV ROADWAY	
REV	DATE



CITY OF BEND

**CITY OF BEND**

STANDARD DRAWING

710 NW WALL ST., BEND, OREGON 97701

**REMOVABLE POST AND MARKINGS**

SCALE NTS

DATE 01/31/2022

APPR

STD DWG R-7B

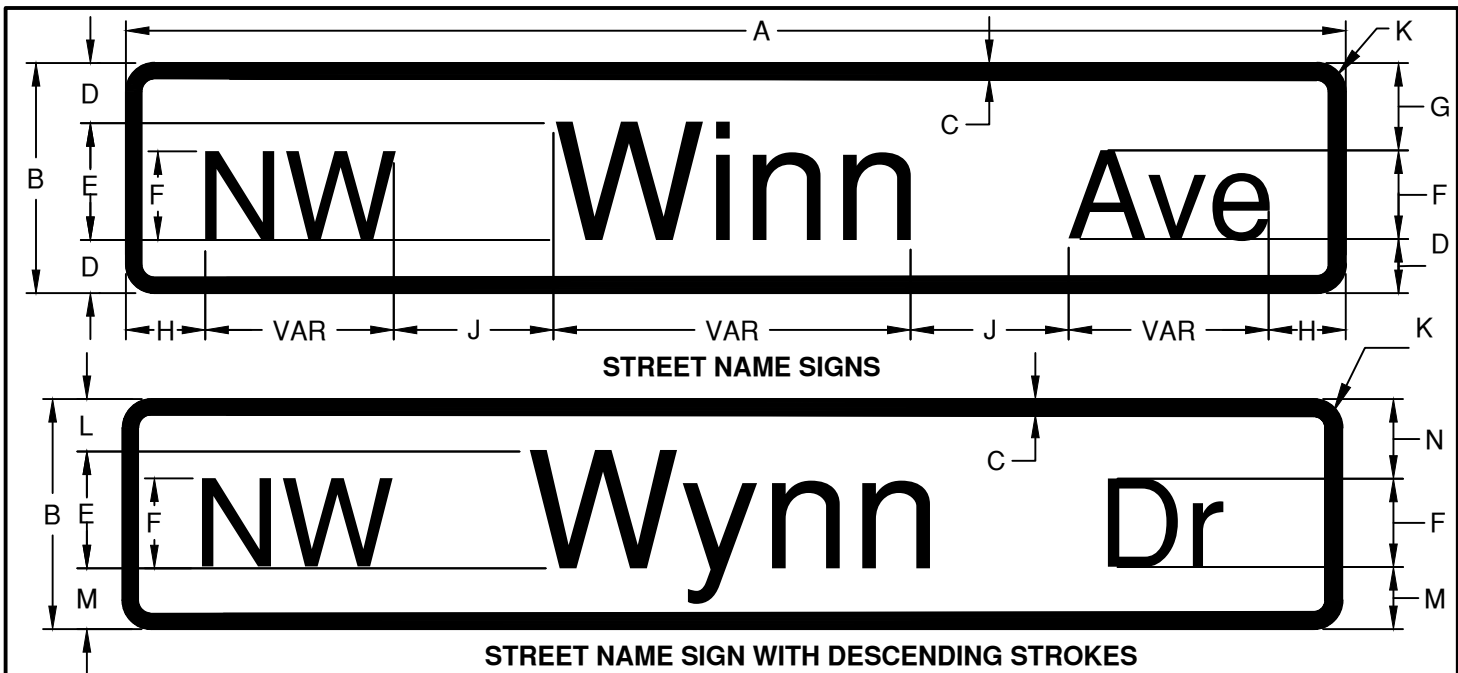

SIGN LOCATION	DIMENSIONS												
	A	B	C	D	E	F	G	H	J	K	L	M	N
LOCAL	VAR	8	0.375	2	4C	3C	3	3 MIN	3	1	1.75	2.25	2.75
COLLECTOR/ ARTERIAL ≤ 40MPH	VAR	12	0.5	3	6C	4.5C	5	4.5 MIN	4.5	1.5	2.75	3.25	4.75
COLLECTOR/ ARTERIAL > 40 MPH	VAR	18	0.75	5	8C	6C	7.67	5.33 MIN	6	1.875	5	5	7.67
OVERHEAD	VAR	24	1	6	12C	9C	10	9 MIN	9	2.25	5	6	9.50

- NOTES:
- SIGNS INSTALLED ALONG PUBLIC STREETS SHALL BE FABRICATED AND INSTALLED TO CONFORM TO THE MUTCD AND CITY OF BEND SPECIFICATIONS.
  - UNLESS OTHERWISE SPECIFIED, STREET NAME SIGNS SHALL BE FABRICATED AS FOLLOWS:
    - SIGN SUBSTRATE: SHEET ALUMINUM (GAUGE 0.80 FOR GROUND-MOUNT) WITH ROUNDED CORNERS
    - RETRO-REFLECTIVE SHEETING: GREEN BACKGROUND WITH WHITE LEGEND, USING HIP/TYPAGE G FOR GROUND-MOUNTED SIGNS, AND DIAMOND GRADE/TYPAGE G2 FOR SIGNS MOUNTED OVERHEAD;
    - LETTERING SHALL BE LOWER-CASE WITH INITIAL UPPER-CASE LETTERS;
    - SERIES C2000 FONT, WITH LETTERING AND LETTER SPACING PER THE FEDERAL HIGHWAY ADMINISTRATION'S STANDARD ALPHABETS AS SHOWN IN THE CURRENT EDITION OF THE STANDARD HIGHWAY SIGNS AND PAVEMENT MARKINGS MANUAL. (\* EXCEPT FOR OVERHEAD SIGNS, WHERE SIGNS EXCEED 36" LONG, SERIES B2000 FONT SHALL BE USED);
    - BOTTOM STREET SIGNS (CLOSEST TO THE REGULATORY/STOP SIGN) SHALL BE TWO SINGLE-SIDED WITH PREDRILLED HOLES. SIGNS SHALL BE RIVETED BACK TO BACK ON THE SQUARE TUBE POST, CENTERED ON THE POST.
    - BOTTOM STREET SIGNS SHALL BE USED FOR SIDE STREET (STOP CONTROLLED STREET).
    - TOP STREET SIGN SHALL BE DOUBLE SIDED, TOP SIGN USED FOR MAINLINE STREET (NON-STOP CONTROLLED STREET).
  - ALL SIGNS SHALL BE REVIEWED AND APPROVED BY THE CITY OF BEND ENGINEERING DEPARTMENT PRIOR TO FABRICATIONS AND INSTALLATION.
  - TYPICAL INSTALLATION INCLUDES 2-INCH SQUARE TUBE CAPS WITH 90-DEGREE ANGLE BRACKETS ON 2-INCH PERFORATED SQUARE TUBE STEEL POSTS. USE 5- OR 6-INCH BLADE MOUNTS FOR SIGNS LESS THAN 36" WIDE; 12-INCH MOUNTS FOR SIGNS 36-INCHES OR WIDER OR OVER 6-INCHES HIGH. SEE STANDARD DRAWINGS R-7 AND R-9.
  - SIGN WIDTHS VARY WITH LEGEND. WHERE SITE CONSTRAINTS LIMIT AVAILABLE SPACE, REDUCED LETTER HEIGHT, FONT STYLE, LINE SPACING, OR EDGE SPACING WILL BE CONSIDERED. REDUCTIONS IN SPACING BETWEEN LETTERS OR WORDS IS NOT PERMITTED.
  - WHERE PRIVATE STREETS INTERSECT WITH PUBLIC STREETS, INSTALL A BLACK ON YELLOW PRIVATE DR SIGN WITH 4-INCH CAPITAL LETTERS (ODOT SIGN POLICY SIGN #OW14-3) DIRECTLY BELOW THE PRIVATE STREET NAME SIGN (OR ON A SEPARATE POST, IF NOT AT AN INTERSECTION).
  - FOR ADDITIONAL INFORMATION, REFER TO MUTCD SECTION 2A AND 2D, AND CITY OF BEND TECHNICAL SPECIFICATION SECTION 00940.
  - CONFIRM SIGN SIZE WITH CITY ENGINEER FOR SIGNS ON EXISTING TRAFFIC SIGNAL POLES OR MAST ARMS.
  - LARGER SIGNS ARE PLACE PLACED FACING THE FASTER STREET (COLLECTORS AND ARTERIALS).

DRAWN AJD				<b>CITY OF BEND</b> STANDARD DRAWING 710 NW WALL ST., BEND, OREGON 97701				SCALE NTS	
DIV ROADWAY								DATE 11/01/2024	
REV	DATE	APPR		<b>STANDARD STREET NAME SIGNS</b>				APPR	
			STD DWG R-8						

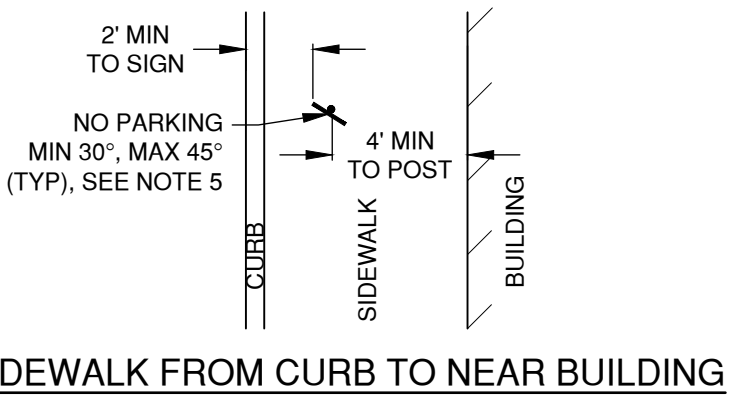
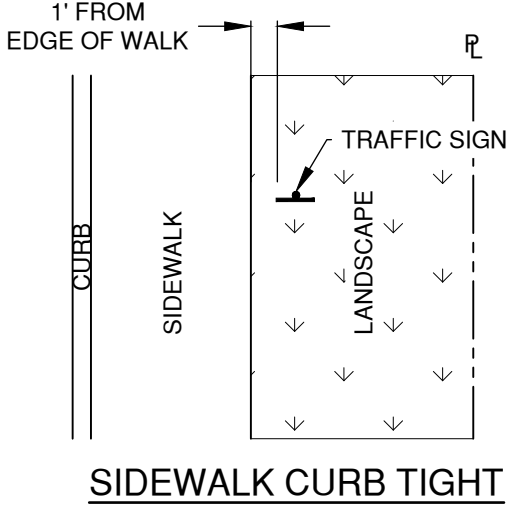
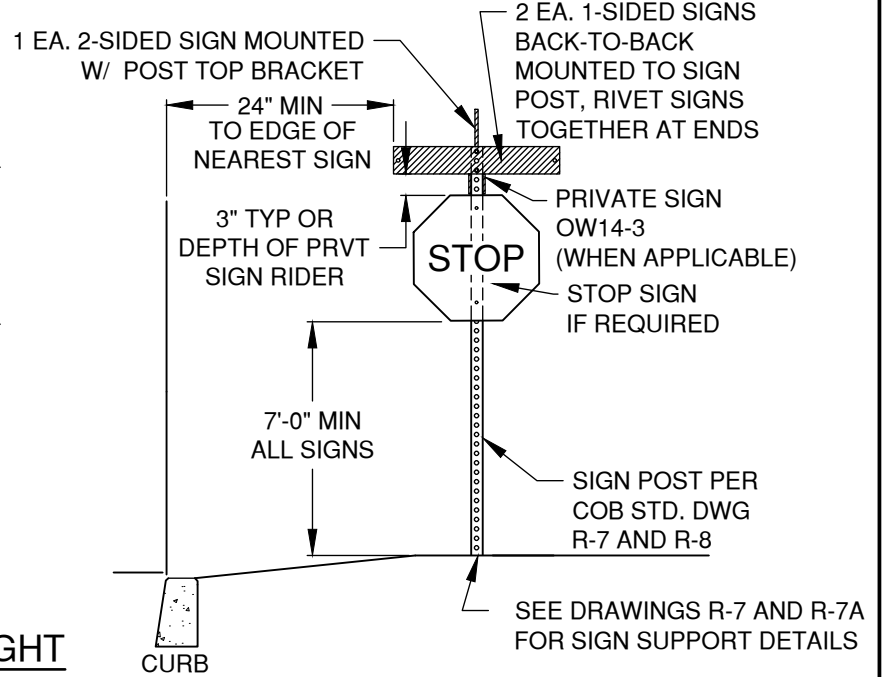
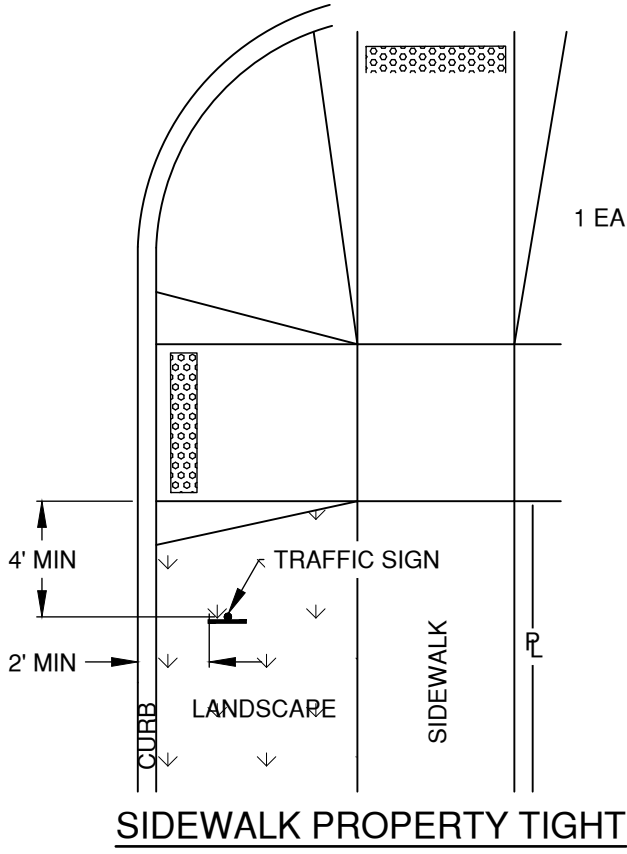

**NOTES:**

1. SET TO MUTCD SPECS
2. SEE R-8 FOR COB STREET NAME SIGN REQUIREMENTS.
3. CHECK THAT SIGN IS NOT OBSCURED BY VEGETATION, TRIM IF NEEDED.
4. INSTALL ALL SIGNS WITH 5/16"X3/8" DRIVE RIVETS.
5. WHERE NO PARKING SIGN IS USED, IT MUST BE ANGLED.

DRAWN AJD	
DIV ROADWAY	
REV	DATE



**CITY OF BEND**  
 STANDARD DRAWING  
 710 NW WALL ST., BEND, OREGON 97701

**STANDARD STREET SIGN PLACEMENT**

SCALE NTS
DATE 04/16/2026
APPR
STD DWG R-9

TABLE A	
PIPE DIA (IN)	"A" (IN)
4	10
6	10
8	10
10	10
12	12
15	12
18	16
21	16
24	18
30	18
36	24
42	24
48	24
54	24
60	24
66	24
72	24

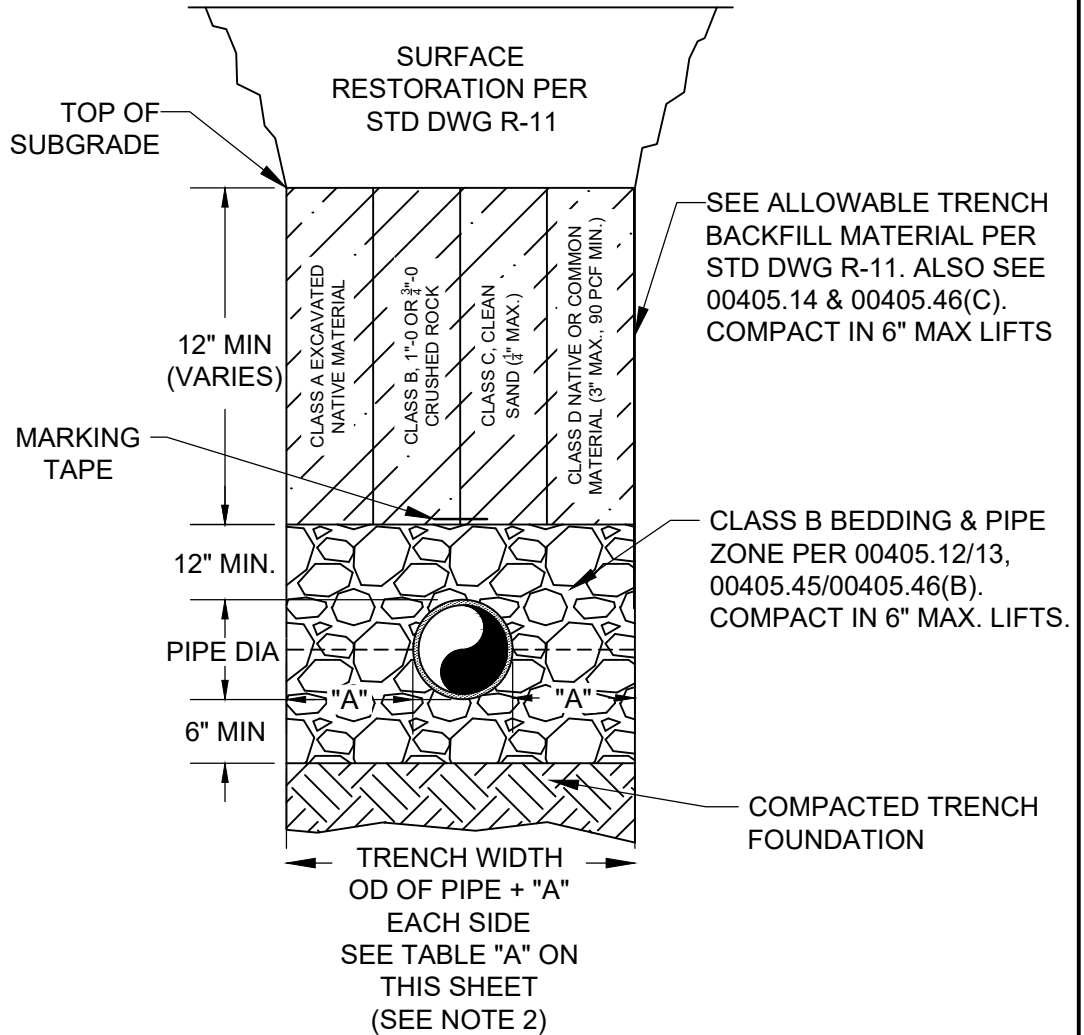

**NOTES:**

1. ALL COMPACTION TO COMPLY WITH SPECIFICATION SECTION 00330.43 AND 00405.46(c).
2. A FRANCHISE UTILITY THAT IS A SINGLE CONDUIT AND IS 4 INCHES IN DIAMETER OR LESS MAY BE CENTERED IN A 12-INCH WIDE TRENCH PROVIDED THAT THE TRENCH CAN ACCOMMODATE THE COMPACTION EQUIPMENT. TRENCH PATCH SHALL BE IN ACCORDANCE WITH STD DWG R-11 WHERE THE TEE PATCH SHALL NOT BE LESS THAN 12 INCHES ON BOTH SIDES OF THE TRENCH. OVERALL WIDTH MAY BE REDUCED FROM 4 FEET, BUT IN NO CIRCUMSTANCES RESULT IN TEE PATCHES LESS THAN 12 INCHES AND AN OVERALL MINIMUM WIDTH OF 3 FEET.
3. CLASS E - CLSM, MAY BE ALLOWED FOR TRENCH BACKFILL WHERE COMPACTION CANNOT BE MET DUE TO THE PRESENCE OF EXISTING UTILITIES

DRAWN	AJD
DIV	ROADWAY
REV	DATE



**CITY OF BEND**

**CITY OF BEND**

STANDARD DRAWING

710 NW WALL ST., BEND, OREGON 97701

**TYPICAL TRENCH SECTION**

SCALE NTS

DATE 01/31/2022

APPR

STD DWG R-10

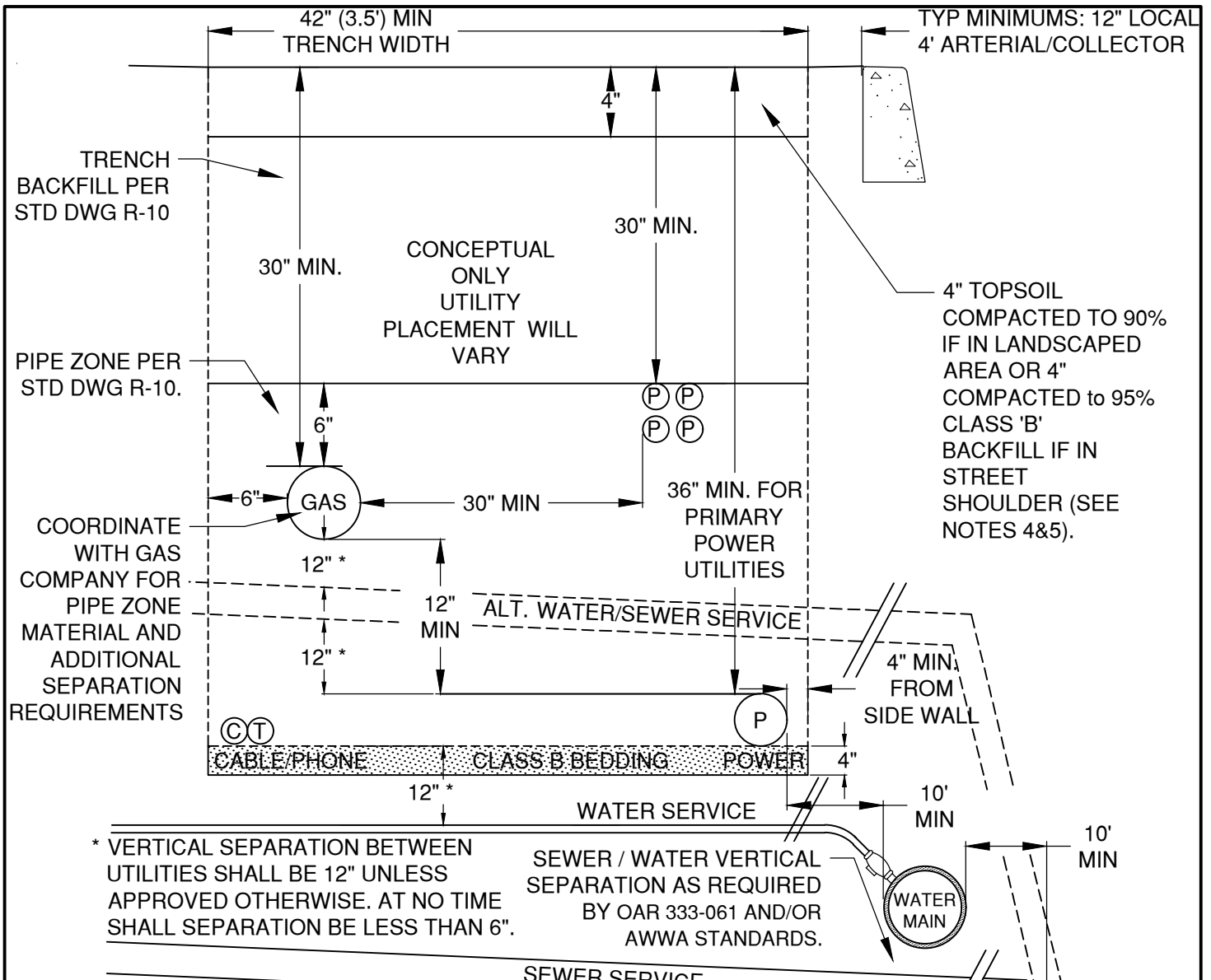

NOTES:

1. ALL COMPACTION TO COMPLY WITH CITY OF BEND STANDARDS.
2. ALL FRANCHISE UTILITIES SHALL BE INSTALLED IN CONDUIT AS APPROVED BY THE FRANCHISE UTILITY HAVING OWNERSHIP.
3. UTILITY SIZES AND LOCATION SHALL BE DETERMINED BY THE UTILITY COMPANY. LOCATION TO BE SHOWN AND APPROVED BY CITY WITH A RIGHT OF WAY (ROW) PERMIT.
4. WHERE STORM SWALES ARE PROPOSED WITHIN THE LANDSCAPE STRIP, FRANCHISE UTILITIES SHALL BE INSTALLED OUTSIDE OF THE SWALE AREA.
5. TOP SOIL LAYER TO BE COMPACTIONED TO 90% MAX DENSITY. WHERE SIDEWALK IS PLACED OVER FRANCHISE UTILITY TRENCH, NO TOP SOIL SHALL BE PLACED AND SIDEWALK TO BE CONSTRUCTED TO COMPLY WITH CITY STANDARDS R-4A AND R-4B
6. STANDARD SHOWN FOR NEW CONSTRUCTION. MODIFICATIONS SHALL BE MADE WHEN WITHIN EXISTING DEVELOPMENTS WHERE APPROVED BY THE CITY ENGINEER.
7. UTILITIES OUTSIDE THE RIGHT OF WAY SHALL BE WITHIN A PUBLIC UTILITIES EASEMENT (PUE). BACKFILL AND INSTALLATION REQUIREMENTS STILL COMPLY WITH THE PUE.
8. NO SWALES OR SURFACE STORMWATER DRAINAGE FACILITIES ARE PERMITTED OVER FRANCHISE UTILITIES.

DRAWN CJH DIV ROADWAY REV DATE		<b>CITY OF BEND</b> STANDARD DRAWING 710 NW WALL ST., BEND, OREGON 97701	SCALE NTS DATE 11/01/2024
		<b>FRANCHISE UTILITY JOINT TRENCH</b>	APPR STD DWG R-10A

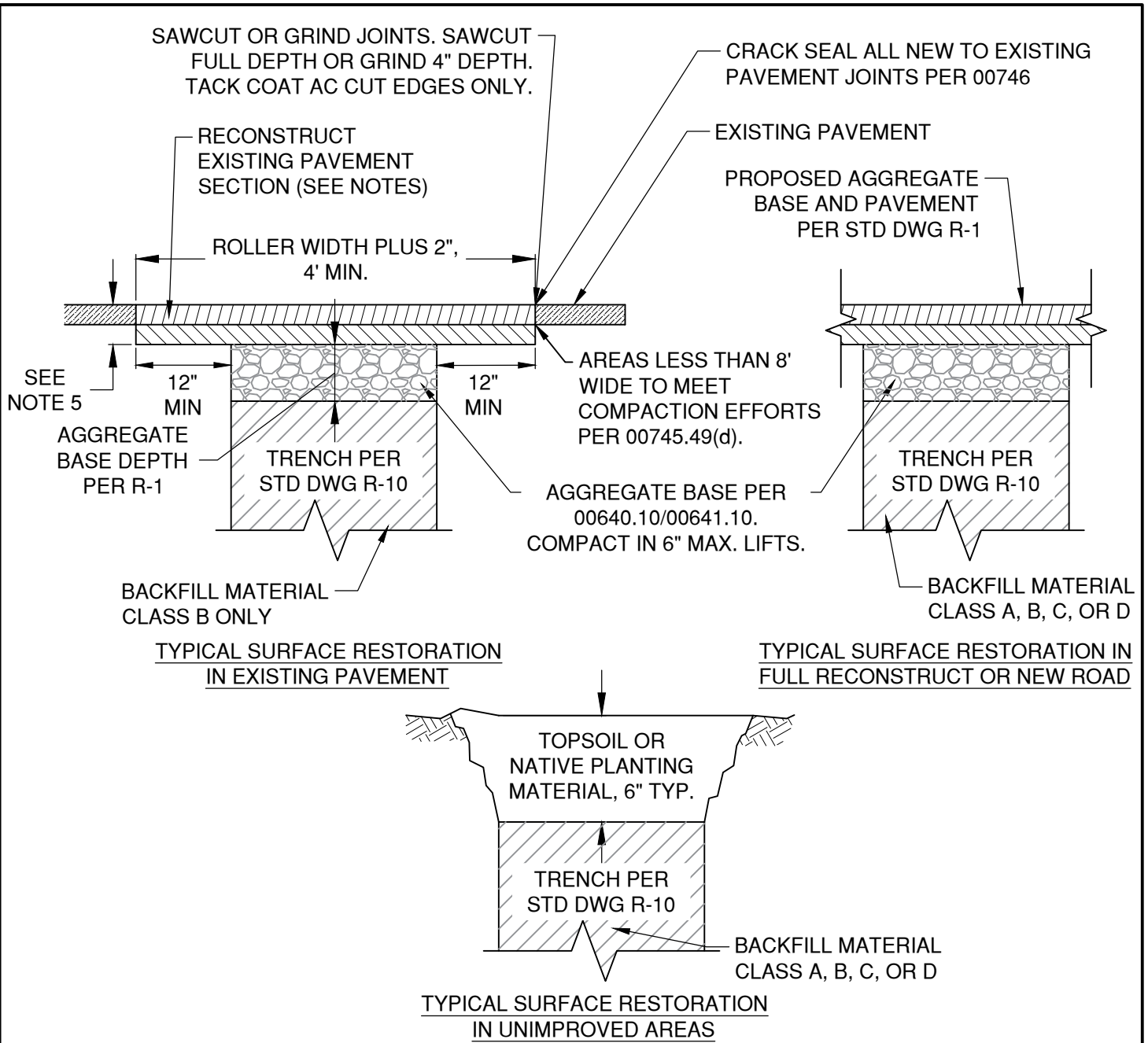

NOTES:

1. SURFACE RESTORATION IN EXISTING PAVEMENT TO COMPLY WITH SPECIFICATION 00495.
2. UNIMPROVED AREA CONSISTS OF ANY PORTION OF THE ROW THAT HAS NOT BEEN IMPROVED TO A CITY STANDARD AND CONSISTS MOSTLY OF NATIVE VEGETATED AREAS. UNIMPROVED AREAS ALSO INCLUDE AREAS WITHIN THE LANDSCAPE STRIP AND PUEs.
3. ALL EXISTING AC OR PCC PAVEMENT SHALL BE SAWCUT PRIOR TO REPAVING. CONCRETE SHALL BE CUT AND REPLACED TO THE NEAREST JOINT(S).
4. CONCRETE PAVEMENT SHALL BE REPLACED WITH CONCRETE TO A MINIMUM THICKNESS OF 6" OR TO THE THICKNESS OF REMOVED PAVEMENT, WHICHEVER IS GREATER
5. PLACE ACP A MINIMUM THICKNESS PER R-1 OR TO THE THICKNESS OF REMOVED PAVEMENT, WHICHEVER IS GREATER. PLACE ACP IN 2" MAX LIFTS.

DRAWN AJD	
DIV ROADWAY	
REV	DATE



CITY OF BEND

CITY OF BEND

STANDARD DRAWING

710 NW WALL ST., BEND, OREGON 97701

TRENCH SURFACE RESTORATION

SCALE NTS

DATE 01/31/2022

APPR

STD DWG R-11

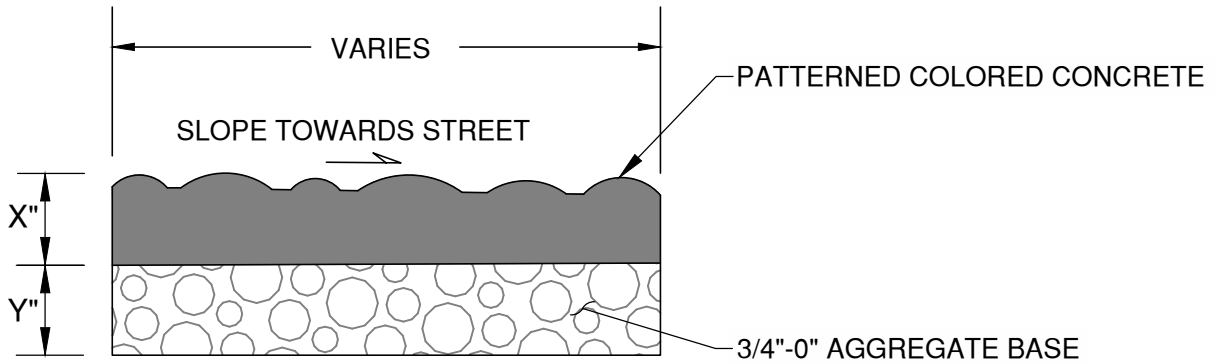

**X DIMENSION:**

- MEDIAN/ALL ADJACENT TO TRAVEL LANE = 6"
- ONLY BACK SIDE OF SIDEWALK OR SEPARATE FROM TRAVEL LANE = 4"
- TRUCK APRON = 9"

**Y DIMENSION:**

- MEDIAN/ALL ADJACENT TO TRAVEL LANE = 6"
- ONLY BACK SIDE OF SIDEWALK OR SEPARATE FROM TRAVEL LANE = 4"
- TRUCK APRON = 6"

**NOTE:**

1. STAMPED CONCRETE SURFACE TEXTURE PATTERN SHALL BE BRICKFORM "FLAGSTONE" TM-700) WITH SAWCUT GROOVE JOINTS 1/3 CONCRETE DEPTH.
2. GLAZE AND SEAL PER MANUFACTURERS SPECS.
3. INTEGRAL COLOR: DAVIS SPANISH GOLD (3 LBS. #5084)
4. RELEASE COLOR: DAVIS DARK GREY (#860)

DRAWN AJD	 <b>CITY OF BEND</b>	<b>CITY OF BEND</b> STANDARD DRAWING 710 NW WALL ST., BEND, OREGON 97701	SCALE NTS
DIV ROADWAY			DATE 01/31/2022
REV DATE			APPR
		<b>PATTERNED COLORED CONCRETE DETAIL</b>	STD DWG R-24

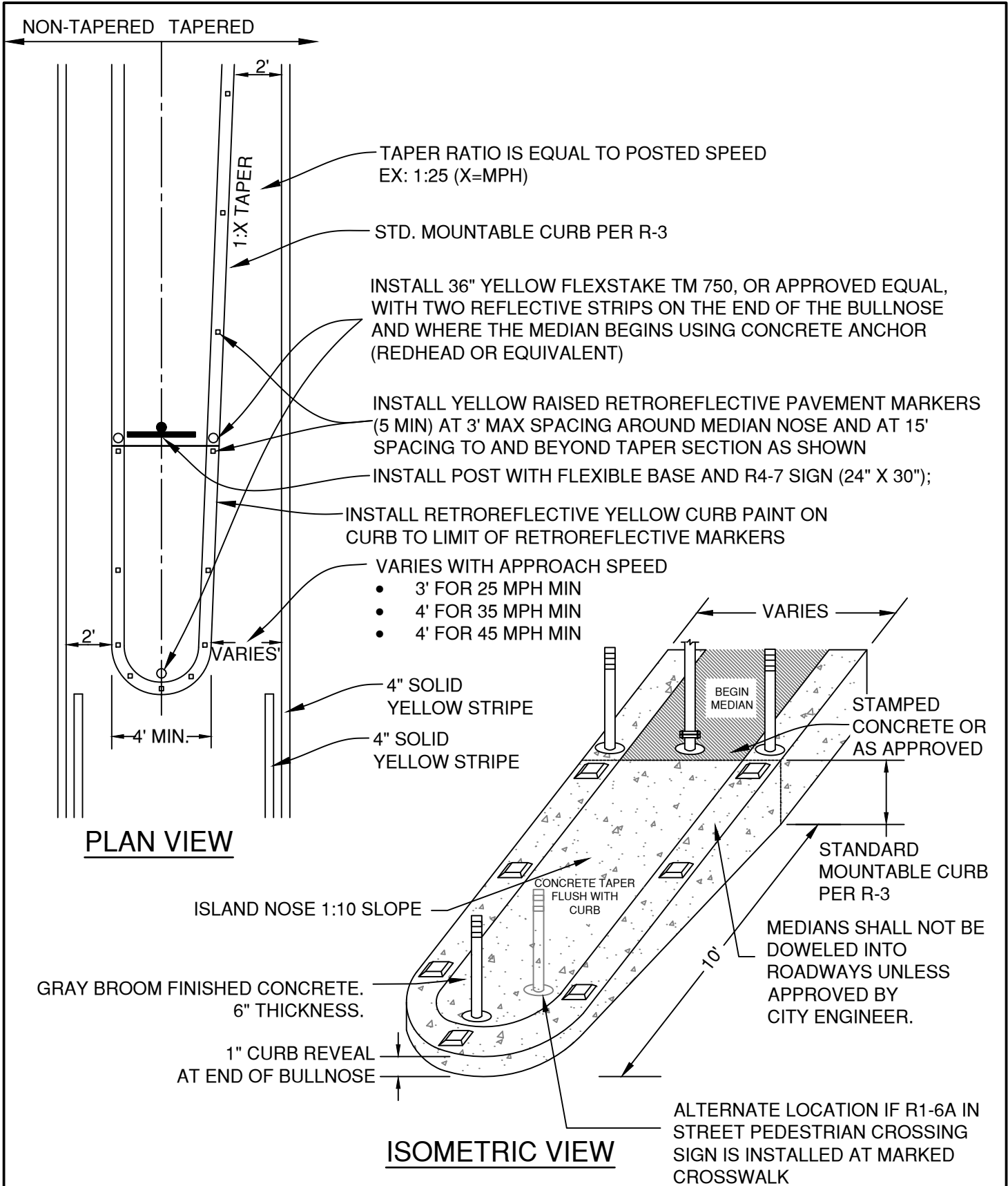

DRAWN ARI	
DIV ROADWAY	
REV	DATE



**CITY OF BEND**  
STANDARD DRAWING  
710 NW WALL ST., BEND, OREGON 97701

**MEDIAN / ISLAND END DETAIL**

SCALE NTS
DATE 04/16/2026
APPR
STD DWG R-25

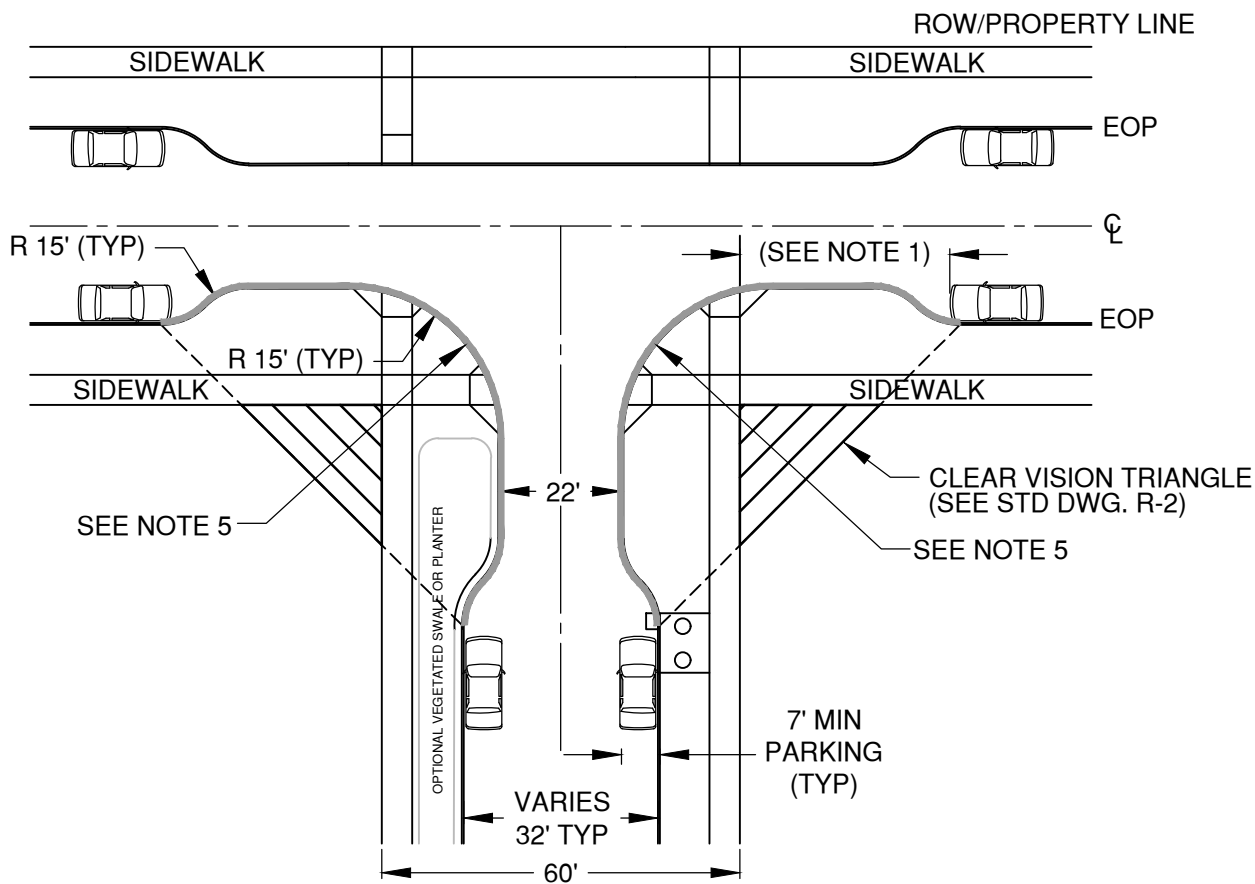

**NOTES:**

1. NO PARKING WITHIN THE CLEAR VISION OR 20 FEET OF THE INTERSECTION, WHICHEVER IS GREATER.
2. AS REQUIRED BY THE CITY ENGINEER, INSTALL YELLOW 36" TALL YELLOW SURFACE MOUNTED TUBULAR MARKERS, PER SPECIFICATION SECTION 00856 FOR PLOW SIGNAGE AT CURB EXTENSIONS.
3. USE LOW GROWING VEGETATION FOR BIORETENTION SWALES/ PLANTERS LOCATED IN CURB EXTENSIONS.
4. CURB RETURNS TO BE CONSTRUCTED PER DESIGN STANDARD.
5. YELLOW CURB PAINT ON RETURNS IS REQUIRED IN COMMERCIAL AND HIGH DENSITY RESIDENTIAL AREAS

DRAWN AJD	
DIV ROADWAY	
REV	DATE



**CITY OF BEND**

**CITY OF BEND**

STANDARD DRAWING

710 NW WALL ST., BEND, OREGON 97701

**LOCAL STREET CURB EXTENSIONS**

SCALE NTS

DATE 01/31/2022

APPR

STD DWG R-26

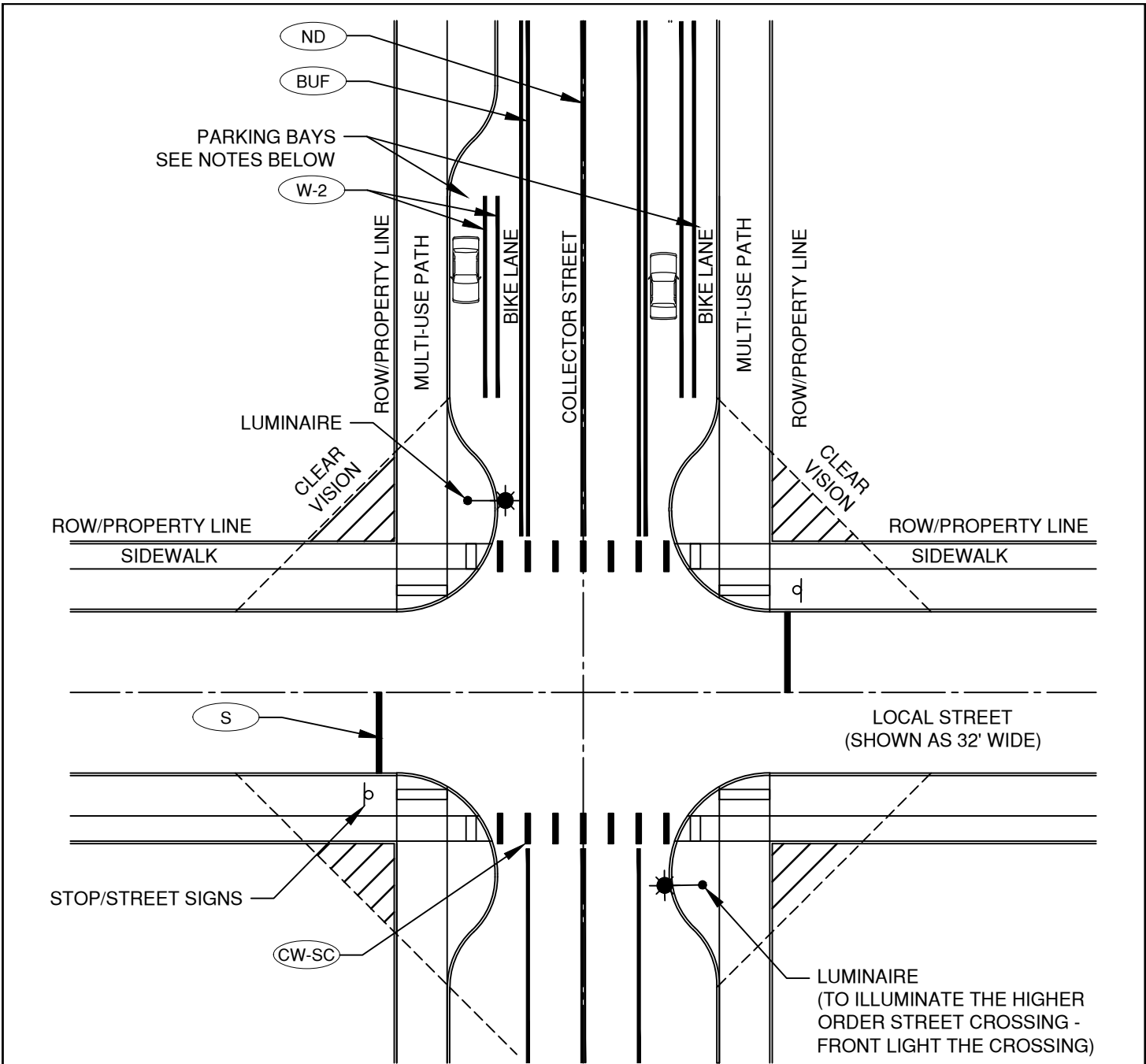

**NOTES:**

1. PARKING BAYS SHALL BE DESIGNED OUTSIDE THE CLEAR VISION OF THE INTERSECTION. PARKING WILL BE PERMITTED IF CLEAR VISION AND SIGHT DISTANCE AS ANALYZED AS SAFE BY A PROFESSIONAL ENGINEER.
2. PARKING BAYS ON COLLECTORS ARE PERMITTED AS DIRECTED BY THE DEVELOPMENT CODE.
3. NO MORE THAN 10 PARKING BAYS WILL BE PERMITTED TOGETHER. TERMINATION OF BAYS WILL BE FOR VEGETATION PLANTING, UTILITY INSTALLATION (FRANCHISE UTILITY VAULTS, STORM FACILITIES, ETC).
4. PARKING IS NOT PERMITTED WITHIN THE INTERSECTION'S CLEAR VISION AND SIGHT DISTANCE AS DETERMINED BY AASHTO REQUIREMENTS AND ENGINEER REVIEW.
5. USE PARKING SEPARATED BIKE LANE WHERE PARKING BAYS ARE LONG/BLOCK LENGTH AND ADEQUATE EXIT/ENTER SIGHT DISTANCE CAN BE PROVIDED.

DRAWN	AJD
DIV	ROADWAY
REV	DATE



**CITY OF BEND**

**CITY OF BEND**

STANDARD DRAWING

710 NW WALL ST., BEND, OREGON 97701

**COLLECTOR / LOCAL INTERSECTION**

SCALE NTS

DATE 11/01/2024

APPR

STD DWG R-27

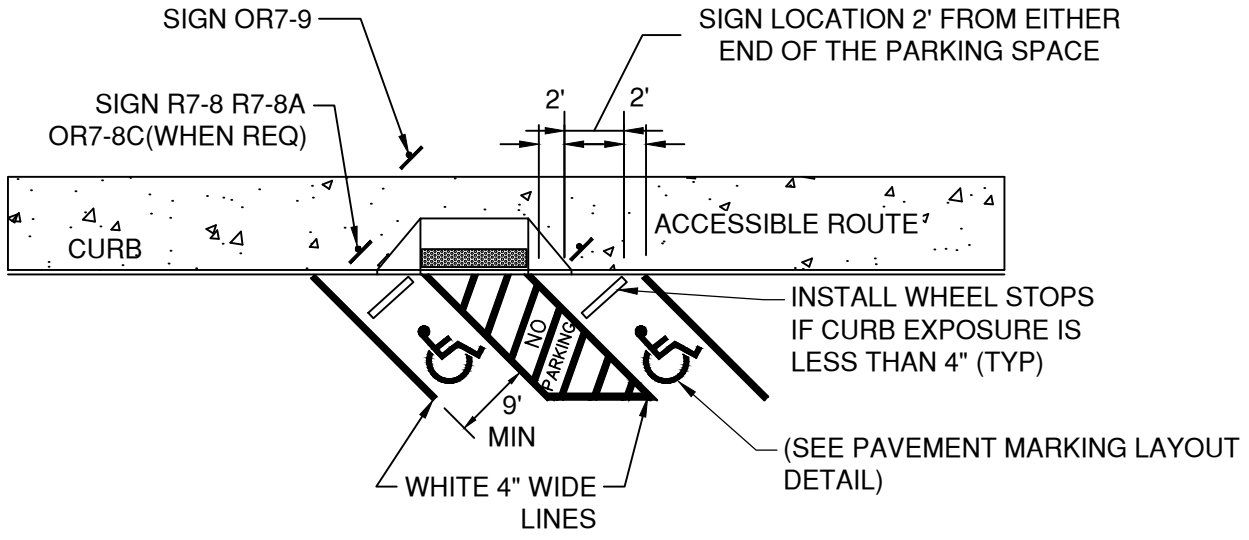

**ANGLED PARKING PLAN**

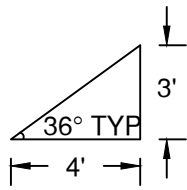

**ACCESS AISLE ANGLE LAYOUT**

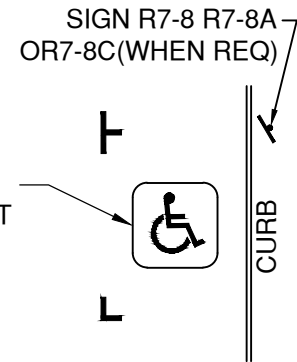

**PARALLEL PARKING PLAN**

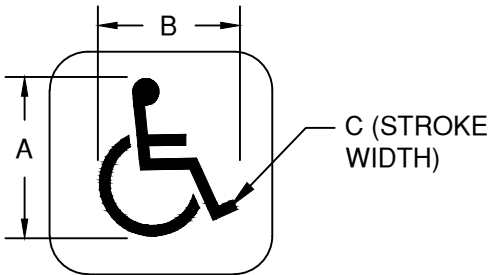

LEGEND	DIMENSIONS (INCHES)		
	A	B	C
MINIMUM	28	24	3
STANDARD	41	36	4

**PAVEMENT MARKING LAYOUT**

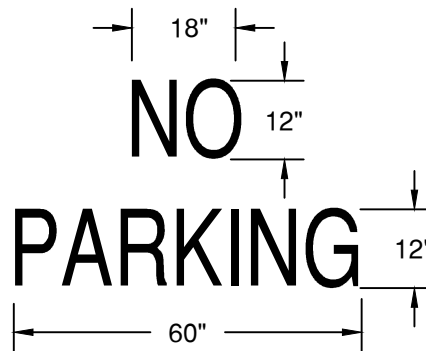

**NOTE:**

1. THIS IS ONE EXAMPLE OF AN ACCESSIBLE PARKING CONFIGURATION. REFER TO ODOT ACCESSIBLE PARKING STANDARDS FOR ADDITIONAL DETAILS AND OTHER CONFIGURATIONS.
2. ALL SIGNS AND PLACEMENT SHALL CONFORM TO ODOT STANDARDS.

DRAWN	AJD
DIV	ROADWAY
REV	DATE



**CITY OF BEND**

**CITY OF BEND**

STANDARD DRAWING

710 NW WALL ST., BEND, OREGON 97701

**ACCESSIBLE PARKING - ANGLE**

SCALE NTS

DATE 01/31/2022

APPR

STD DWG R-29

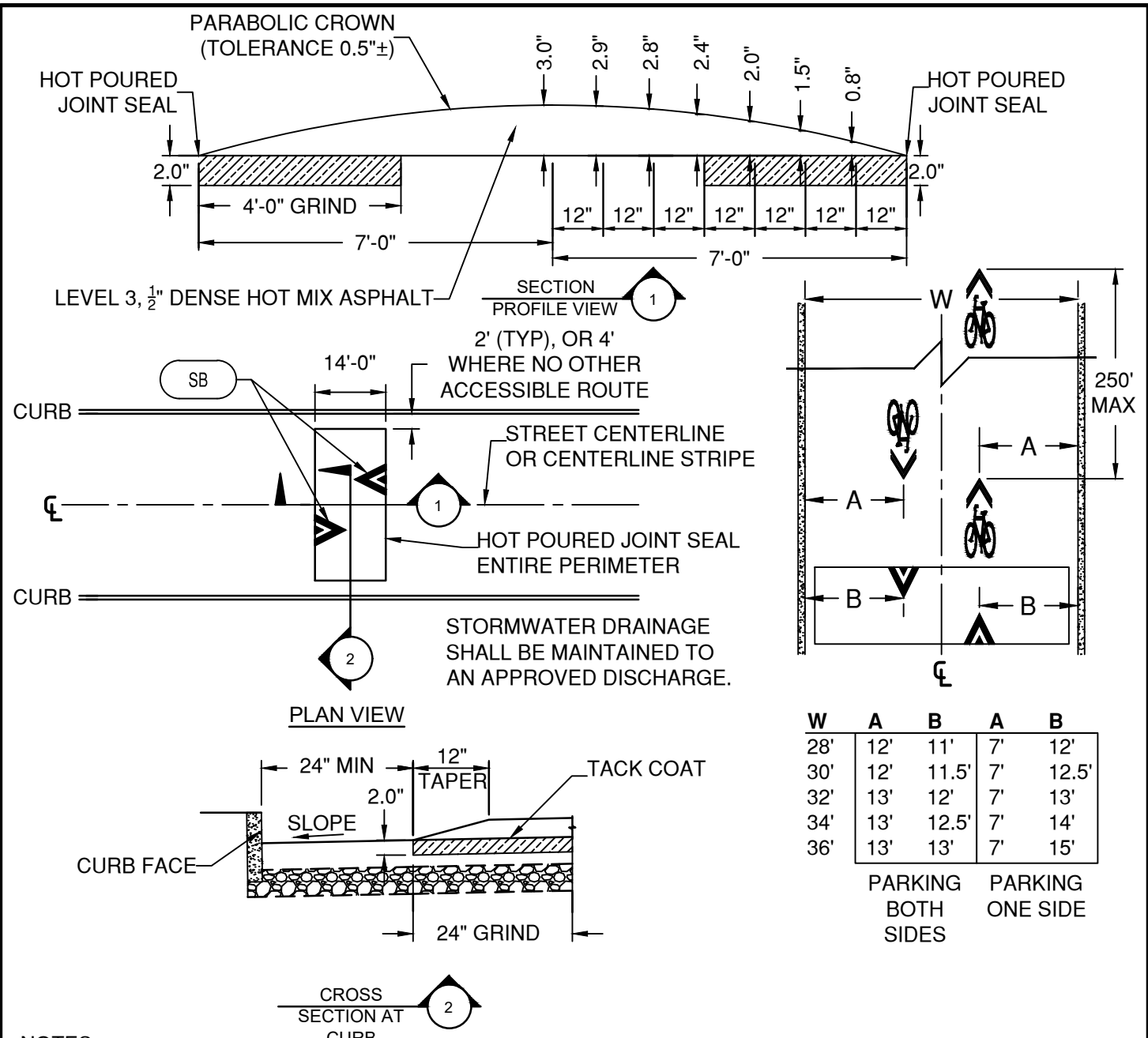

**NOTES:**

1. SPEED HUMPS ARE ONLY PERMITTED IN SELECT LOCATIONS. REFER TO CITY DESIGN STANDARDS.
2. WHERE SPEED HUMP IS A RETRO-FIT TO AN EXISTING ROAD:
  - 2.1. GRIND / KEY-IN PERIMETER TO THE DIMENSIONS SHOWN OR AS DIRECTED BY THE ENGINEER.
  - 2.2. APPLY TACK COAT TO ALL EXISTING SURFACES WHERE SPEED HUMP WILL BE IN CONTACT.
3. HOT POURED JOINT SEAL THE ENTIRE PERIMETER AFTER INSTALLATION.
4. ALL VERTICAL DIMENSIONS HAVE A REQUIRED MAXIMUM TOLERANCE OF +/- 1/4".
5. THE DISTANCE BETWEEN CURB AND EDGE OF THE SPEED HUMP VARIES. SEE ENGINEERED PLANS.
6. PAVEMENT MARKINGS ON SPEED BUMP SHALL BE INSTALLED CONCURRENTLY WITH THE ASPHALT STRUCTURES. PAVEMENT MARKINGS SHALL BE THERMO-PLASTIC.
7. PAVEMENT MARKINGS SHALL BE INSTALLED BEFORE OPENING ANY LANE TO TRAFFIC THAT IS OCCUPIED BY A NEW SPEED BUMP.
8. SPEED HUMPS ARE NOT PERMITTED IN ACCESSIBLE ROUTES OR WHERE IN CONFLICT WITH DRIVEWAYS.

DRAWN AJD	
DIV ROADWAY	
REV	DATE



**CITY OF BEND**  
STANDARD DRAWING  
710 NW WALL ST., BEND, OREGON 97701

**SPEED HUMPS AND SHARROW PLACEMENT**

SCALE NTS
DATE 01/31/2022
APPR
STD DWG R-32

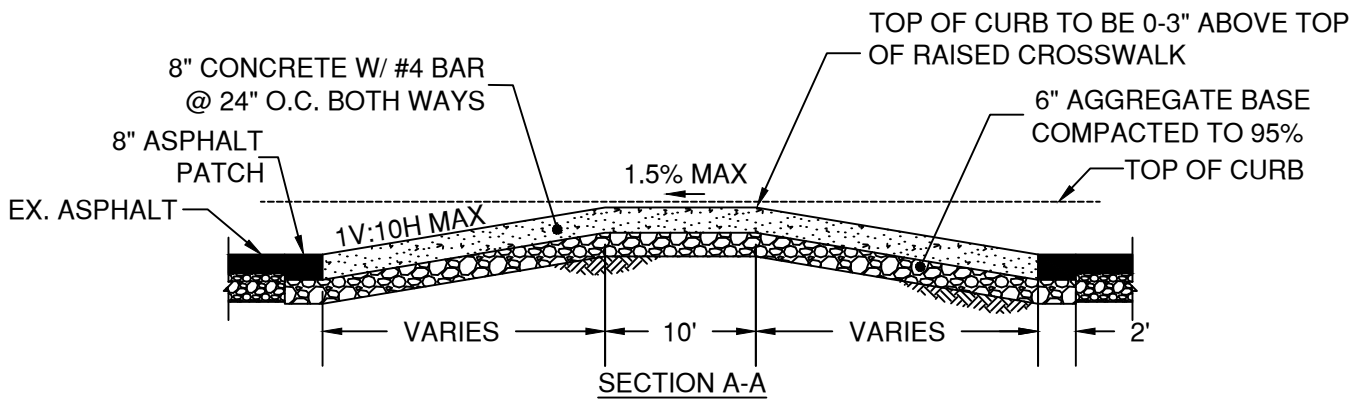
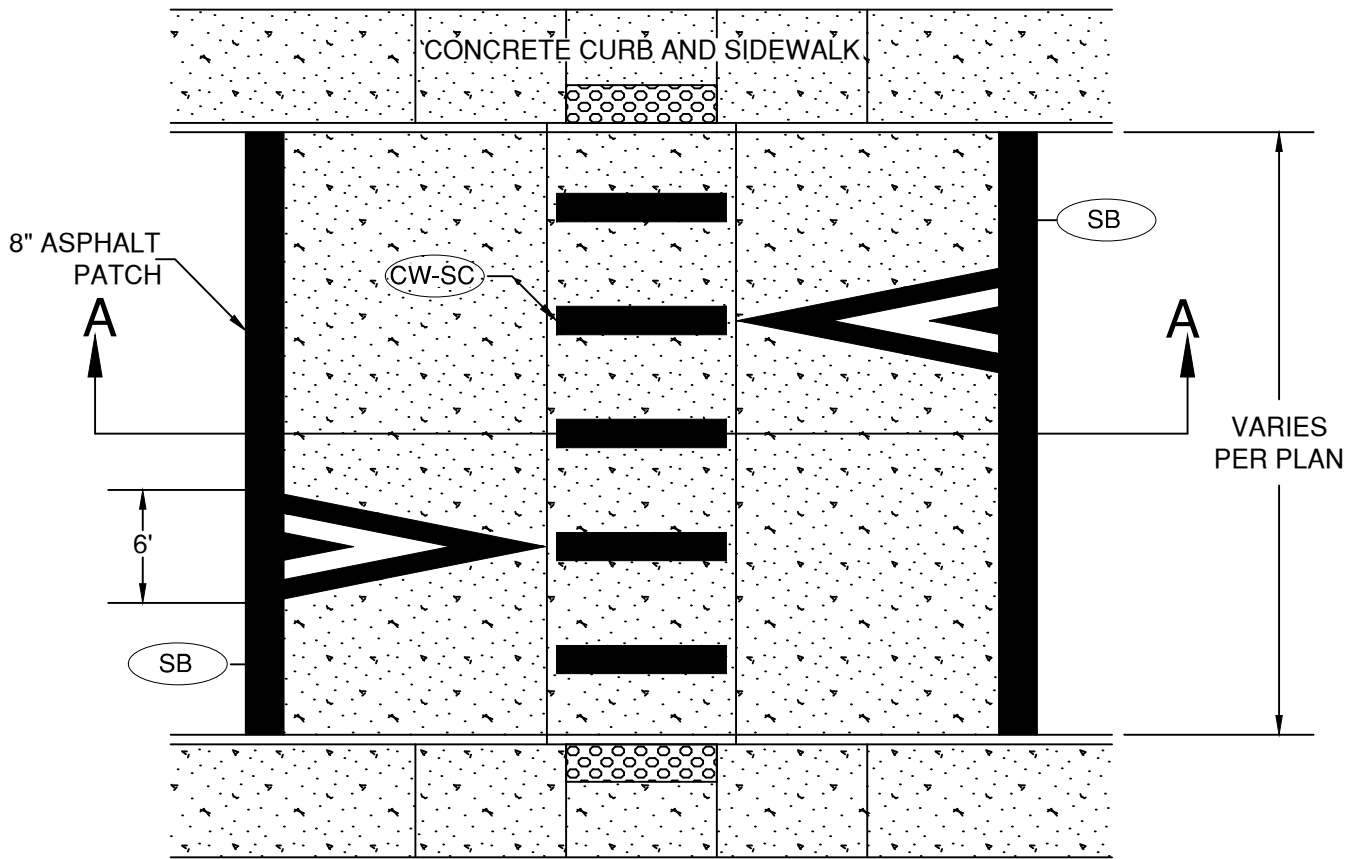

**NOTES:**

1. RAISED CROSSWALKS ARE ONLY PERMITTED IN SELECT LOCATIONS. REFER TO CITY DESIGN STANDARDS.
2. HOT POURED JOINT SEAL THE ENTIRE PERIMETER AFTER INSTALLATION.
3. PAVEMENT MARKINGS ON RAISED CROSSWALKS SHALL BE THERMO-PLASTIC.
4. PAVEMENT MARKINGS SHALL BE INSTALLED BEFORE OPENING ANY LANE TO TRAFFIC THAT IS OCCUPIED BY A NEW SPEED BUMP.

DRAWN AJD	
DIV ROADWAY	
REV	DATE



CITY OF BEND

**CITY OF BEND**  
STANDARD DRAWING

710 NW WALL ST., BEND, OREGON 97701

**RAISED CROSSWALK**

SCALE NTS

DATE 01/31/2022

APPR

STD DWG R-33

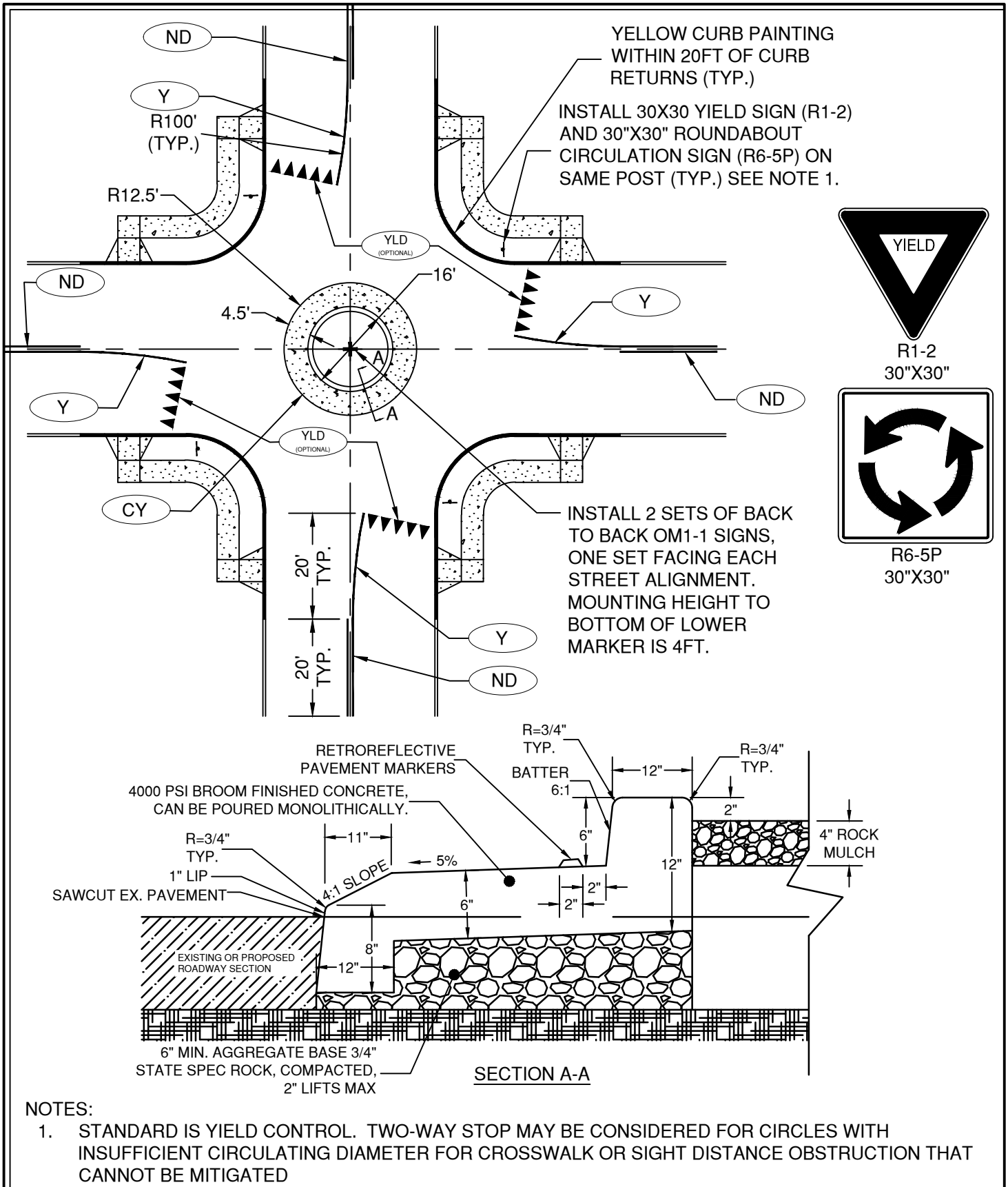

DRAWN AJD	
DIV ROADWAY	
REV	DATE



CITY OF BEND

CITY OF BEND  
STANDARD DRAWING

710 NW WALL ST., BEND, OREGON 97701

TRAFFIC CIRCLE

SCALE NTS

DATE 01/31/2022

APPR

STD DWG R-34

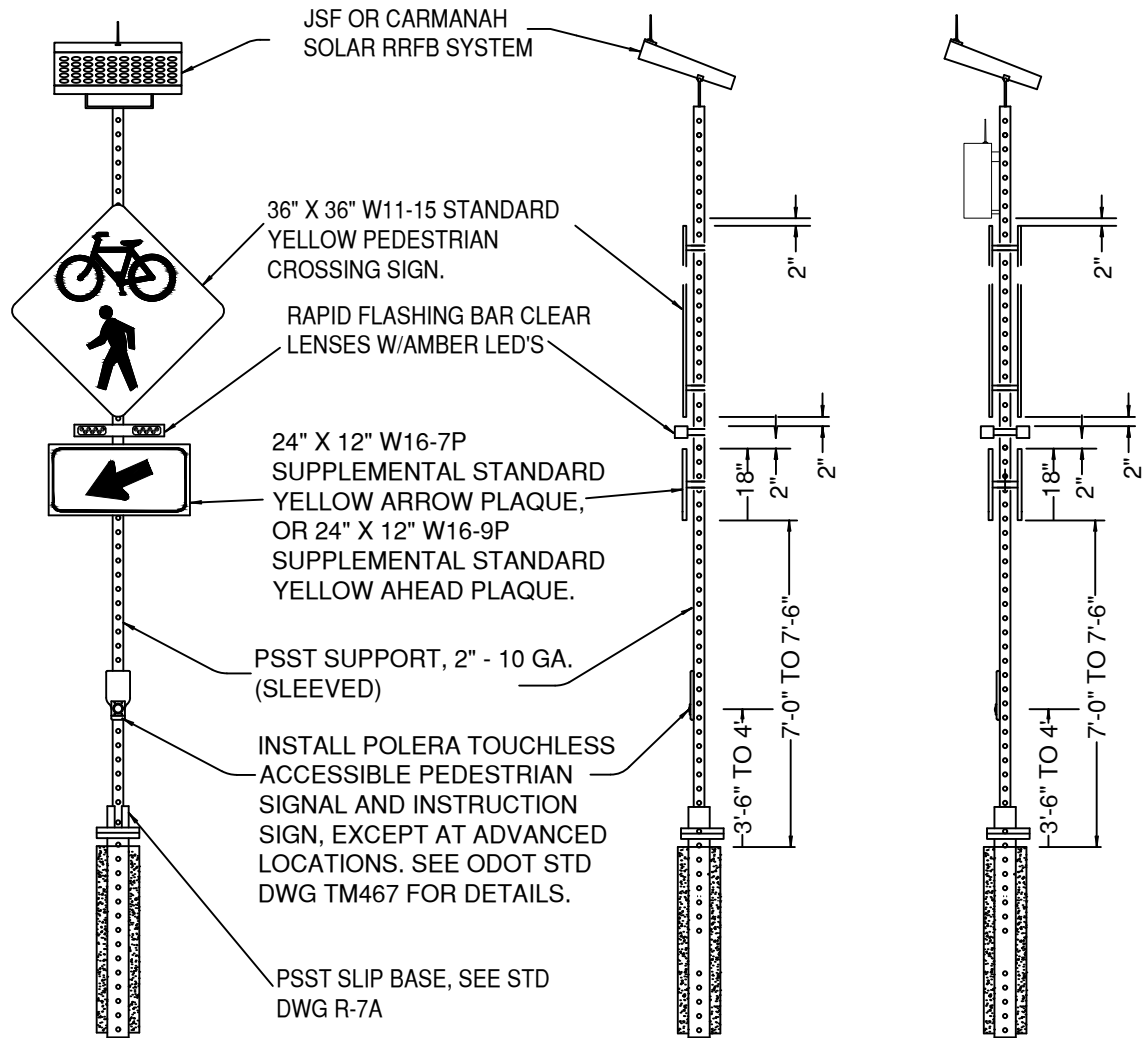

FRONT VIEW

SINGLE SIDED  
SIDE VIEW

TWO SIDED  
SIDE VIEW

RECTANGULAR RAPID FLASHING BEACON SYSTEM  
PSST INSTALLATION

**NOTES:**

1. REMOVE SOLAR EQUIPMENT IF USING COMMERCIAL POWER
2. USE APPLIED INFORMATION AI-500-030 LOW POWER MONITORING DEVICE
3. USE SCHOOL CROSSING (S1-1) FOR DESIGNATED SCHOOL CROSSING
4. USE DOUBLE SIDED SIGNS IN MEDIANS
5. ADD RADIO NETWORK CONTROLLER (APPLIED INFORMATION CONTROLLER GLANCE LOW POWER MONITORING DEVICE) INCLUDING ANY RETROFIT / MOUNTING KIT.

DRAWN ARI	
DIV ROADWAY	
REV	DATE



**CITY OF BEND**  
STANDARD DRAWING

710 NW WALL ST., BEND, OREGON 97701

**RECTANGULAR RAPID FLASHING BEACON**

SCALE NTS

DATE 04/16/2026

APPR

STD DWG R-35A

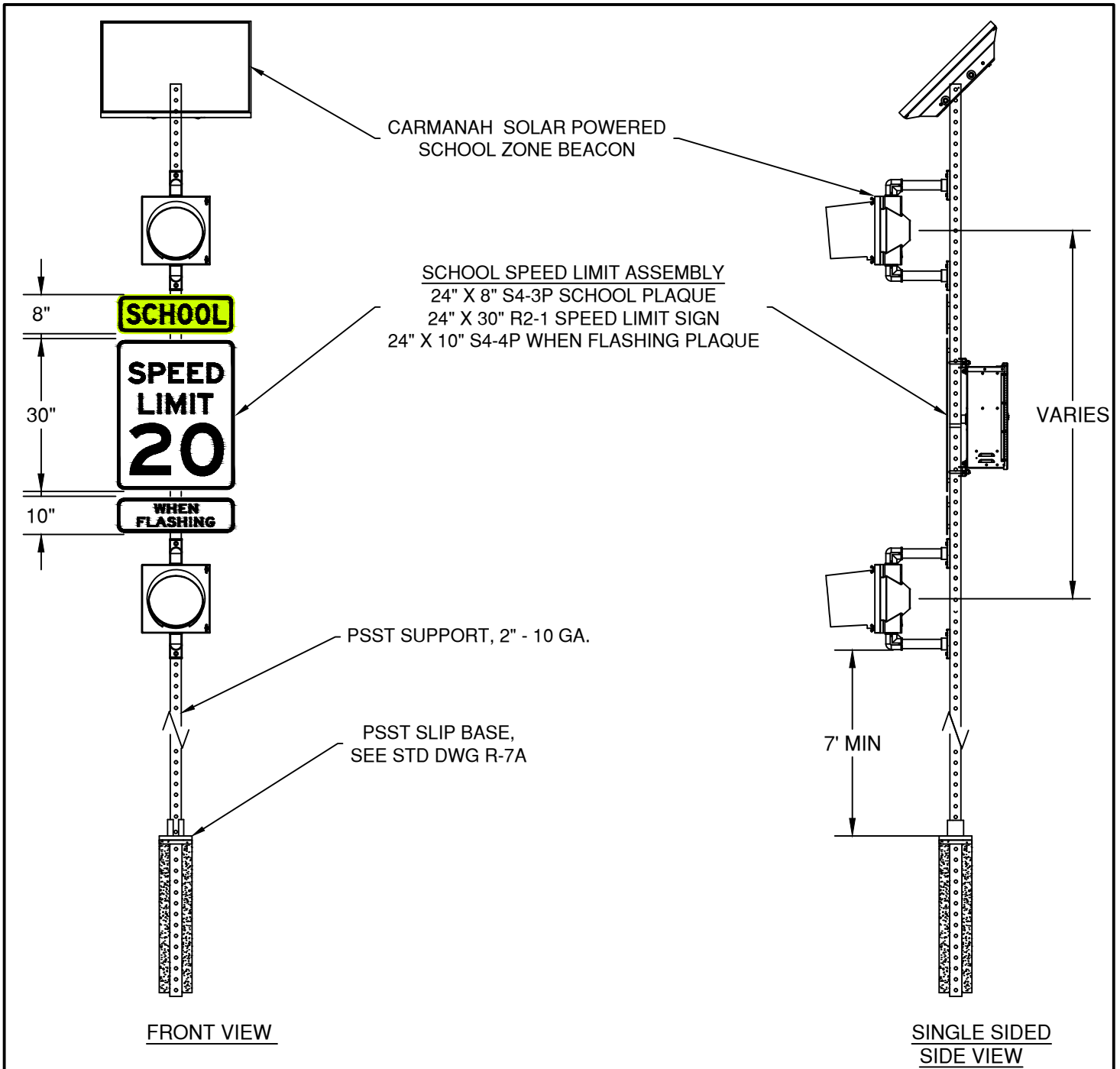

**SOLAR POWER SCHOOL ZONE BEACON  
PSST INSTALLATION**

**NOTES:**

1. REMOVE SOLAR EQUIPMENT IF USING COMMERCIAL POWER
2. ADD RADIO NETWORK CONTROLLER FOR WIRELESS EQUIPMENT IF NEEDED
3. ADD RADIO NETWORK CONTROLLER (APPLIED INFORMATION CONTROLLER GLANCE LOW POWER MONITORING DEVICE) INCLUDING ANY RETROFIT / MOUNTING KIT.

DRAWN AJD	
DIV ROADWAY	
REV	DATE



**CITY OF BEND**  
 STANDARD DRAWING  
 710 NW WALL ST., BEND, OREGON 97701  
**FLASHING SCHOOL ZONE BEACON**

SCALE NTS
DATE 11/01/2024
APPR
STD DWG R-35B

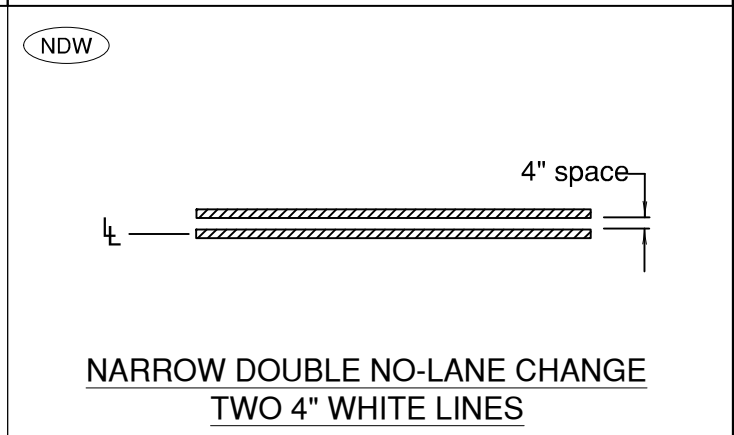
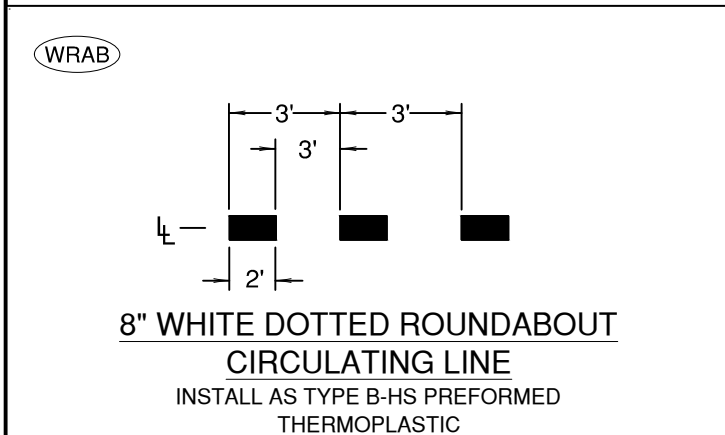
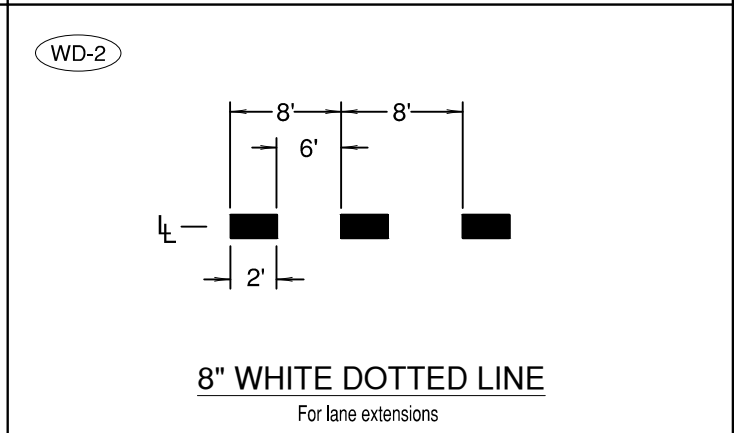
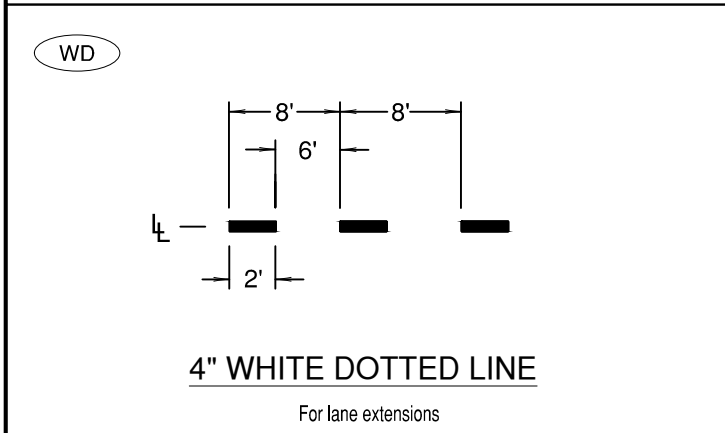
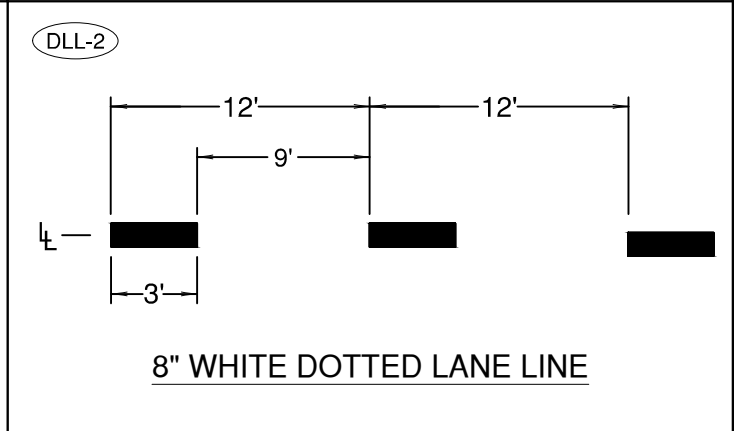
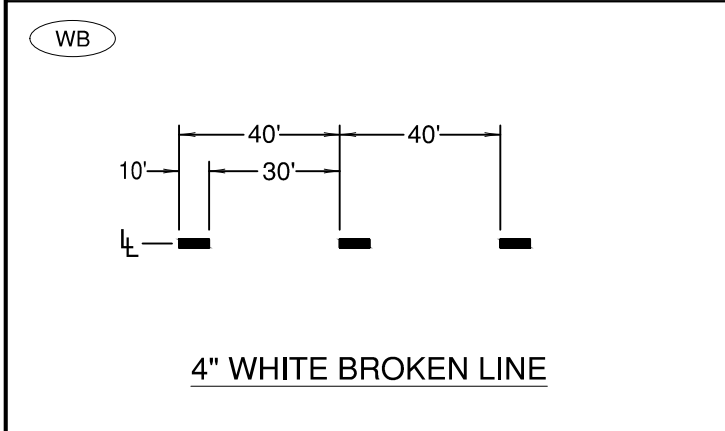
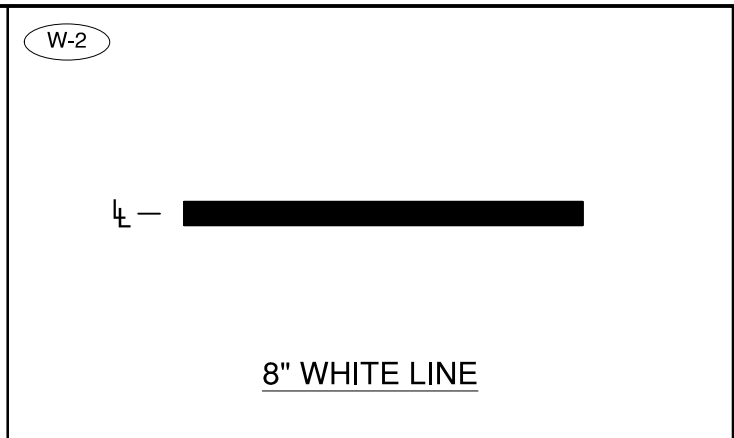
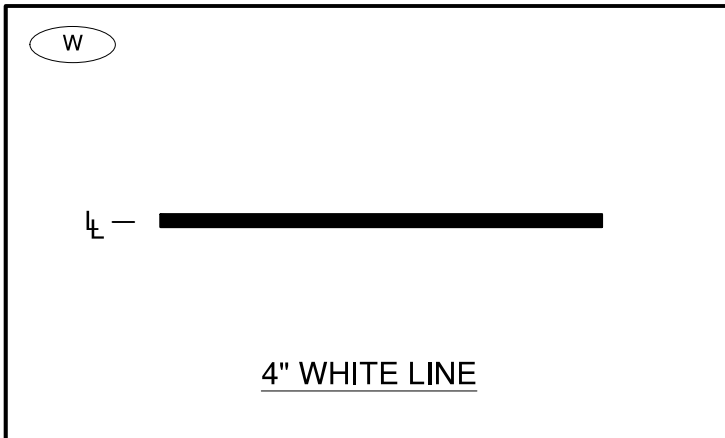

DRAWN AJD	
DIV ROADWAY	
REV	DATE



CITY OF BEND  
STANDARD DRAWING  
710 NW WALL ST., BEND, OREGON 97701

PAVEMENT MARKINGS - WHITE

SCALE NTS
DATE 01/31/2022
APPR
STD DWG R-40

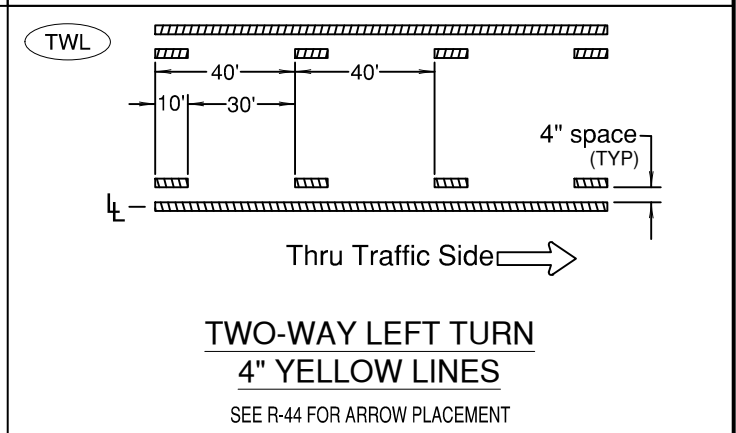
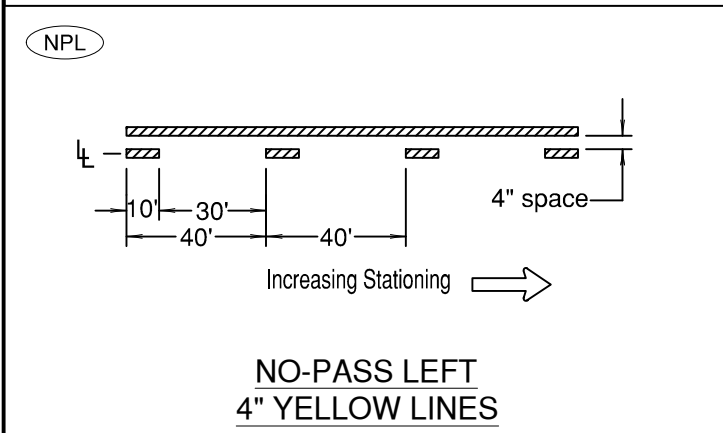
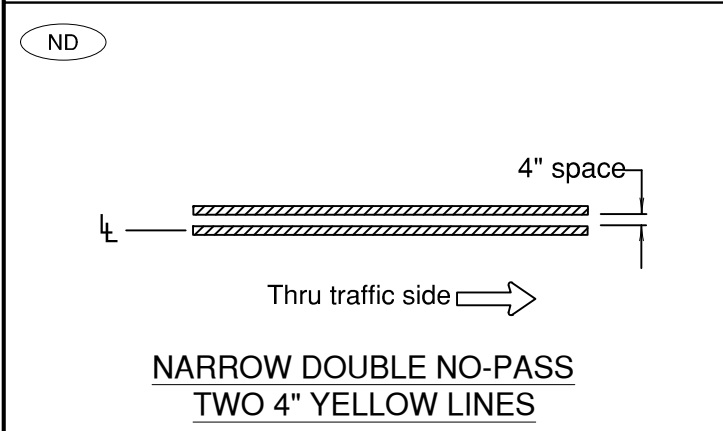
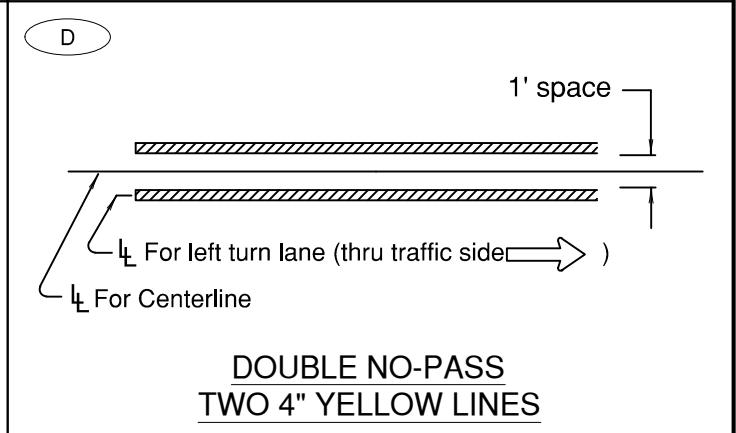
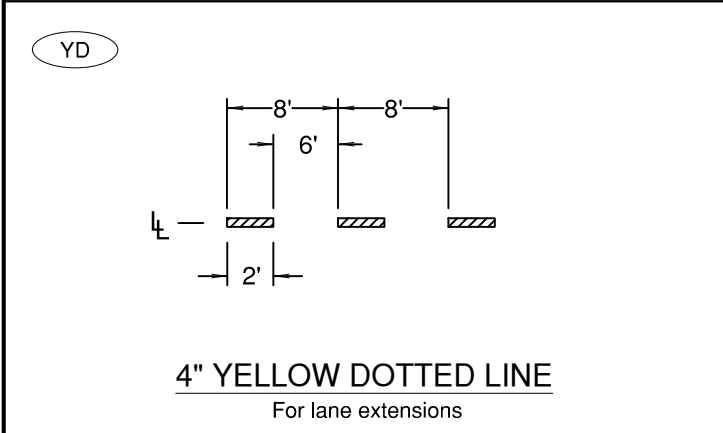
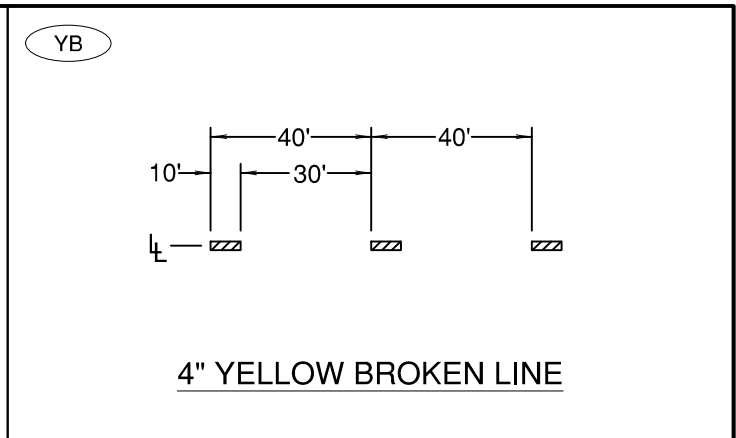
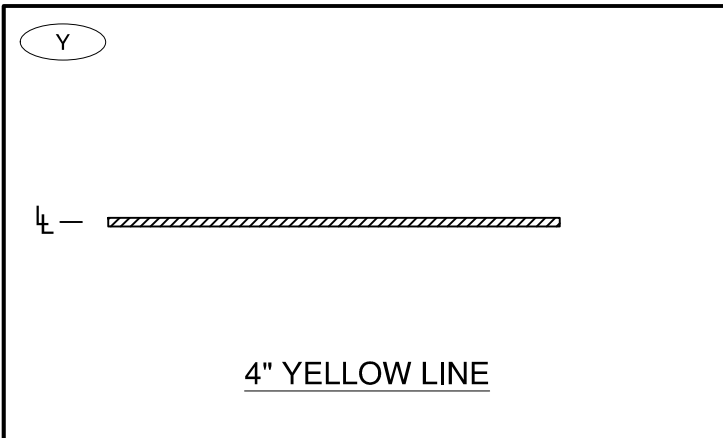

DRAWN AJD	
DIV ROADWAY	
REV	DATE



**CITY OF BEND**  
 STANDARD DRAWING  
 710 NW WALL ST., BEND, OREGON 97701  
**PAVEMENT MARKINGS - YELLOW**

SCALE NTS
DATE 01/31/2022
APPR
STD DWG R-41

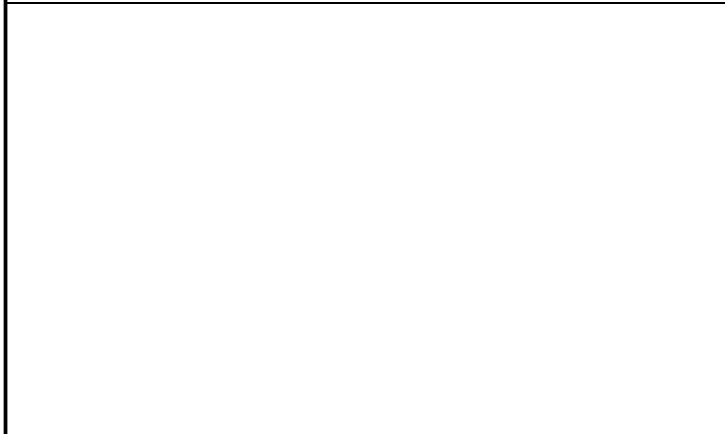
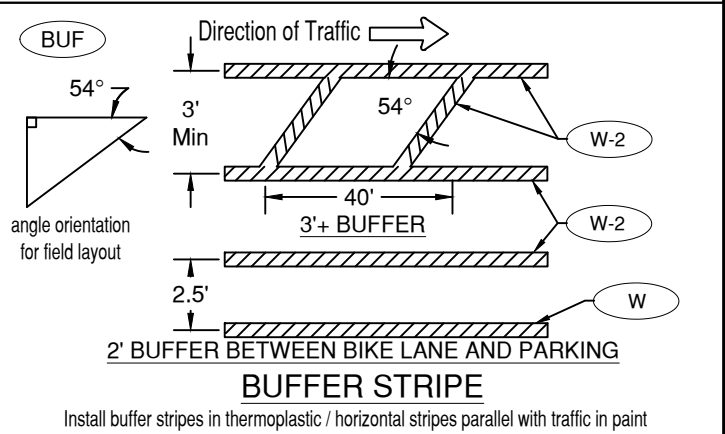
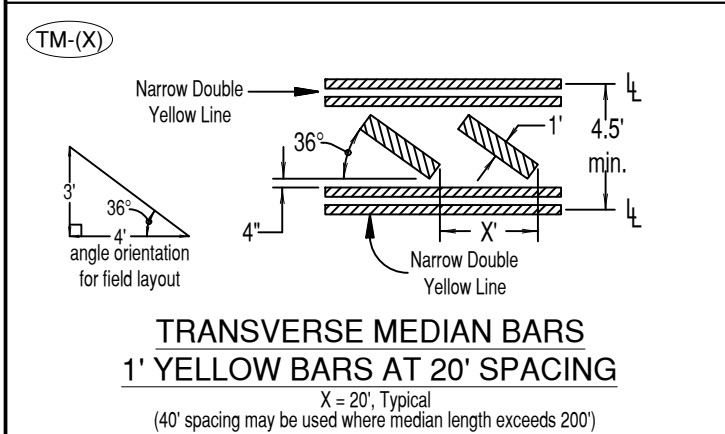
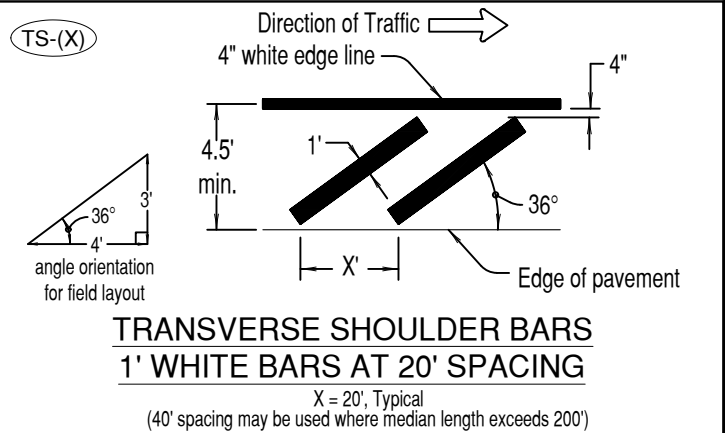
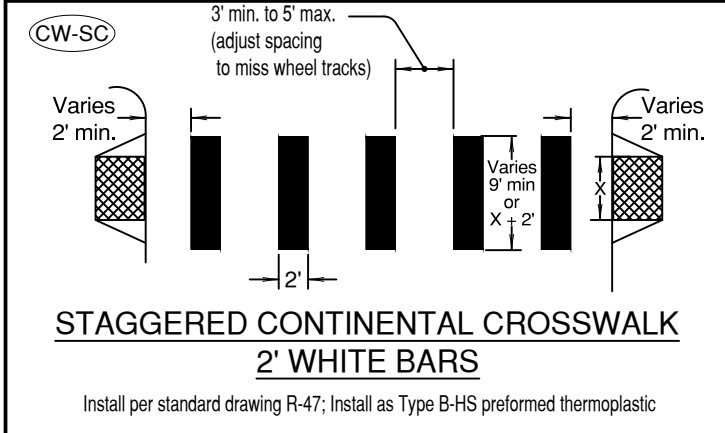
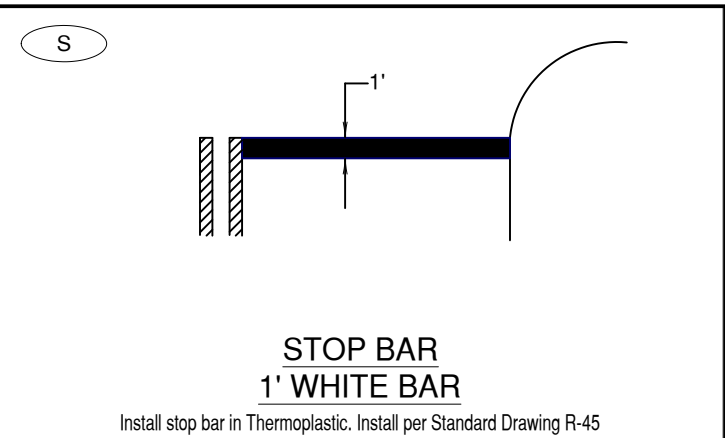
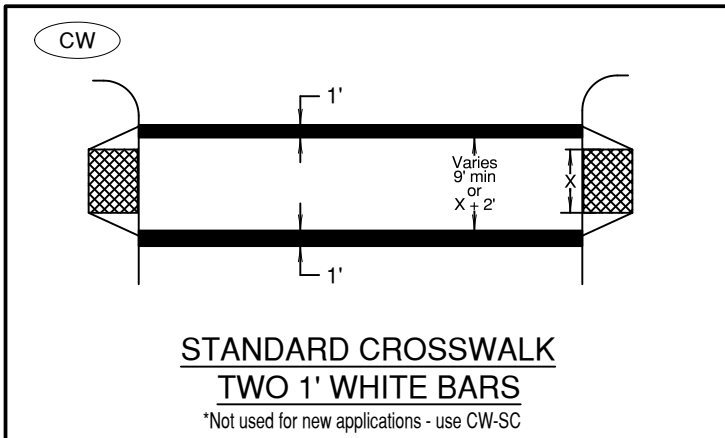

DRAWN AJD	
DIV ROADWAY	
REV	DATE



**CITY OF BEND**  
STANDARD DRAWING  
710 NW WALL ST., BEND, OREGON 97701

**PAVEMENT MARKINGS**

SCALE NTS
DATE 04/16/2026
APPR
STD DWG R-42A

ON

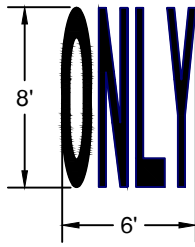

**ONLY (white)**

Center marking within lane width  
Install in Type B - HS Preformed Thermoplastic  
For letter proportion details, see current version of FHWA Standard Highway Signs

SCH

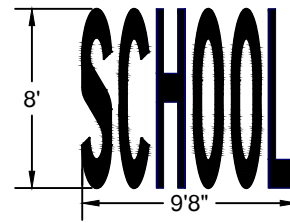

\*For travel lanes <11' width,  
use 6' tall x 8' wide stencil

**SCHOOL (white)\***

Center marking within lane width  
Install in Type B - HS Preformed Thermoplastic  
For letter proportion details, see current version of FHWA Standard Highway Signs  
Install at school speed zone sign on arterial and collector roads

E-SA

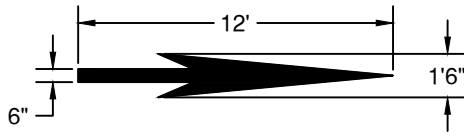

**ELONGATED STRAIGHT ARROW (white)**

For arrow proportion details, see current version of FHWA Standard Highway Signs  
Install in Type B - HS Preformed Thermoplastic  
Center marking within lane width

E-LA

E-RA

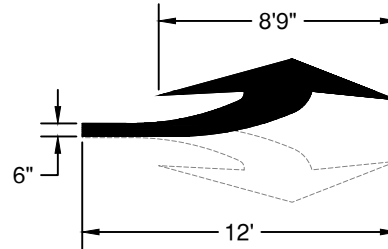

**ELONGATED TURN ARROW (white)**

For arrow proportion details, see current version of FHWA Standard Highway Signs  
Install in Type B - HS Preformed Thermoplastic  
Center marking within lane width  
Use E-LA for Left Turn and E-RA for right turn.

E-LSA

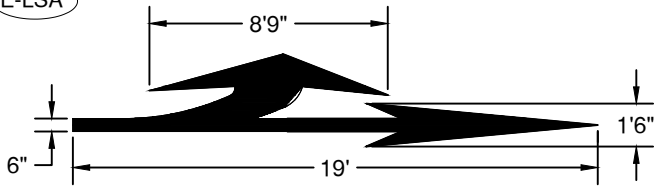

**ELONGATED LEFT TURN STRAIGHT ARROW (white)**

For arrow proportion details, see current version of FHWA Standard Highway Signs  
Install in Type B - HS Preformed Thermoplastic  
Center marking within lane width

E-RSA

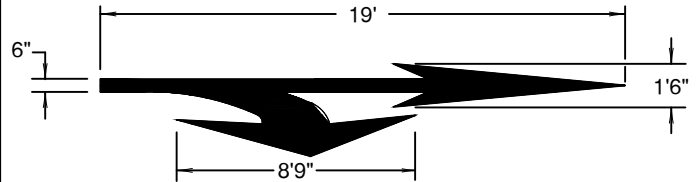

**ELONGATED RIGHT TURN STRAIGHT ARROW (white)**

For arrow proportion details, see current version of FHWA Standard Highway Signs  
Install in Type B - HS Preformed Thermoplastic  
Center marking within lane width

P

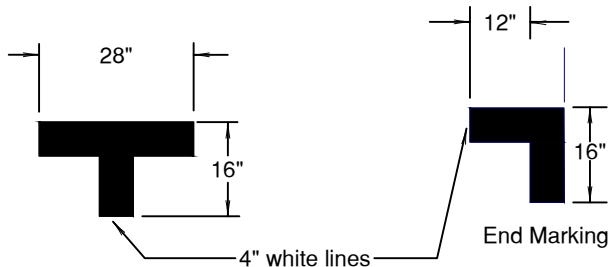

**ON-STREET PARKING DETAIL (white)**

SB

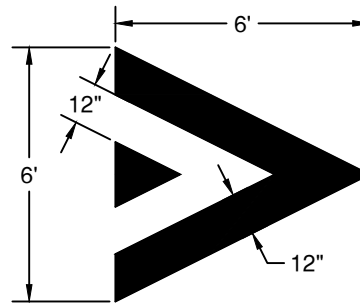

**SPEED BUMP MARKING (WHITE)**

Install in Type B - HS Preformed Thermoplastic  
Center marking within lane width

DRAWN ARI  
DIV ROADWAY  
REV DATE



**CITY OF BEND**

STANDARD DRAWING

710 NW WALL ST., BEND, OREGON 97701

**PAVEMENT MARKINGS**

SCALE NTS

DATE 04/16/2026

APPR

STD DWG R-42B

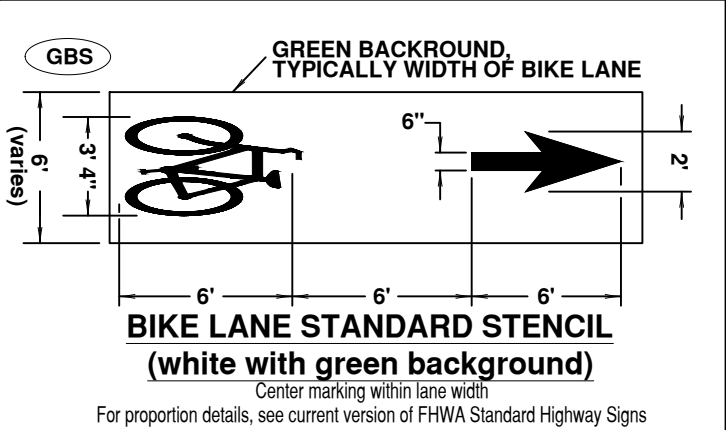
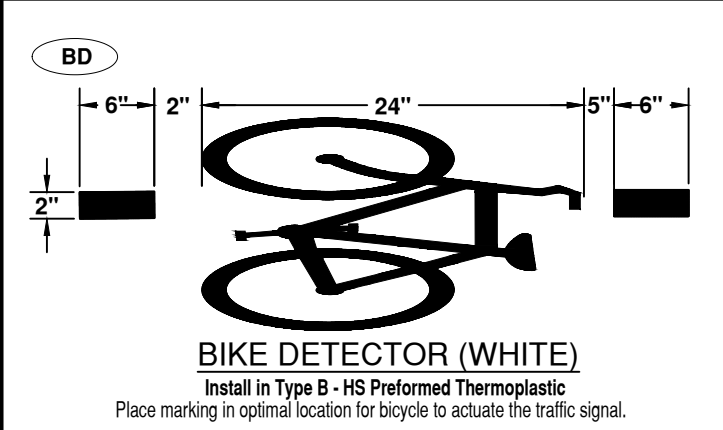
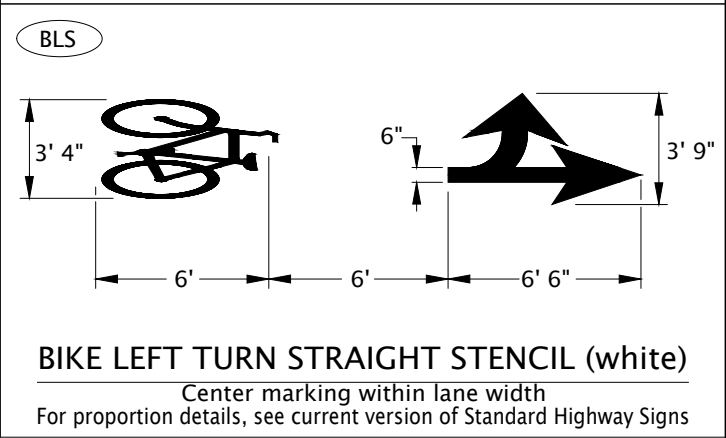
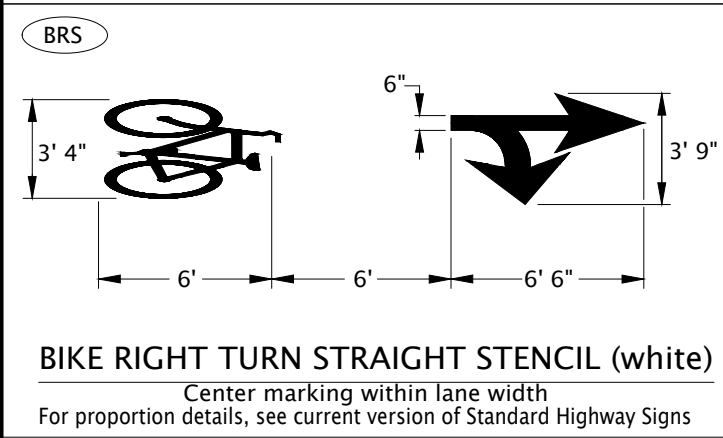
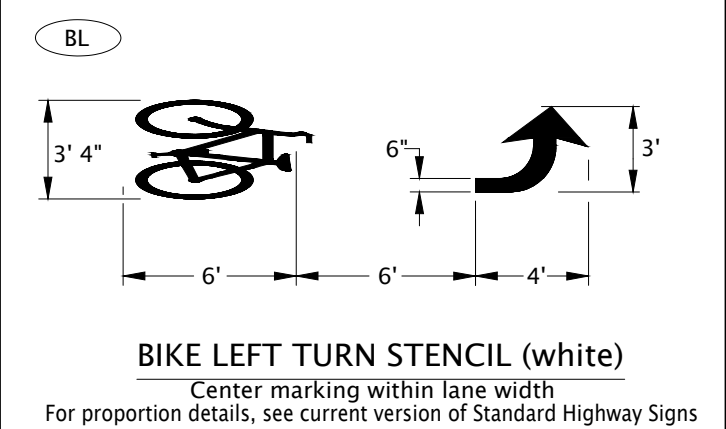
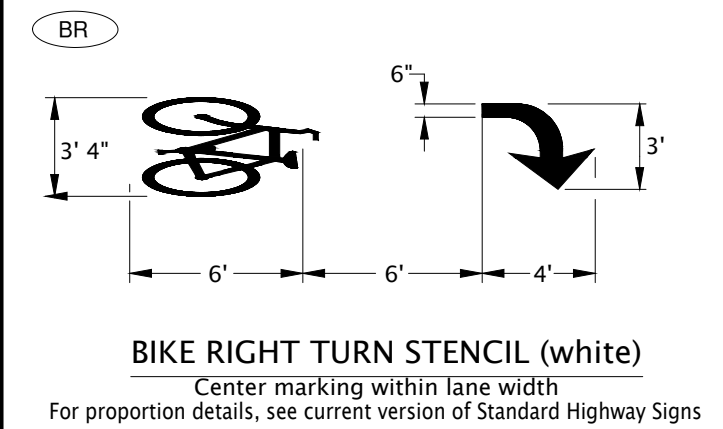
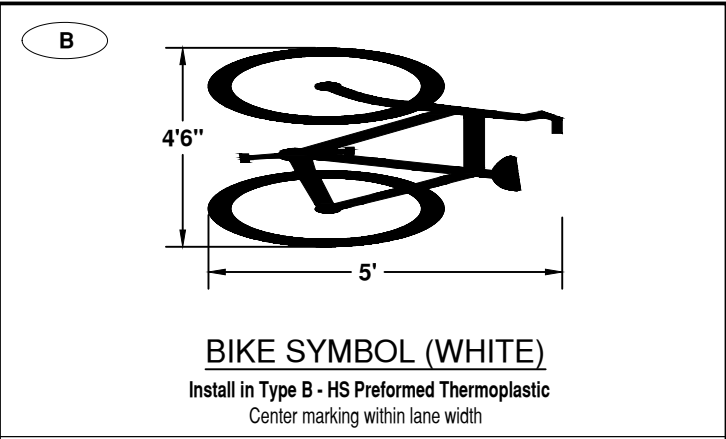
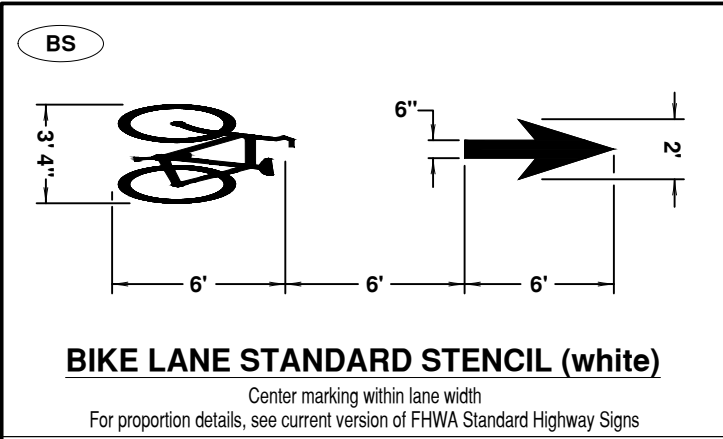

DRAWN <b>ARI</b>	
DIV <b>ROADWAY</b>	
REV	DATE



**CITY OF BEND**  
STANDARD DRAWING  
710 NW WALL ST., BEND, OREGON 97701

**PAVEMENT MARKINGS - BIKE**

SCALE <b>NTS</b>
DATE <b>04/16/2026</b>
APPR
STD DWG <b>R-43</b>

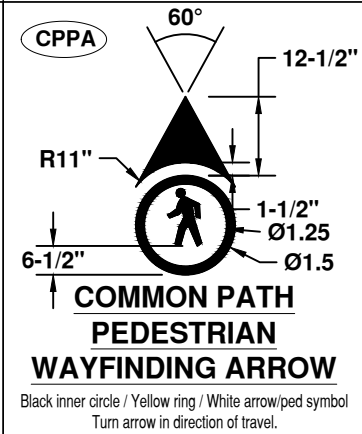
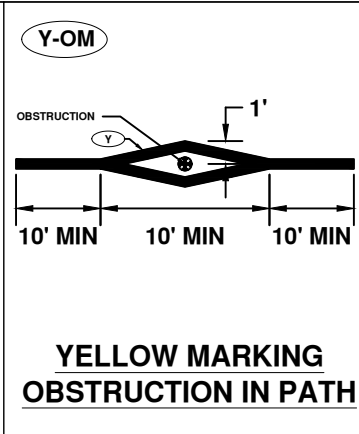
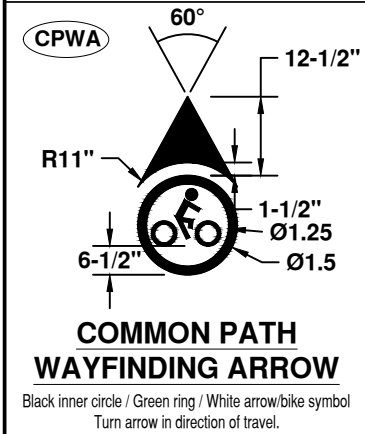
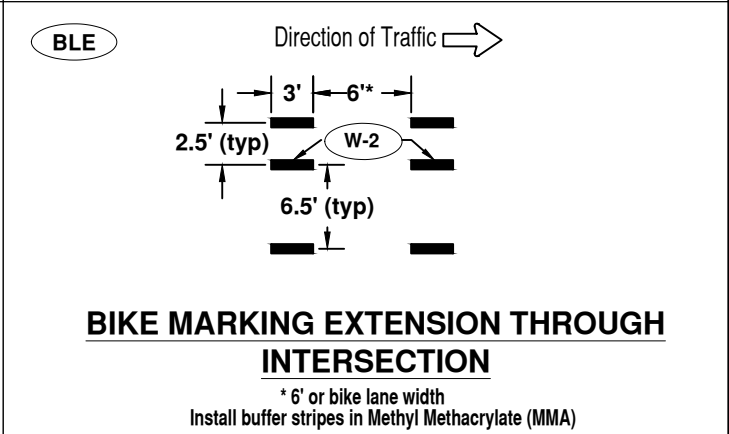
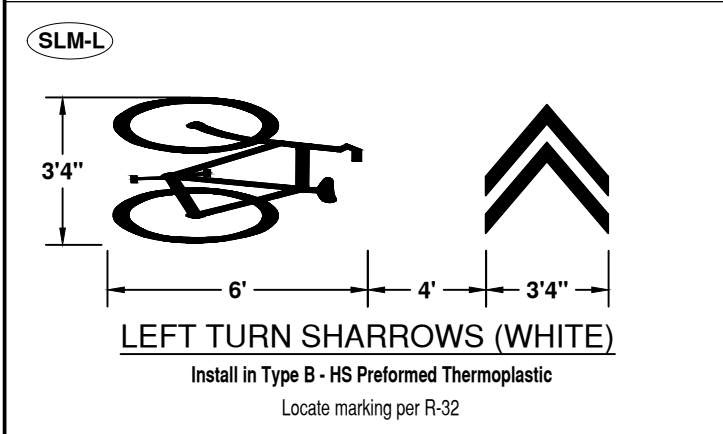
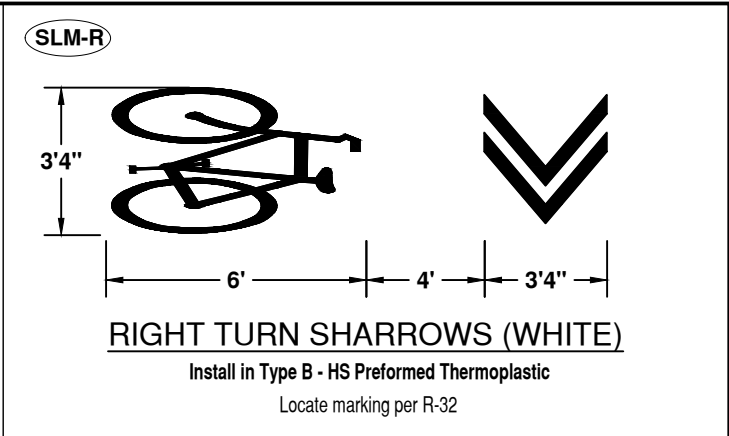
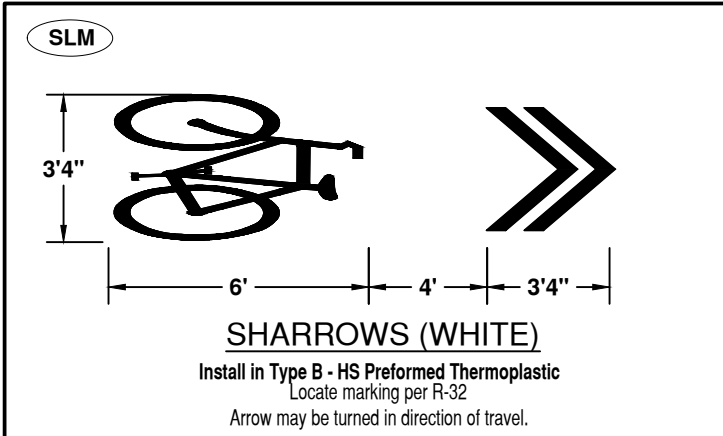

DRAWN <b>ARI</b>	
DIV <b>ROADWAY</b>	
REV	DATE



**CITY OF BEND**  
 STANDARD DRAWING  
 710 NW WALL ST., BEND, OREGON 97701

**PAVEMENT MARKINGS - BIKE**

SCALE <b>NTS</b>
DATE <b>04/16/2026</b>
APPR
STD DWG <b>R-43A</b>

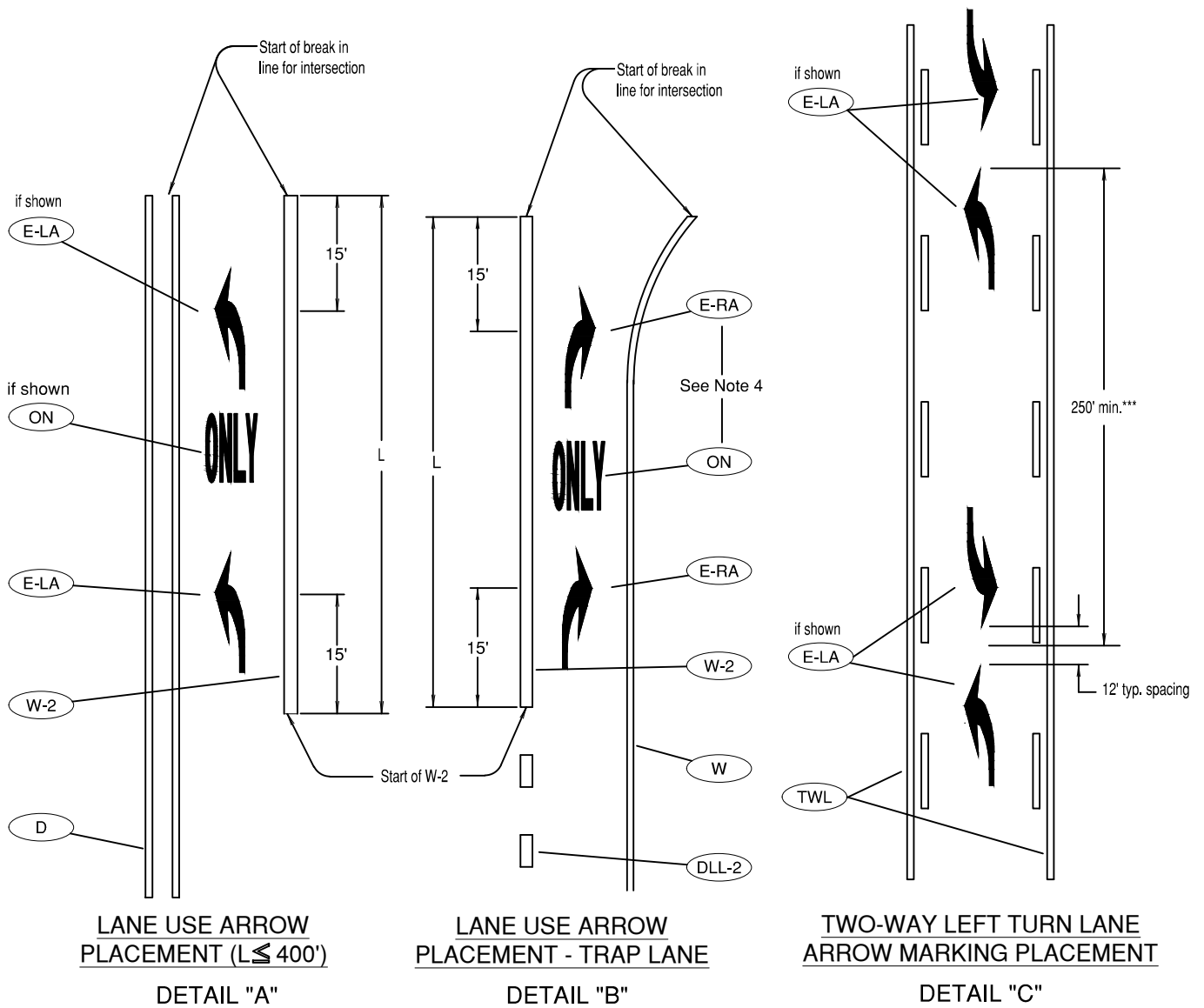

General Notes:

- Center pavement marking legends within the lane.
- Placement of lane use arrows with respect to the 8" wide white line (W-2) channelization shown in details "A", "B" and "C" apply to both left and right turn lanes.
- When used for a short turn lane (<40'), the 2nd (downstream) arrow may be omitted.
- An ONLY symbol is only required where a through lane approaching an intersection becomes a mandatory turn lane.

\*\* When L is greater than 200', install 3rd lane use arrow at the midpoint of the turn lane.

To be accompanied by Standard Dwg. Nos. R-40 thru R-43

DRAWN AJD  
DIV ROADWAY  
REV DATE



CITY OF BEND

CITY OF BEND  
STANDARD DRAWING

710 NW WALL ST., BEND, OREGON 97701

TURN LANE MARKING LAYOUT

SCALE NTS

DATE 01/31/2022

APPR

STD DWG R-44

GRN

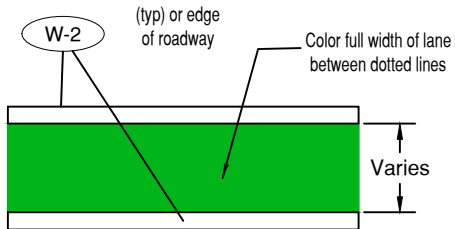

**GREEN SUPPLEMENTED BICYCLE LANE  
SOLID LANE**

BLE-G

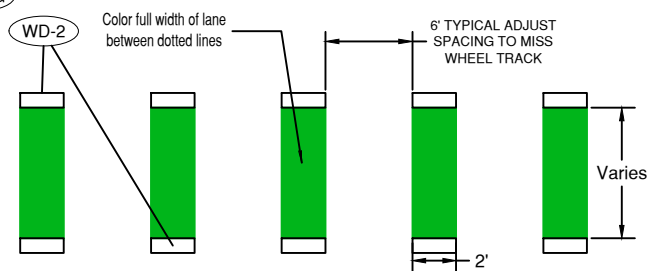

**GREEN SUPPLEMENTED BICYCLE LANE  
DOTTED LINE EXTENSION**

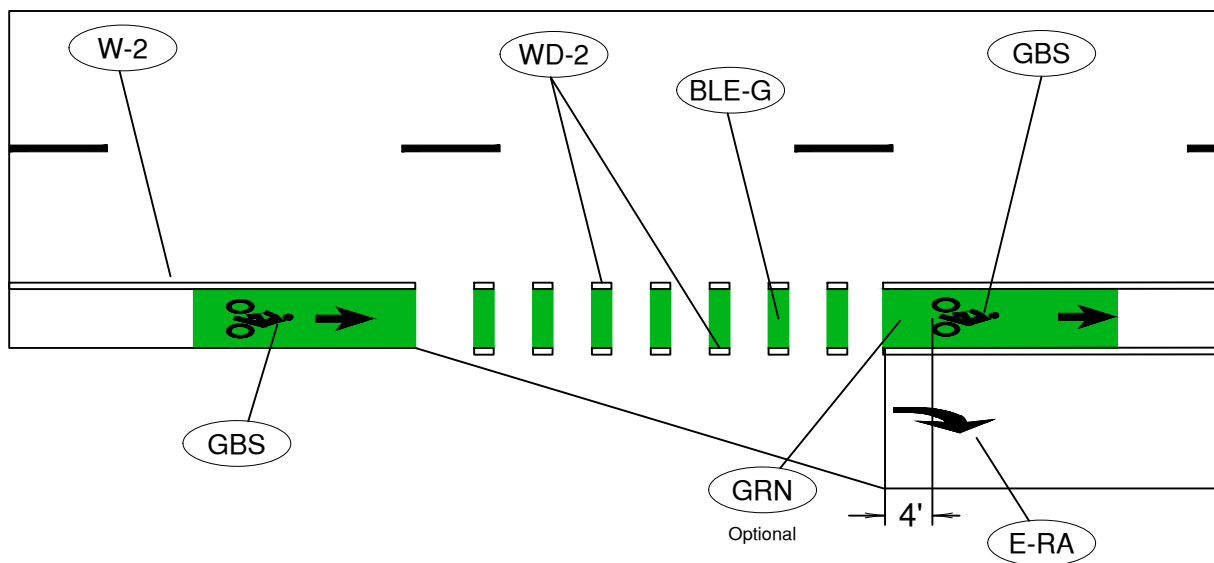

**TYPICAL GREEN SUPPLEMENTED BICYCLE LANE ACROSS AN ADDED RIGHT TURN LANE TAPER**

**NOTES:**

1. GREEN PAVEMENT MARKING USE PER DESIGN STANDARDS WITH CITY ENGINEER APPROVAL

DRAWN	AJD
DIV	ROADWAY
REV	DATE



**CITY OF BEND**

**CITY OF BEND**

STANDARD DRAWING

710 NW WALL ST., BEND, OREGON 97701

**INTERSECTION BIKE SAFETY**

SCALE NTS

DATE 11/01/2024

APPR

STD DWG R-44A

General Notes:

1. Where a curb clearly defines the roadway edge in the taper area, the edge line shown may be omitted in the taper area as determined by engineer judgement.
2. Motor vehicle speed adjacent to bicycle lane.

POSTED OR 85TH PERCENTILE SPEED (MPH) <sup>2</sup>	d (FT)	L (ft)
20	128	L=WS
25	152	
30	176	
35	184	
40	192	
45+	200	

WHERE:

L = taper length  
 W = width of bicycle lane being reduced (ft)  
 S = vehicle speed (mph)  
 "d" distances are for level roads.  
 Corrections should be made for grades.

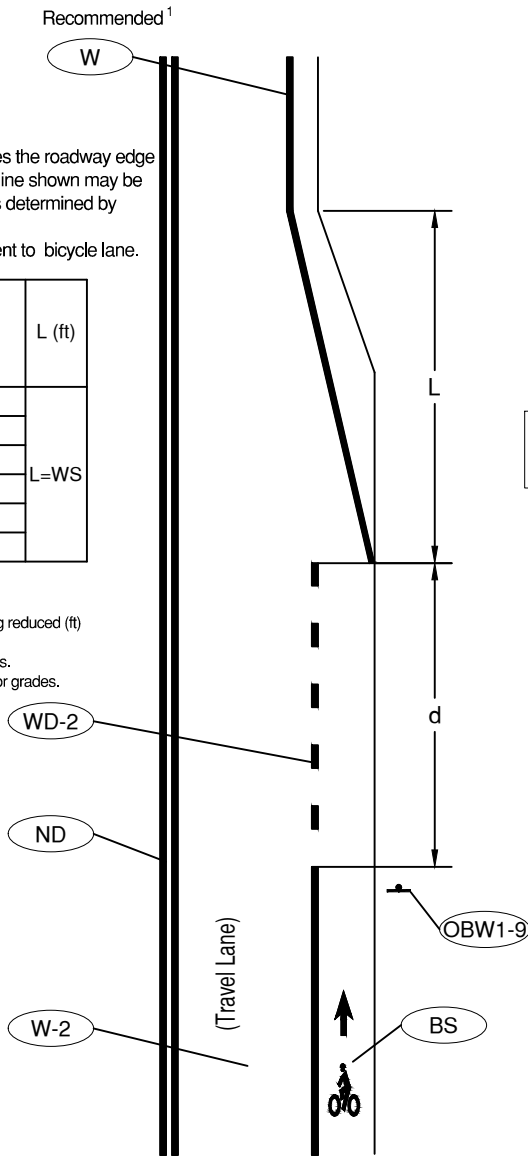

**END OF BIKE LANE**

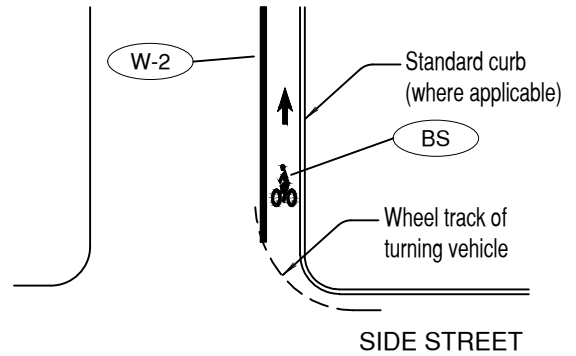

General Note:

Install bike lane stencil to avoid right turning vehicle wheel tracks.

**INSTALLATION OF BIKE LANE STENCILS FOLLOWING INTERSECTIONS**

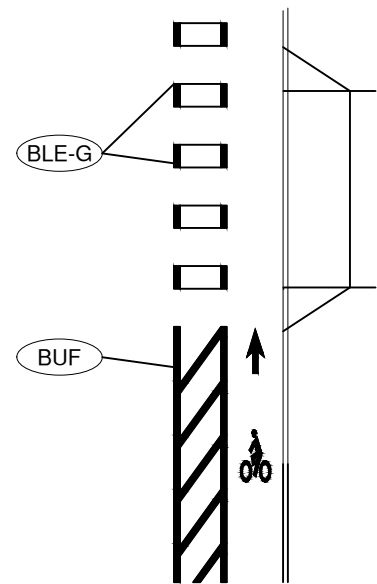

**BUFFER BIKE LANE IN CONFLICT AREA (FOR HIGH VOLUME COMMERCIAL DRIVEWAYS)**

To be accompanied by Standard Dwg. Nos. R-40 thru R-43 and R-44A

DRAWN	AJD
DIV	ROADWAY
REV	DATE



**CITY OF BEND**

**CITY OF BEND**

STANDARD DRAWING

710 NW WALL ST., BEND, OREGON 97701

**BIKE LANE MARKINGS**

SCALE NTS

DATE 11/01/2024

APPR

STD DWG R-44B

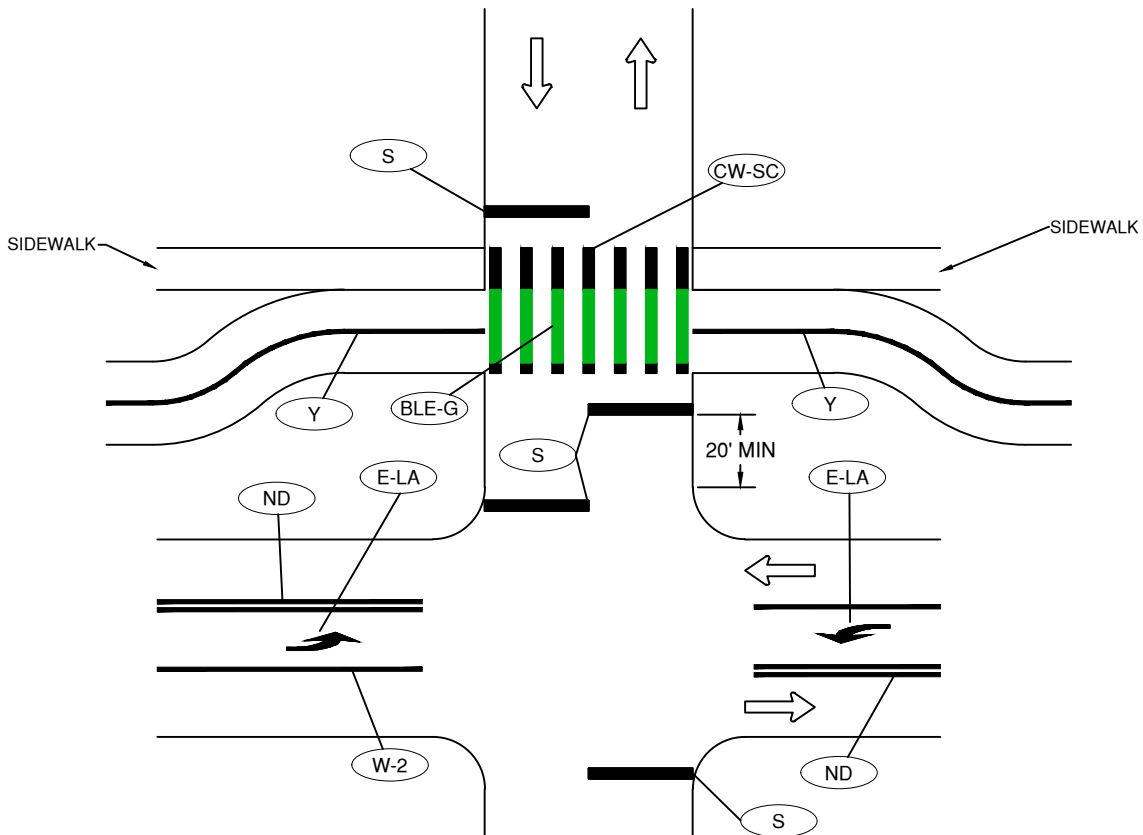

Typical 2-way separated marked bicycle crossing where path offset from street

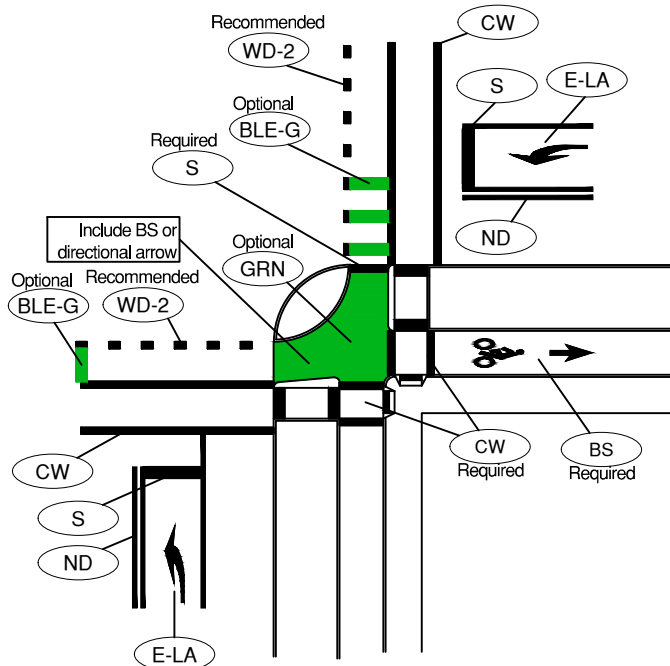

Example separated bicycle lane markings at a signalized intersection

DRAWN AJD	
DIV ROADWAY	
REV	DATE



**CITY OF BEND**  
 STANDARD DRAWING  
 710 NW WALL ST., BEND, OREGON 97701  
**BIKE LANE MARKINGS**

SCALE NTS
DATE 11/01/2024
APPR
STD DWG R-44C

1) Stop bar required at stop control approaches on arterials and collector streets

\* Stop bar shall be placed as near as possible to the intersecting traveled way. Locate stop bar 4' min. to 30' max. in advance of the extended fog line, edge of pavement, or curb face. Minimum stop bar distance may need to be increased, depending on location of pedestrian ramps (see Detail "A") and/or vehicle turn radii (see Detail "B"). Field verify sight distance and truck turning movements. Stop bar not required at local/local intersections.

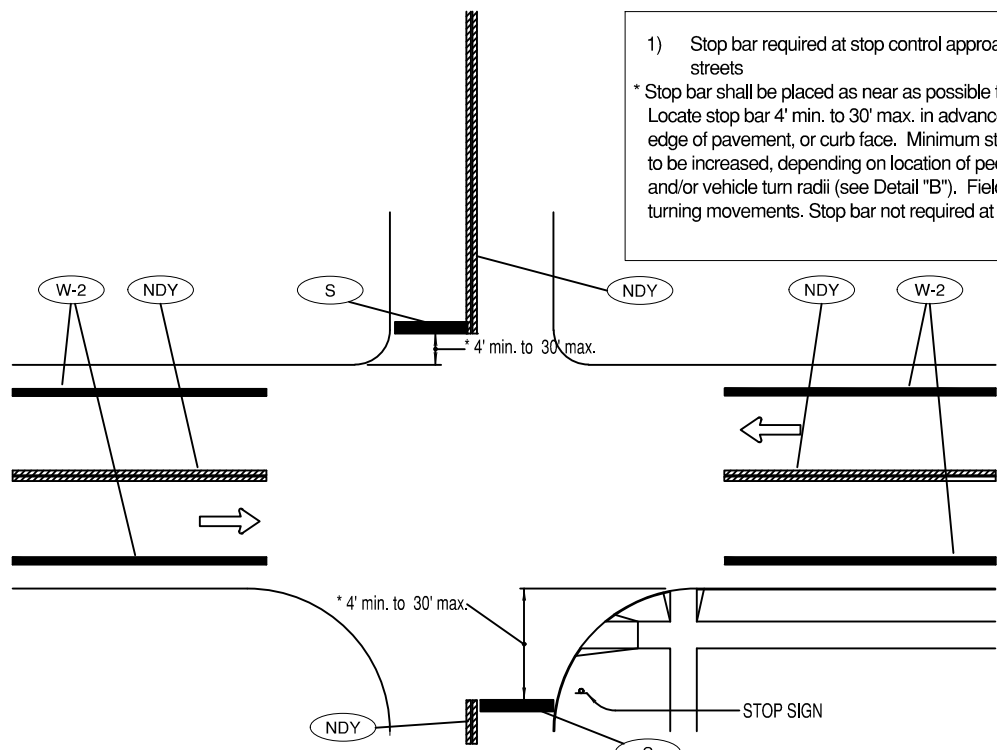

PAVEMENT MARKINGS FOR TYPICAL INTERSECTION

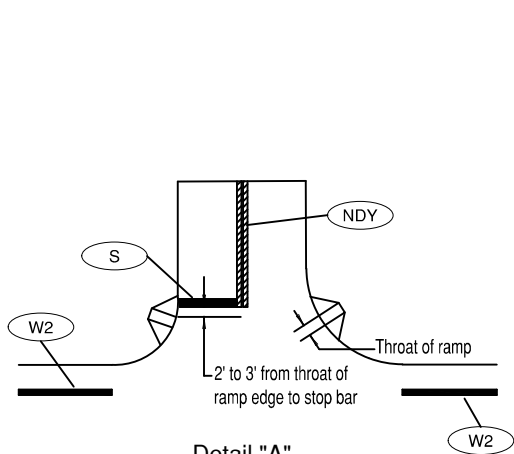

Detail "A"  
STOP BAR PLACEMENT WITH RESPECT TO PEDESTRIAN RAMP

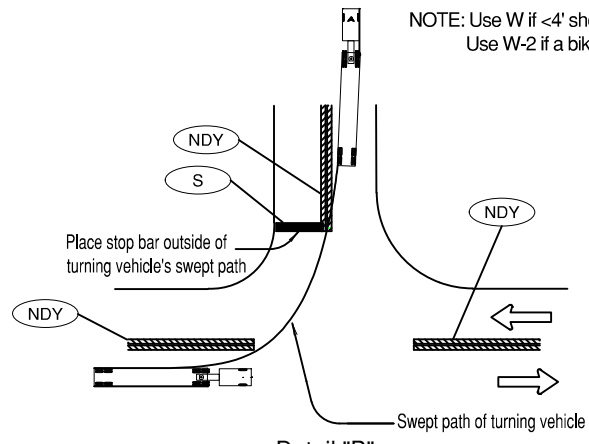

Detail "B"  
STOP BAR PLACEMENT WITH RESPECT TO TURN RADI WHERE NO RAMP

NOTE: Use W if <4' shoulder (no bike lane). Use W-2 if a bike lane exists.

To be accompanied by Standard Dwg. Nos. R-40 thru R-43

DRAWN AJD	
DIV ROADWAY	
REV	DATE



**CITY OF BEND**  
STANDARD DRAWING  
710 NW WALL ST., BEND, OREGON 97701

**INTERSECTION PAVEMENT MARKING LAYOUT**

SCALE NTS
DATE 01/31/2022
APPR
STD DWG R-45

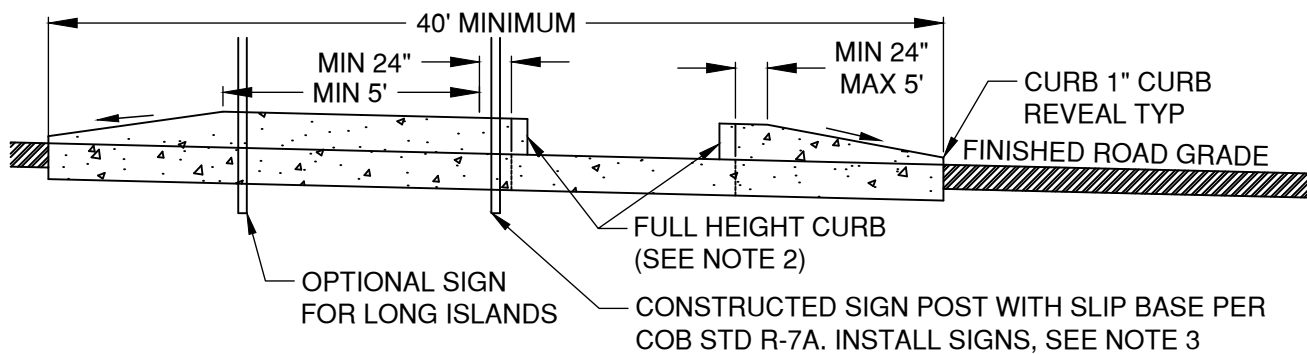
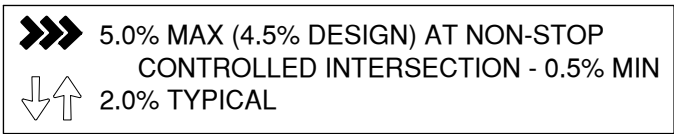
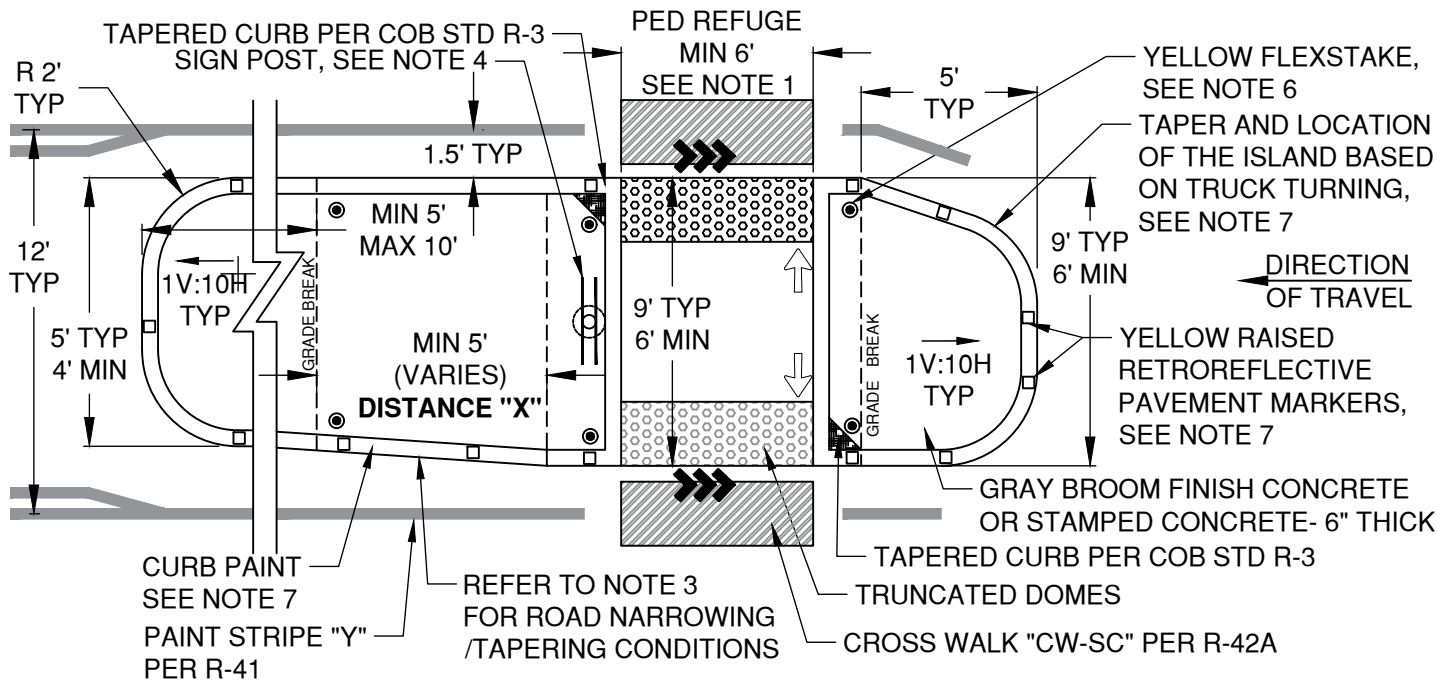

R4-7



R1-6A

NOTE: SEE STANDARD DRAWING 46.1 FOR PEDESTRIAN REFUGE ISLAND NOTES

DRAWN ARI  
 DIV ROADWAY  
 REV DATE



CITY OF BEND  
 STANDARD DRAWING

710 NW WALL ST., BEND, OREGON 97701

PEDESTRIAN REFUGE ISLAND

SCALE NTS

DATE 04/16/2026

APPR

STD DWG R-46

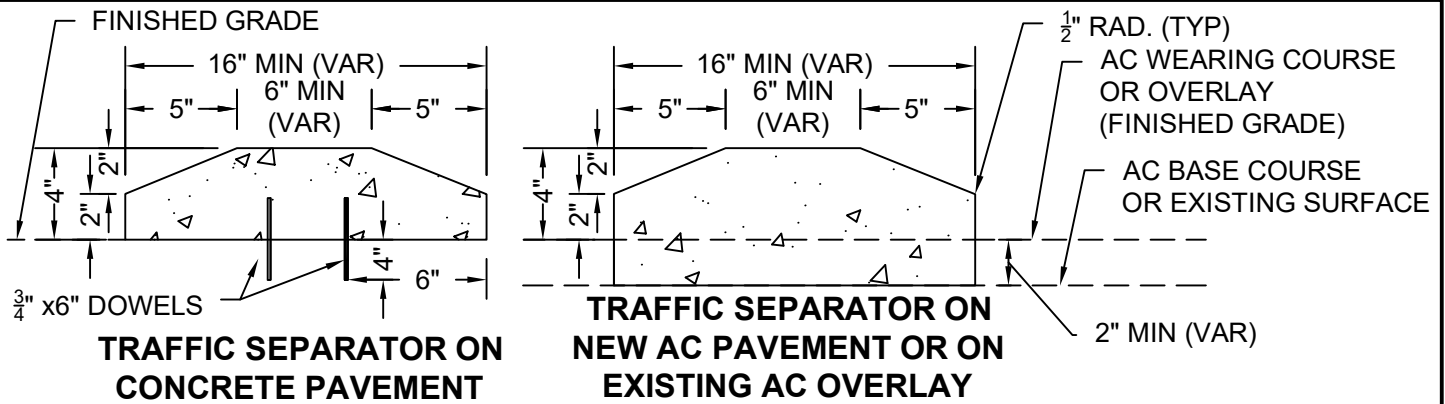

**TRAFFIC SEPARATOR ON CONCRETE PAVEMENT**

(ONLY USED WITH CITY ENGINEER APPROVAL. SEPARATOR SHOULD BE IMBEDDED WITHIN CONCRETE FOR NEW ROADWAYS)

**TRAFFIC SEPARATOR ON NEW AC PAVEMENT OR ON EXISTING AC OVERLAY**

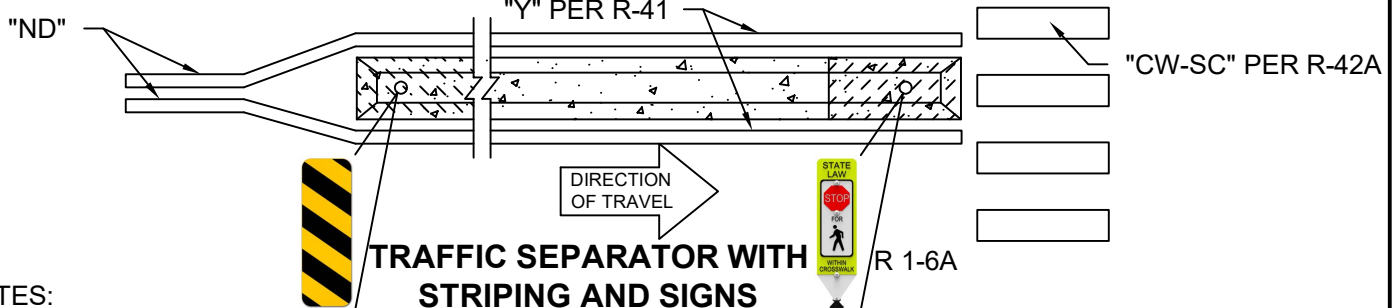
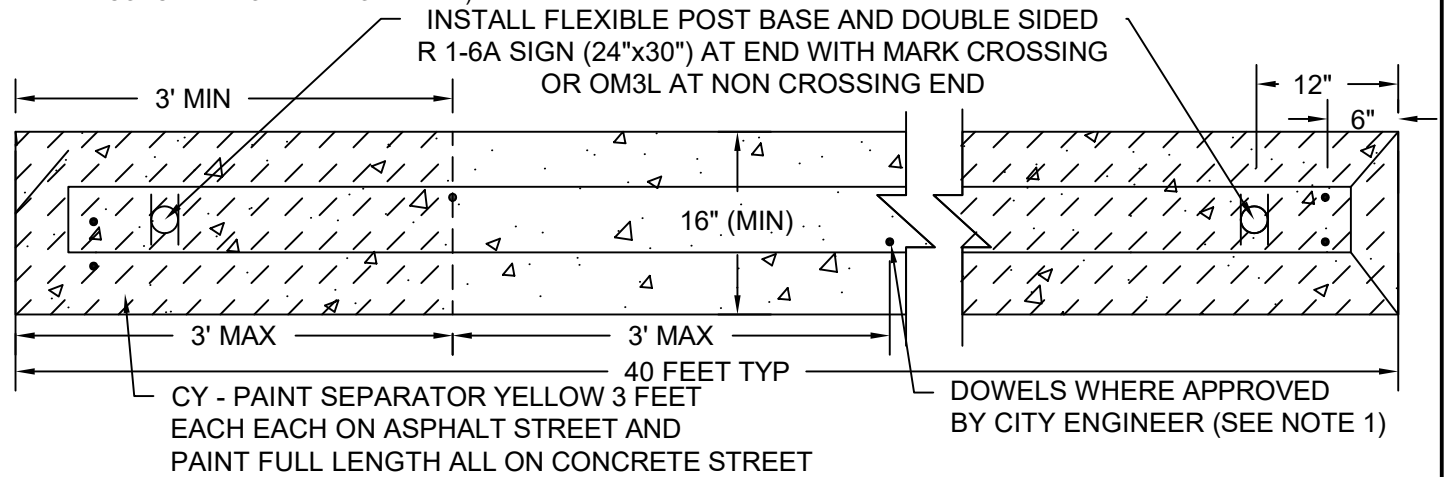

**NOTES:**

1. DOWELS TO BE USED IN LIMITED CASES WERE APPROVED BY THE CITY ENGINEER (TEMPORARY INSTALLATIONS OR WHERE THE SEPARATOR IS SHORT AND MAY NOT HAVE SUBSTANTIAL WEIGHT TO KEEP IN PLACE). WHEN DOWELS ARE APPROVED, THEY MUST BE 3/4" DIAMETER WITH LENGTH EXTENDING A MINIMUM 6" BELOW THE BOTTOM OF THE SEPARATOR. DOWELS TO BE SET BEFORE CONCRETE HARDENS.
2. TRANSVERSE JOINTS IN CONCRETE TRAFFIC SEPARATORS AND TRANSITIONS TO MATCH JOINTS IN CONCRETE PAVEMENT AND TO BE OF SAME TYPE.
3. SET JOINT SPACING 200' MAX FOR EXPANSION AND 15' MAX FOR CONTRACTION.
4. SITE CONDITIONS MAY REQUIRE A PROJECT SPECIFIC DRAIN OPENING WHICH CONSIDERS ROADWAY CONDITIONS (SHEET FLOW LIMITS, CROSS SLOPE, SUPER ELEVATION, ETC). WHERE BREAKS ARE REQUIRED IN THE SEPARATOR, THE OPENS MUST BE 12".
5. PLACE APPROVED PREFORMED FILLER ALONG ONE SIDE OF THE CONC. TRANSITIONS IN CONCRETE PAVEMENT AND AROUND ALL CURBED POINTS. WHERE SEPARATOR IS INSTALLED WITHIN ASPHALT, APPLY TACK COATS TO CONCRETE PRIOR TO PAVING.

DRAWN AJD	
DIV	ROADWAY
REV	DATE



CITY OF BEND

**CITY OF BEND**

STANDARD DRAWING

710 NW WALL ST., BEND, OREGON 97701

**TRAFFIC SEPERATOR**

SCALE NTS

DATE 11/01/2024

APPR

STD DWG R-46A

**NOTES:**

1. DOWELS TO BE USED IN LIMITED CASES WERE APPROVED BY THE CITY ENGINEER (TEMPORARY INSTALLATIONS OR WHERE THE SEPARATOR IS SHORT AND MAY NOT HAVE SUBSTANTIAL WEIGHT TO KEEP IN PLACE). WHEN DOWELS ARE APPROVED, THEY MUST BE 3/4" DIAMETER WITH LENGTH EXTENDING A MINIMUM 6" BELOW THE BOTTOM OF THE SEPARATOR. DOWELS TO BE SET BEFORE CONCRETE HARDENS.
2. TRANSVERSE JOINTS IN CONCRETE TRAFFIC SEPARATORS AND TRANSITIONS TO MATCH JOINTS IN CONCRETE PAVEMENT AND TO BE OF SAME TYPE.
3. SET JOINT SPACING 200' MAX FOR EXPANSION AND 15' MAX FOR CONTRACTION.
4. SITE CONDITIONS MAY REQUIRE A PROJECT SPECIFIC DRAIN OPENING WHICH CONSIDERS ROADWAY CONDITIONS (SHEET FLOW LIMITS, CROSS SLOPE, SUPER ELEVATION, ETC). WHERE BREAKS ARE REQUIRED IN THE SEPARATOR, THE OPENS MUST BE 12".
5. PLACE APPROVED PREFORMED FILLER ALONG ONE SIDE OF THE CONC. TRANSITIONS IN CONCRETE PAVEMENT AND AROUND ALL CURBED POINTS. WHERE SEPARATOR IS INSTALLED WITHIN ASPHALT, APPLY TACK COATS TO CONCRETE PRIOR TO PAVING.

DRAWN <b>AJD</b>		 <b>CITY OF BEND</b>	<b>CITY OF BEND</b> STANDARD DRAWING 710 NW WALL ST., BEND, OREGON 97701		SCALE NTS
DIV <b>ROADWAY</b>			<b>TRAFFIC SEPARATOR</b>		DATE <b>04/16/2026</b>
REV	DATE				APPR
				STD DWG <b>R-46A.1</b>	

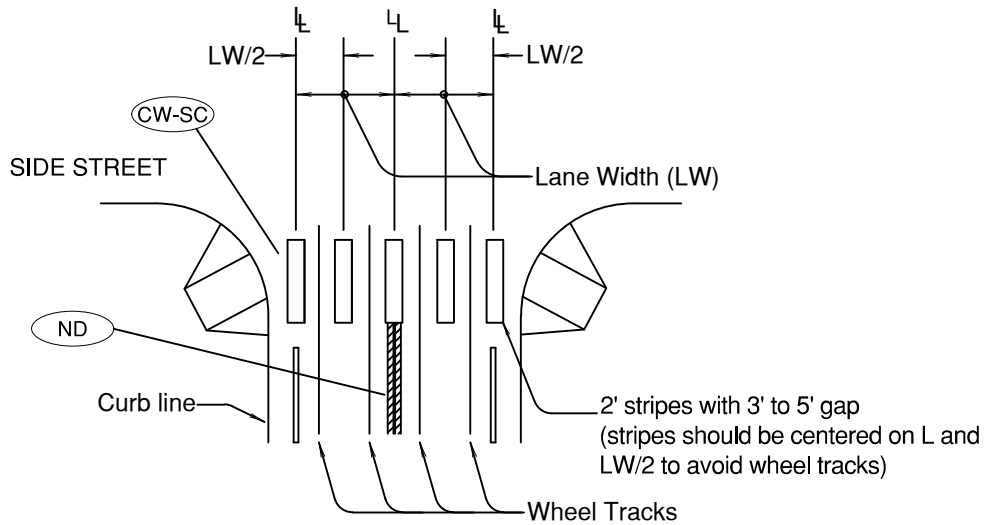

**STAGGERED CONTINENTAL LAYOUT**

General Note:

1. Install crosswalk bars such that the throat of the ADA ramp is entirely within crosswalk markings, or 5' back of extended fog line, edge of pavement, or curb face.

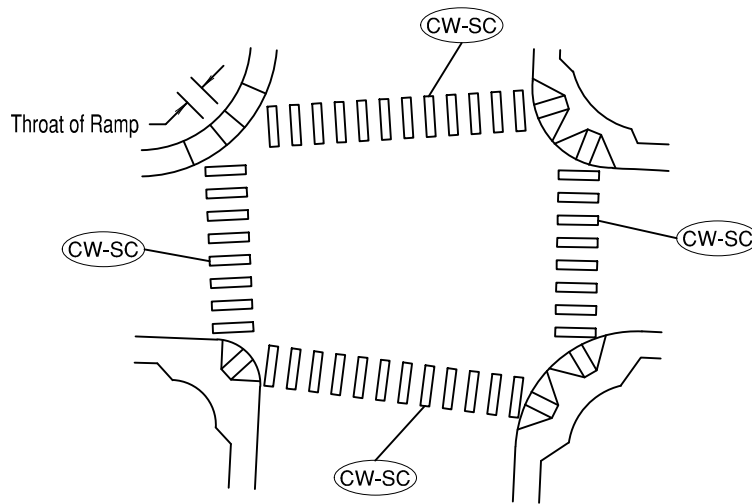

**STANDARD CROSSWALK MARKING  
AT 4-WAY CONTROLLED  
INTERSECTION**

To be accompanied by Standard Dwg. Nos. R-40 thru R-43

DRAWN ARI	
DIV ROADWAY	
REV	DATE



**CITY OF BEND**

**CITY OF BEND**

STANDARD DRAWING

710 NW WALL ST., BEND, OREGON 97701

**CROSSWALK MARKINGS**

SCALE NTS

DATE 04/16/2026

APPR

STD DWG R-47

TRANSITION AT EDGE WITH NATIVE  
TOPSOIL AND NATIVE GRASS SEED  
SUITABLE TO THE SITE

PAVED TRAIL  
3" ASPHALT 4" BASE COURSE OF  
5/8" MINUS AGGREGATE.

CROSS SLOPE PATH TO  
DRAIN AT 1.5%

IF TRAIL IS USED AS  
SERVICE ACCESS, INCREASE  
PAVING THICKNESS

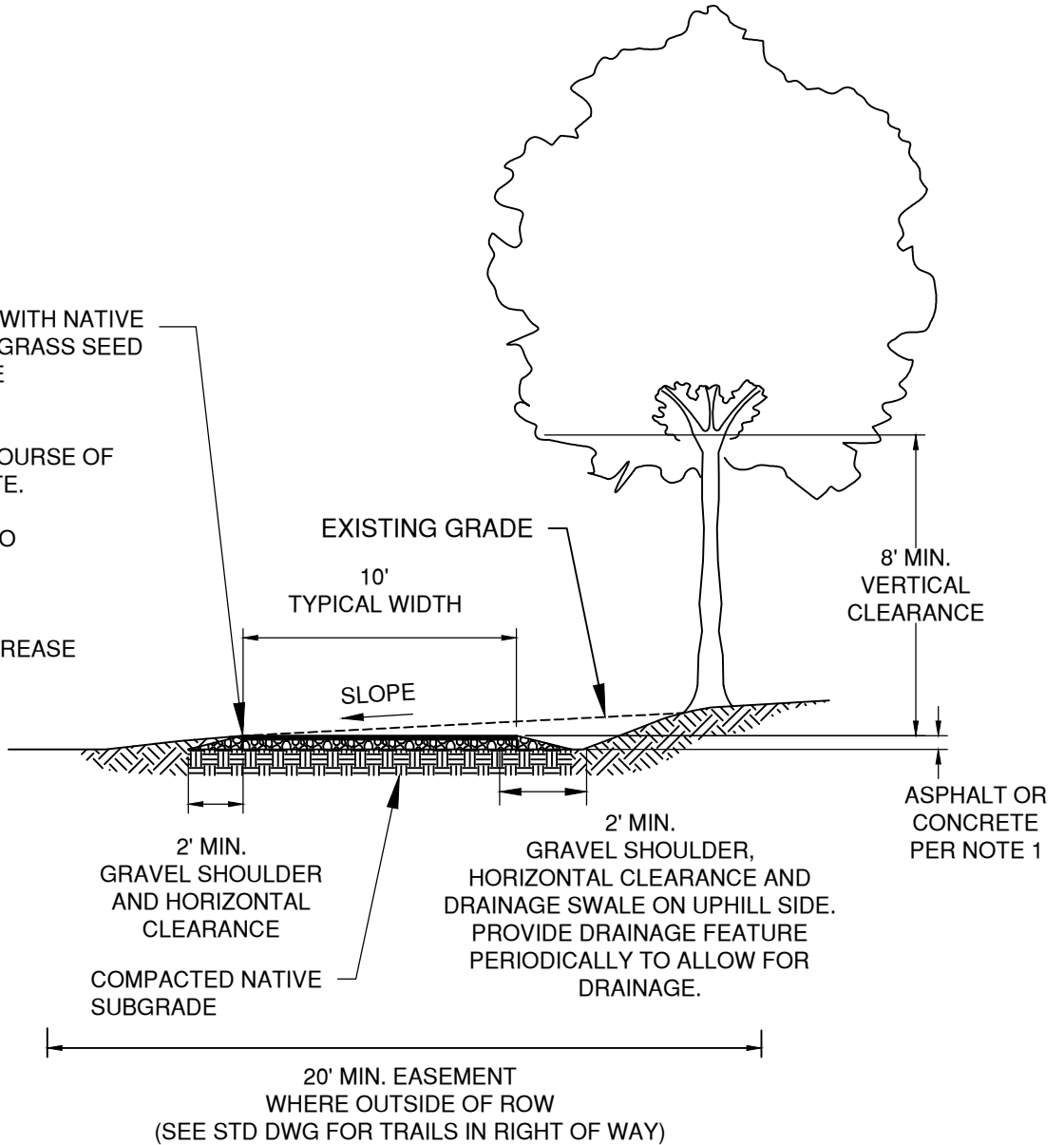

NOTES:

1. PRIMARY TRAIL SHALL BE PAVED WITH ASPHALT OR CONCRETE IN THE RIGHT-OF-WAY OR ADJACENT TO STREETS. OUTSIDE OF THE RIGHT-OF-WAY TRAIL MAY BE AGGREGATE AS APPROVED.
2. PRIMARY TRAILS ARE TYPICALLY FACILITIES OUTSIDE OF THE PUBLIC RIGHT-OF-WAY THAT ARE OWNED AND MAINTAINED BY THE BEND PARKS AND RECREATION DISTRICT OR PRIVATELY. (SEE STANDARD CROSS-SECTIONS FOR CITY SHARED USE PATHS IN THE RIGHT-OF-WAY.)
3. WHERE OUTSIDE OF RIGHT-OF-WAY, TRAIL EASEMENT DEDICATION IS REQUIRED INCLUDING A PUBLIC ACCESS EASEMENT AND UTILITY EASEMENT WHERE APPLICABLE.
4. TRAIL ALIGNMENTS ARE ENCOURAGED TO MEANDER AND NOT BE DESIGNED AS FENCED CANYONS.
5. TRAILS WITHIN RIGHT-OF-WAY SHALL MEET PROWAG REQUIREMENTS. TRAILS OUT OF RIGHT-OF-WAY SHALL MEET THE REQUIREMENTS OF THE UNITED STATES ACCESS BOARD ACCESSIBILITY STANDARDS FOR FEDERAL OUTDOOR DEVELOPED AREAS.

DRAWN	AJD
DIV	ROADWAY
REV	DATE



CITY OF BEND

CITY OF BEND

STANDARD DRAWING

710 NW WALL ST., BEND, OREGON 97701

PRIMARY TRAIL

SCALE NTS

DATE 01/31/2022

APPR

STD DWG R-48

TRANSITION AT EDGE WITH NATIVE TOPSOIL AND NATIVE GRASS SEED SUITABLE TO THE SITE

PAVED TRAIL  
2.5" ASPHALT 4" BASE COURSE OF 5/8" MINUS AGGREGATE

AGGREGATE TRAIL  
2" TOP COURSE OF 3/8" MINUS COMPACTED 4" BASE COURSE OF 5/8" MINUS COMPACTED

CROSS SLOPE PATH TO DRAIN AT 1.5%

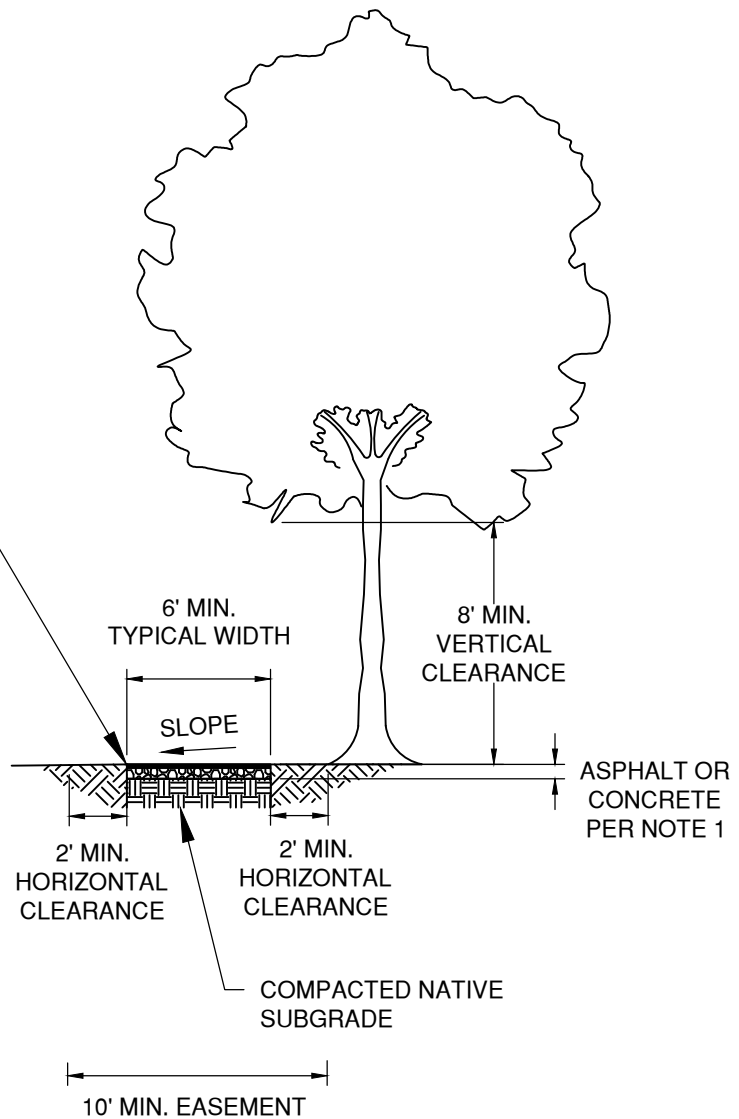

NOTES:

- CONNECTOR TRAIL SHALL BE PAVED WITH ASPHALT OR CONCRETE IN THE RIGHT-OF-WAY OR ADJACENT TO STREETS. OUTSIDE OF THE RIGHT-OF-WAY TRAIL MAY BE AGGREGATE AS APPROVED.
- CONNECTOR TRAILS ARE TYPICALLY FACILITIES OUTSIDE OF THE PUBLIC RIGHT-OF-WAY THAT ARE OWNED AND MAINTAINED BY THE BEND PARKS AND RECREATION DISTRICT OR PRIVATELY. (SEE STANDARD CROSS-SECTIONS FOR CITY SHARED USE PATHS IN THE RIGHT-OF-WAY.)
- WHERE OUTSIDE OF RIGHT-OF-WAY, TRAIL EASEMENT DEDICATION IS REQUIRED INCLUDING A PUBLIC ACCESS EASEMENT AND UTILITY EASEMENT WHERE APPLICABLE.
- TRAIL ALIGNMENTS ARE ENCOURAGED TO MEANDER AND NOT BE DESIGNED AS FENCED CANYONS.
- NATIVE SURFACE TRAILS MAY BE USED WITHIN PARKS OR PRIVATE DEVELOPMENTS TO PROVIDE CONNECTIONS TO PRIMARY AND OTHER CONNECTOR TRAILS.
- TRAILS WITHIN RIGHT-OF-WAY SHALL MEET PROWAG REQUIREMENTS. TRAILS OUT OF RIGHT-OF-WAY SHALL MEET THE REQUIREMENTS OF THE UNITED STATES ACCESS BOARD ACCESSIBILITY STANDARDS FOR FEDERAL OUTDOOR DEVELOPED AREAS AT A MINIMUM.

DRAWN AJD	
DIV ROADWAY	
REV	DATE



CITY OF BEND

CITY OF BEND

STANDARD DRAWING

710 NW WALL ST., BEND, OREGON 97701

CONNECTOR TRAIL

SCALE NTS

DATE 01/31/2022

APPR

STD DWG R-49

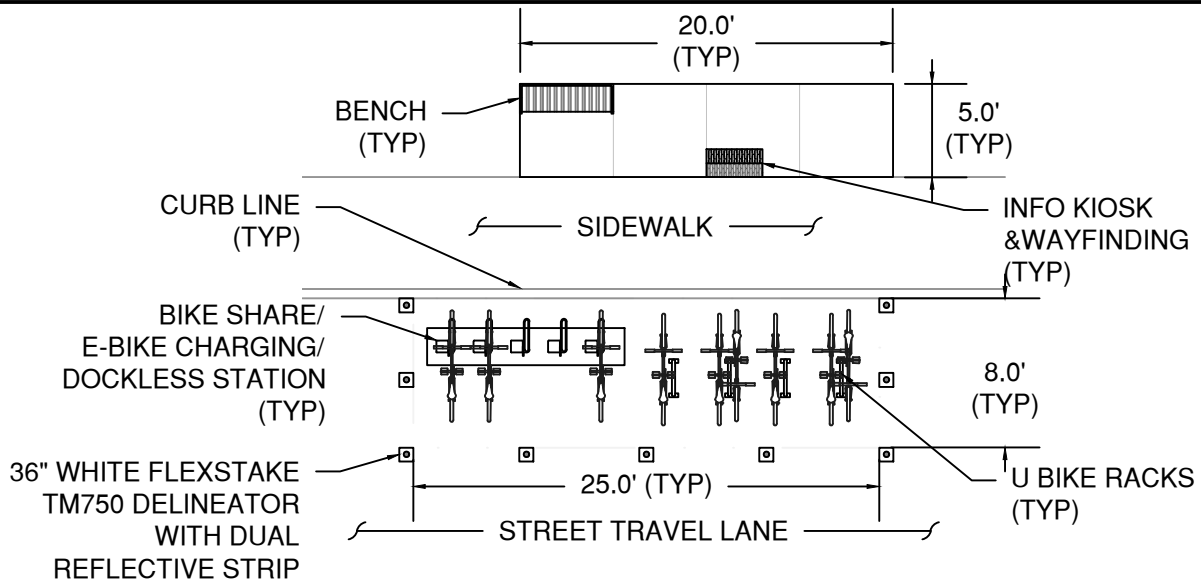

SMALL MOBILITY POINT

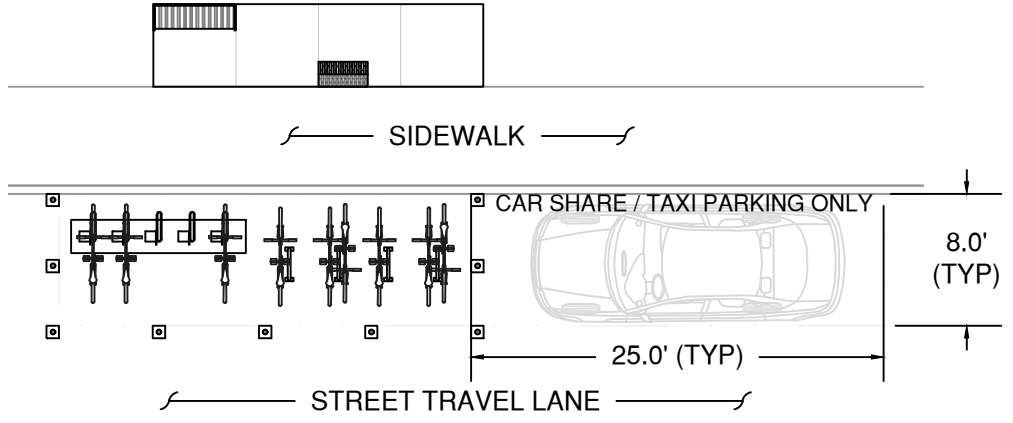

MEDIUM MOBILITY POINT

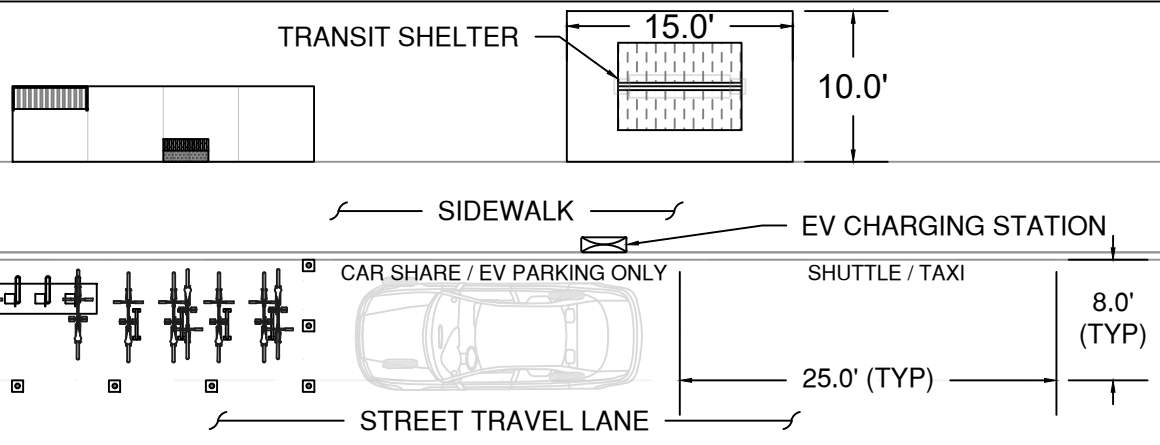

MEDIUM (+) MOBILITY POINT

- NOTES:
1. LOCATION & EXISTING CONDITIONS WILL DETERMINE LAYOUT
  2. FINAL LAYOUT MUST MEET MINIMUM ADA STANDARDS FOR ACCESSIBLE DESIGN
  3. ALL CONCEPTS SHOWN ARE FOR SPATIAL REPRESENTATION ONLY
  4. BICYCLE PARKING STATIONS MAY BE PLACED WITH IN ON-STREET PARKING SPACES OR ON PRIVATE PROPERTY

DRAWN AJD	
DIV ROADWAY	
REV	DATE



**CITY OF BEND**  
STANDARD DRAWING  
710 NW WALL ST., BEND, OREGON 97701

**MOBILITY POINTS - SMALL/MEDIUM**

SCALE NTS
DATE 11/01/2024
APPR
STD DWG R-50A

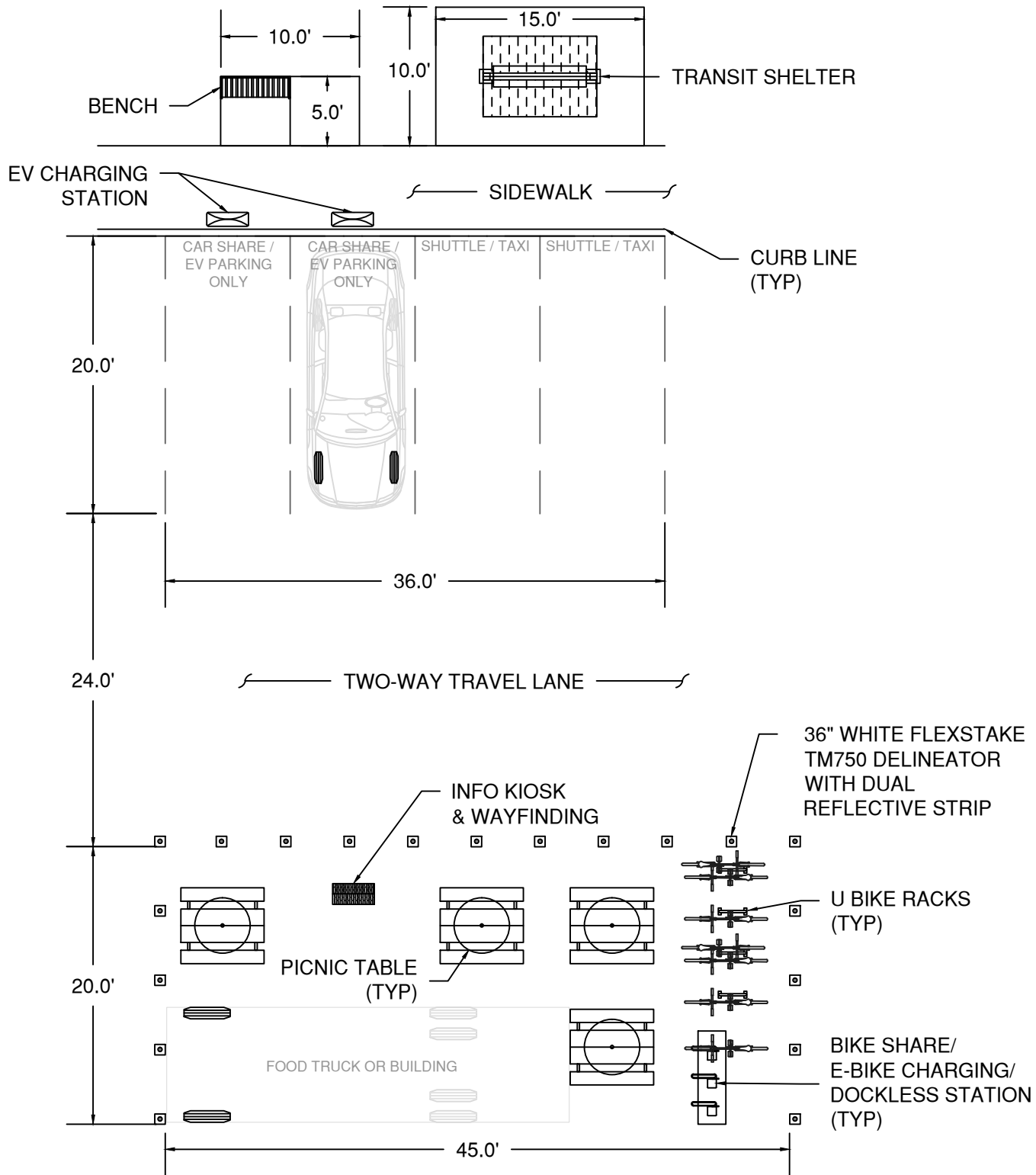

NOTES:

1. LOCATION & EXISTING CONDITIONS WILL DETERMINE LAYOUT
2. FINAL LAYOUT MUST MEET MINIMUM ADA STANDARDS FOR ACCESSIBLE DESIGN
3. ALL CONCEPTS SHOWN ARE FOR SPATIAL REPRESENTATION ONLY

DRAWN AJD	
DIV	ROADWAY
REV	DATE



CITY OF BEND

STANDARD DRAWING

710 NW WALL ST., BEND, OREGON 97701

MOBILITY POINTS - LARGE

SCALE NTS

DATE 11/01/2024

APPR

STD DWG R-50B

---

**CITY OF BEND STANDARD DRAWINGS**

**Sanitary (S)**

---

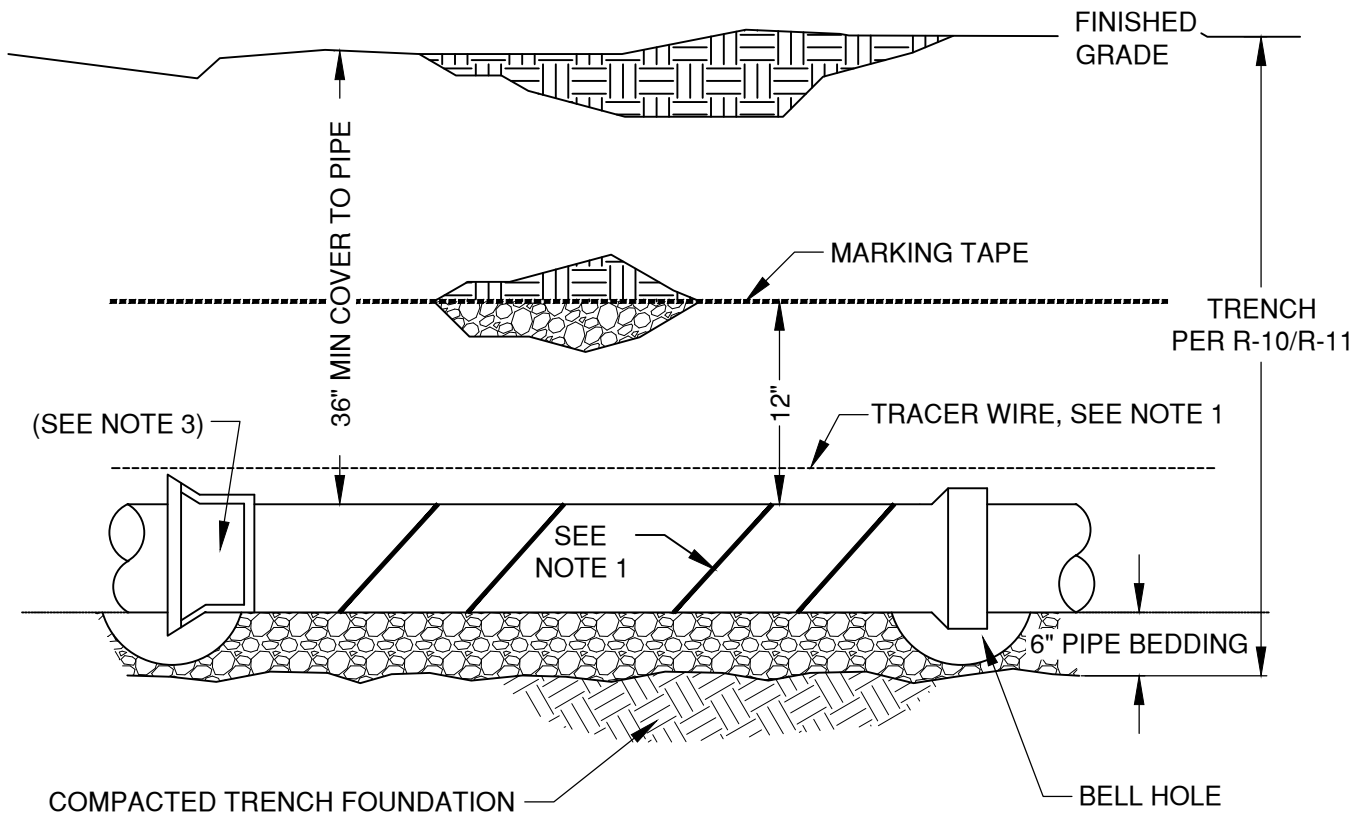

**NOTES:**

1. FOR PRESSURE AND VACUUM SEWER MAINS ONLY, TRACER WIRE SHALL BE CENTERED ON TOP OF THE MAIN, AS CLOSE TO THE MAIN AS POSSIBLE. THE MAIN SHALL BE WRAPPED WITH MARKING TAPE A MIN OF 4 WRAPS PER 20 FEET OF MAIN. TRACER WIRE IS NOT REQUIRED ON GRAVITY SEWER MAIN.
2. PLACE TRACER WIRE ON GRAVITY, PRESSURE, AND VACUUM SEWER SERVICES. TRACER WIRE AND MARKING TAPE TO BE PER SPECIFICATION SECTION 00445.11.
3. TRANSITION FITTING SHALL BE A HARD COUPLER WHERE CHANGING PIPE MATERIAL
4. WHEN A SEWER LINE IS LOCATED ABOVE OR WITHIN 18" BELOW A WATERLINE, THE SEWER SHALL BE CONSTRUCTED WITH A MIN OF 20 LF OF AWWA C900 OR AWWA C905 PIPE CENTERED AT THE WATERLINE PER OAR 333-061-0050(9) AND BE APPROVED BY CITY/STATE.
5. WHEN INSTALLING A WATER LINE THAT CROSSES BELOW OR WITHIN 18 INCHES ABOVE A NON-POTABLE LINE, FOLLOW OAR 333-061-0050(9). ALL NON-POTABLE LINES SHALL BE TREATED AS "SEWER" LINES AS DESCRIBED IN OAR 333-061-0050(9).
6. COMPACTION SHALL MEET 00405.46(c) PER COB SPECIAL PROVISIONS

DRAWN AJD	
DIV SANITARY	
REV	DATE



**CITY OF BEND**  
STANDARD DRAWING  
710 NW WALL ST., BEND, OREGON 97701

**SEWER MAIN TYPICAL PROFILE**

SCALE NTS
DATE 01/31/2022
APPR
STD DWG S-1

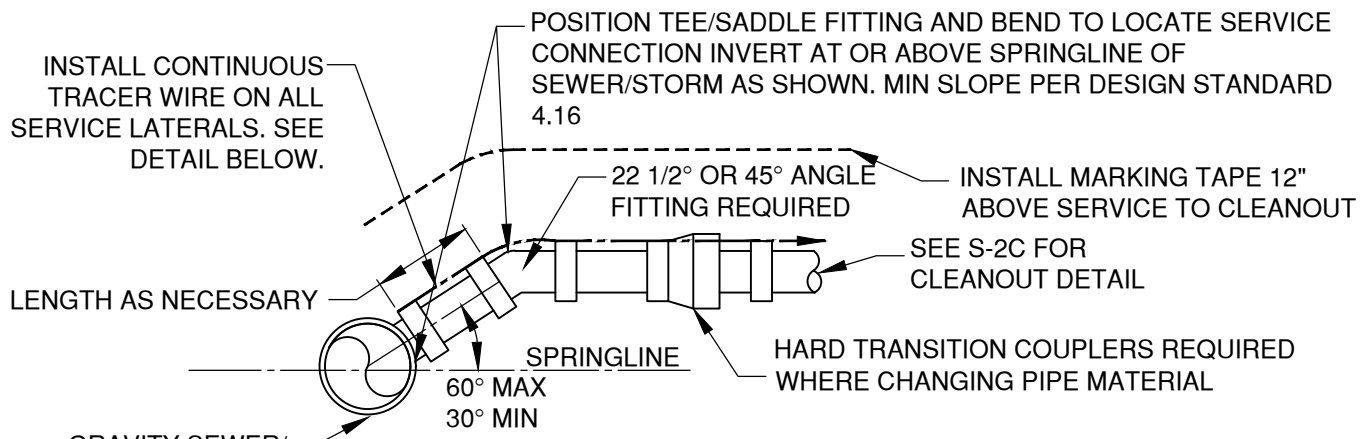

**STANDARD SERVICE**

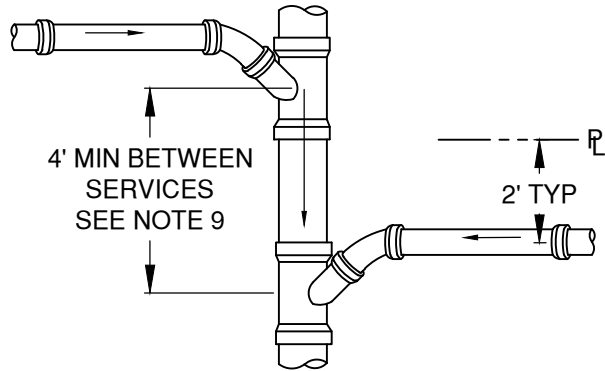

**WYE SERVICE CONNECTION**

(FOR USE ON MAINS 12" AND SMALLER)

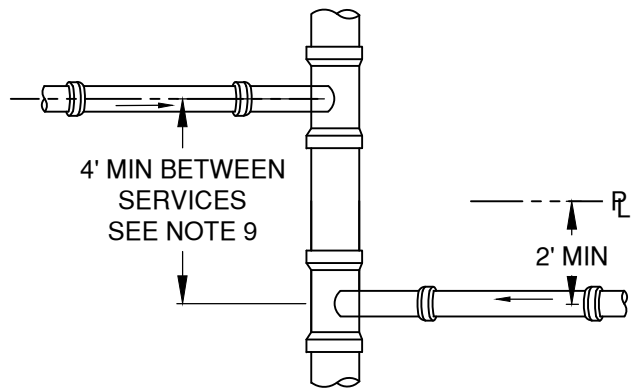

**TEE SERVICE CONNECTION**

(FOR USE ON MAINS LARGER THAN 12" OR ON EXISTING MAINS FOR INFILL SERVICE CONNECTIONS)

**NOTES:**

1. ALL TRENCHES TO CONFORM TO STD DWG R-10
2. SERVICES OFF NEW MAINS SHALL BE WYE OR TEE CONNECTIONS. SEE STD DWG S-2B FOR SERVICES OFF EXISTING MAINS
3. TRACER WIRE REQUIRED ON ALL SEWER / STORM SERVICES. MARKING TAPE SHALL BE INSTALLED AS SHOWN.
4. SEWER / STORM CONNECTION FROM THE PROPERTY LINE/ROW LINE TO THE CLEAN OUT NEAR THE BUILDING FOUNDATION REQUIRES A PLUMBING PERMIT.
5. WHEN A SEWER SERVICE IS LOCATED ABOVE OR WITHIN 18" BELOW A WATERLINE, THE SEWER SERVICE SHALL BE CONSTRUCTED WITH A MIN. 20 LF OF AWWA C900 OR AWWA C905 PIPE CENTERED AT THE WATERLINE PER OAR 333-061-0050(9).
6. STANDARD RESIDENTIAL SEWER SERVICES ARE 4"Ø. COMMERCIAL, INDUSTRIAL SEWER SERVICES ARE 6"Ø UNLESS OTHERWISE SIZED LARGER BY THE SITE'S ENGINEER.
7. WHERE A SERVICE CROSSES A NEW CURB, STAMP THE FACE OF CURB PER STD DWG R-3.
8. GRAVITY SEWER STANDARDS APPLY TO STORM SEWER MAINS.
9. MINIMUM 3' SECTIONS OF PIPE ARE REQUIRED BETWEEN FITTINGS.
10. ALL STORM SEWER LATERALS MUST COMPLY WITH CITY SEWER STANDARDS.

DRAWN AJD DIV SANITARY REV DATE	 <b>CITY OF BEND</b>	<b>CITY OF BEND</b> STANDARD DRAWING 710 NW WALL ST., BEND, OREGON 97701	SCALE NTS DATE 03/22/2023 APPR STD DWG S-2A
		<b>GRAVITY SEWER/STORM SERVICES ON NEW MAINS</b>	

APPLY PREDCO PE44  
EXOTHERMIC EPOXY, OR  
APPROVED EQUAL,  
AROUND GASKET SEALS

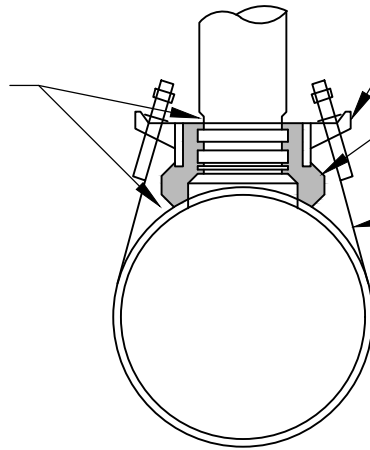

DUCTILE IRON SADDLE CASTING ROMAC  
STYLE "CB" OR APPROVED EQUAL

SBR GASKET

ADJUSTABLE STAINLESS  
STEEL STRAP

## SEWER SADDLE

### NOTES:

1. INSTALL SERVICE LATERAL PER STD DWG S-2A
2. CONNECTION TO EXISTING MAINS MAY BE CUT-IN FITTINGS PER STD DWG S-2A OR TAPS PER THIS DETAIL. PVC MAINS TO UTILIZE CUT IN FITTINGS UNLESS APPROVED BY THE CITY ENGINEER.
3. SEWER SADDLE SHALL BE ROMAC STYLE "CB" OR APPROVED EQUAL.
4. INSTALL CONNECTION PER THE MANUFACTURER'S RECOMMENDATIONS.
5. GASKET SEAL EPOXY NOT TO BE INSTALLED ON PVC MAINS.

DRAWN AJD	
DIV SANITARY	
REV	DATE



**CITY OF BEND**

**CITY OF BEND**

STANDARD DRAWING

710 NW WALL ST., BEND, OREGON 97701

**GRAVITY SEWER/STORM SERVICE CONNECTION TO  
EXISTING MAIN**

SCALE NTS

DATE 11/01/2024

APPR

STD DWG S-2B

STORM: 4" CLEANOUT, USE 6" C900 VERTICAL STAND PIPE (MIN. 18" LENGTH) WITH CAST IRON LID WITH CAST LETTERING "STORM" OR APPROVED EQUAL. SEE NOTE 2

SEWER: 4" CLEANOUT, USE 6" C900 VERTICAL STAND PIPE (MIN. 18" LENGTH) AND CAST IRON LID WITH CAST LETTERING "SEWER" OR APPROVED EQUAL. SEE NOTE 2

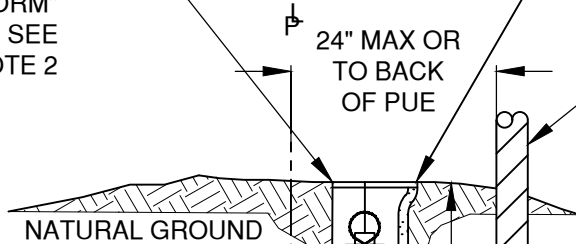

MARK SERVICE STUB AT ROW WITH PRESSURE TREATED WOOD OR CAPPED PVC EXTENDING 2' ABOVE EXISTING GROUND. PAINT MARKER GREEN FOR SEWER OR PURPLE FOR STORM.

INSTALL CONTINUOUS TRACER WIRE ON ALL SERVICE LATERALS.

EXTEND 6" BEYOND CLEANOUT; COIL MIN 24" OF TRACER WIRE AT RIGHT OF WAY LINE. TRACER WIRE TO BE EXTENDED TO CLEANOUT AT STRUCTURE UNDER BUILDING PERMIT.

NOTE: SEE S-2A AND S-2B FOR SERVICE DETAILS

REMOVABLE PLUG OR CAP

4"x4" WYE (RES TYP)  
6"x4" WYE (IND/COMM TYP)

NOTES:

1. SEE STD DWG S-2A FOR GENERAL NOTES.
2. INSTALL CONCRETE BROOKS BOX WITH CAST IRON LID ON ALL CLEANOUTS WITHIN HARDSCAPE.

DRAWN	AJD
DIV	SANITARY
REV	DATE



CITY OF BEND

CITY OF BEND

STANDARD DRAWING

710 NW WALL ST., BEND, OREGON 97701

GRAVITY SEWER/STORM CLEANOUT

SCALE NTS

DATE 03/22/2023

APPR

STD DWG S-2C

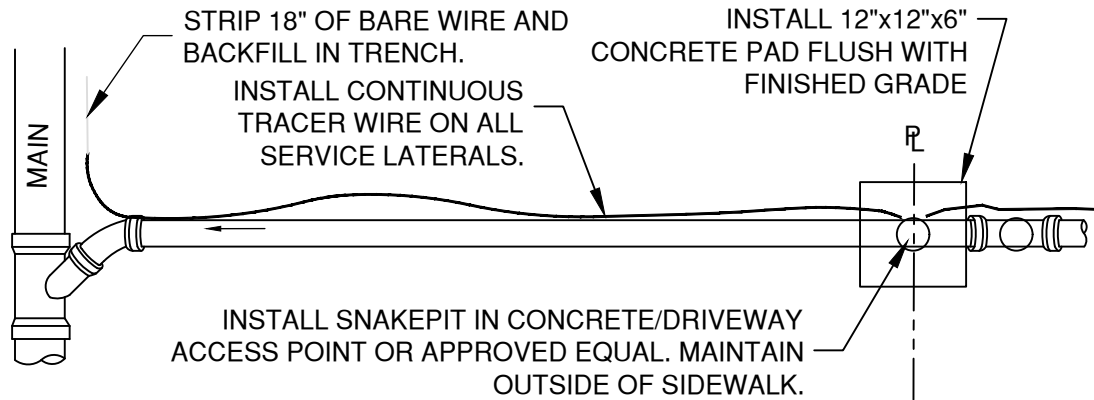

### TRACER WIRE GROUNDING

4" CLEANOUT WITH LID READING "SEWER".  
FOR STORM, CONCRETE BROOKS BOX  
WITH CAST IRON LID  
READING "STORM" OR APPROVED EQUAL.  
SEE NOTE 2.

INSTALL SNAKEPIT CD14\*2T-SW  
DOUBLE TERMINAL (UTILIZING  
GROUND TERMINAL FOR THE  
CONTINUATION TO THE  
PROPERTY) OR APPROVED  
EQUAL

24" MAX OR  
TO BACK  
OF PUE

MARK SERVICE STUB AT ROW  
WITH PRESSURE TREATED WOOD  
OR CAPPED PVC EXTENDING 2'  
ABOVE EXISTING GROUND. PAINT  
MARKER GREEN FOR SEWER OR  
PURPLE FOR STORM.

INSTALL CONTINUOUS  
TRACER WIRE ON ALL  
SERVICE LATERALS.

EXTEND 6" BEYOND CLEANOUT;  
COIL MIN 24" OF TRACER WIRE.  
TRACER WIRE TO BE EXTENDED  
TO CLEANOUT AT STRUCTURE  
UNDER BUILDING PERMIT.

4" CLEANOUT, USE 6" C900 VERTICAL  
STAND PIPE (MIN. 18" LENGTH)

REMOVABLE  
PLUG OR CAP

4"x4" WYE (RES TYP)  
6"x4" WYE (IND/COMM TYP)

**NOTES:**

1. SEE STD DWG S-2A FOR GENERAL NOTES.
2. INSTALL CONCRETE BROOKS BOX WITH CAST IRON LID ON ALL CLEANOUT OUTSIDE OF SIDEWALK BUT WITHIN HARDSCAPE.
3. SEE S-2A AND S-2B FOR SERVICE DETAILS.

DRAWN AJD	
DIV SANITARY	
REV	DATE



CITY OF BEND

**CITY OF BEND**

STANDARD DRAWING

710 NW WALL ST., BEND, OREGON 97701

**GRAVITY SEWER/STORM CLEANOUT - SNAKEPIT/**

SCALE NTS

DATE 04/16/2026

APPR

STD DWG S-2D

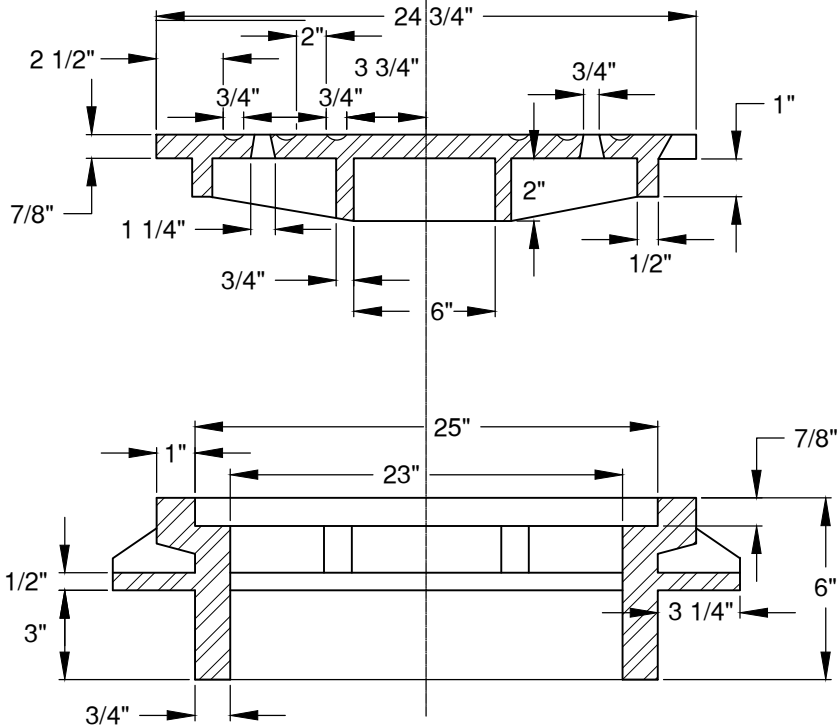
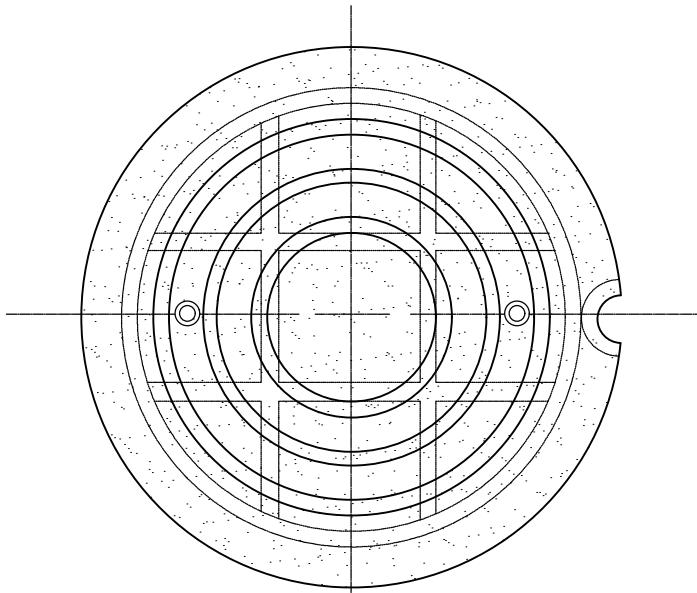

**SEWER MANHOLE LID DETAIL  
NTS**

**NOTES:**

1. CITY SANITARY SEWER MANHOLE COVERS SHALL HAVE THE WORD "SEWER" CAST IN 2" RAISED LETTERS.
2. PRIVATE MANHOLE LIDS SHOULD NOT USE THE CITY OF BEND MANHOLE LID DETAIL.
3. HINGED MANHOLE LIDS ARE NOT PERMITTED UNLESS OTHERWISE APPROVED BY THE CITY ENGINEER.
4. LOCKS ARE TO BE USED ON THE LID WHEN THE LID IS LOCATED OUTSIDE A ROADWAY IF REQUIRED BY THE CITY ENGINEER.
5. MANHOLE LIDS SHALL BE PLACED OUTSIDE THE PATH OF TRAVEL ON SIDEWALKS AND DRIVEWAY APRONS.

DRAWN	AJD
DIV	SANITARY
REV	DATE



**CITY OF BEND**

**CITY OF BEND**

STANDARD DRAWING

710 NW WALL ST., BEND, OREGON 97701

**STANDARD SEWER MANHOLE RING & COVER**

SCALE NTS

DATE 01/31/2022

APPR

STD DWG S-3A

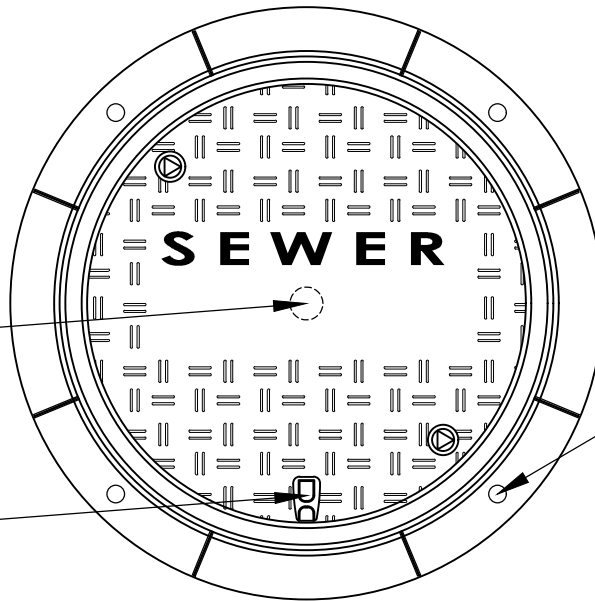

2" DIA SPRUE HOLE  
WITNESS MARK

STAINLESS STEEL  
PICK BAR

SECURE FRAME TO  
MANHOLE/GRADE RINGS  
WITH CONCRETE  
ANCHORS,  
4 MIN

**COMPOSITE COVER/FRAME ASSEMBLY**  
**NTS**

FOR USE IN NON-TRAFFIC AREAS ONLY

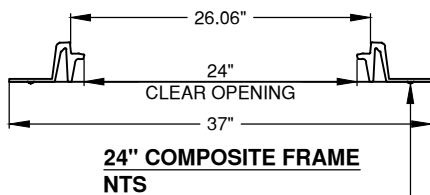
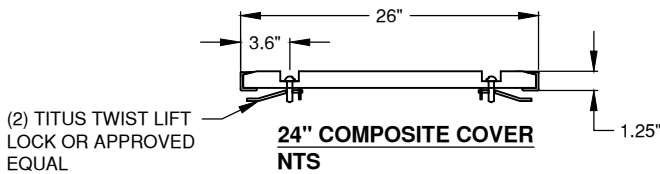

APPLY WATER REPELLANT SEALER AROUND  
ENTIRE FRAME CIRCUMFERENCE PRIOR TO  
TIGHTENING THE CONCRETE ANCHORS.

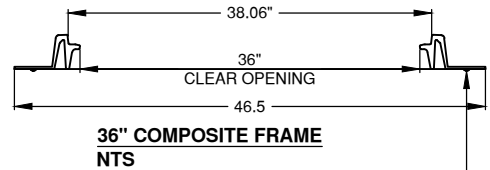
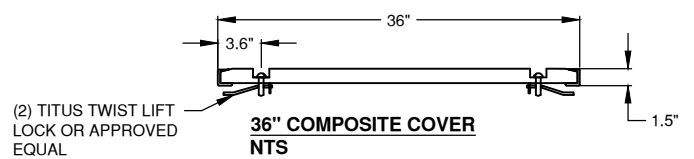

APPLY WATER REPELLANT SEALER AROUND  
ENTIRE FRAME CIRCUMFERENCE PRIOR TO  
TIGHTENING THE CONCRETE ANCHORS.

DRAWN AJD	
DIV SANITARY	
REV	DATE



CITY OF BEND

CITY OF BEND

STANDARD DRAWING

710 NW WALL ST., BEND, OREGON 97701

COMPOSITE MANHOLE FRAME AND COVER

SCALE NTS

DATE 01/31/2022

APPR

STD DWG S-3B

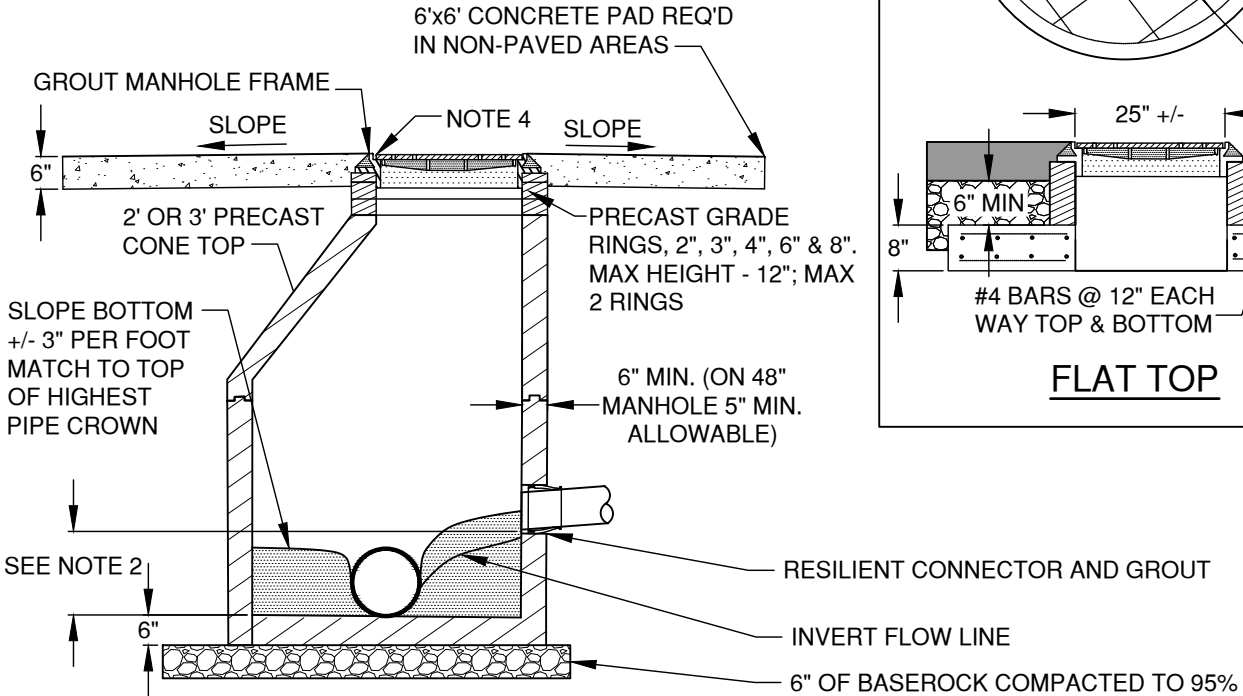
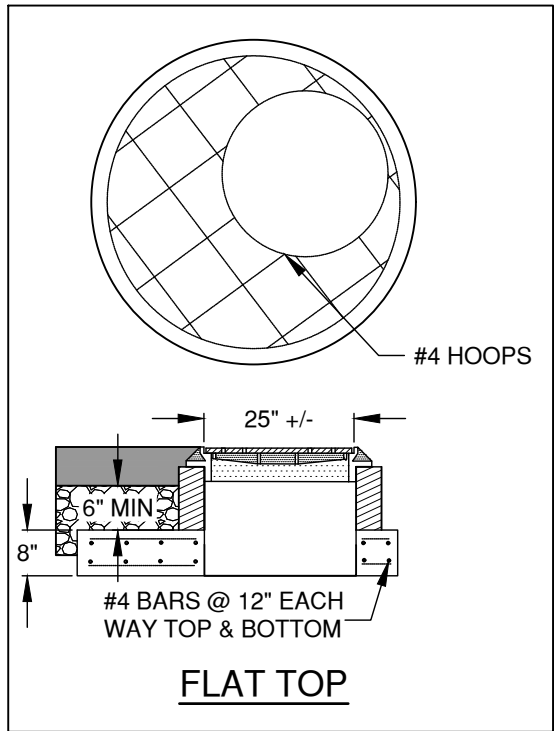
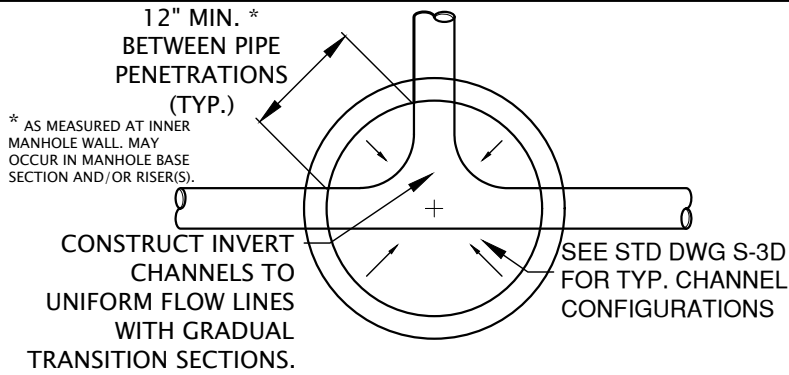

**STANDARD MANHOLE WITH PRECAST BASE**

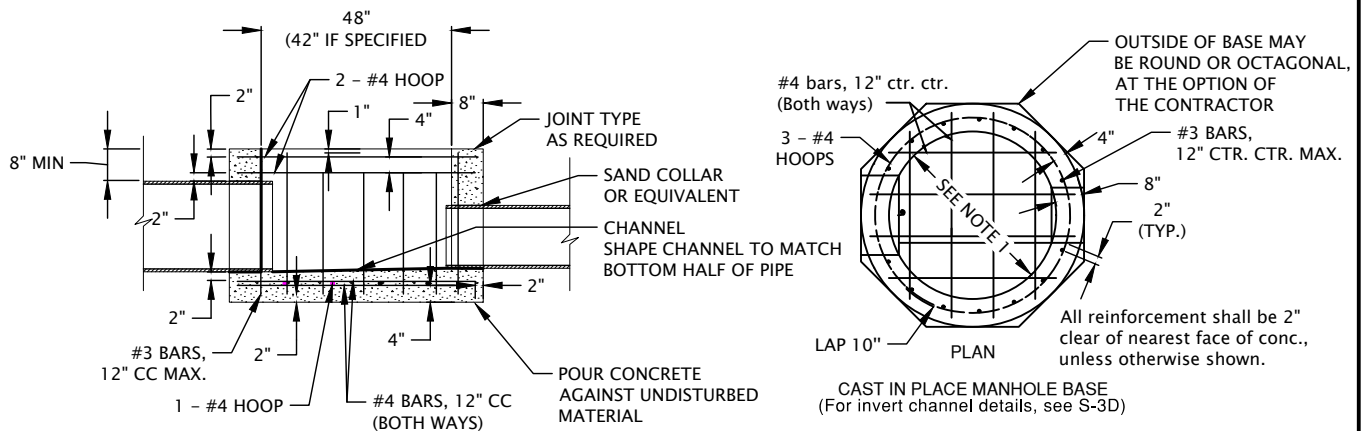

**CAST IN PLACE MANHOLE BASE**

GENERAL NOTES:

1. MANHOLE DIAMETER PER CITY OF BEND DESIGN STANDARDS.
2. THE MAXIMUM INTERNAL DROP IS 1' FOR PIPES 8" IN DIAMETER OR LESS AND 2' FOR PIPES GREATER THAN 8" IN DIAMETER. SEE DWGS S-4 AND S-4A FOR LARGER DROPS.
3. ALL GROUT USED ON MANHOLES SHALL BE NON-SHRINK CONFORMING 02440.50.
4. A SINGLE RISER RING IS ALLOWED ON INITIAL INSTALLATION.
5. PIPE NOT TO PENETRATE PAST MANHOLE WALL MORE THAN 2".

DRAWN	AJD
DIV	SANITARY
REV	DATE



**CITY OF BEND**  
STANDARD DRAWING  
710 NW WALL ST., BEND, OREGON 97701

**STANDARD SEWER/STORM MANHOLE**

SCALE	NTS
DATE	12/09/2025
APPR	
STD DWG	S-3C

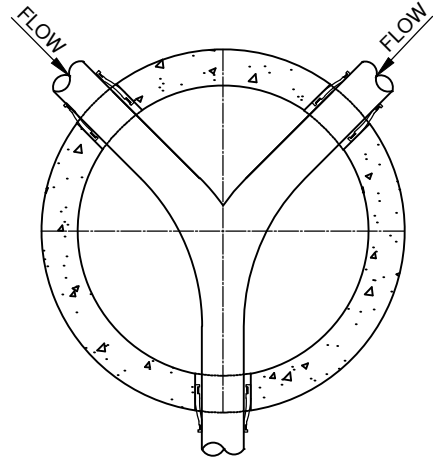
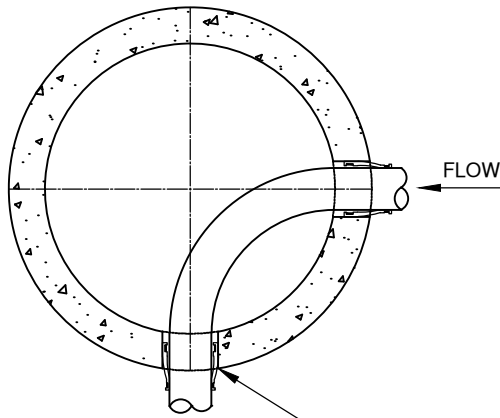

RESILIENT CONNECTOR WITH GROUT FOR PRECAST BASE. SAND COLLAR OR EQUIVALENT IN POURED IN PLACE BASE.

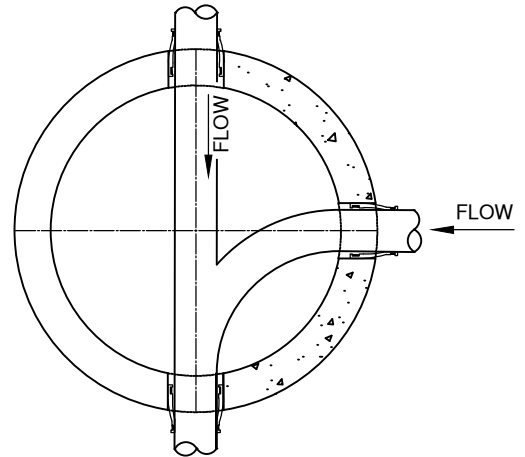
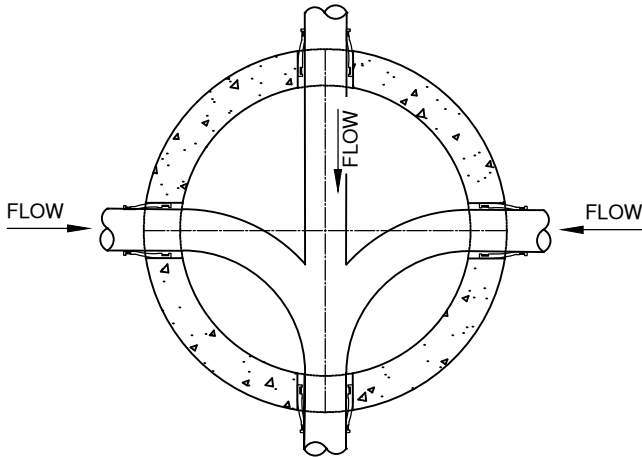

GENERAL NOTES:

1. FLOW CHANNELS DEVIATING FROM THE STANDARD CHANNELS REQUIRE A DETAIL FOR APPROVAL FROM THE ENGINEER
2. WIDTH OF CHANNEL SHOULD MATCH THE INSIDE DIAMETER OF INCOMING AND OUTGOING PIPES.
3. CHANNEL LINING SHALL BE BLENDED FOR SMOOTH CONTOUR BETWEEN PIPES.
4. GROUT CHANNEL TO SMOOTH FINISH.
5. FINISH BOTTOM TO EVEN SLOPE BROOM FINISH TO DRAIN TO CHANNEL.
6. LOCATE MANHOLE OPENING OPPOSITE OUTLET UNLESS OTHERWISE DIRECTED.
7. ALL GROUT USED ON MANHOLES SHALL BE NON-SHRINK CONFORMING 02440.50.

DRAWN AJD	
DIV SANITARY	
REV	DATE



CITY OF BEND

CITY OF BEND

STANDARD DRAWING

710 NW WALL ST., BEND, OREGON 97701

TYPICAL MANHOLE INVERT LAYOUT

SCALE NTS

DATE 11/01/2024

APPR

STD DWG S-3D

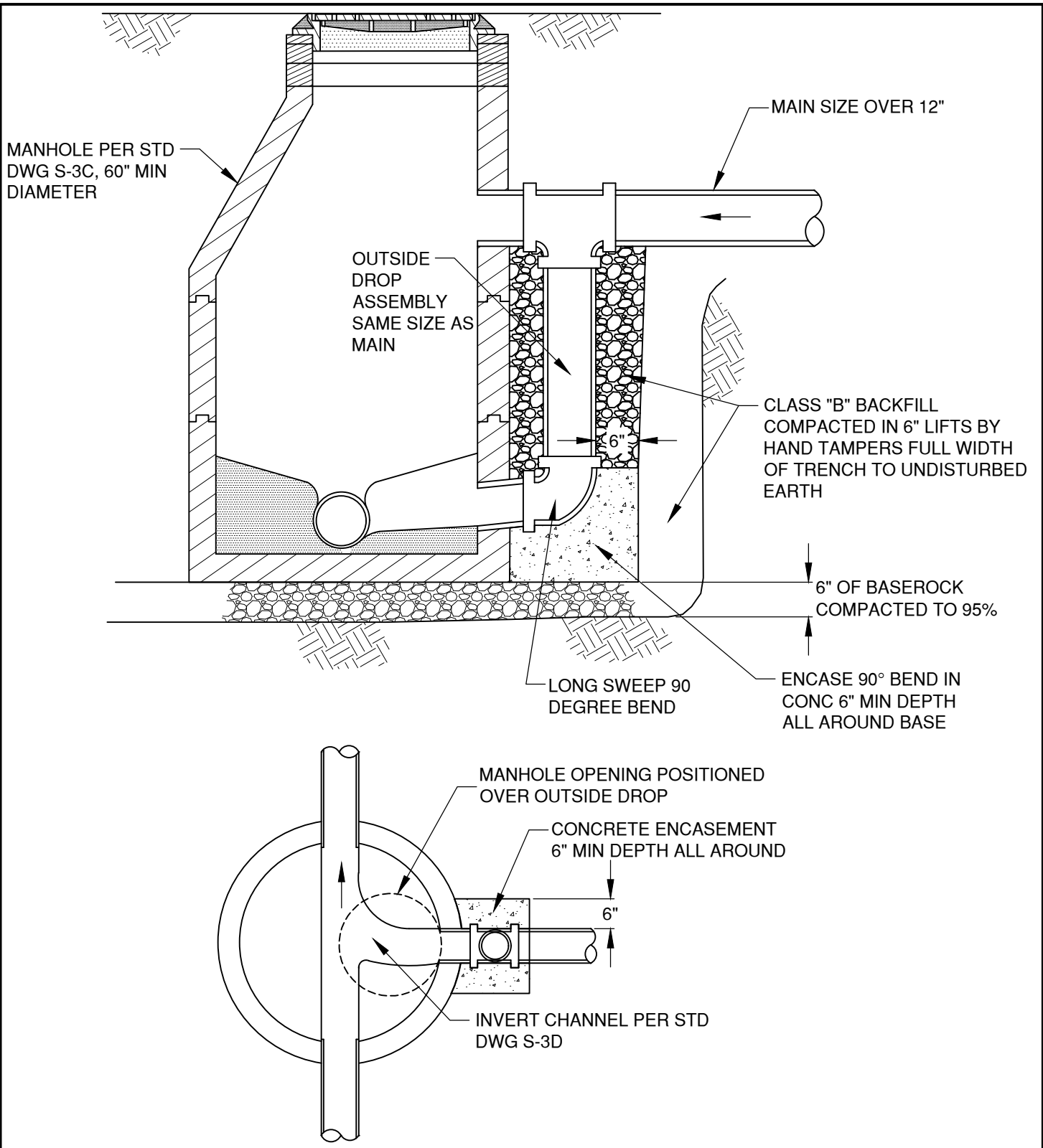

**GENERAL NOTES:**

- 1. OUTSIDE DROP MANHOLE FOR USE WITH MAIN SIZE OVER 12" ONLY

DRAWN AJD	
DIV SANITARY	
REV	DATE



**CITY OF BEND**  
 STANDARD DRAWING  
 710 NW WALL ST., BEND, OREGON 97701

SCALE NTS
DATE 01/31/2022
APPR
STD DWG S-4

**STANDARD OUTSIDE DROP - LARGER THAN 12" PIPE**

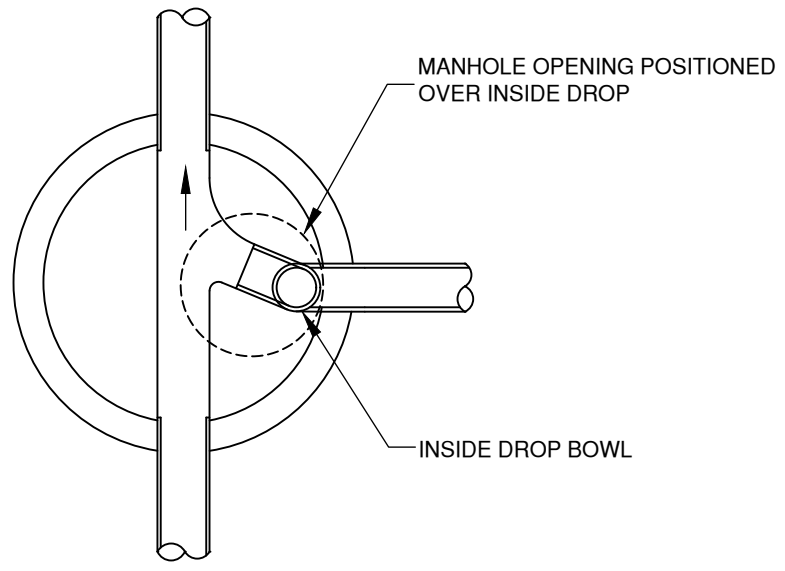
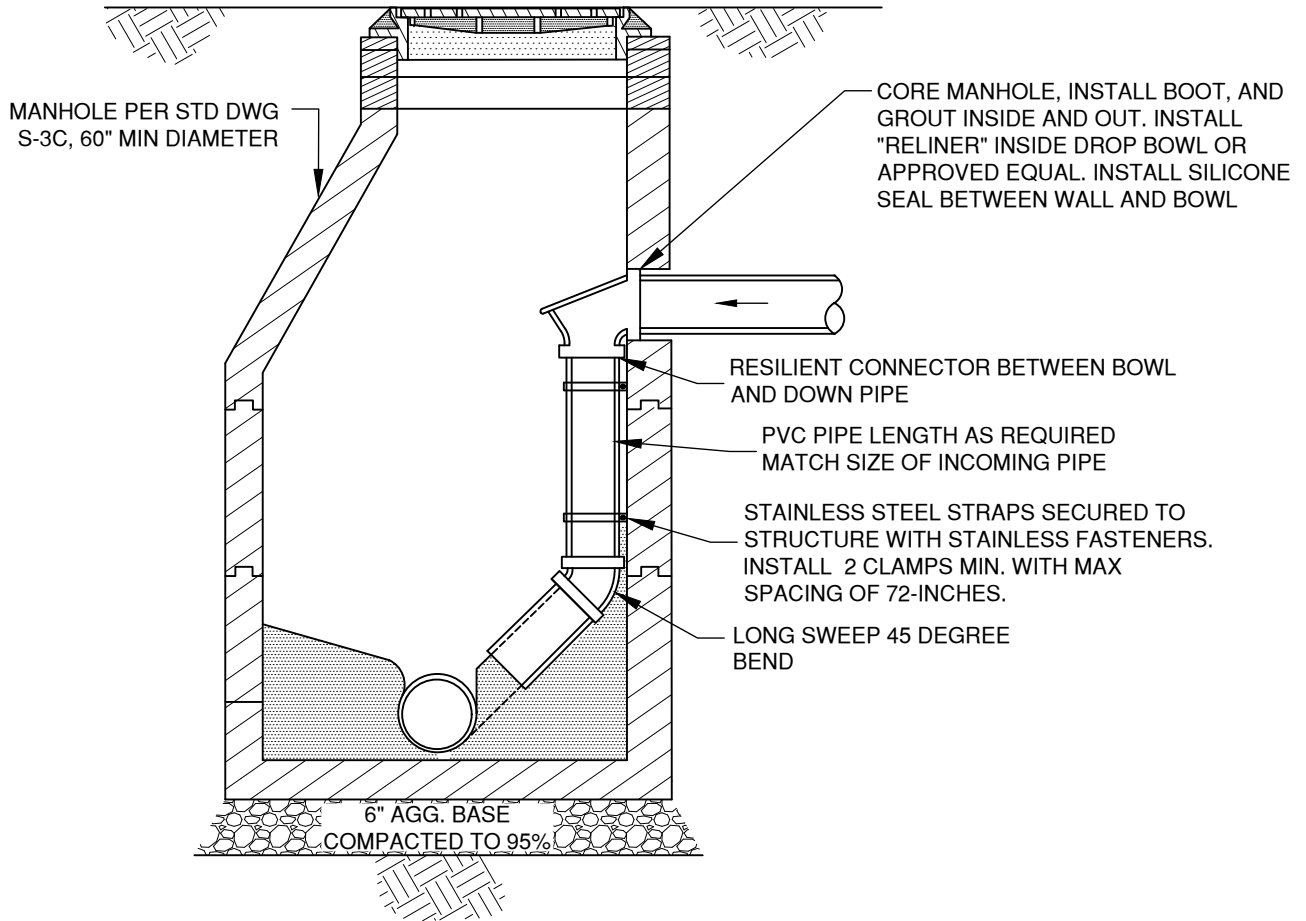

**NOTES:**

1. INSIDE DROP MANHOLE FOR USE WITH MAIN SIZE 12" AND SMALLER ONLY

DRAWN CJH		 <b>CITY OF BEND</b>	<b>CITY OF BEND</b> STANDARD DRAWING 710 NW WALL ST., BEND, OREGON 97701	SCALE NTS
DIV SANITARY				DATE 04/16/2026
REV	DATE			APPR
		<b>CITY OF BEND</b>	<b>STANDARD INSIDE DROP - 12" PIPE AND SMALLER</b>	STD DWG S-4A

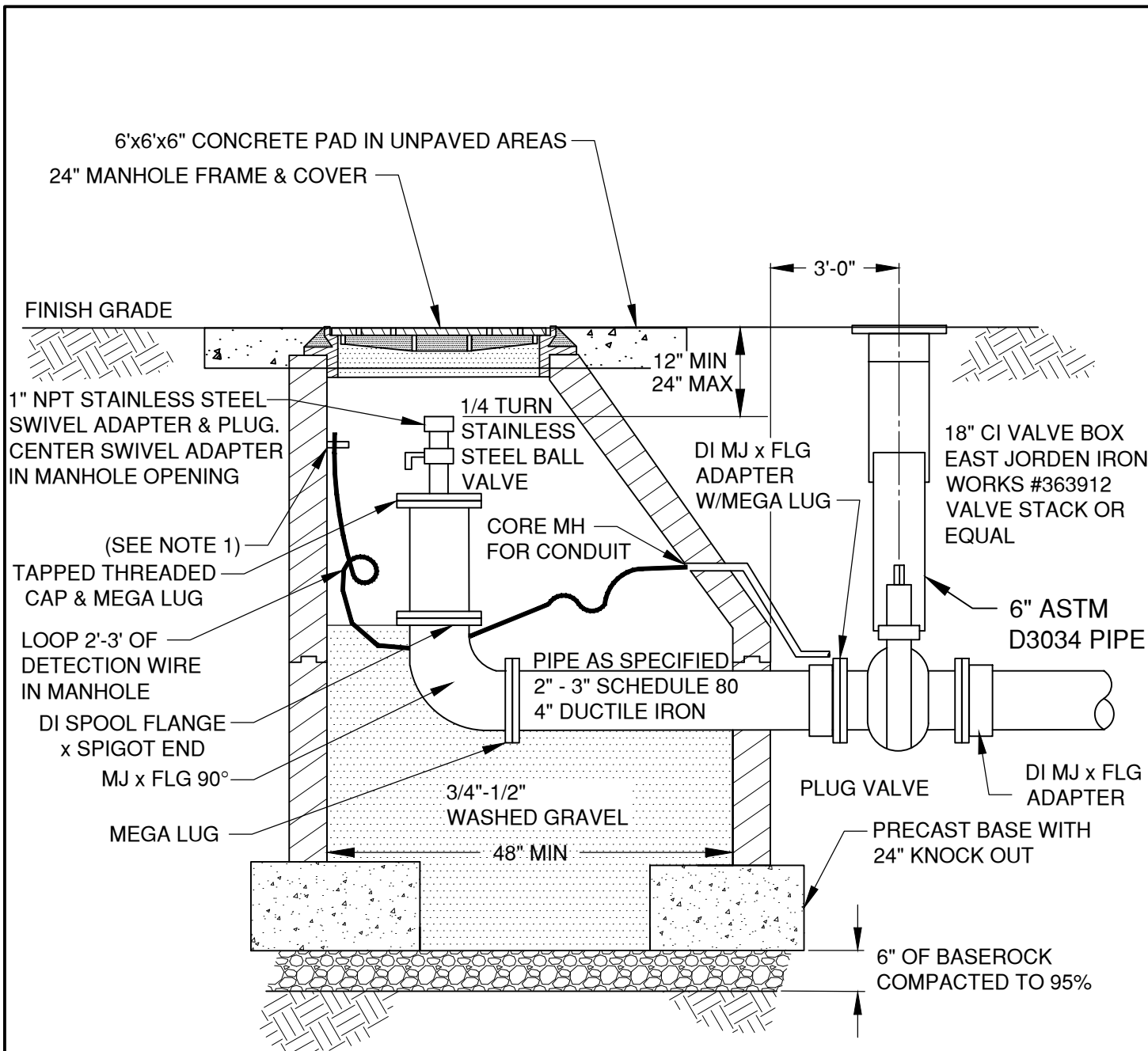

NOTES:

1. TRACER WIRE SHALL BE EXTENDED WITHIN 18-INCHES OF FINISHED GRADE OR 6" BELOW LOWEST GRADE RING, WHICH EVER IS GREATER, TO A 1.75-INCH STAINLESS STEEL RUBBER CUSHIONED CLAMP MOUNTED TO MANHOLE WITH AS MIN 1/4" X 1-3/4" CONCRETE ANCHOR SCREW.

DRAWN AJD	
DIV SANITARY	
REV	DATE



CITY OF BEND

CITY OF BEND

STANDARD DRAWING

710 NW WALL ST., BEND, OREGON 97701

3" & 4" PRESSURE SEWER LINE TERMINATION CLEANOUT

SCALE NTS

DATE 01/31/2022

APPR

STD DWG S-5





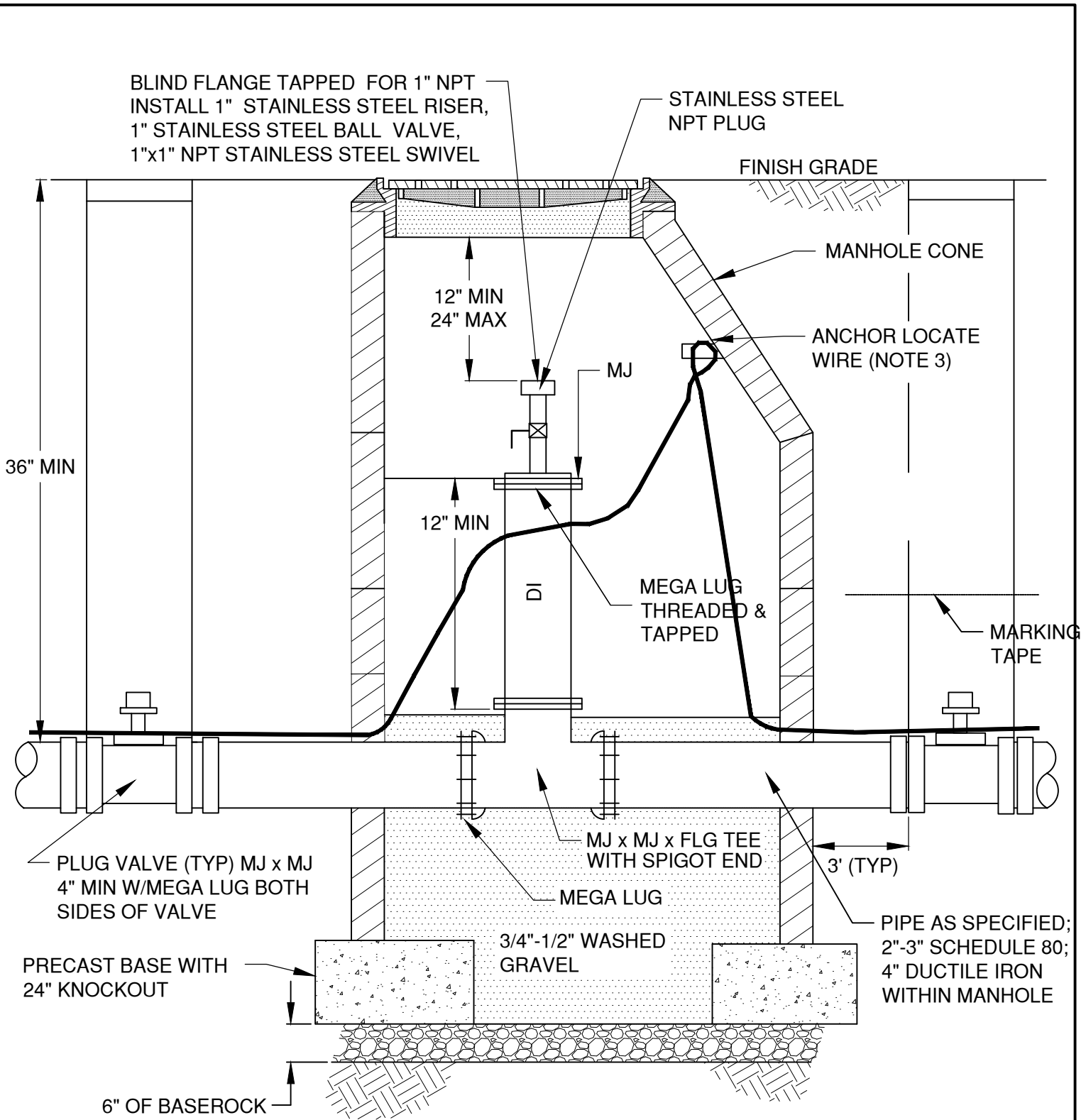

NOTE:

6" OF BASEROCK  
COMPACTED TO 95%

1. ALL DUCTILE IRON FITTINGS THROUGH MANHOLE
2. 48" MINIMUM DIAMETER MANHOLE
3. TRACER WIRE SHALL BE EXTENDED WITHIN 18-INCHES OF FINISHED GRADE OR 6" BELOW LOWEST GRADE RING, WHICH EVER IS GREATER, TO A 1.75-INCH STAINLESS STEEL RUBBER CUSHIONED CLAMP MOUNTED TO MANHOLE WITH AS MIN 1/4" X 1-3/4" CONCRETE ANCHOR SCREW.

DRAWN AJD	
DIV SANITARY	
REV	DATE



CITY OF BEND

CITY OF BEND

STANDARD DRAWING

710 NW WALL ST., BEND, OREGON 97701

MAIN LINE CLEANOUT PRESSURE SEWER

SCALE NTS

DATE 01/31/2022

APPR

STD DWG S-7

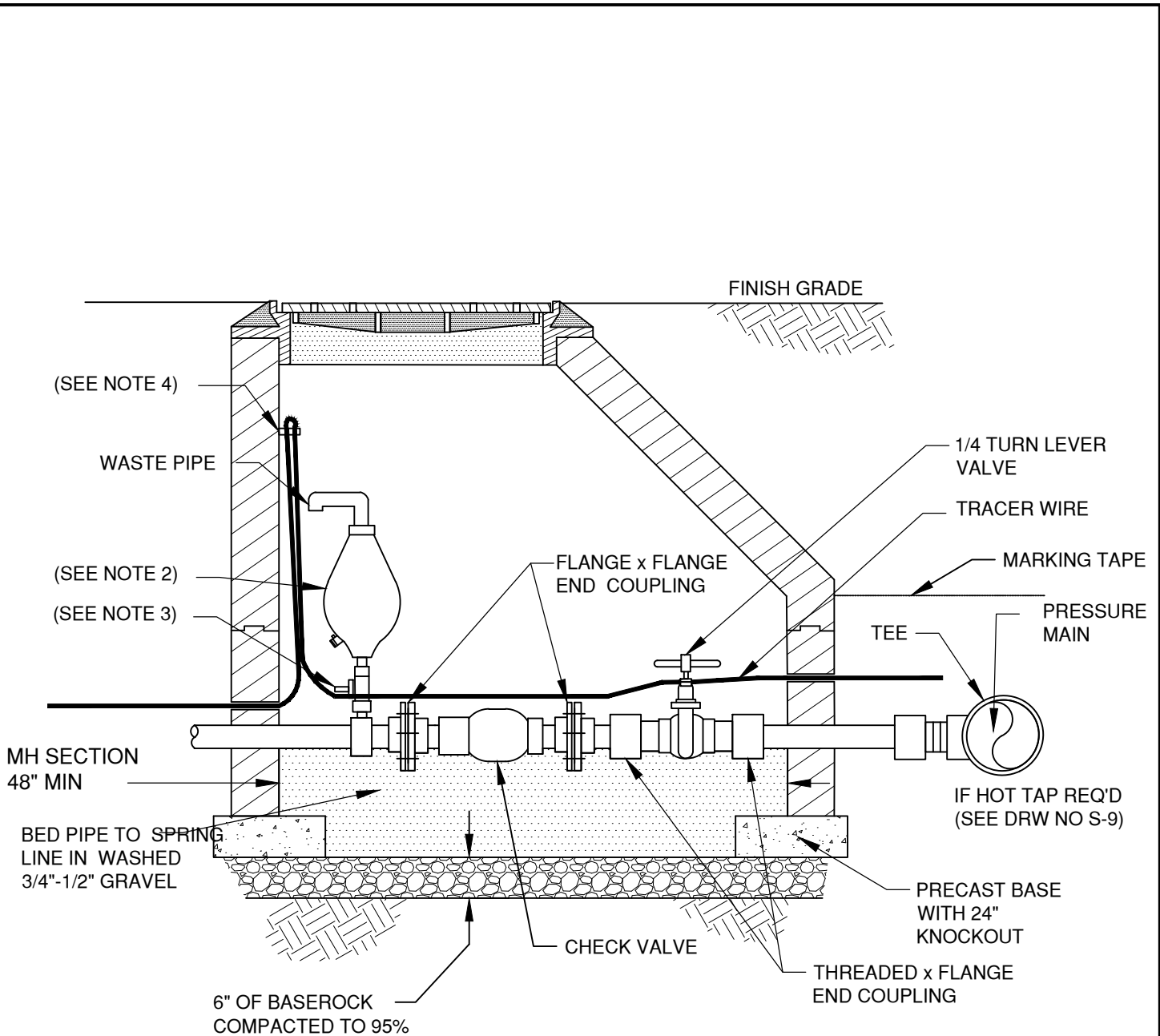

**TYPICAL INSTALLATION IN TRAFFIC AREA**

- NOTE:
1. SHOWN WITH PLUG VALVE IN ENCLOSURE
  2. 2" COMBINATION AIR VALVE (SHORT VERSION) PER. 00445.11(l)(2)(d)
  3. 2" STAINLESS STEEL BALL VALVE
  4. TRACER WIRE SHALL BE EXTENDED WITHIN 18-INCHES OF FINISHED GRADE OR 6" BELOW LOWEST GRADE RING, WHICH EVER IS GREATER, TO A 1.75-INCH STAINLESS STEEL RUBBER CUSHIONED CLAMP MOUNTED TO MANHOLE WITH AS MIN 1/4" X 1-3/4" CONCRETE ANCHOR SCREW.

DRAWN AJD	
DIV SANITARY	
REV	DATE



**CITY OF BEND**  
 STANDARD DRAWING  
 710 NW WALL ST., BEND, OREGON 97701

---

**PRESSURE SEWER SERVICE - TRAFFIC AREA**

SCALE NTS
DATE 01/31/2022
APPR
STD DWG S-8

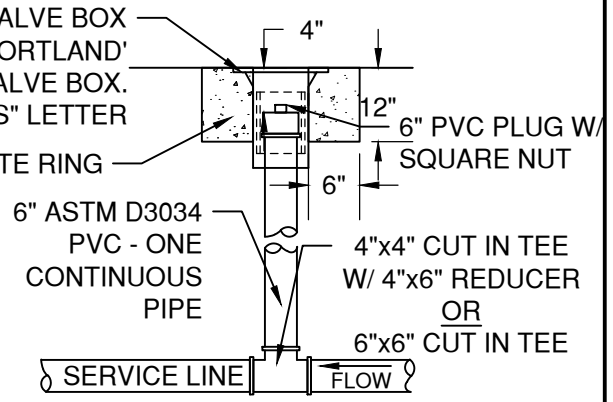
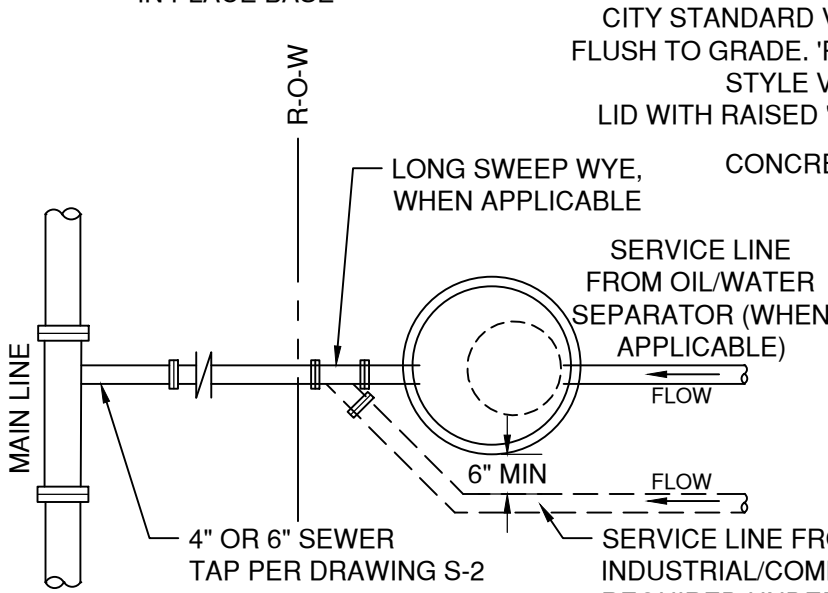
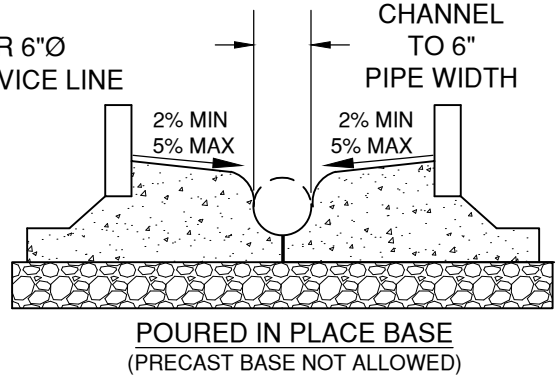
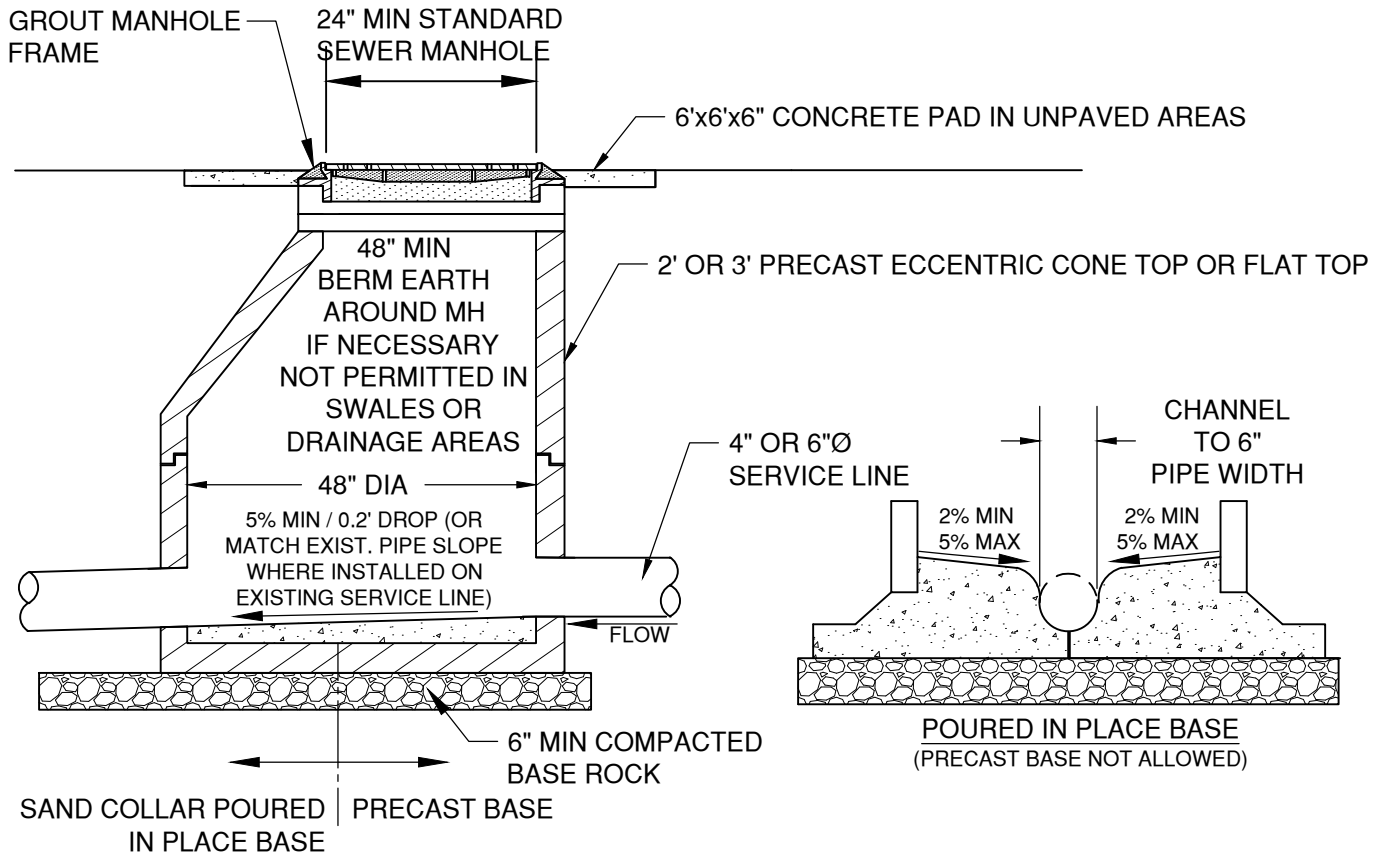

**SAMPLING TEE OPTION**  
PROFILE VIEW (NOTE 3)

**NOTES:**

1. MULTIPLE SERVICE LINES SHALL CONNECT UPSTREAM AND OUTSIDE THE SAMPLE MANHOLE
2. SAMPLE MANHOLE TO BE LOCATED ON PRIVATE PROPERTY IN AN ACCESSIBLE AREA.
3. SAMPLING TEE OPTION IS ONLY PERMITTED WHEN APPROVED BY THE CITY ENGINEER AND ARE INTENDED FOR RETROFITS ON EXISTING SYSTEMS ONLY. CONSIDERED IN SITUATIONS WHERE EXISTING UTILITIES OR EASEMENTS PREVENT THE INSTALLATION OF MANHOLE.

DRAWN AJD	
DIV SANITARY	
REV	DATE



**CITY OF BEND**  
STANDARD DRAWING  
710 NW WALL ST., BEND, OREGON 97701

**INDUSTRIAL AND COMMERCIAL SERVICES SAMPLING MH**

SCALE NTS
DATE 01/31/2022
APPR
STD DWG S-15

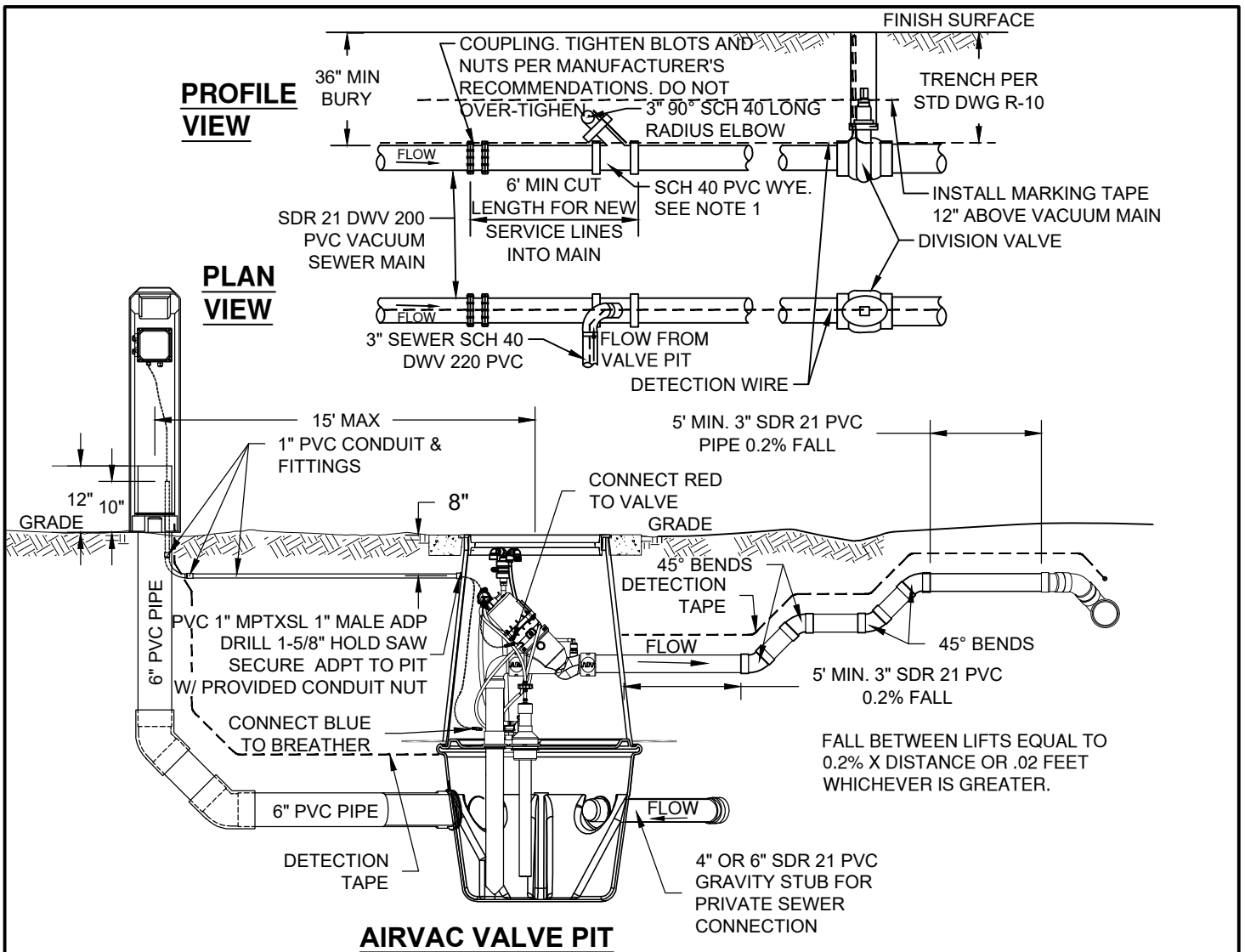

**NOTE:**

1. ALL WORK DONE ON A VACUUM SEWER SHALL BE COORDINATED WITH PUBLIC WORKS 7 DAYS IN ADVANCE TO COORDINATE VACUUM STATION SHUT DOWN.
2. ALL JOINTS TO BE CONNECTED USING STANDARD PRIMER AND SOLVENT CEMENT. KEEP ALL JOINTS CLEAN AND FREE OF DEBRIS. JOINTS TO BE SCH40 DWV 220 OR APPROVED EQUAL.
3. AFTER INSTALLATION IS COMPLETE, OPEN DIVISION VALVE AND PERFORM VISUAL AND AUDIBLE INSPECTION OF EACH JOINT FOR LEAKS PRIOR TO TRENCH CLOSURE.
4. TRENCH BACKFILL TO BE IN ACCORDANCE TO S-1. MARKING TAPE AND TRACER WIRE TO BE INSTALLED ON ALL MAINS AND SERVICES.
5. INSTALL GRAVITY SEWER LATERALS IN CONFORMANCE WITH PLUMBING CODE. SERVICE LINE FROM THE PIT TO THE HOUSE IS OWNED AND MAINTAINED BY PROPERTY OWNER. CONNECTIONS TO THE AIRVAC VALVE PIT SHALL BE MADE AS PER MANUFACTURER'S SPECIFICATION.
6. AIR-INTAKE SHALL BE INSTALLED IN CONFORMANCE TO THE PLUMBING CODE AND SHALL BE PERMITTED WITH THE BUILDING DEPARTMENT UNDER A PLUMBING PERMIT.
7. PIT TO BE INSTALLED OUTSIDE OF SIDEWALK AND APRON SURFACES IN ROW OR CITY EASEMENT.
8. ALL WORK SHALL CONFORM TO AIR VAC SPECIFICATIONS. NO MORE THAN TWO SERVICES MAY CONNECT TO A ONE VACCUM PIT.
9. CONNECTION AVAILABILITY TO VALVE PIT TO BE DETERMINED BY THE CITY ENGINEER BASED ON MANUFACTURERS ALLOWABLE FLOW INTO PIT AND THE VACUUM SYSTEM.

DRAWN CJH	
DIV SANITARY	
REV	DATE



**CITY OF BEND**

**CITY OF BEND**

STANDARD DRAWING

710 NW WALL ST., BEND, OREGON 97701

**VACUUM SEWER SERVICE**

SCALE NTS

DATE 11/01/2024

APPR

STD DWG S-16

---

**CITY OF BEND STANDARD DRAWINGS**  
**Stormwater (STRM)**

---

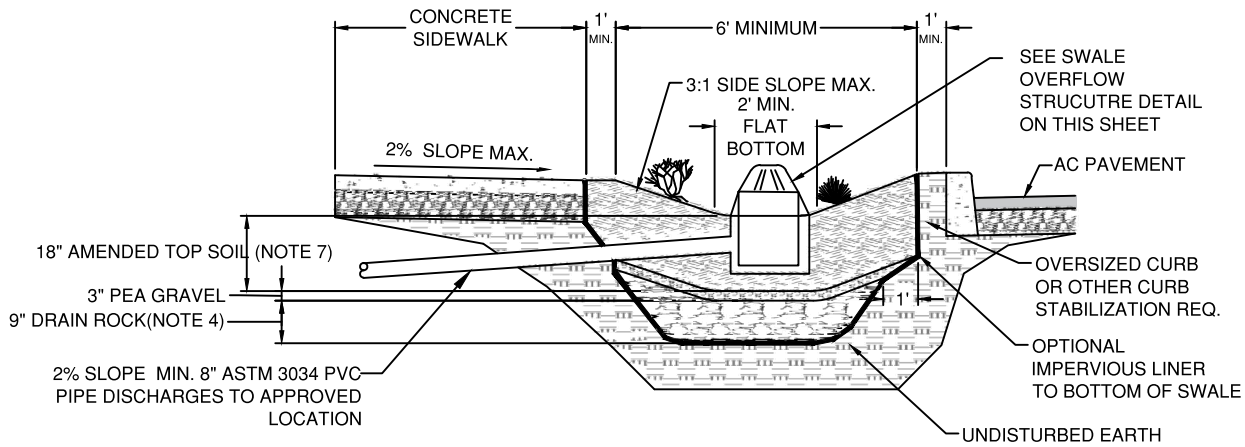

**VEGETATED SWALE WITH OPTIONAL ROCK STORAGE RESERVOIR**

NTS

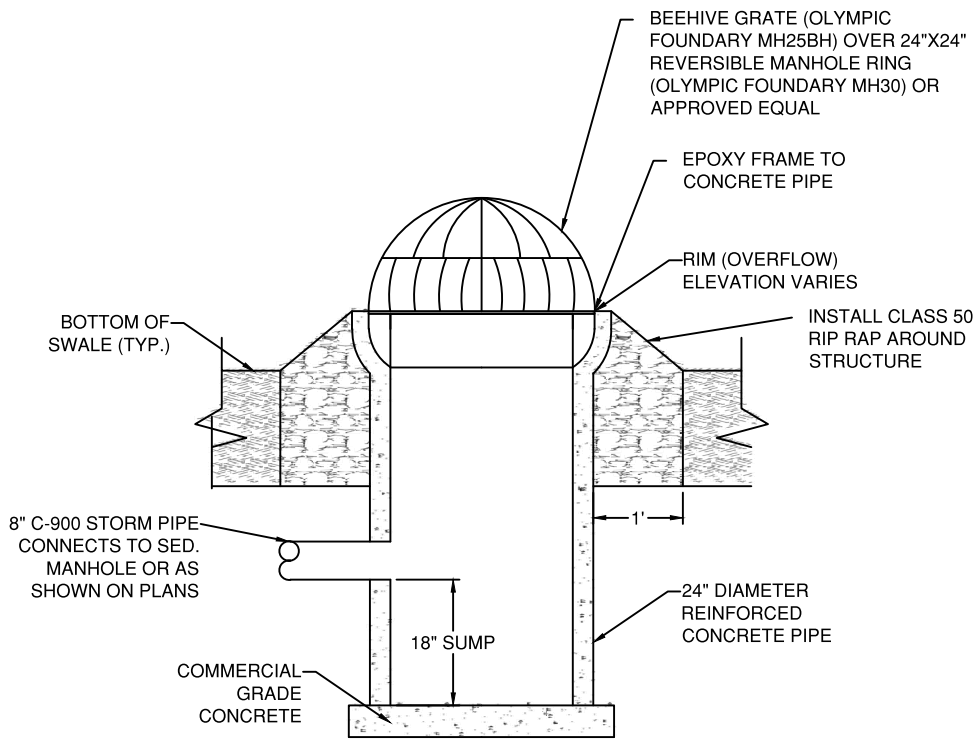

**SWALE OVERFLOW STRUCTURE**

NTS

**NOTES:**

1. AMENDED TOPSOIL SHALL CONTAIN 20-30% TOPSOIL, 50-65% CLEAN SAND AND 5-20% COMPOST OR PEAT MOSS.
2. VOLUME AND DEPTH TO BE DETERMINED BY ENGINEER.
3. DRAIN ROCK AS REQUIRED FOR DRAINAGE CAPACITY. PEA GRAVEL TO BE USED TO PREVENT SOIL MIGRATION INTO DRAINAGE LAYER.
4. OPTIONAL ROCK RESERVOIR TO BE CONSTRUCTED WITH WASHED DRAIN ROCK WITH 40% VOIDS. NOT TO BE USED IN TREE WELLS.
5. AVOID COMPACTING SWALE AREA DURING CONSTRUCTION.
6. ADD HIGH POINT FLOW BYPASS TO AN APPROVED DISPOSAL POINT AS NECESSARY. OVERFLOW SHOULD PASS THROUGH A SEDIMENTATION MANHOLE OR PRE-TREATMENT PRIOR TO DISCHARGING TO A DRYWELL OR UIC.
7. AMENDED TOP SOIL CAN BE REPLACED WITH DRAIN ROCK FOR ROCK SWALES. ROCK SWALES CANNOT BE USED TO MEET PRETREATMENT REQUIREMENTS.
8. INSTALL CHECK DAMS AS REQUIRED AND PER DWG STRM-4.

DRAWN A.JD	
DIV STORM	
REV	DATE



**CITY OF BEND**  
STANDARD DRAWING  
710 NW WALL ST., BEND, OREGON 97701

**VEGETATED SWALE DETAIL**

SCALE NTS
DATE 01/31/2022
APPR
STD DWG STRM-2

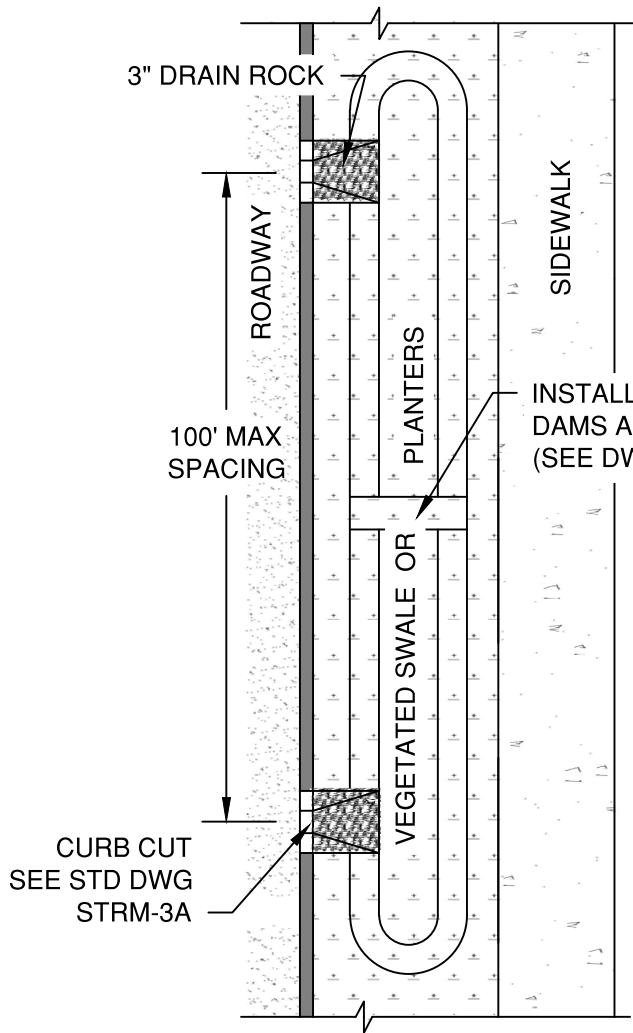

VEGETATED SWALE/ PLANTER  
NTS

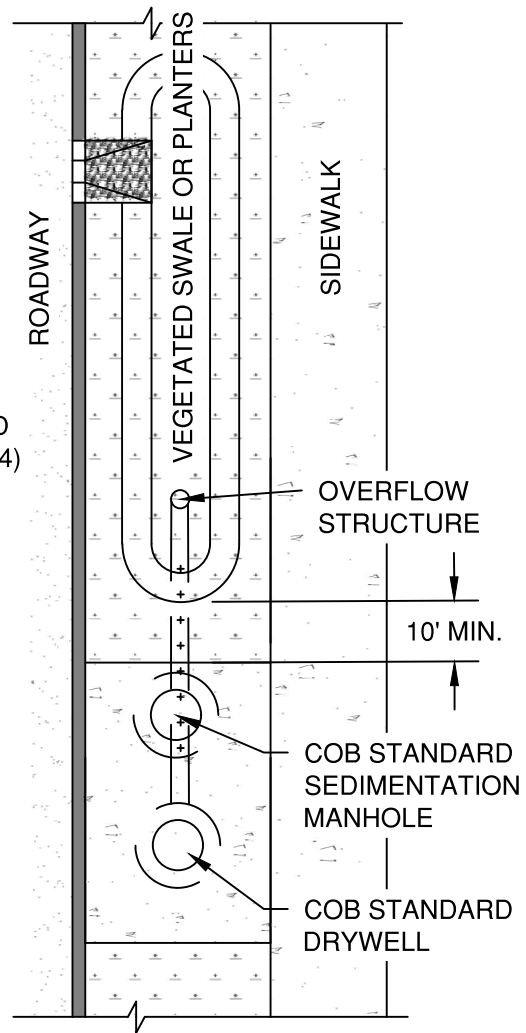

VEGETATED SWALE/ PLANTERS  
W/ DRYWELL OVERFLOW  
NTS

NOTES:

1. SWALE/SURFACE INFILTRATION FACILITIES NOT PERMITTED WITHIN PUES OR OVER FRANCHISE UTILITIES
2. VOLUME AND DEPTH TO BE DETERMINED BY ENGINEER.

DRAWN AJD	
DIV STORM	
REV	DATE



**CITY OF BEND**  
STANDARD DRAWING  
710 NW WALL ST., BEND, OREGON 97701

**TYPICAL SWALE LAYOUT**

SCALE NTS
DATE 01/31/2022
APPR
STD DWG STRM-3

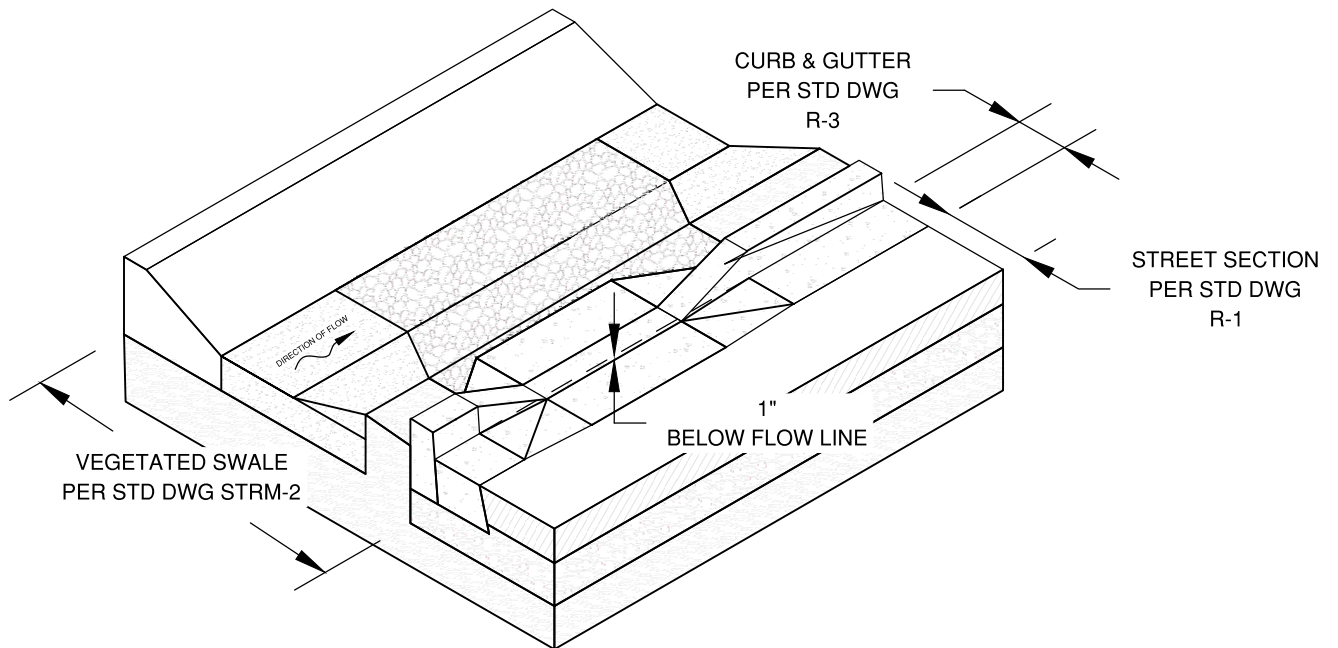
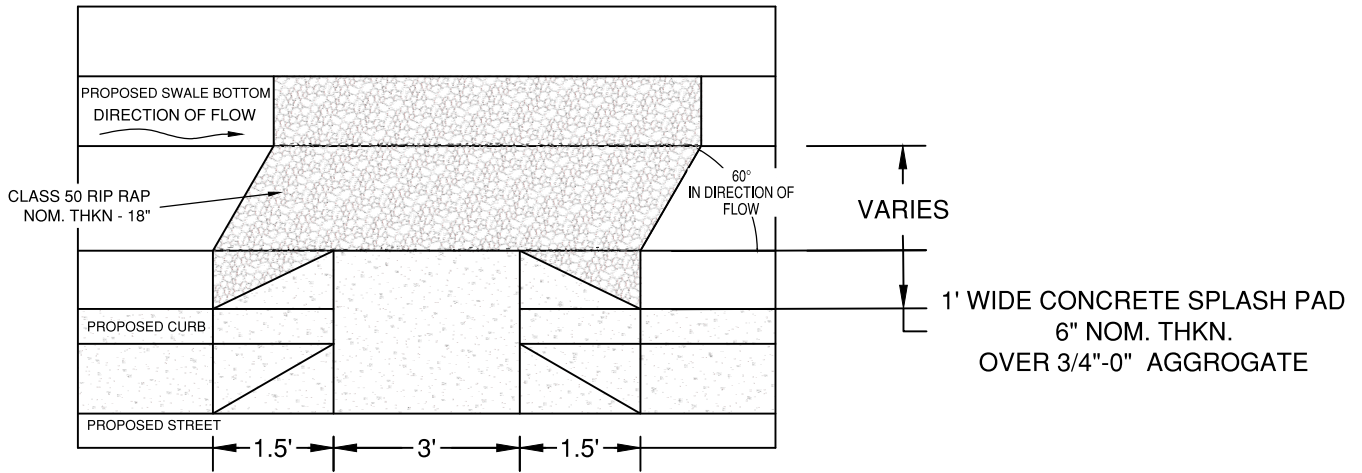

DRAWN AJD  
DIV STORM  
REV DATE



CITY OF BEND

CITY OF BEND

STANDARD DRAWING

710 NW WALL ST., BEND, OREGON 97701

TYPICAL CURB CUT

SCALE NTS

DATE 01/31/2022

APPR

STD DWG STRM-3A

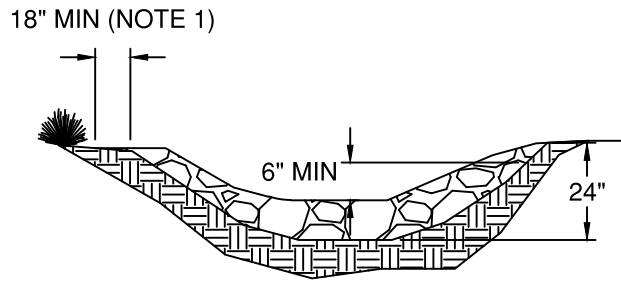

**CHANNEL CROSS SECTION**

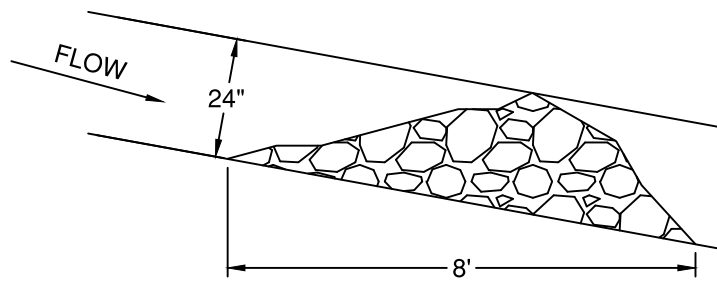

**CHECK DAM PROFILE**

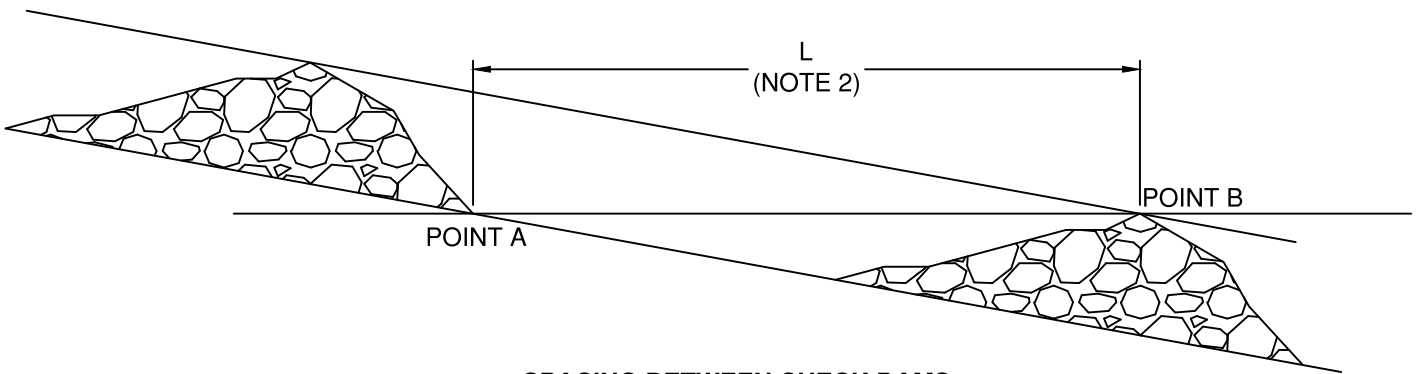

**SPACING BETWEEN CHECK DAMS**

**NOTES:**

1. KEY STONE INTO THE CHANNEL BANKS AND EXTEND DAM A MINIMUM OF 18" TO PREVENT FLOW AROUND DAM.
2. L IS EQUAL TO THE DISTANCE SUCH THAT 'POINT A' AND 'POINT B' ARE OF EQUAL ELEVATION.
3. CHECK DAMS SHALL BE INSTALLED PER CENTRAL OREGON STORMWATER MANUAL (COSM) REQUIREMENTS.

DRAWN LJC	
DIV STORM	
REV	DATE



CITY OF BEND

**CITY OF BEND**

STANDARD DRAWING

710 NW WALL ST., BEND, OREGON 97701

**CHECK DAM DETAIL**

SCALE NTS

DATE 12/1/17

APPR

STD DWG STRM-4

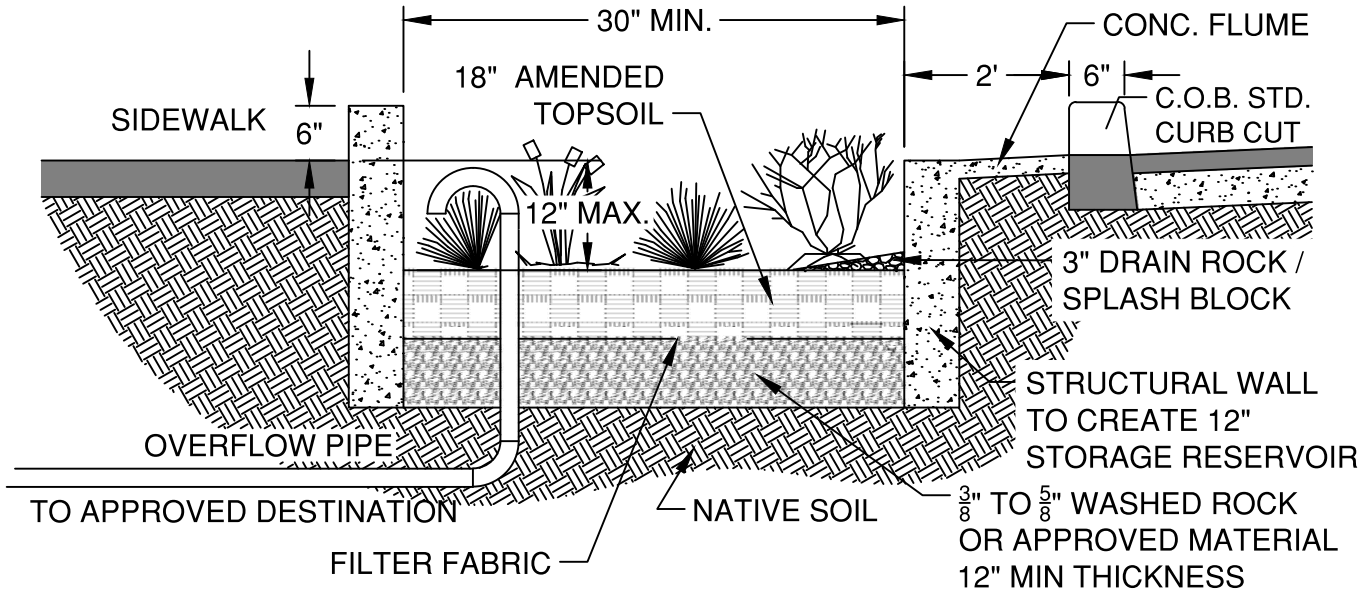

INFILTRATION PLANTER TYPICAL SECTION

NTS

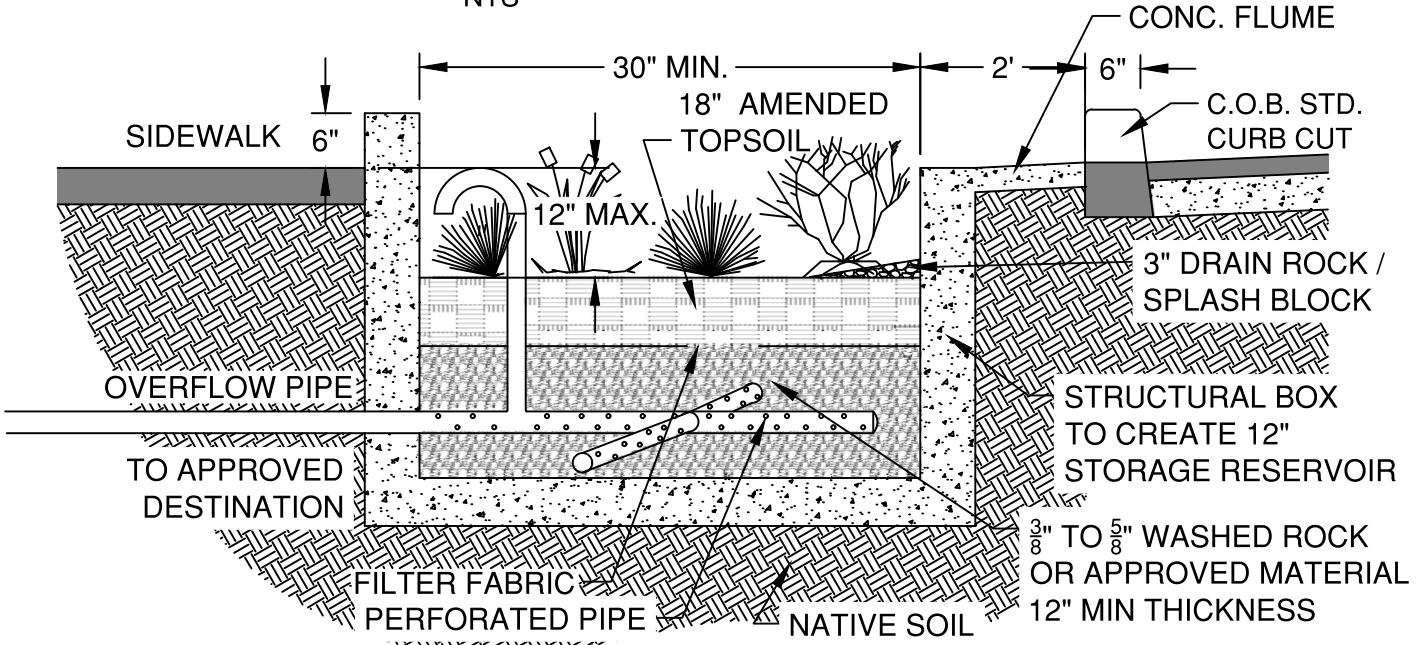

FLOW-THROUGH PLANTER TYPICAL SECTION

NTS

NOTE:

1. NOT FOR USE ALONG STREETS WITH POSTED SPEED ABOVE 25 MPH, UNLESS OUTSIDE THE CLEAR ZONE.
2. AMENDED TOPSOIL PER SPECIFICATION 01040
3. VOLUME AND DEPTH TO BE DETERMINED BY ENGINEER.
4. USE INFILTRATION PLANTER IF EXISTING SITE HAS AN INFILTRATION RATES > 0.5 IN/HR.
5. PLACE OVERFLOW PIPE 2" BELOW TOP OF PLANTER.
6. TO AVOID UIC REGULATION DO NOT USE PERFORATED PIPE OUTSIDE OF THE FLOW-THROUGH PLANTER OR WITH THE INFILTRATION PLANTER.

DRAWN	AJD
DIV	STORM
REV	DATE



CITY OF BEND

CITY OF BEND  
STANDARD DRAWING

710 NW WALL ST., BEND, OREGON 97701

STORMWATER PLANTER DETAIL

SCALE	NTS
DATE	01/31/2022
APPR	
STD DWG	STRM-5

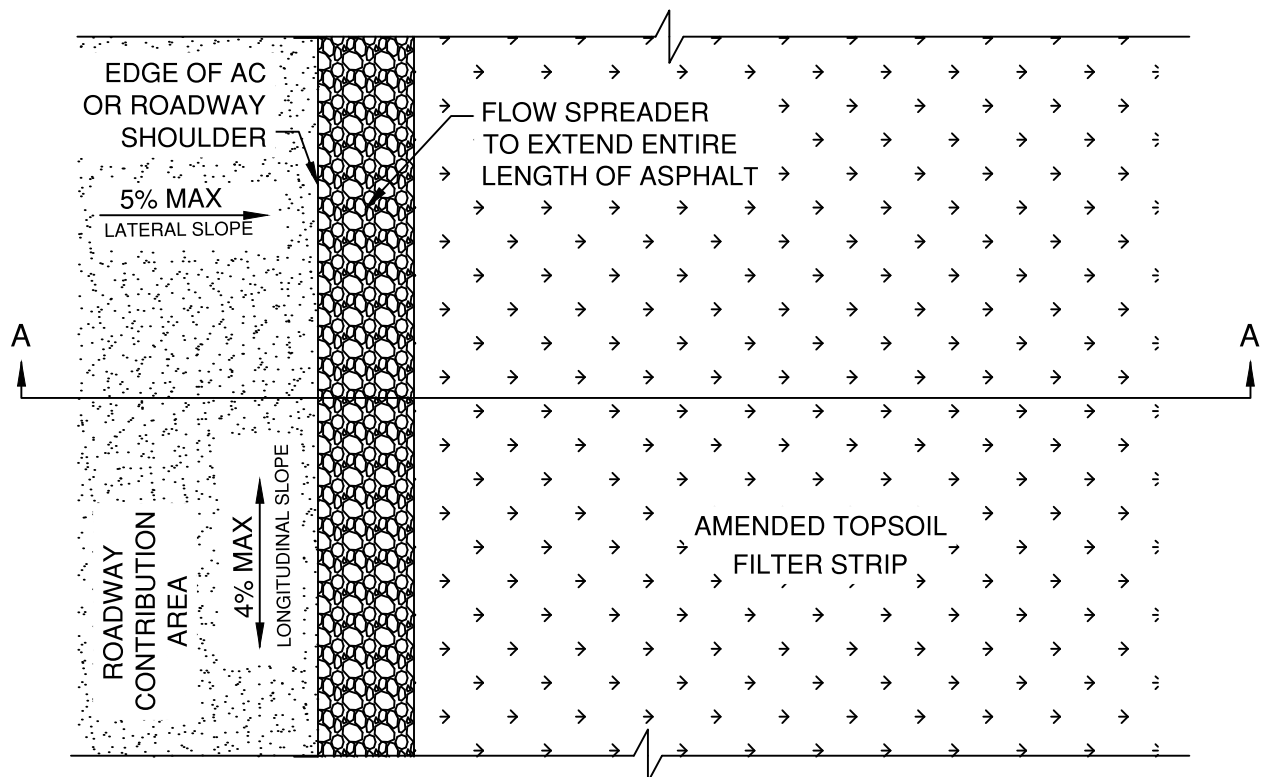

PLAN VIEW  
NTS

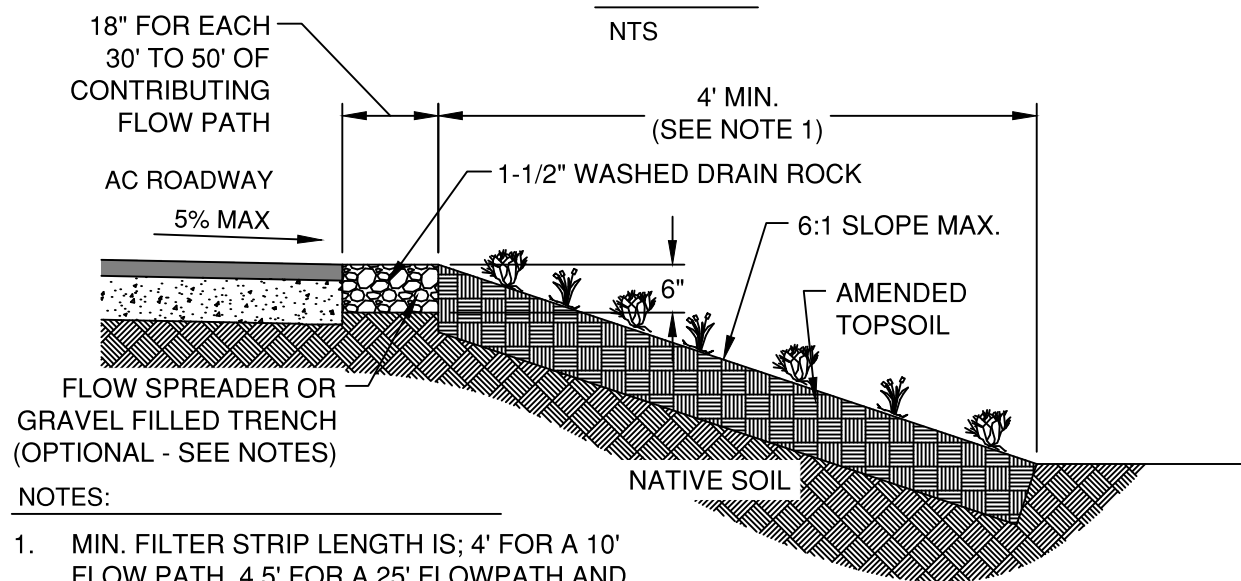

SECTION A-A  
NTS

- NOTES:
1. MIN. FILTER STRIP LENGTH IS; 4' FOR A 10' FLOW PATH, 4.5' FOR A 25' FLOWPATH AND 5.5' FOR A 30' FLOWPATH
  2. AMENDED TOPSOIL PER SPECIFICATION 01040
  3. FLOW SPREADER IS OPTIONAL. IF USED THE GRAVEL MUST BE WIDER THAN DEEP TO AVOID UIC REGULATIONS.

DRAWN AJD  
DIV STORM  
REV DATE



CITY OF BEND

CITY OF BEND  
STANDARD DRAWING

710 NW WALL ST., BEND, OREGON 97701

STORMWATER FILTER DETAIL

SCALE NTS  
DATE 01/31/2022  
APPR  
STD DWG STRM-6

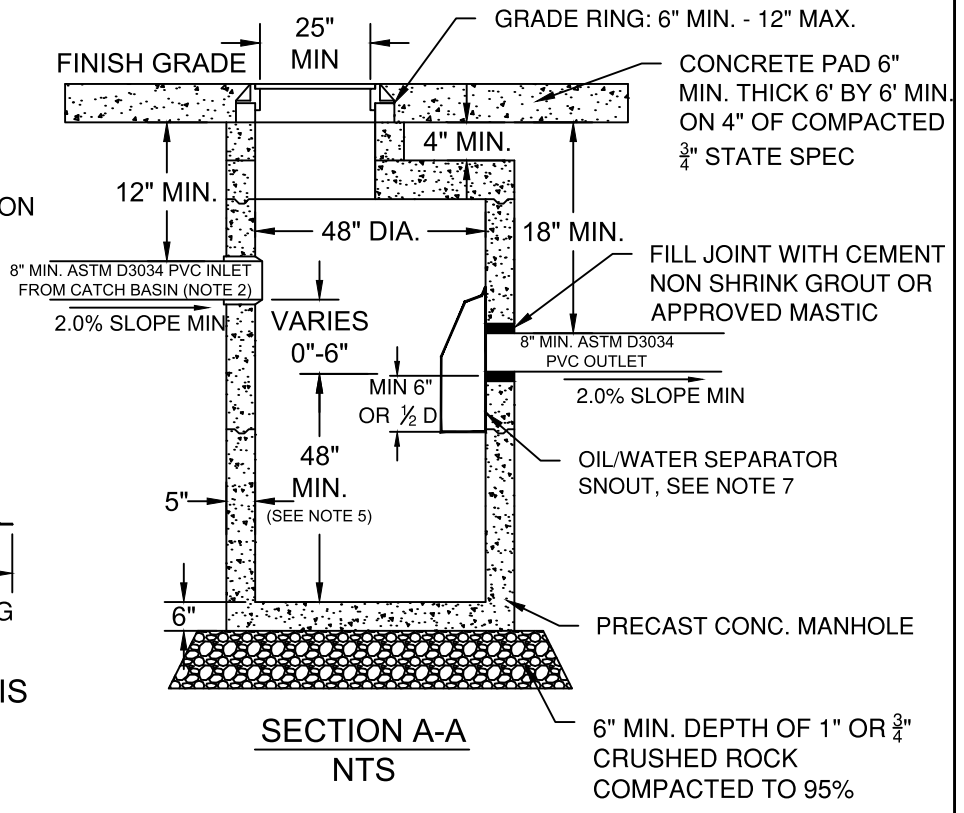
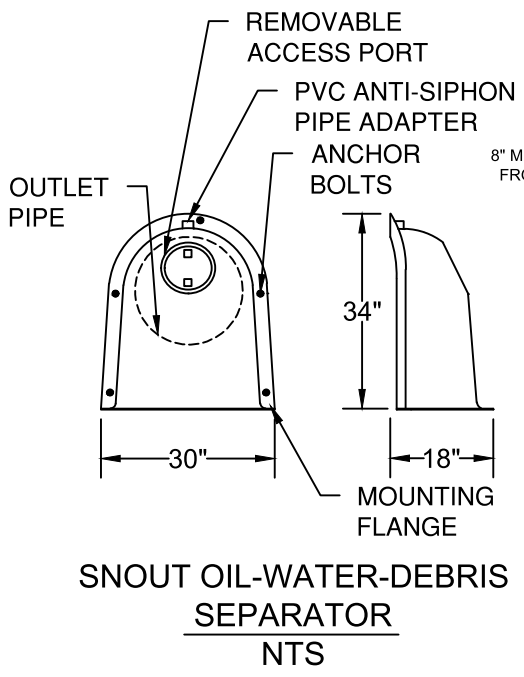
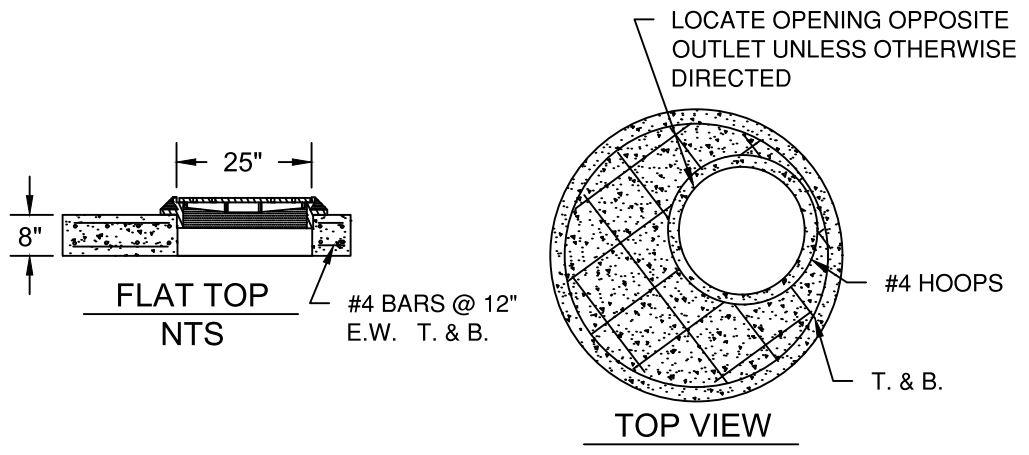

- NOTES:
1. ALL PRE-CAST SECTIONS SHALL CONFORM TO REQUIREMENTS OF ASTM C-478.
  2. AWWA C900 PIPE SHALL BE USED WITHIN TRAVEL AREAS. ASTM D3034 PIPE WHERE STORM PIPE WILL BE INSTALLED PERSANITARY SEWER REQUIREMENTS OR OUTSIDE OF TRAVEL AREAS.
  3. MANHOLES SHALL BE PLACED OUTSIDE SIDEWALK, APRONS & STREET SURFACES UNLESS APPROVED BY THE CITY ENGINEER.
  4. A 3 POINT MECHANICAL ADJUSTMENT SYSTEM SUCH AS RAD'S OR APPROVED EQUAL SHALL BE USED TO ADJUST MANHOLE FRAME AND COVER TO FINISH GRADE.
  5. SUMP SIZE TO BE DESIGNED IN ACCORDANCE WITH COSM - 20 CF OF SUMP VOLUME FOR EACH 1.0 CFS DESIGN FLOW - NOT LESS THAN 48" DEPTH.
  6. MANHOLES WITH MORE THAN 3 CONNECTIONS, OR PIPES 12" OR LARGER TO BE 60" MANHOLES
  7. OIL/WATER SEPARATOR SNOUT BMP 24R, OR APPROVED EQUAL. SECURE TO MANHOLE WITH FIVE (5) 5/8"x1-12" STAINLESS STEEL RED HEAD BOLTS, WASHERS AND NUTS, OR AS APPROVED BY MANUFACTURER.

DRAWN	AJD
DIV	STORM
REV	DATE



**CITY OF BEND**  
 STANDARD DRAWING  
 710 NW WALL ST., BEND, OREGON 97701

**STORMWATER SEDIMENTATION MANHOLE**

SCALE	NTS
DATE	11/01/2024
APPR	
STD DWG	STRM-7

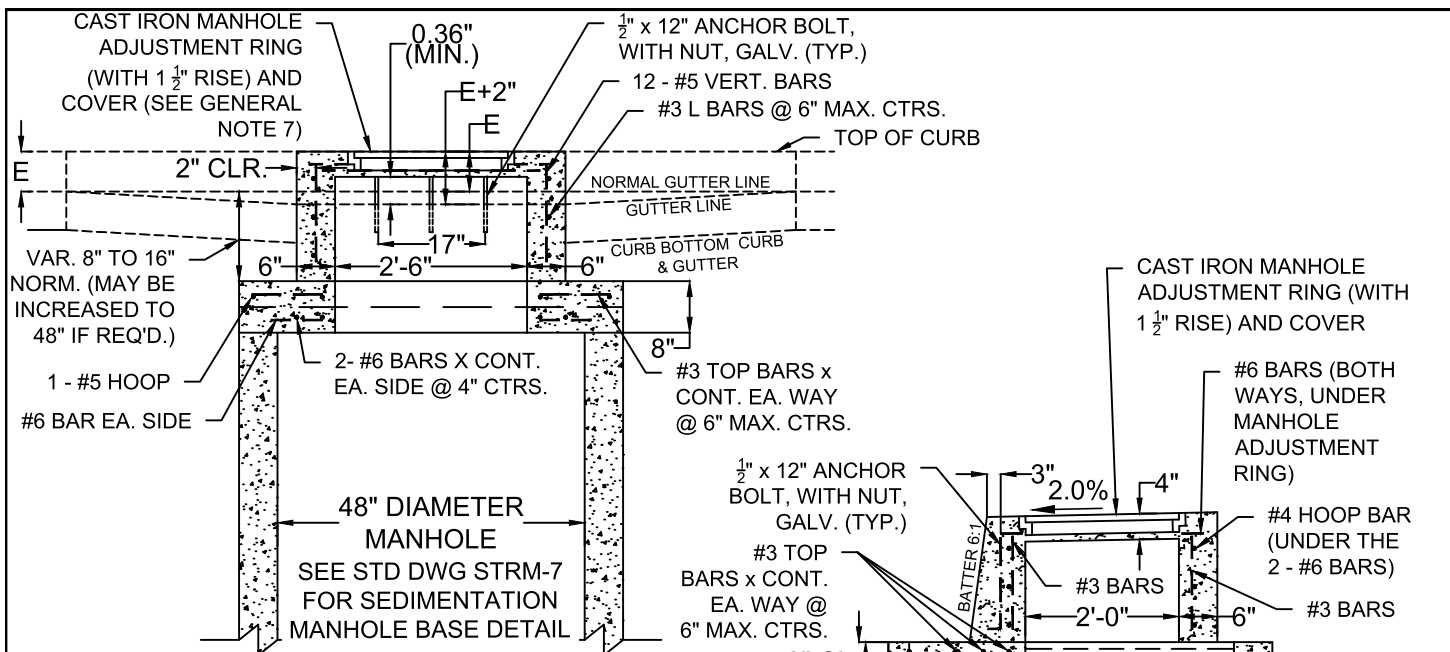

**SECTION B-B**

NTS

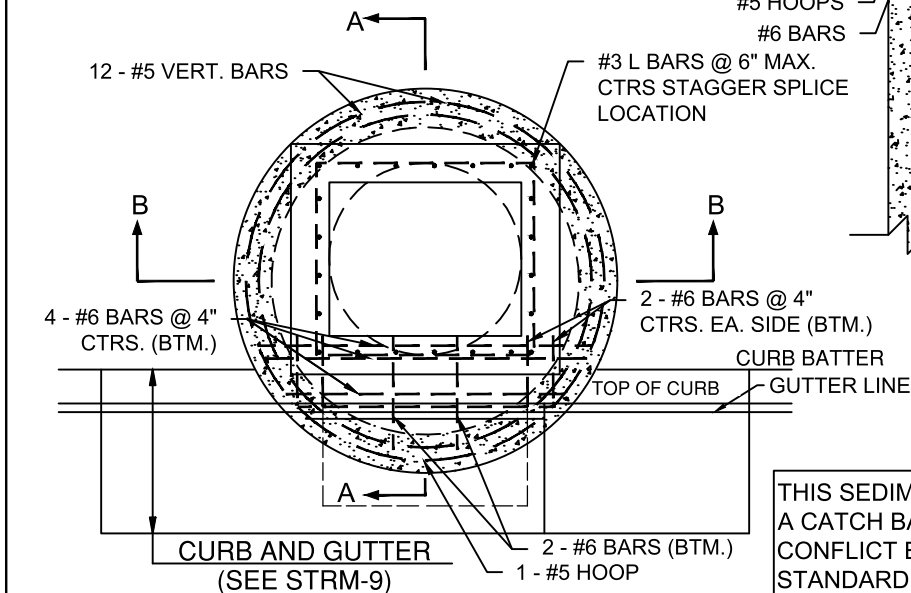

**SECTION A-A**

NTS

THIS SEDIMENTATION MANHOLE OPTION IS USED WHEN A CATCH BASIN OR INLET ARE PROPOSED AND A CONFLICT EXISTS PREVENTING INSTALLATION OF THE STANDARD SEDIMENTATION MANHOLE (STRM-7).

**NOTES:**

1. ALL REINFORCEMENT TO BE PLACED A MINIMUM OF 2" CLEAR OF NEAREST FACE OF CONCRETE UNLESS OTHERWISE SHOWN OR NOTED.
2. ALL PRECAST PRODUCTS SHALL CONFORM TO THE REQUIREMENTS OF ASTM C478.
3. ALL CONCRETE SHALL BE COMMERCIAL GRADE CONCRETE.
4. INLET TOP MAY BE CAST-IN-PLACE OR PRECAST. ALL PRECAST INLETS SHALL CONFORM TO REQUIREMENTS OF ASTM C913.
5. VARY ANCHOR BOLT LENGTH AND REINFORCING BAR PLACEMENT AS REQUIRED BY CURB EXPOSURE E.
6. SEE COB STD DWG R-3 FOR CURB DETAILS.
7. SEE ODOT STD DWG RD356 FOR MANHOLE ADJUSTMENT RING. SEE COB STD DWG STRM-8 FOR CAST IRON MANHOLE ADJUSTMENT RING AND COVER.
8. SUMP SIZE TO BE DESIGNED IN ACCORDANCE WITH COSM - 20 CF OF SUMP VOLUME FOR EACH 1.0 CFS DESIGN FLOW - NOT LESS THAN 48" DEPTH.

DRAWN A.JD DIV STORM REV DATE	 <b>CITY OF BEND</b>	<b>CITY OF BEND</b> STANDARD DRAWING 710 NW WALL ST., BEND, OREGON 97701	SCALE NTS DATE 11/01/2024 APPR STD DWG STRM-7A
<b>STORMWATER SEDIMENTATION MANHOLE - ALTERNATE</b>			

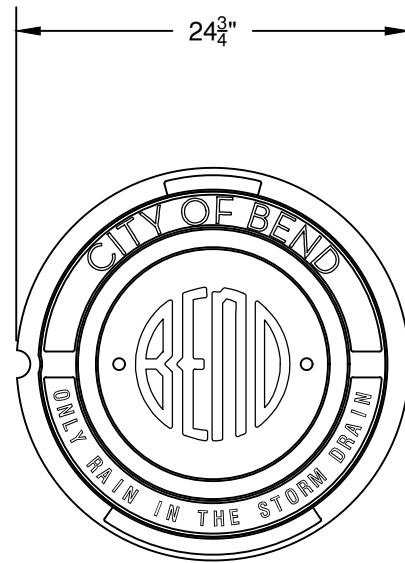
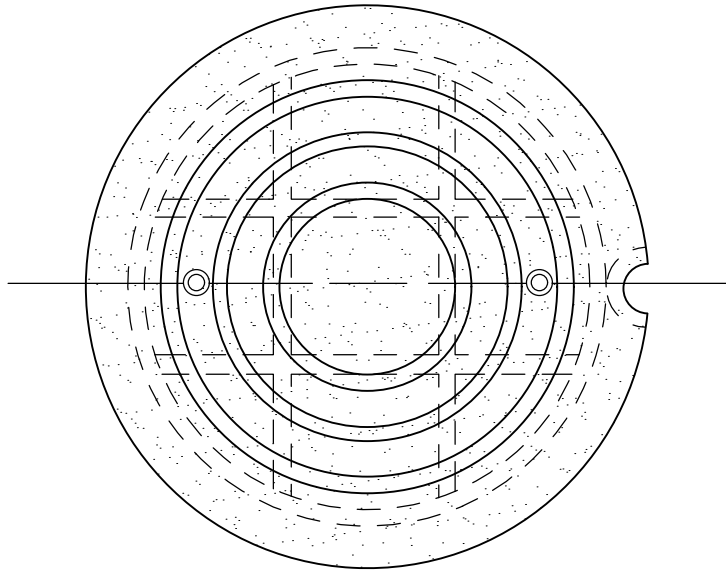

STORMWATER MANHOLE LID DETAIL

NTS

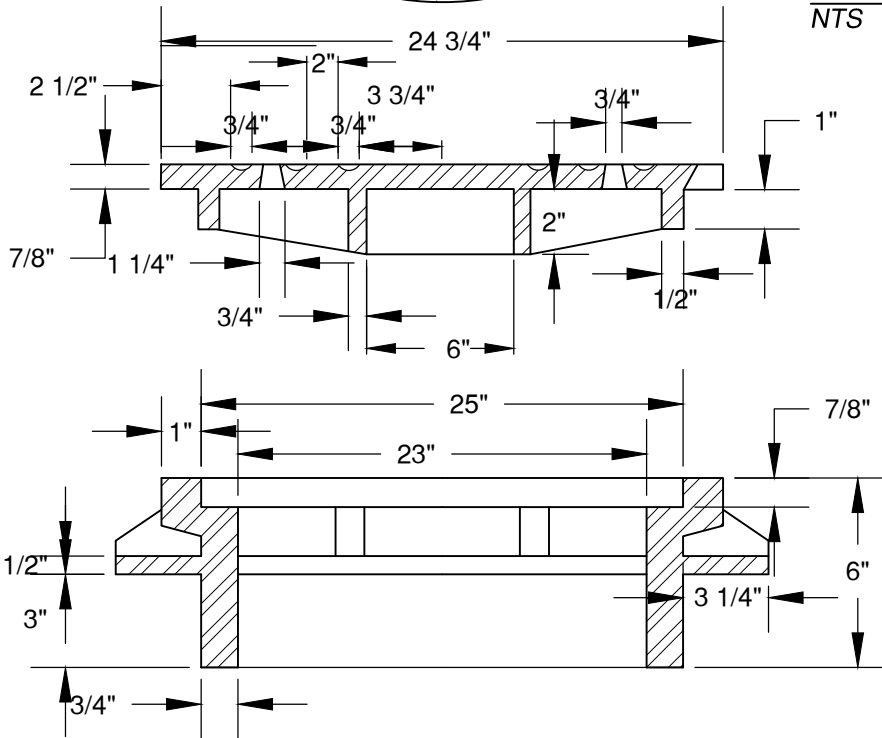

NOTE:

1. MANHOLE LID ONLY TO BE USED ON CITY OF BEND PUBLIC DRYWELLS AND SEDIMENTATION MANHOLES. PRIVATELY OWNED DRYWELLS AND SEDIMENT MANHOLES SHALL NOT USE A CITY OF BEND MANHOLE LID.
2. HINGED MANHOLE LIDS ARE NOT PERMITTED UNLESS OTHERWISE APPROVED BY THE CITY ENGINEER.
3. ALL MANHOLE LIDS SHALL BE PLACED OUTSIDE THE PATH OF TRAVEL OF SIDEWALKS AND DRIVEWAY APRONS.

DRAWN	AJD
DIV	STORM
REV	DATE



CITY OF BEND

CITY OF BEND

STANDARD DRAWING

710 NW WALL ST., BEND, OREGON 97701

STORMWATER MANHOLE LID DETAIL

SCALE NTS

DATE 01/31/2022

APPR

STD DWG STRM-8

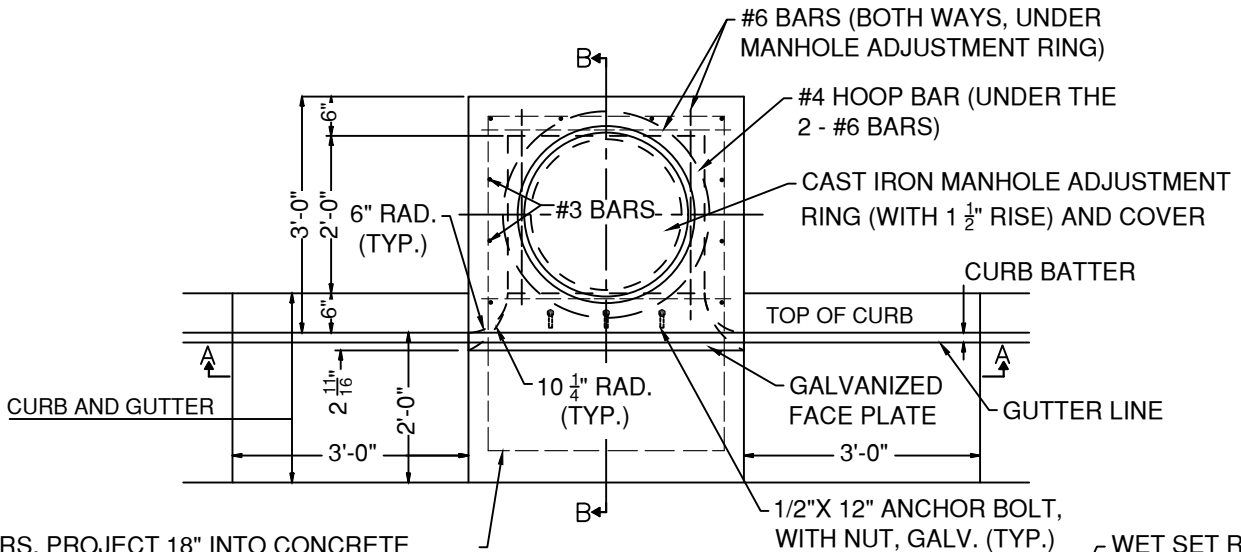

#3 BARS, PROJECT 18" INTO CONCRETE GUTTER PAN (BEND TO MATCH GUTTER PAN. SEE SECTION B-B)

**PLAN VIEW**

WET SET RISER INTO GROUT PER SECTION 00470.42 (SEE KEYWAY DETAIL BELOW)

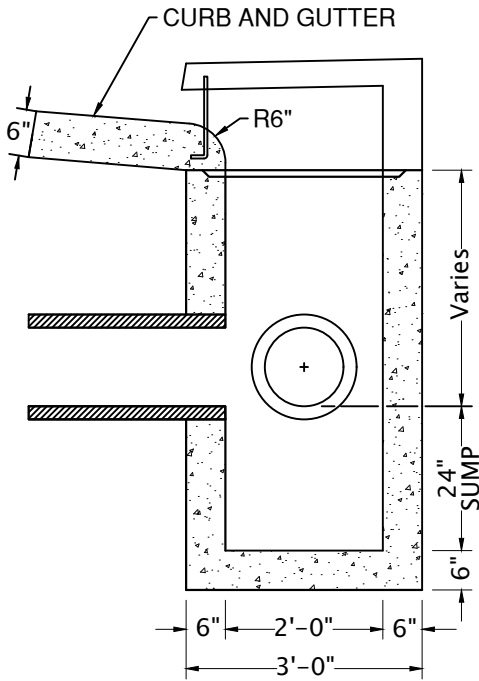

**SECTION B - B**

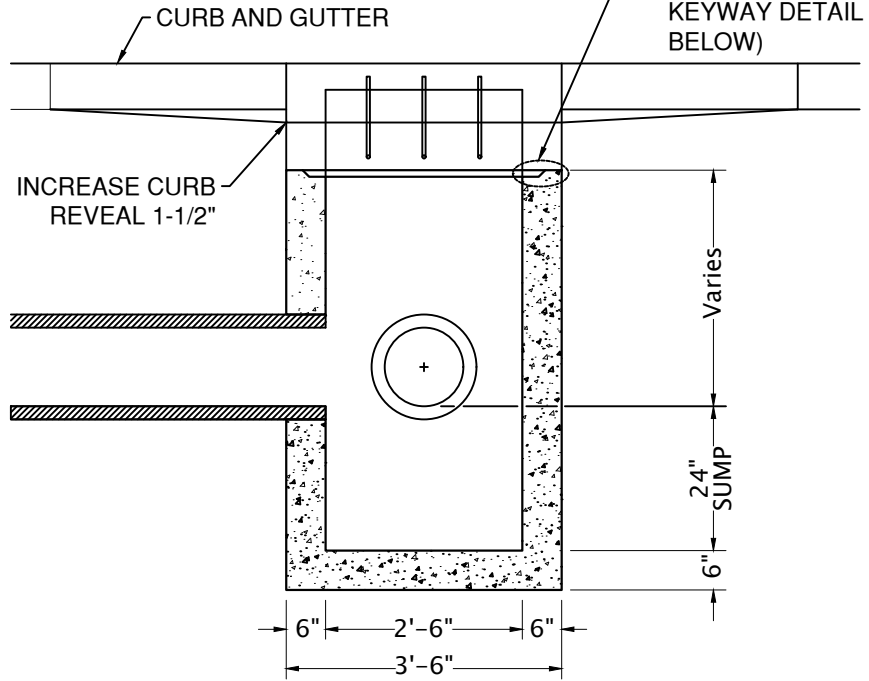

**SECTION A - A**

**NOTES:**

1. REMOVE SUFFICIENT CURB TO POUR BACK WALL. TOP SECTION MAY BE POURED MONOLITHIC WITH SIDEWALK.
2. CURB INLETS TO BE USED ON ARTERIAL AND COLLECTOR ROADWAYS.
3. "E" = CURB EXPOSURE.
4. SEE COB STD DWG STRM-8 FOR CAST IRON MANHOLE ADJUSTMENT RING AND COVER.
5. ALL PIPE CONNECTIONS TO BE GROUTED PER SPECIFICATION SECTION 00470.40.

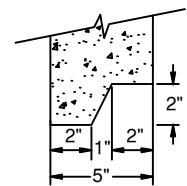

**KEYWAY DETAIL**

DRAWN	AJD
DIV	STORM
REV	DATE



**CITY OF BEND**

**CITY OF BEND**

STANDARD DRAWING

710 NW WALL ST., BEND, OREGON 97701

**STANDARD CURB INLET**

SCALE NTS

DATE 04/16/2026

APPR

STD DWG STRM-9

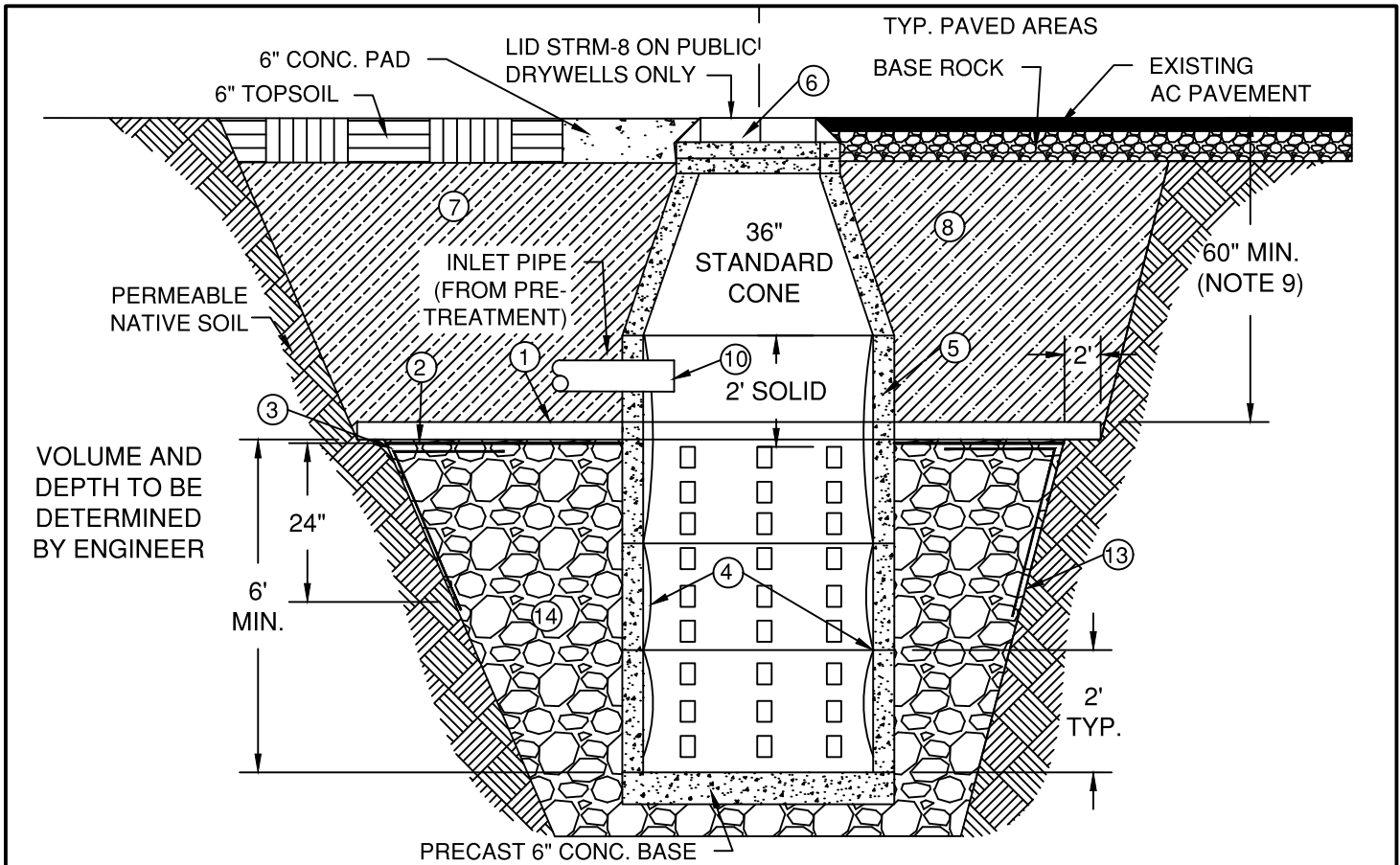

**NOTES:**

\* SEE ALSO THE CITY OF BEND STANDARDS AND SPECIFICATIONS FOR DESIGN CRITERIA

1. 6" CONCRETE CAP, SECTION 00440 COMMERCIAL GRADE CONCRETE, EXTEND TO UNDISTURBED MATERIAL 2' MIN. REQUIRED WITHIN ALL CITY OF BEND RIGHT OF WAY UNLESS NOTED OTHERWISE.
2. MOISTURE BARRIER-2 LAYERS OF 4 MIL POLY. ON ALL ROCK INSTALLATIONS.
3. NONWOVEN GEOFABRIC CONFORMING TO DRAINAGE GEOTEXTILE, OREGON TABLE 02320-1 REQUIRED ON ALL EARTH OR GRAVEL EXCAVATIONS TO 24" INTO ROCK. LAP 24" WITH MOISTURE BARRIER.
4. LINE INSIDE OF PERFORATED BARREL WITH HEAVY WEIGHT VINYL SCREEN, SUCH AS FULL FLOW VINYL SCREEN THAT MEETS THE REQUIREMENTS OF SPECIFICATION SECTION 00470. LINER SHALL BE FULLY AND CONTINUOUSLY ANCHORED, TOP AND BOTTOM OF EACH SECTION. ATTACH BY OVERLAPPING 12" MIN. BETWEEN JOINT OF MANHOLE CONE AND PERFORATED BARREL SECTION. INLET PIPE SHALL BE EXTENDED THROUGH THE SCREEN IF SCREEN IS ATTACHED ABOVE THE PIPE.
5. PRE-CAST SECTIONS SHALL CONFORM TO THE REQUIREMENTS OF ASTM C-478. ALL CONCRETE SHALL BE COMMERCIAL GRADE CONCRETE
6. STANDARD RING AND COVER REQUIRED IN RIGHT-OF-WAY AREAS. NO SLOTTED COVERS WILL BE ALLOWED IN LIEU OF A CATCH BASIN.
7. CLASS "A" BACKFILL COMPACTED TO 95.0% OPTIMUM DRY DENSITY (AASHTO T-99).
8. CLASS "B" BACKFILL COMPACTED TO 95.0% OPTIMUM DRY DENSITY (AASHTO T-99).
9. PERFORATIONS TO BE 60" BELOW EXISTING UNDISTURBED GROUND.
10. INLET PIPE MUST BE DESIGNED SO IT CAN BE PLUGGED IN CASE OF SPILL. ALL PIPE PENETRATIONS ARE TO BE GROUTED OR WATER-TIGHT SEALED. PIPE INLETS NOT TO ENTER DRYWELL WITH PERFORATED BARREL.
11. DRYWELL RIMS TO BE PLACED OUTSIDE OF SIDEWALK, APRON & STREET SURFACES UNLESS APPROVED BY THE CITY ENGINEER.
12. PLANS SHALL PROVIDE VOLUME AND AREA OF ROCK PLACEMENT. ROCK PLACEMENT SHALL BE OUTSIDE WATER/SEWER TRENCHES. WHERE ROCK ENTERS PRIVATE PROPERTY, A DRAINAGE EASEMENT SHALL BE RECORDED.
13. GEOFABRIC TO BE EXTENDED FROM THE CONCRETE CAP TO BOTTOM OF DRYWELL STRUCTURE. WHERE THE EXCAVATION IS WITHIN SOLID ROCK (NO SIDEWALL SLOUGHING), GEOFABRIC CAN BE WAIVED AT ENGINEER'S DISCRETION
14. CLEAN 2"-3" CRUSHED OR RIVER RUN DRAIN ROCK PER SECTION 00470.18.

DRAWN AJD	
DIV STORM	
REV	DATE



CITY OF BEND

**CITY OF BEND**

STANDARD DRAWING

710 NW WALL ST., BEND, OREGON 97701

**STANDARD PRE-CAST DRYWELL**

SCALE NTS

DATE 03/22/2023

APPR

STD DWG STRM-10

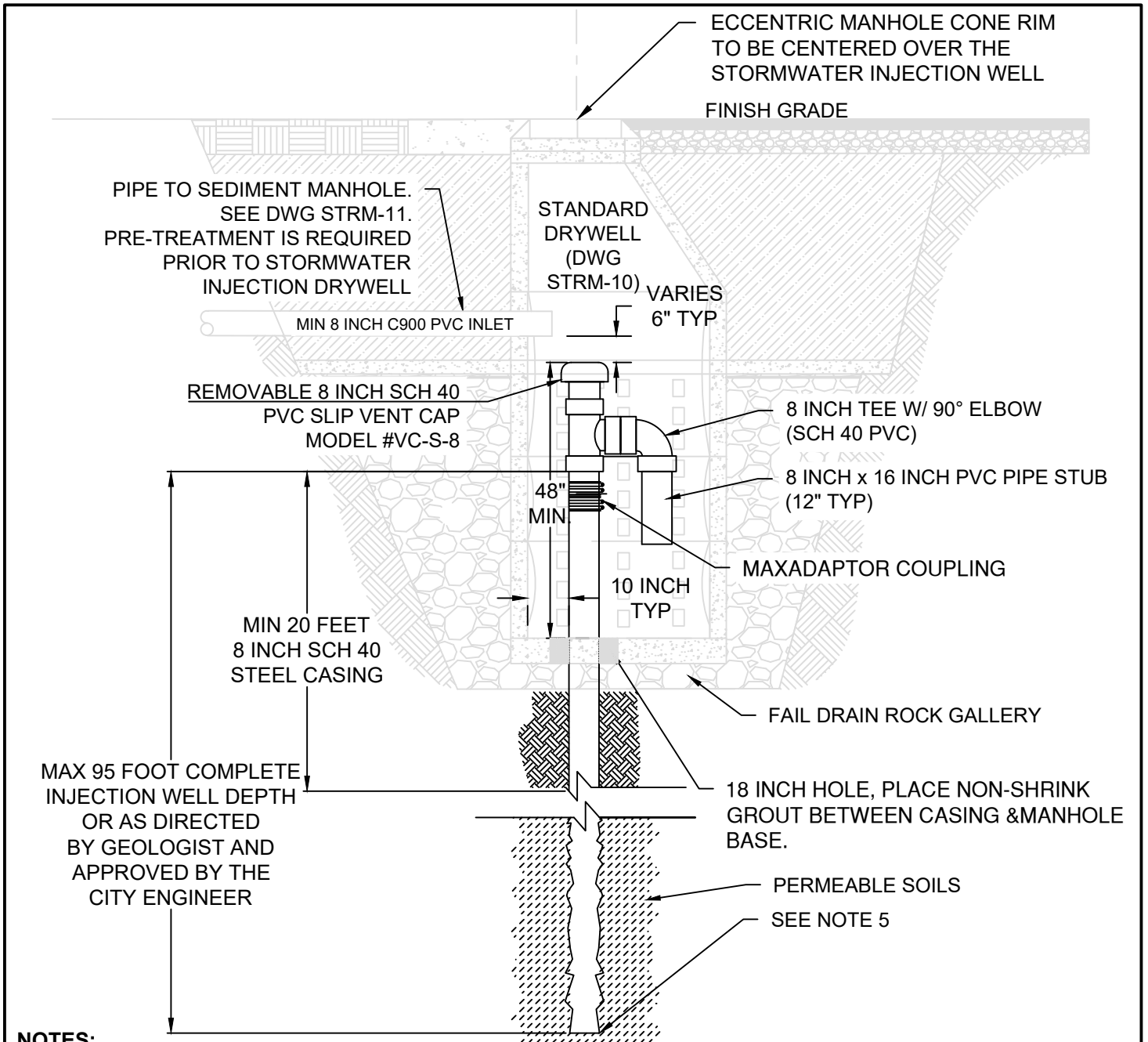

**NOTES:**

1. MODIFIED DRYWELLS SHALL ONLY BE INSTALLED IN LOCATIONS WHERE THE GEOTECHNICAL REPORT AND FIELD EXPLORATION DEMONSTRATE THAT EXISTING DRYWELL HAS FAILED DUE TO POOR-DRAINING SOIL CONDITIONS.
2. STORMWATER INJECTION WELLS ARE ONLY ALLOWED ON ALLEYS, LOCAL ROADS, AND COLLECTOR ROADS WITHIN RESIDENTIAL LAND USE ZONES.
3. STORMWATER INJECTION WELLS ARE PROHIBITED IN 1 AND 2 YEAR DRINKING WATER PROTECTION TIME OF TRAVEL AREAS AND WITHIN 100 FEET OF PRIVATE WATER WELLS.
4. STORMWATER INJECTION WELLS ARE PROHIBITED IN THE OLD MILL AND NORTH BEND'S PERCHED GROUNDWATER AREAS.
5. STORMWATER INJECTION WELLS MUST MAINTAIN A MINIMUM VERTICAL SEPARATION OF 53 FEET FROM THE BOTTOM OF THE INJECTION WELL AND REGIONAL GROUNDWATER AQUIFER. REFER TO THE DIGITAL MAPS FOR GROUNDWATER DEPTH.

DRAWN CJH		 <b>CITY OF BEND</b>	<b>CITY OF BEND</b> STANDARD DRAWING 710 NW WALL ST., BEND, OREGON 97701	SCALE NTS
DIV STORM				DATE 04/16/2026
REV	DATE			APPR
			<b>MODIFIED DRYWELL W/ STORM INJECTION WELL</b>	STD DWG STRM-10A

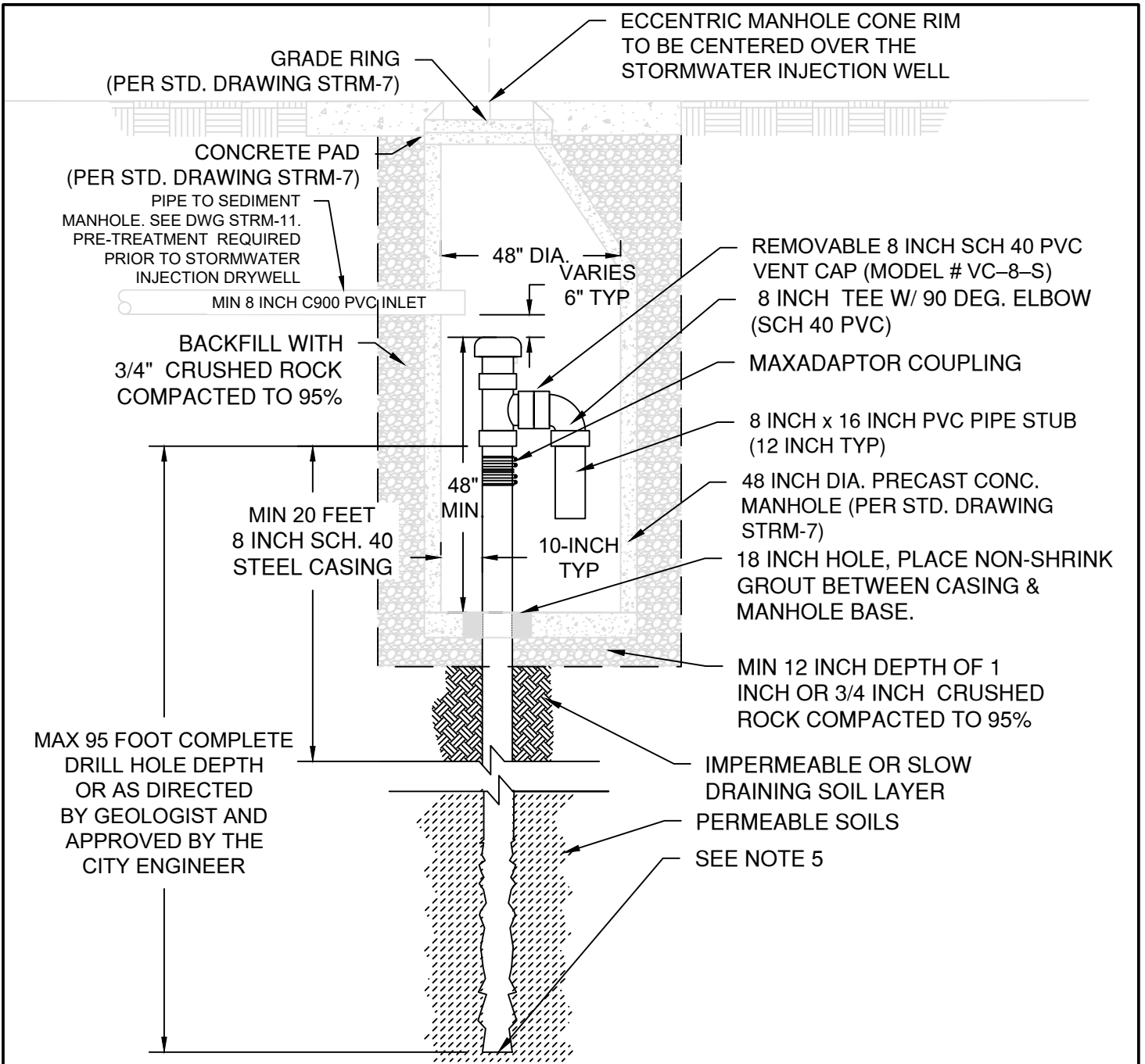

**NOTES:**

1. STORMWATER INJECTION WELLS SHALL ONLY BE INSTALLED IN LOCATIONS WHERE THE GEOTECHNICAL REPORT AND FIELD EXPLORATION DEMONSTRATE THAT STANDARD DRYWELLS ARE NOT FEASIBLE DUE TO POOR-DRAINING SOIL CONDITIONS.
2. STORMWATER INJECTION WELLS ARE ONLY ALLOWED ON LOCAL ALLEYWAYS, OR COLLECTOR ROADS WITHIN RESIDENTIAL LAND USE ZONES.
3. STORMWATER INJECTION WELLS ARE PROHIBITED IN 1 AND 2 YEAR DRINKING WATER PROTECTION TIME OF TRAVEL AREAS AND WITHIN 100 FEET OF PRIVATE WATER WELLS.
4. STORMWATER INJECTION WELLS ARE PROHIBITED IN THE OLD MILL AND NORTH BEND'S PERCHED GROUNDWATER AREAS.
5. STORMWATER INJECTION WELLS MUST MAINTAIN A MINIMUM VERTICAL SEPARATION OF 53 FEET FROM THE BOTTOM OF THE STORMWATER INJECTION WELL AND REGIONAL GROUNDWATER AQUIFER. REFER TO THE DIGITAL MAPS FOR GROUNDWATER DEPTH.

DRAWN CJH DIV STORM REV DATE	 <b>CITY OF BEND</b>	<b>CITY OF BEND</b> STANDARD DRAWING 710 NW WALL ST., BEND, OREGON 97701	SCALE NTS DATE 04/16/2026 APPR STD DWG STRM-10B
<b>STORMWATER INJECTION WELL</b>			

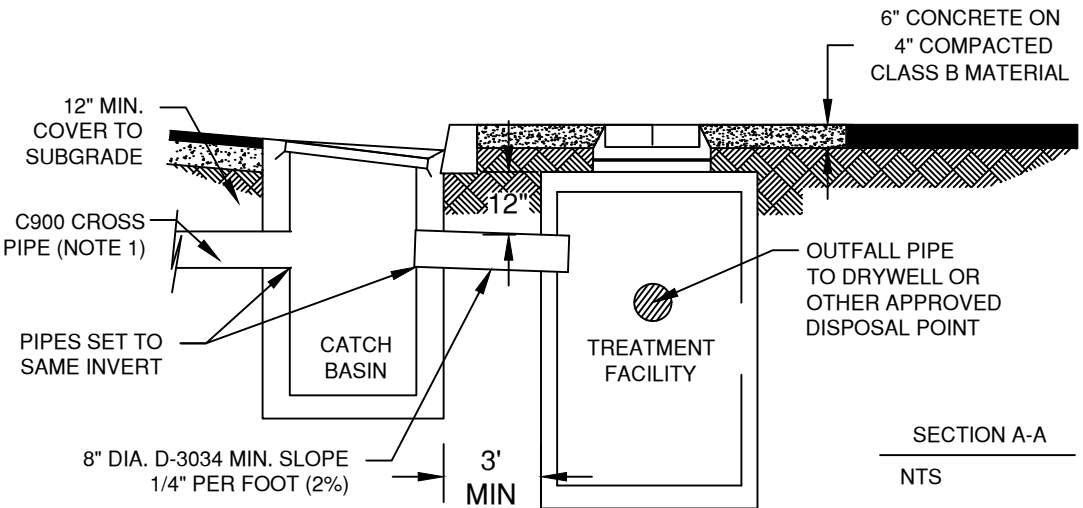
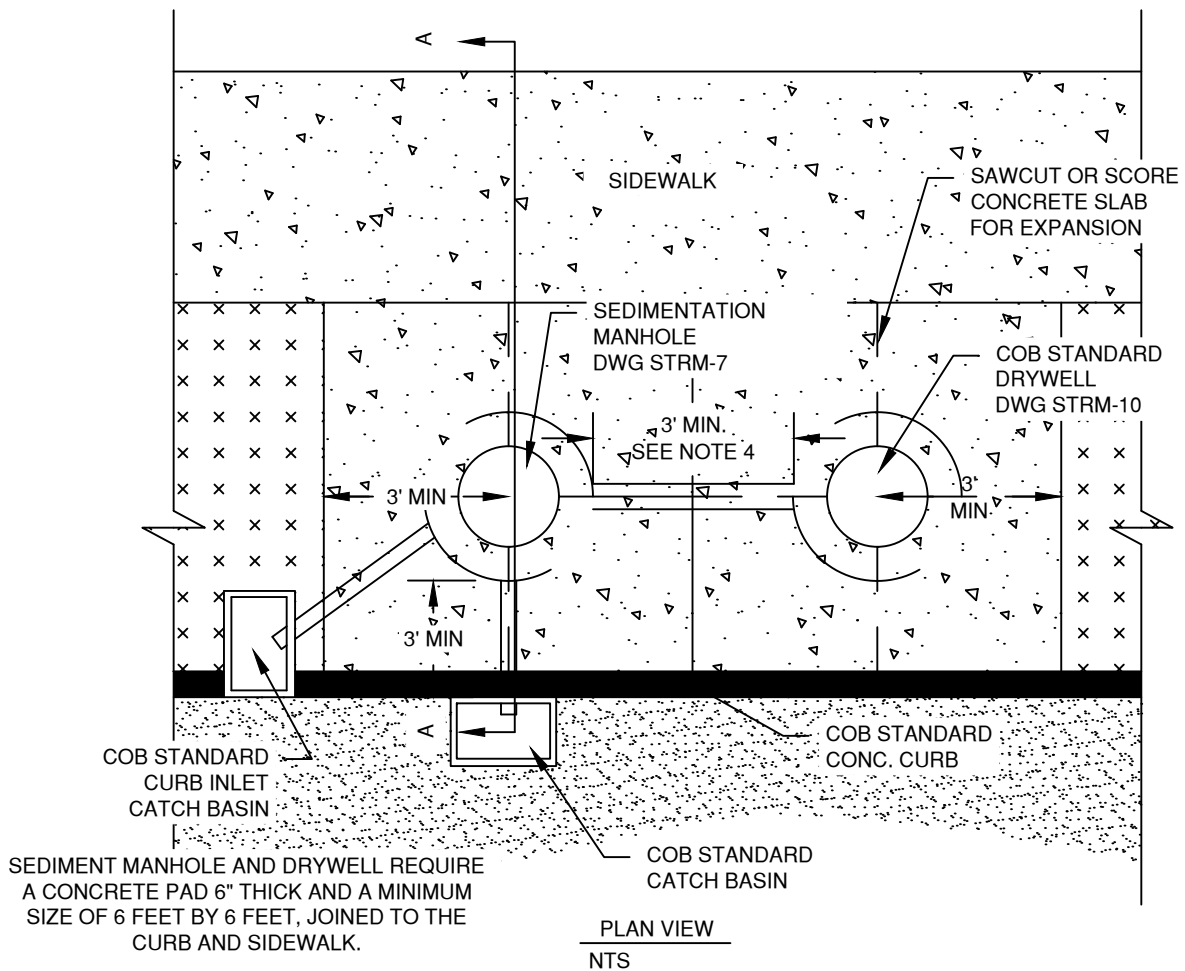

- NOTES:**
1. CROSS PIPE ELEV MAY REQUIRE OTHER UTILITIES (SEWER, WATER, ETC) TO BE LOWERED TO PROVIDE MINIMUM SEPARATIONS
  2. ALL PIPE PENETRATIONS ARE TO BE GROUTED OR WATER TIGHT SEALED.
  3. DRYWELL AND TREATMENT FACILITY NOT TO BE PLACED IN DRIVEWAY OR SIDEWALK UNLESS APPROVED BY THE CITY ENGINEER.
  4. WHEN DRY UTILITIES OR WATER/SEWER SERVICES ARE TO BE INSTALLED BETWEEN THE SEDIMENTATION MANHOLE AND DRYWELL, UTILITIES MUST MAINTAIN A MIN 3' HORIZONTAL SEPARATION FROM THE OUTSIDE EDGE OF STRUCTURES. STRUCTURES TO BE SEPARATED BY A MIN 5'. UTILITIES MUST NOT BE INSTALLED ABOVE THE DRYWELL DRAINROCK GALLEY SLAB.

DRAWN AJD	
DIV STORM	
REV	DATE



**CITY OF BEND**  
STANDARD DRAWING  
710 NW WALL ST., BEND, OREGON 97701

**DRYWALL W/ MANUFACTURED TREATMENT LAYOUT**

SCALE NTS
DATE 04/16/2026
APPR
STD DWG STRM-11

DETAIL SHOWING  
GRATE ORIENTATION  
TO CURB LINE. SEE  
STD DWG STRM-13A  
FOR GRATE DETAIL

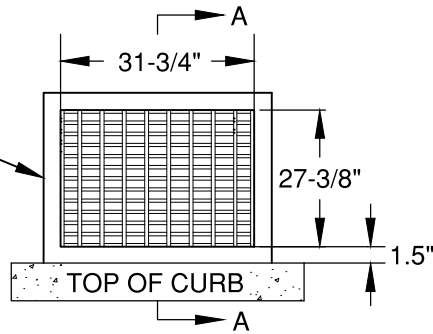

**PLAN VIEW**

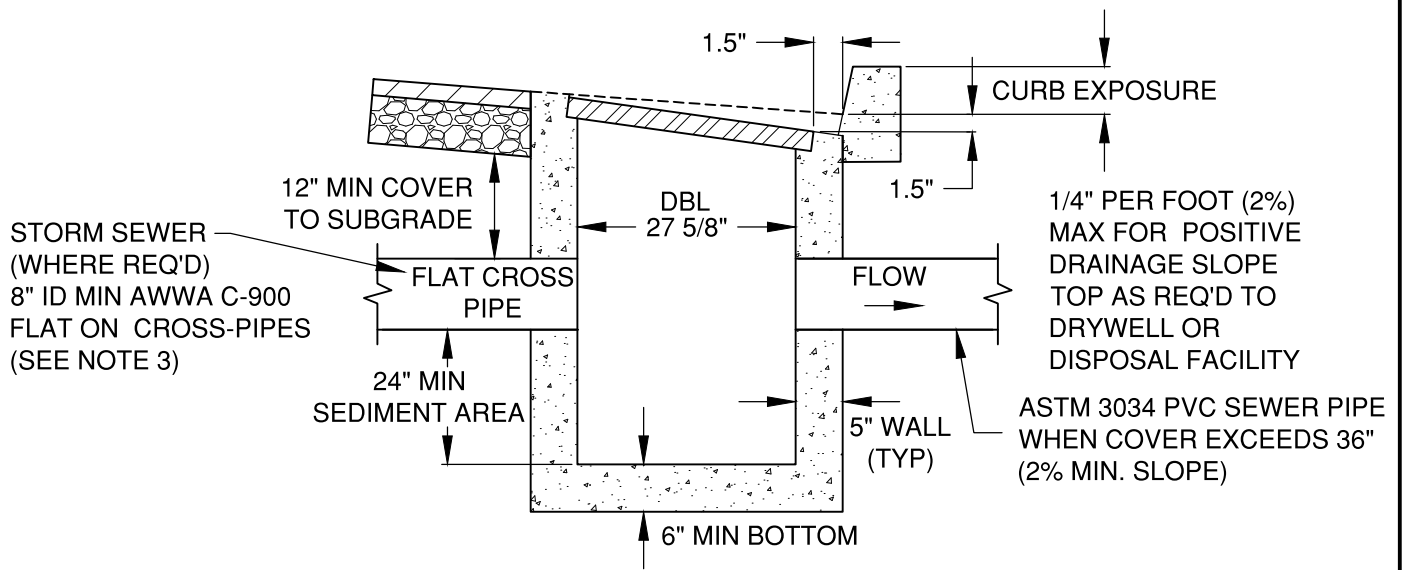

**SECTION A-A**

**NOTES:**

1. UNLESS OTHERWISE SPECIFIED, ALL CATCH BASINS TO BE DOUBLE CATCH BASIN
2. BACKFILL TO BE COMPACTED TO 95% OF OPTIMUM PER SPECIFICATION SECTION 00330.43
3. CROSS PIPE ELEV MAY REQUIRE OTHER UTILITIES (SEWER, WATER, ETC) TO BE LOWERED TO PROVIDE MINIMUM SEPARATIONS
4. ALL PIPE CONNECTIONS TO BE GROUTED PER SPECIFICATION SECTION 00470.40
5. CONTRACTOR IS RESPONSIBLE TO KEEP CATCH BASIN CLEAN AND FREE OF SEDIMENT DURING CONSTRUCTION
6. CONTRACTOR IS RESPONSIBLE TO COVER AND BARRICADE ALL CATCH BASINS UNTIL GRATE IS INSTALLED
7. STANDARD CATCH BASINS ARE LIMITED TO LOCAL STREETS AND SHALL NOT BE USED ON ARTERIAL & COLLECTOR ROADWAYS. CURB INLETS ARE TO BE USED ON ARTERIAL & COLLECTOR ROADWAYS.
8. SEE DRG R-11 FOR PAVEMENT RESURFACING

DRAWN AJD		<b>CITY OF BEND</b> STANDARD DRAWING 710 NW WALL ST., BEND, OREGON 97701	SCALE NTS
DIV STORM			DATE 03/22/2023
REV	DATE		APPR
		<b>STANDARD CATCH BASIN</b>	STD DWG STRM-12

DETAIL SHOWING  
GRATE ORIENTATION  
TO CURB LINE. SEE  
STD DWG STRM-13A  
FOR GRATE DETAIL

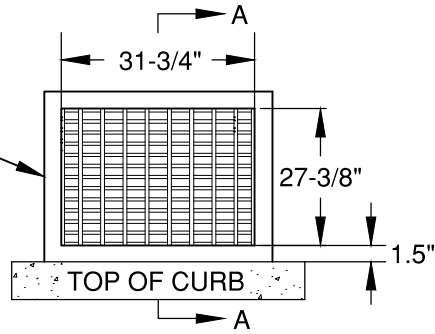

**PLAN VIEW**

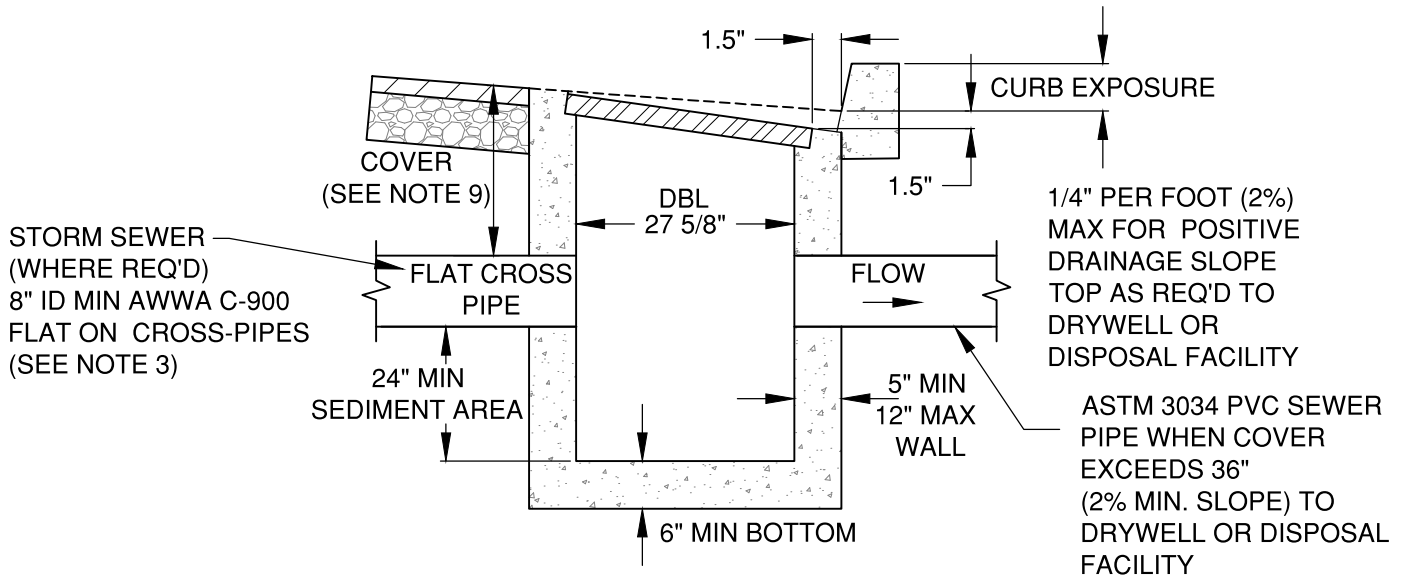

**SECTION A-A**

**NOTES:**

1. UNLESS OTHERWISE SPECIFIED, ALL CATCH BASINS TO BE DOUBLE CATCH BASIN
2. BACKFILL TO BE COMPACTED TO 95% OF OPTIMUM PER SPECIFICATION SECTION 00330.43
3. CROSS PIPE ELEVATE MAY REQUIRE OTHER UTILITIES (SEWER, WATER, ETC) TO BE LOWERED TO PROVIDE MINIMUM SEPARATIONS.
4. ALL PIPE CONNECTIONS TO BE GROUTED PER SPECIFICATION SECTION 00470.40. GROUT SHOULD BE LEVELED TO ALIGN FLUSH WITH THE INTERIOR WALL WITH NO EXTENSION OF GROUT ONTO THE INTERNAL SURFACE AREA OF THE CATCH BASIN.
5. CONTRACTOR IS RESPONSIBLE TO KEEP CATCH BASIN CLEAN AND FREE OF SEDIMENT DURING CONSTRUCTION
6. CONTRACTOR IS RESPONSIBLE TO COVER AND BARRICADE ALL CATCH BASINS UNTIL GRATE IS INSTALLED
7. STANDARD CATCH BASINS ARE LIMITED TO LOCAL STREETS AND SHALL NOT BE USED ON ARTERIAL & COLLECTOR ROADWAYS. CURB INLETS ARE TO BE USED ON ARTERIAL & COLLECTOR ROADWAYS.
8. SEE DRG R-11 FOR PAVEMENT RESURFACING
9. ON LOCAL ROADS, PIPE COVER IS TO BE 22-INCH FROM FINISHED GRADE TO TOP OF PIPE. ON COLLECTORS AND ARTERIAL STREET SECTIONS (STD DWG R-1), MAINTAIN MIN COVER OF 24-INCHES FROM GUTTER FINISHED GRADE.

DRAWN AJD		<b>CITY OF BEND</b> STANDARD DRAWING 710 NW WALL ST., BEND, OREGON 97701	SCALE NTS
DIV STORM			DATE 11/01/2024
REV	DATE		APPR
		<b>STANDARD CATCH BASIN</b>	STD DWG STRM-12A

DETAIL SHOWING  
GRATE ORIENTATION  
TO CURB LINE. SEE  
STD DWG STRM-13A  
FOR GRATE DETAIL

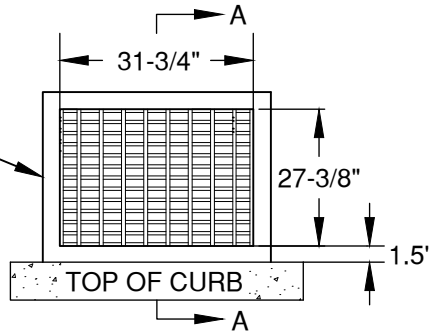

**PLAN VIEW**

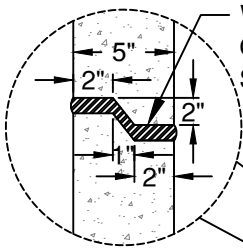

WET SET RISER INTO  
GROUT PER SPEC  
SECTION 00470.42

**KEYWAY DETAIL**

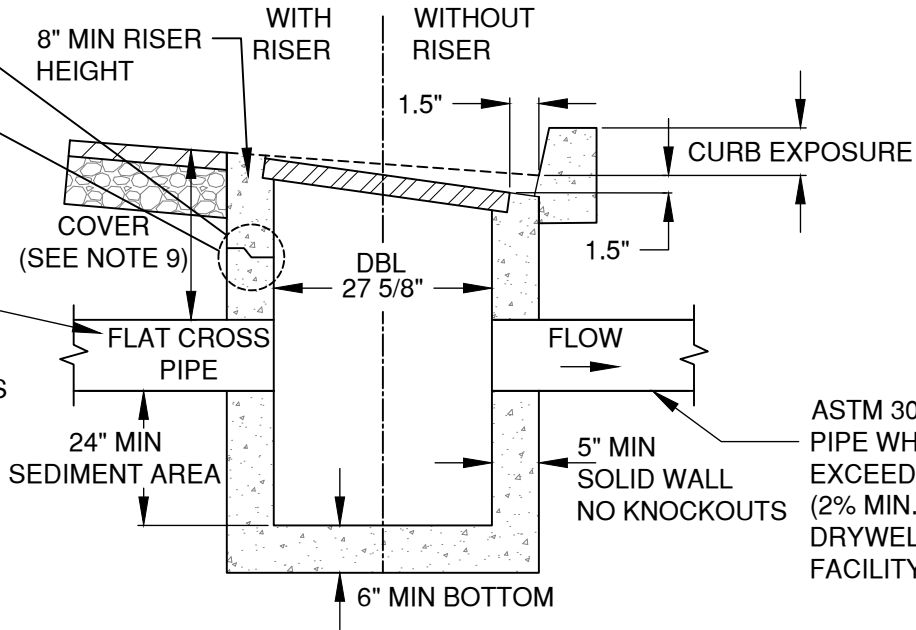

**SECTION A-A**

STORM SEWER  
(WHERE REQ'D)  
8" ID MIN AWWA C-900  
FLAT ON CROSS-PIPES  
(SEE NOTE 3)

ASTM 3034 PVC SEWER  
PIPE WHEN COVER  
EXCEEDS 36"  
(2% MIN. SLOPE) TO  
DRYWELL OR DISPOSAL  
FACILITY.

**NOTES:**

1. UNLESS OTHERWISE SPECIFIED, ALL CATCH BASINS TO BE DOUBLE CATCH BASIN
2. BACKFILL TO BE COMPACTED TO 95% OF OPTIMUM PER SPECIFICATION SECTION 00330.43
3. CROSS PIPE ELEVATE MAY REQUIRE OTHER UTILITIES (SEWER, WATER, ETC) TO BE LOWERED TO PROVIDE MINIMUM SEPARATIONS.
4. CONTRACTOR IS RESPONSIBLE TO KEEP CATCH BASIN CLEAN AND FREE OF SEDIMENT DURING CONSTRUCTION
5. CONTRACTOR IS RESPONSIBLE TO COVER AND BARRICADE ALL CATCH BASINS UNTIL GRATE IS INSTALLED
6. STANDARD CATCH BASINS ARE LIMITED TO LOCAL STREETS AND SHALL NOT BE USED ON ARTERIAL & COLLECTOR ROADWAYS. CURB INLETS ARE TO BE USED ON ARTERIAL & COLLECTOR ROADWAYS.
7. SEE DWG R-11 FOR PAVEMENT RESURFACING.
8. PRE-CAST BASINS SHALL NOT CONTAIN KNOCKOUTS. SAW-CUT OR CORE DRILL ALL PIPE PENETRATIONS AND GROUT PER SPECIFICATION SECTION 00470.40. GROUT SHOULD BE LEVELLED TO ALIGN FLUSH WITH THE INTERIOR WALL WITH NO EXTENSION OF GROUT ONTO THE INTERNAL SURFACE AREA OF THE CATCH BASIN.
9. ON LOCAL ROADS, PIPE COVER IS TO BE 22-INCH FROM FINISHED GRADE TO TOP OF PIPE. ON COLLECTORS AND ARTERIAL STREET SECTIONS (STD DWG R-1), MAINTAIN MIN COVER OF 24-INCHES FROM GUTTER FINISHED GRADE.

DRAWN CJH	
DIV STORM	
REV	DATE



**CITY OF BEND**  
STANDARD DRAWING  
710 NW WALL ST., BEND, OREGON 97701

**STANDARD CATCH BASIN (PRE-CAST)**

SCALE NTS
DATE 04/16/2026
APPR
STD DWG STRM-12B

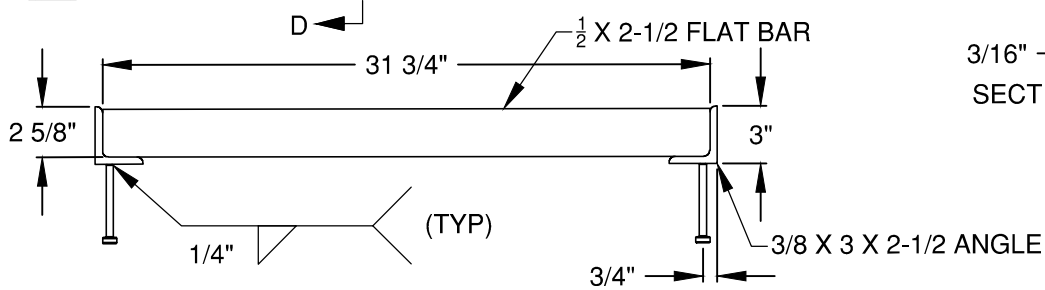
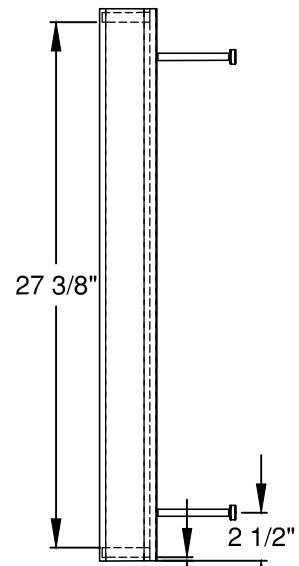
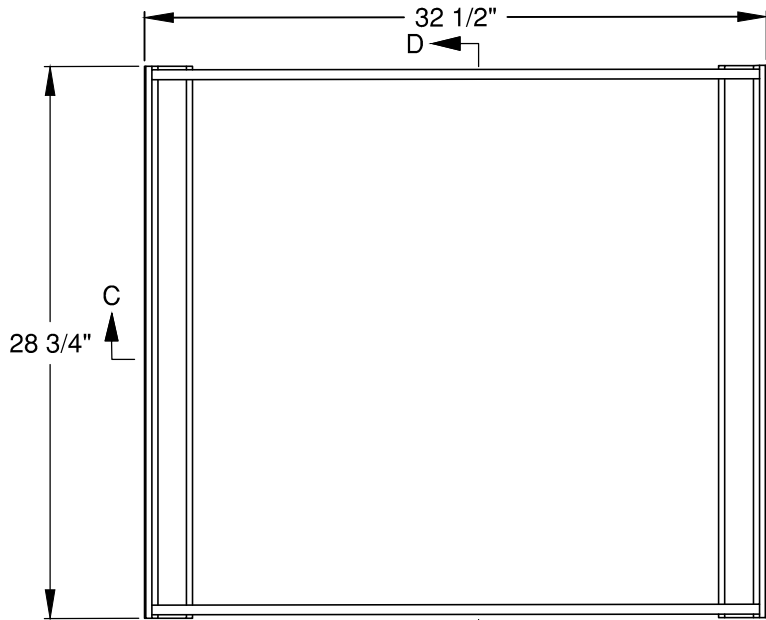

SECTION C-C

**STEEL FRAME**

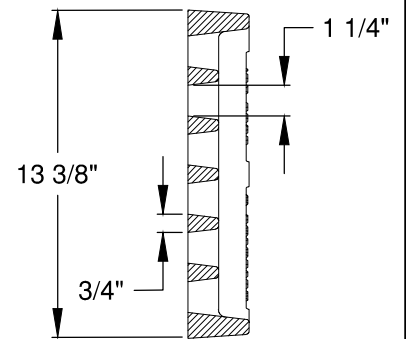
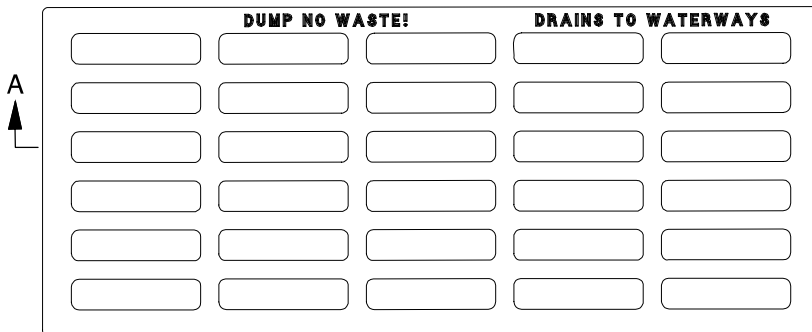

SECTION B-B

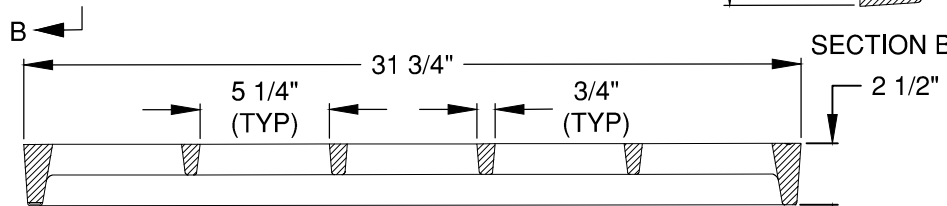

SECTION A-A

**DUCTILE IRON GRATE**

DRAWN AJD  
 DIV STORM  
 REV DATE



CITY OF BEND

CITY OF BEND

STANDARD DRAWING

710 NW WALL ST., BEND, OREGON 97701

STORMWATER GRATE

SCALE NTS

DATE 01/31/2022

APPR

STD DWG STRM-13A

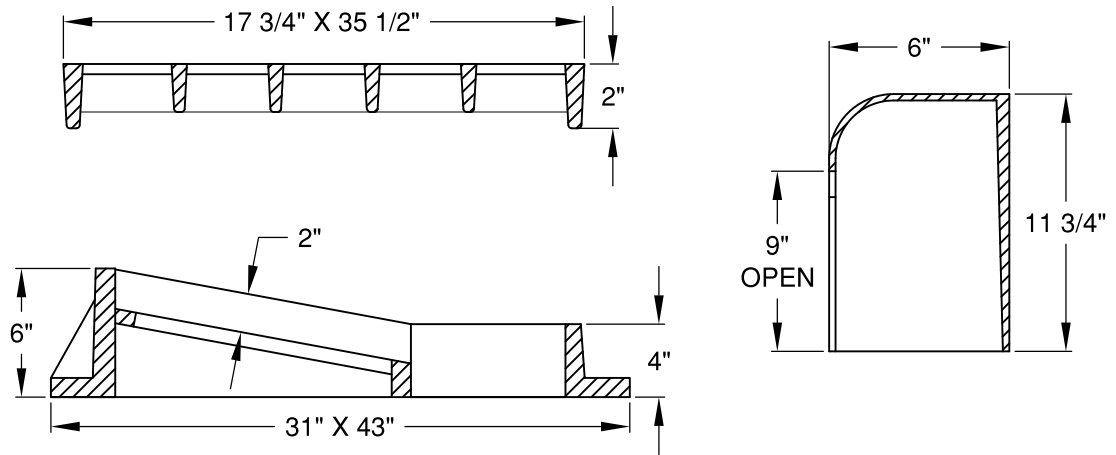

**CAST IRON COMBINATION CATCH BASIN INLET**

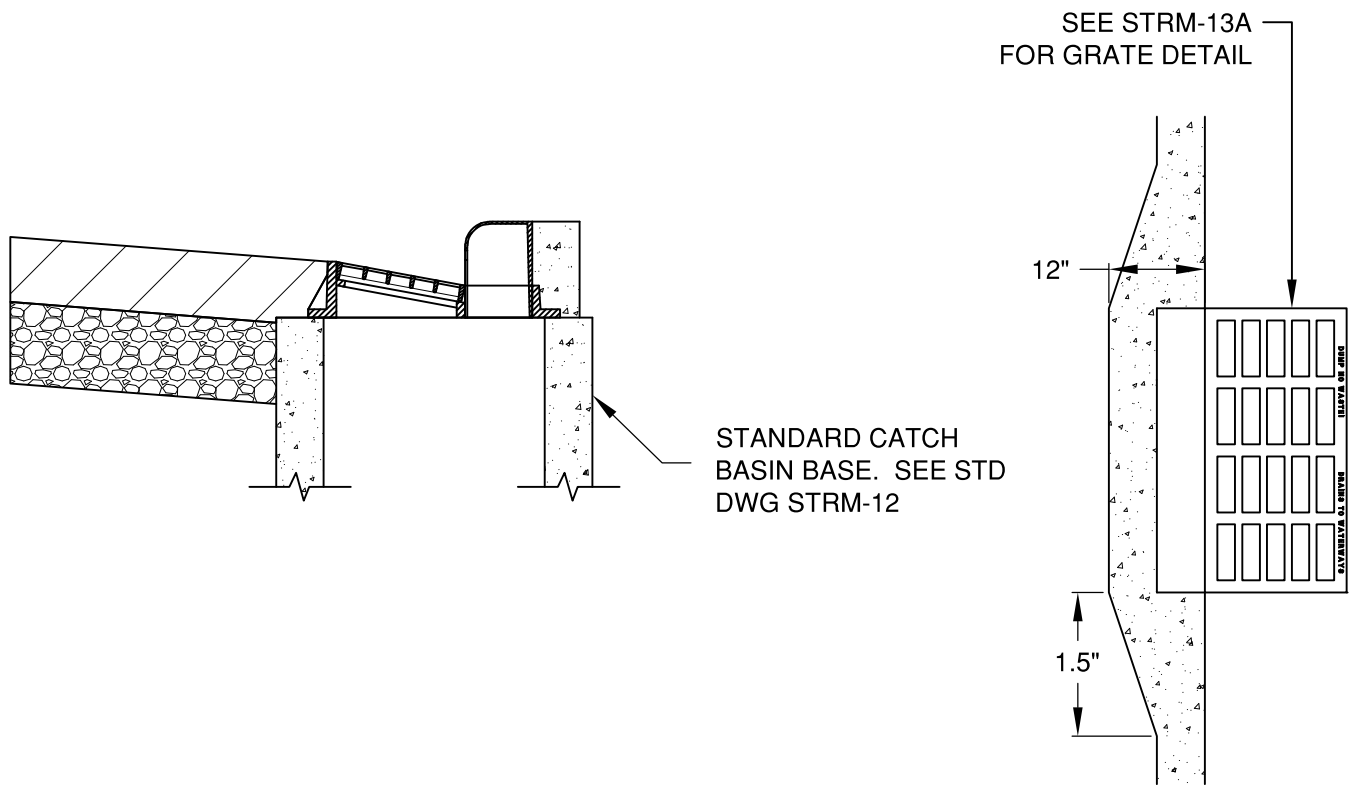

**NOTES:**

1. SEE NOTES ON STD DWG STRM-12
2. COMBINATION CATCH BASIN INLET TO BE USED ON COLLECTOR AND LOCAL STREETS WHEN THE ROAD GRADE EXCEED 6%

DRAWN AJD	
DIV STORM	
REV	DATE



CITY OF BEND

**CITY OF BEND**

STANDARD DRAWING

710 NW WALL ST., BEND, OREGON 97701

**COMBINATION CATCH BASIN INLET**

SCALE NTS

DATE 11/01/2024

APPR

STD DWG STRM-13B

NOTE: TAPER LENGTHS SHALL BE UTILIZED FOR ASPHALT PAVEMENT OVERLAY PROJECTS. ADJUST GRIND AS REQUIRED.

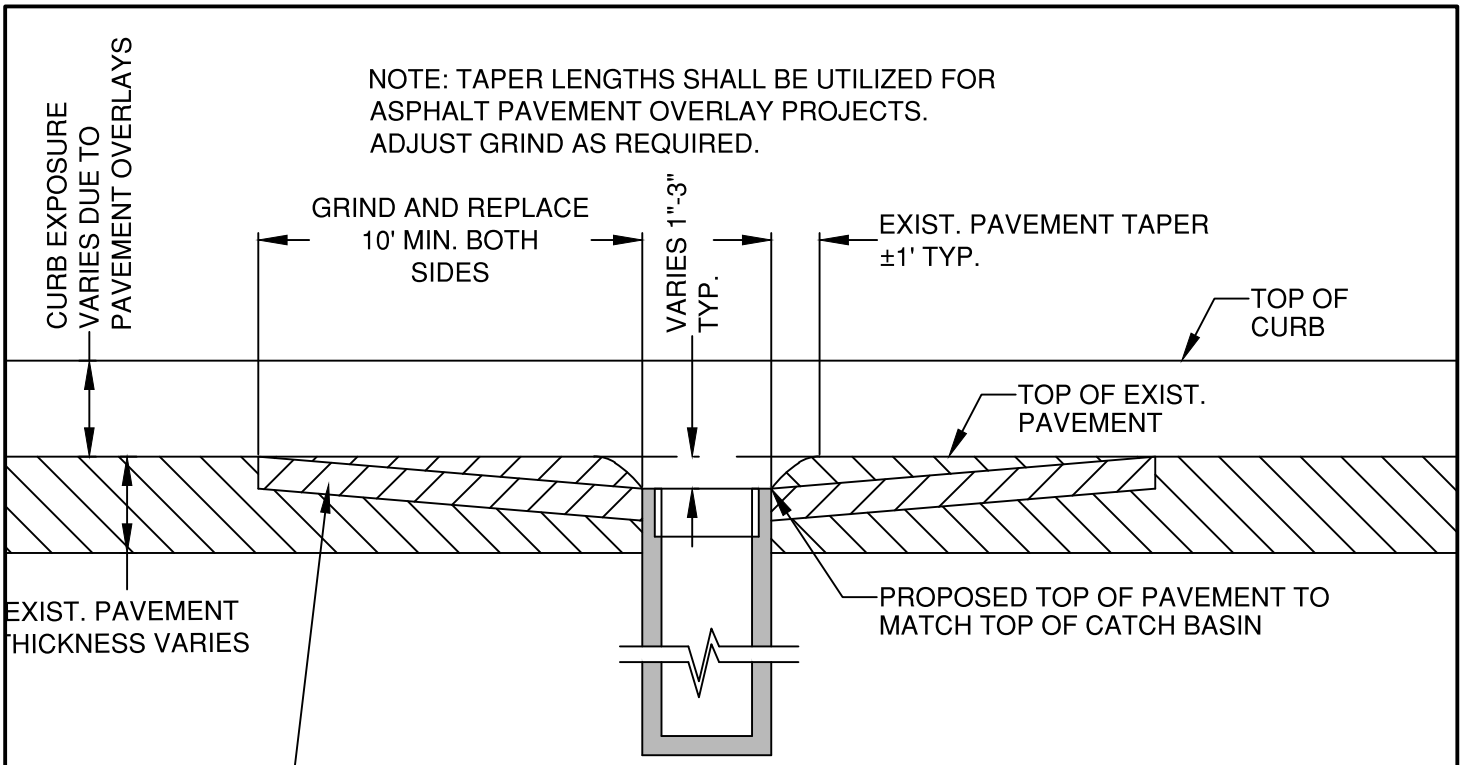

GRIND AND REPLACE EXIST. AC PAVEMENT. (2" DEPTH) APPLY BITUMINOUS TACK COAT ON ALL SURFACES

**SECTION VIEW**

SCALE:  
HORIZONTAL: 1"=5'  
VERTICAL: 1"=1'

EXIST. TOP OF PAVEMENT TAPER ±1' HORIZONTAL AROUND CATCH BASIN AND 1"-3" VERTICAL

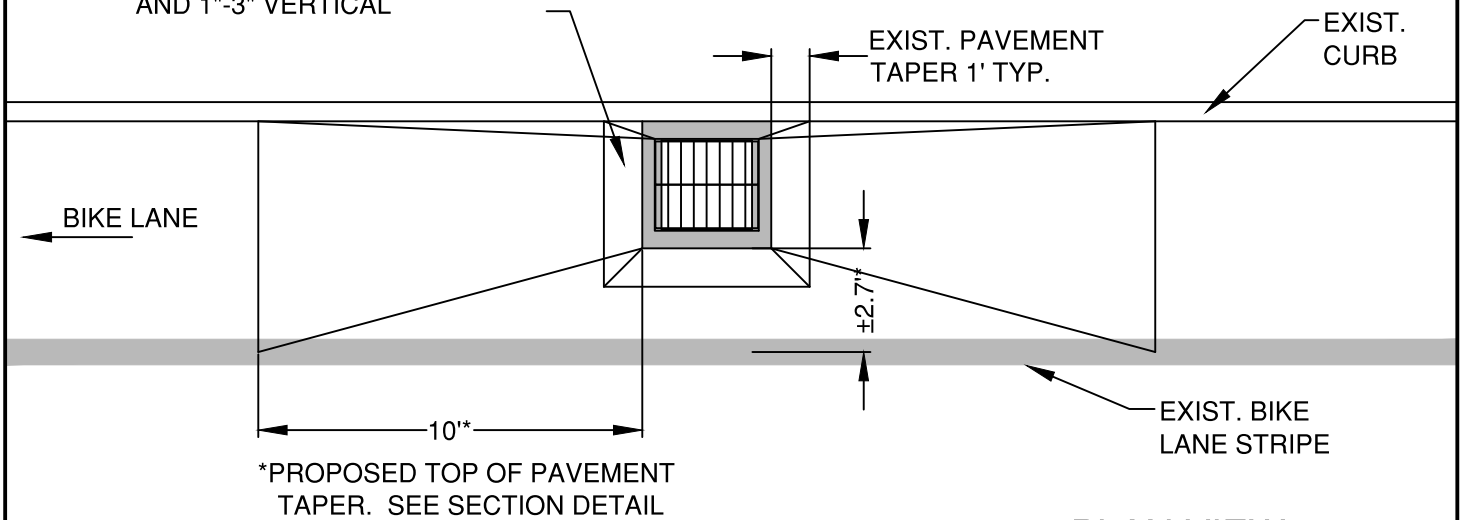

**PLAN VIEW**

SCALE:  
HORIZONTAL: 1"=5'

DRAWN LJC	
DIV STORM	
REV	DATE



CITY OF BEND

**CITY OF BEND**

STANDARD DRAWING

710 NW WALL ST., BEND, OREGON 97701

**EXISTING CATCH BASIN PAVEMENT RESURFACING**

SCALE NTS

DATE 3/31/19

APPR

STD DWG STRM-14

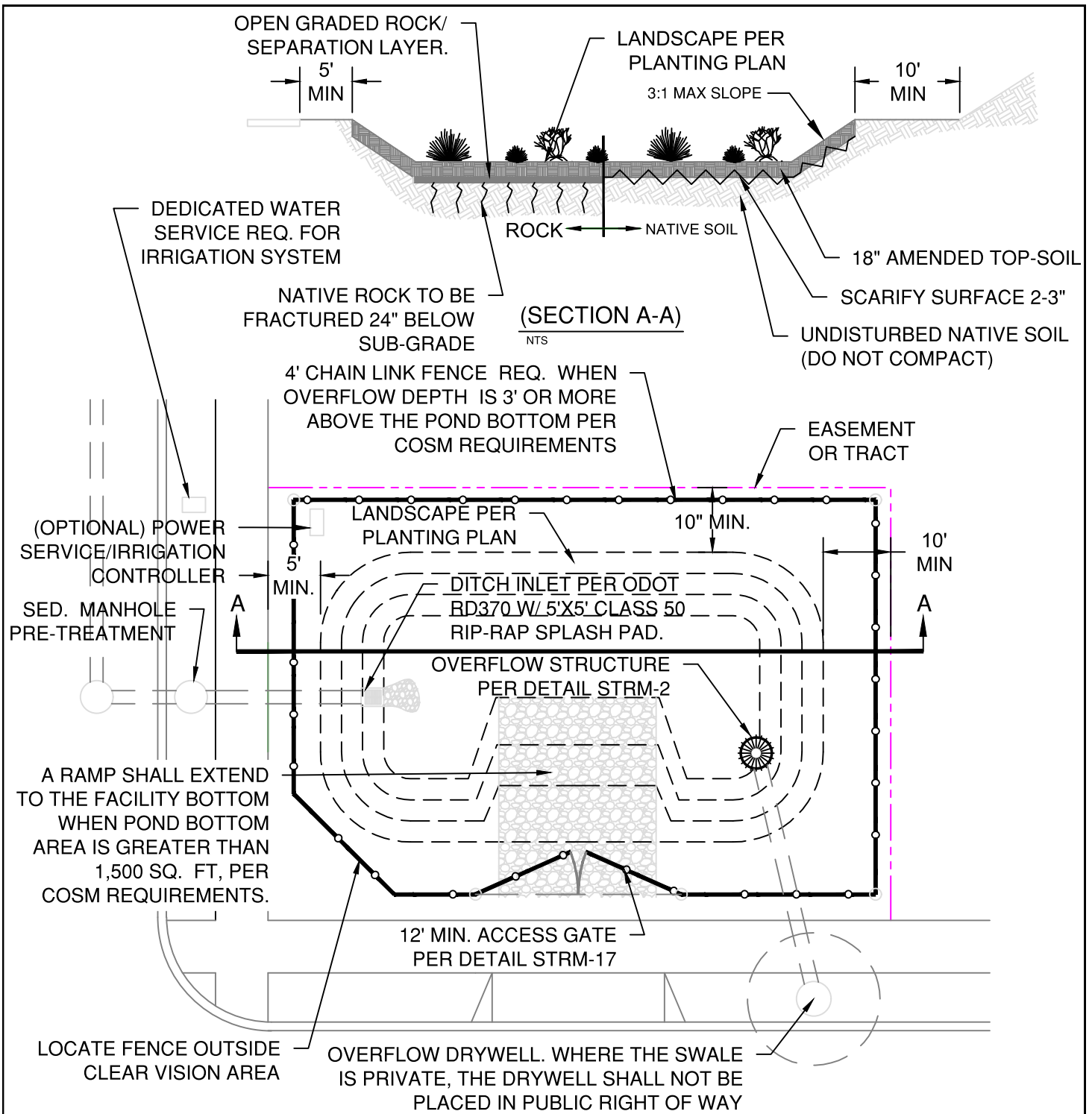

**EXTENDED DETENTION DRY POND (PLAN VIEW)**

NTS

**NOTE:**

THE WATER QUALITY TREATMENT STORM SHOULD DRAIN WITHIN 48 HOURS. IF ADDITIONAL STORAGE IS INCLUDED IN THE POND FOR LARGER STORM EVENTS, THE TOTAL FACILITY SHOULD DRAIN WITHIN 72 HOURS FOLLOWING THE PEAK DESIGN STORM EVENT.

DRAWN CJH	
DIV STORM	
REV	DATE



**CITY OF BEND**

**CITY OF BEND**

STANDARD DRAWING

710 NW WALL ST., BEND, OREGON 97701

**INFILTRATION POND DETAIL**

SCALE NTS

DATE 1/2021

APPR

STD DWG STRM-16

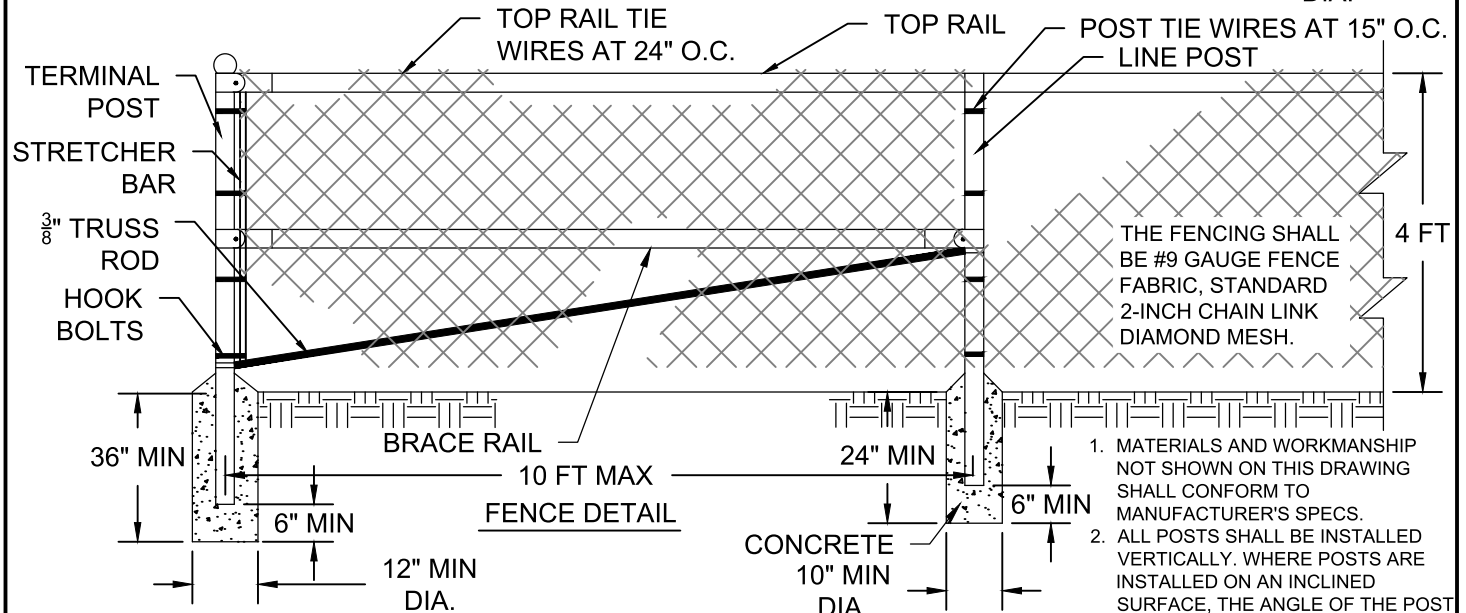
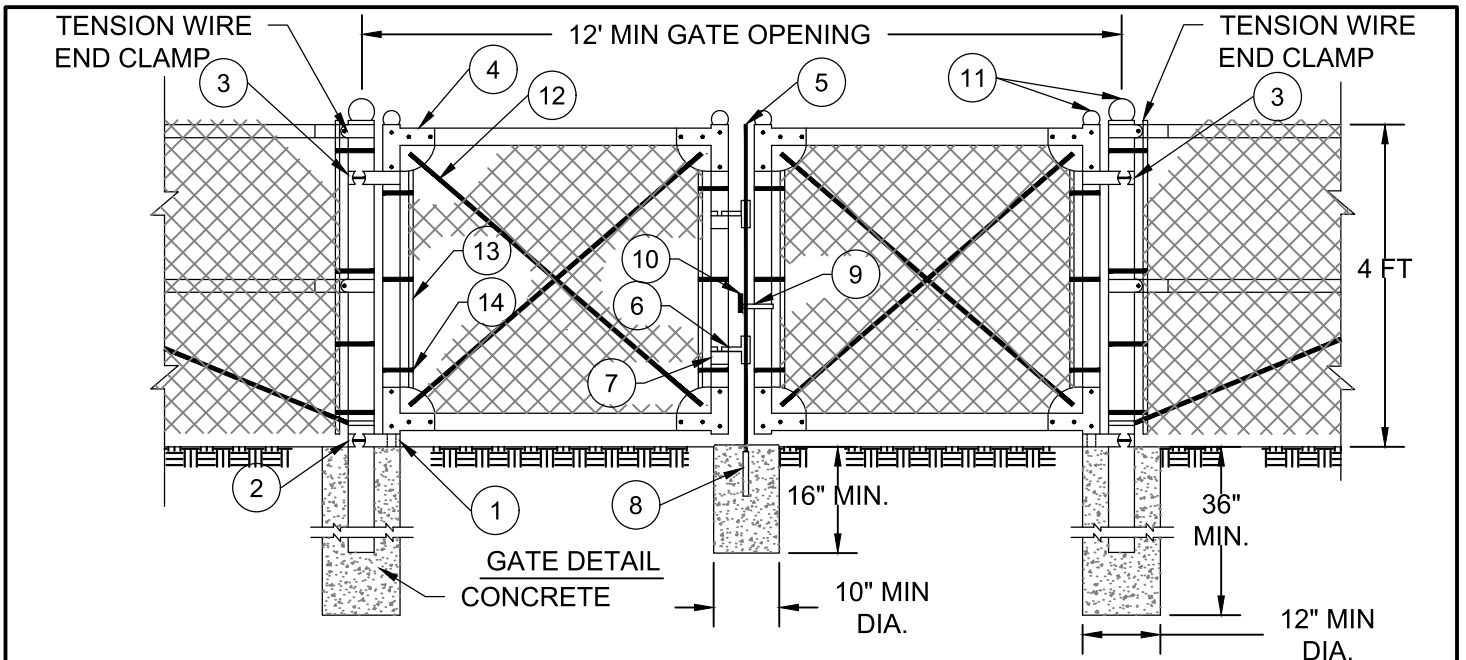

1. MATERIALS AND WORKMANSHIP NOT SHOWN ON THIS DRAWING SHALL CONFORM TO MANUFACTURER'S SPECS.
2. ALL POSTS SHALL BE INSTALLED VERTICALLY. WHERE POSTS ARE INSTALLED ON AN INCLINED SURFACE, THE ANGLE OF THE POST SHALL BE ADJUSTED SO THAT THE POST WILL BE VERTICAL.

PART NO.	DESCRIPTION
1	STRAIGHT PLUG
2	BOTTOM HINGE
3	TOP HINGE
4	CORNER ELBOW
5	PLUNGER ROD
6	LATCH FORK
7	FORK CATCH
8	PLUNGER ROD CATCH
9	LOCK KEEPER GUIDE
10	LOCK KEEPER W/ CITY LOCK
11	ORNAMENTAL TOPS
12	TRUSS RODS
13	STRETCHER BAR
14	HOOK BOLTS

GATE FRAME MEMBERS SIZE & WEIGHT		
GATE LEAF WIDTH OF 6 FT OR LESS	OUTSIDE DIMENSIONS INCHES	WEIGHT LBS/FT
ROUND	1.66	2.27
*ROUND	1.66	1.84
* GRADE B HIGH STRENGTH STEEL		

GATE POST SIZE AND WEIGHT		
GATE LEAF WIDTH OF 6 FT OR LESS	OUTSIDE DIMENSIONS INCHES	WEIGHT LBS/FT
ROUND	2.875	5.79
*ROUND	2.875	4.64
* GRADE B HIGH STRENGTH STEEL		

SHAPE, SIZE AND WEIGHT REQUIREMENTS FOR FENCE POSTS AND RAILS			
ITEM	SHAPE	OUTSIDE DIMENSIONS INCHES	WEIGHT LBS/FT.
TERMINAL POST	ROUND	2.375	3.65
LINE POSTS	*ROUND	2.375	3.12
TOP & BRACE RAILS	ROUND	1.90	2.72
	*ROUND	1.90	2.28
	ROUND	1.66	2.27
	*ROUND	1.66	1.84
* GRADE B HIGH STRENGTH STEEL			
** INCLUDES END, CORNER, ANGLE, INTERSECTION AND INTERMEDIATE BRACED POSTS			

DRAWN A.JD  
 DIV STORM  
 REV DATE



**CITY OF BEND**  
 STANDARD DRAWING  
 710 NW WALL ST., BEND, OREGON 97701

**CHAINLINK FENCE DETAIL**

SCALE NTS  
 DATE 01/31/2022  
 APPR  
 STD DWG STRM-17

---

**CITY OF BEND STANDARD DRAWINGS**

**Water (W)**

---

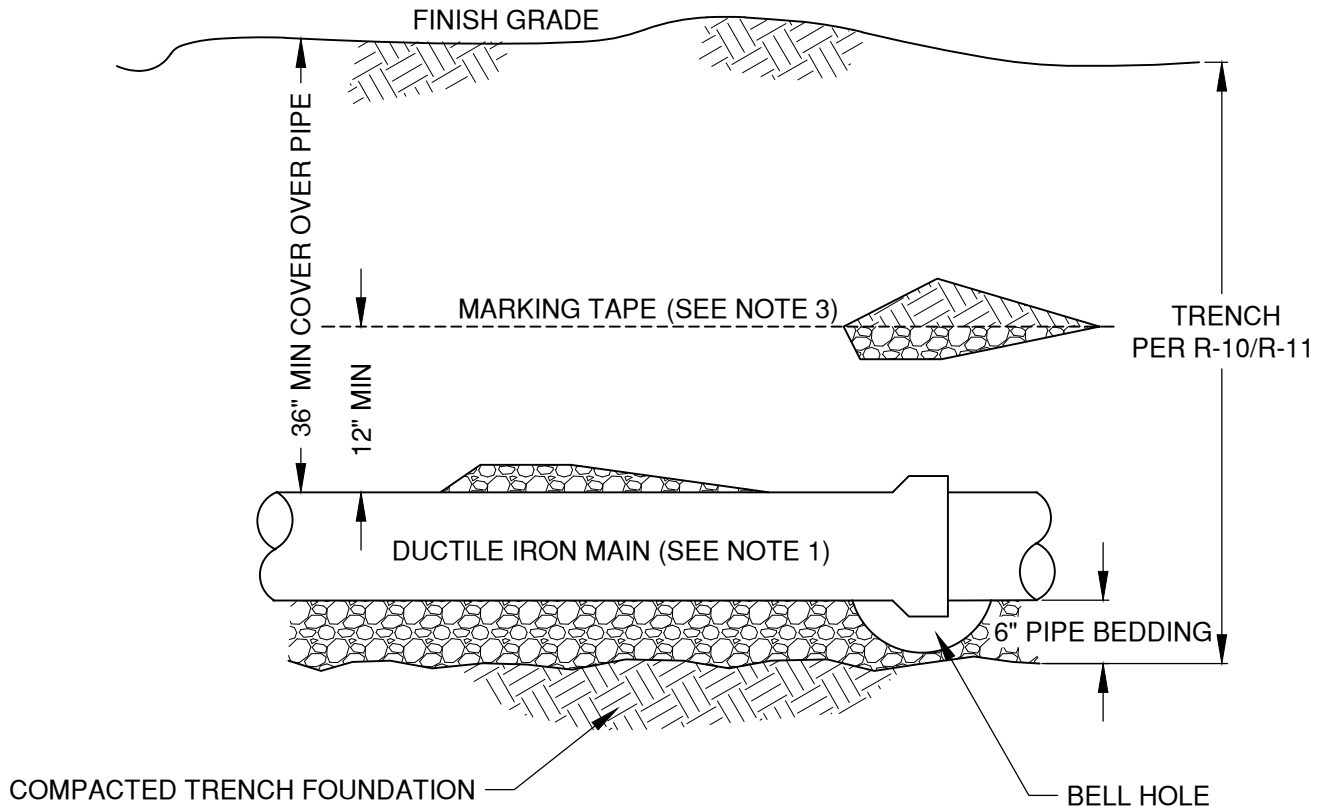

**NOTES:**

1. REFER TO SPECIFICATION SECTION 01140.41 FOR APPROVED PUSH-ON AND MECHANICAL JOINT RESTRAINT SYSTEMS.
2. WOOD BLOCKING IS NOT PERMITTED IN THE BACKFILLED TRENCH.
3. INSTALL MARKING TAPE ON ALL MAINS AND SERVICES PER SPECIFICATION SECTION 01140.10 AND 01140.45.
4. WHEN INSTALLING A WATER LINE THAT CROSSES BELOW OR WITHIN 18 INCHES ABOVE A NON-POTABLE LINE, FOLLOW OAR 333-061-0050(9). ALL NON-POTABLE LINES SHALL BE TREATED AS "SEWER" LINES AS DESCRIBED IN OAR 333-061-0050(9).
5. COMPACTION SHALL MEET REQUIREMENTS OF SPECIFICATION SECTION 00405.46(c)

DRAWN AJD	
DIV WATER	
REV	DATE



**CITY OF BEND**  
 STANDARD DRAWING  
 710 NW WALL ST., BEND, OREGON 97701

SCALE NTS
DATE 01/31/2022
APPR
STD DWG W-1

**WATER MAIN TYPICAL PROFILE**

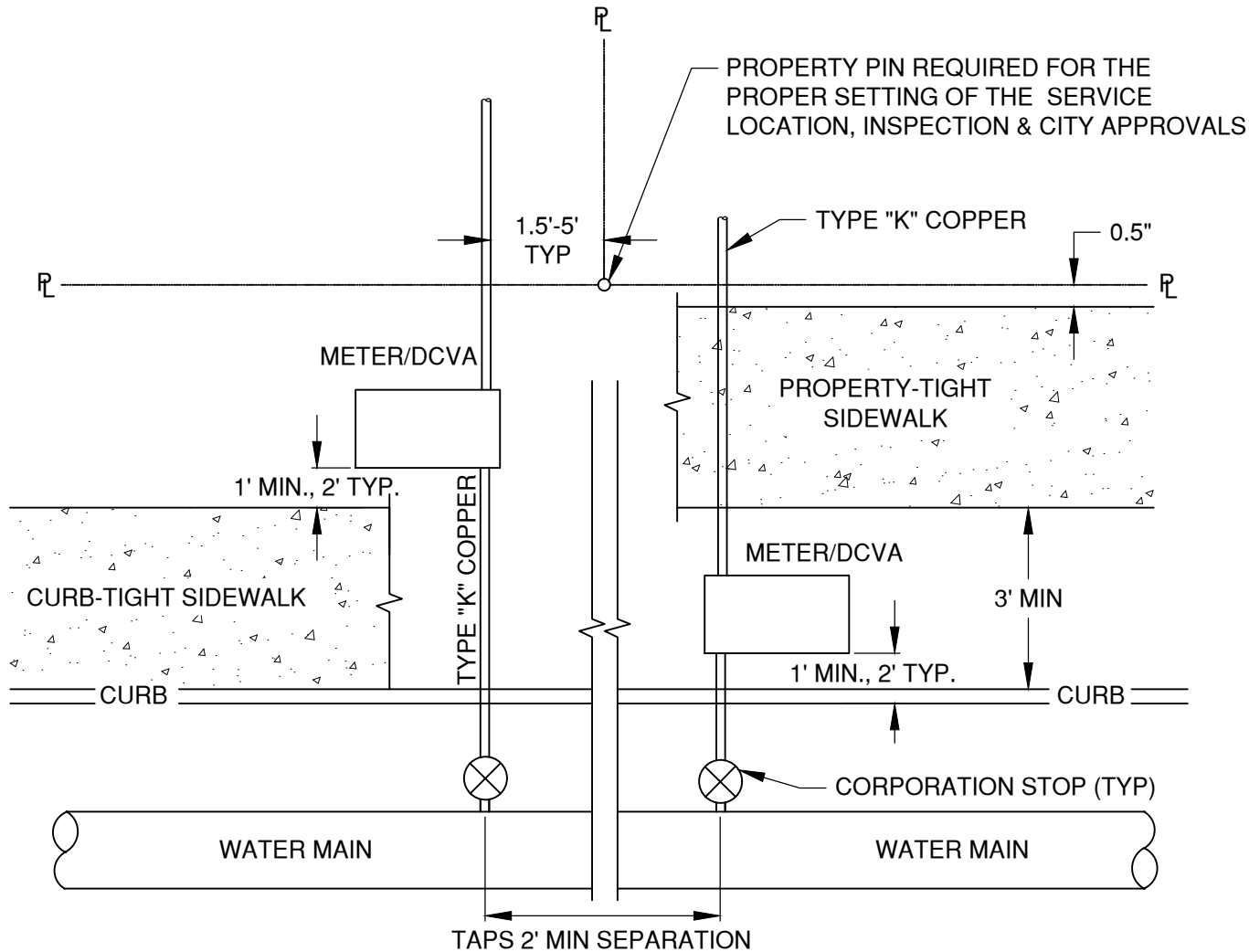

**TWO SERVICES SHARING ONE DITCH AT PROPERTY LINE**

**NOTE:**

1. WATER METER BOXES SHALL BE LOCATED IN LANDSCAPE AREAS, NOT IN HARDSCAPE (I.E. SIDEWALKS & DRIVEWAYS). EXCEPTIONS REQUIRE APPROVAL OF CITY ENGINEER
2. SET WATER SERVICES A MINIMUM OF 10' FROM ALL SANITARY, FRANCHISE, STORM, AND ELECTRICAL SERVICES.
3. METER SHALL MATCH SERVICE LINE SIZE OR ONE SIZE SMALLER.
4. A 1" TAP NEAR A BELL SECTION SHALL BE SEPARATED FROM THE BELL BY A MINIMUM OF 2'. TAPS LARGER THAN 1" IN SIZE SHALL BE SEPARATED FROM THE BELL BY A MINIMUM OF 3'.
5. WHERE METERS ARE PLACED IN METER BANKS, A PERMANENT ADDRESS TAG PROVIDED BY THE CONTRACTOR SHALL BE PLACED ON THE METER BOX PRIOR TO 1 YEAR WARRANTY RELEASE.
6. IF AN EXISTING METER BOX, METER, OR HARDWARE WITHIN THE METER BOX DOES NOT MEET CURRENT CITY STANDARDS, CORRECTIONS OR REPAIRS SHALL BE MADE PRIOR TO THE METER BEING SET.
7. METER BOX SHALL BE SET ON 6" MIN CLASS B MATERIAL COMPACTED TO 95% OF MAXIMUM DENSITY.

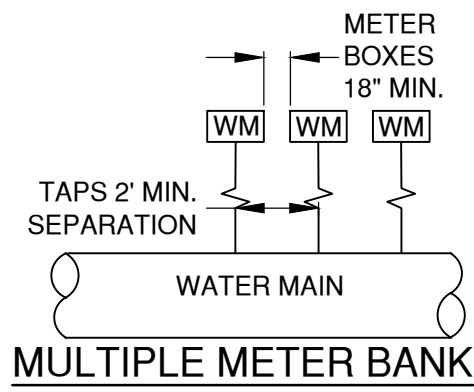

DRAWN AJD	
DIV WATER	
REV	DATE



**CITY OF BEND**  
STANDARD DRAWING  
710 NW WALL ST., BEND, OREGON 97701

**RESIDENTIAL WATER SERVICE INSTALLATION**

SCALE NTS
DATE 01/31/2022
APPR
STD DWG W-4



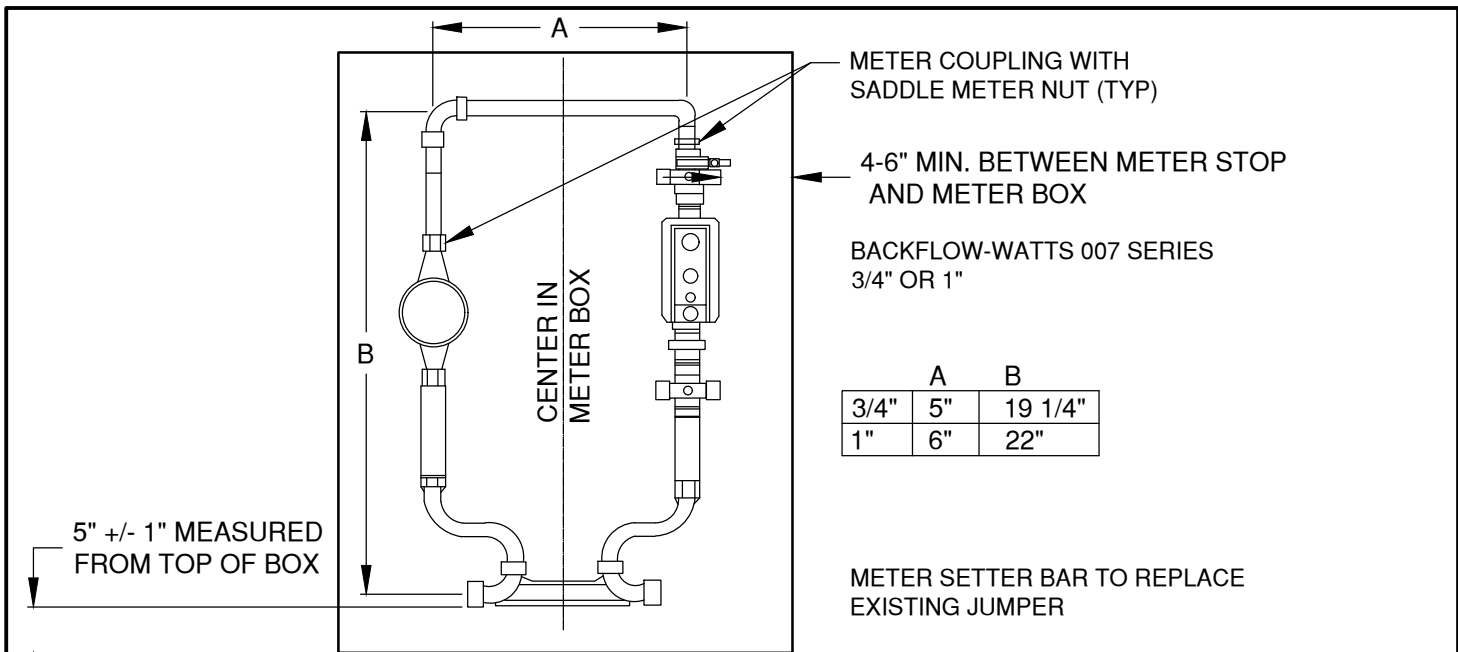

METER COUPLING WITH SADDLE METER NUT (TYP)

4-6" MIN. BETWEEN METER STOP AND METER BOX

BACKFLOW-WATTS 007 SERIES  
3/4" OR 1"

	A	B
3/4"	5"	19 1/4"
1"	6"	22"

METER SETTER BAR TO REPLACE EXISTING JUMPER

**PLAN**

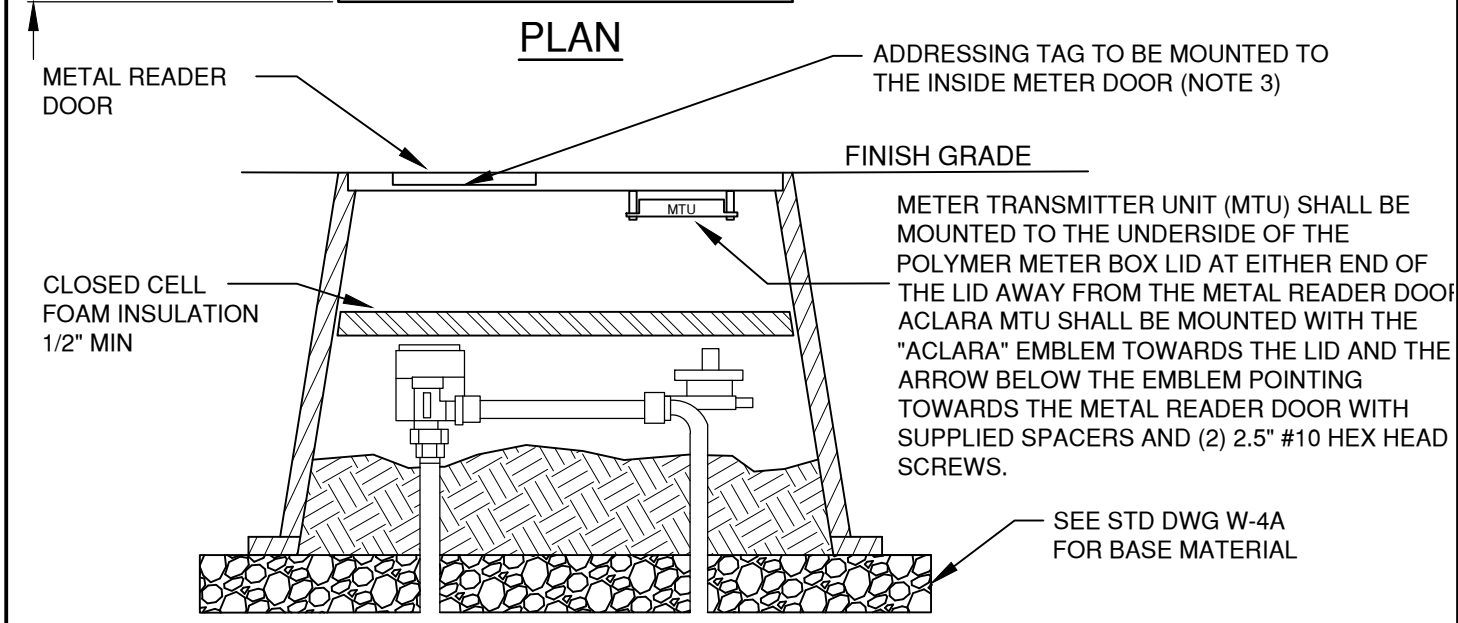

ADDRESSING TAG TO BE MOUNTED TO THE INSIDE METER DOOR (NOTE 3)

FINISH GRADE

METER TRANSMITTER UNIT (MTU) SHALL BE MOUNTED TO THE UNDERSIDE OF THE POLYMER METER BOX LID AT EITHER END OF THE LID AWAY FROM THE METAL READER DOOR. ACLARA MTU SHALL BE MOUNTED WITH THE "ACLARA" EMBLEM TOWARDS THE LID AND THE ARROW BELOW THE EMBLEM POINTING TOWARDS THE METAL READER DOOR WITH SUPPLIED SPACERS AND (2) 2.5" #10 HEX HEAD SCREWS.

SEE STD DWG W-4A FOR BASE MATERIAL

**SECTION**

**OFFSET METER "LOOP" WITH BACKFLOW PREVENTION ASSEMBLY**

NOTES:

1. RESIDENTIAL METER BOXES SHALL BE SET PARALLEL W/THE CURB LINE AND SHALL NOT BE INSTALLED WITHIN SIDEWALK OR PAVED AREAS
2. JUMPER SIZE 1" METER SETTER - 1 1/4"x11" SCHEDULE 80 THREADED NIPPLE (DOMESTIC) DRILLED TO PREVENT FLOW
3. WHERE METER BOXES ARE INSTALLED IN A METER BANK, A BRASS OR STAINLESS STEEL TAG/PLAQUE SHALL BE MOUNTED TO THE INSIDE METER DOOR WITH THE LOT ADDRESS STAMPED PRIOR TO 1 YEAR WARRANTY RELEASE.
4. IF THE METER ASSEMBLY/BOX OR SERVICE LINE IS DAMAGED DURING CONSTRUCTION/SITE IMPROVEMENT ACTIVITIES, DURING THE WARRANTY PERIOD, OR IF THE EXISTING METER BOX OR SERVICE LINE DOES NOT MEET CURRENT CITY STANDARDS, THE DEVELOPER/PROPERTY OWNER SHALL UPGRADE THE COMPONENTS OF THE SERVICE THAT IS OUT OF CONFORMANCE.

DRAWN	AJD
DIV	WATER
REV	DATE



**CITY OF BEND**  
STANDARD DRAWING  
710 NW WALL ST., BEND, OREGON 97701

**3/4"-1" RESIDENTIAL METER SERVICE INSTALLATION**

SCALE	NTS
DATE	11/01/2024
APPR	
STD DWG	W-4B

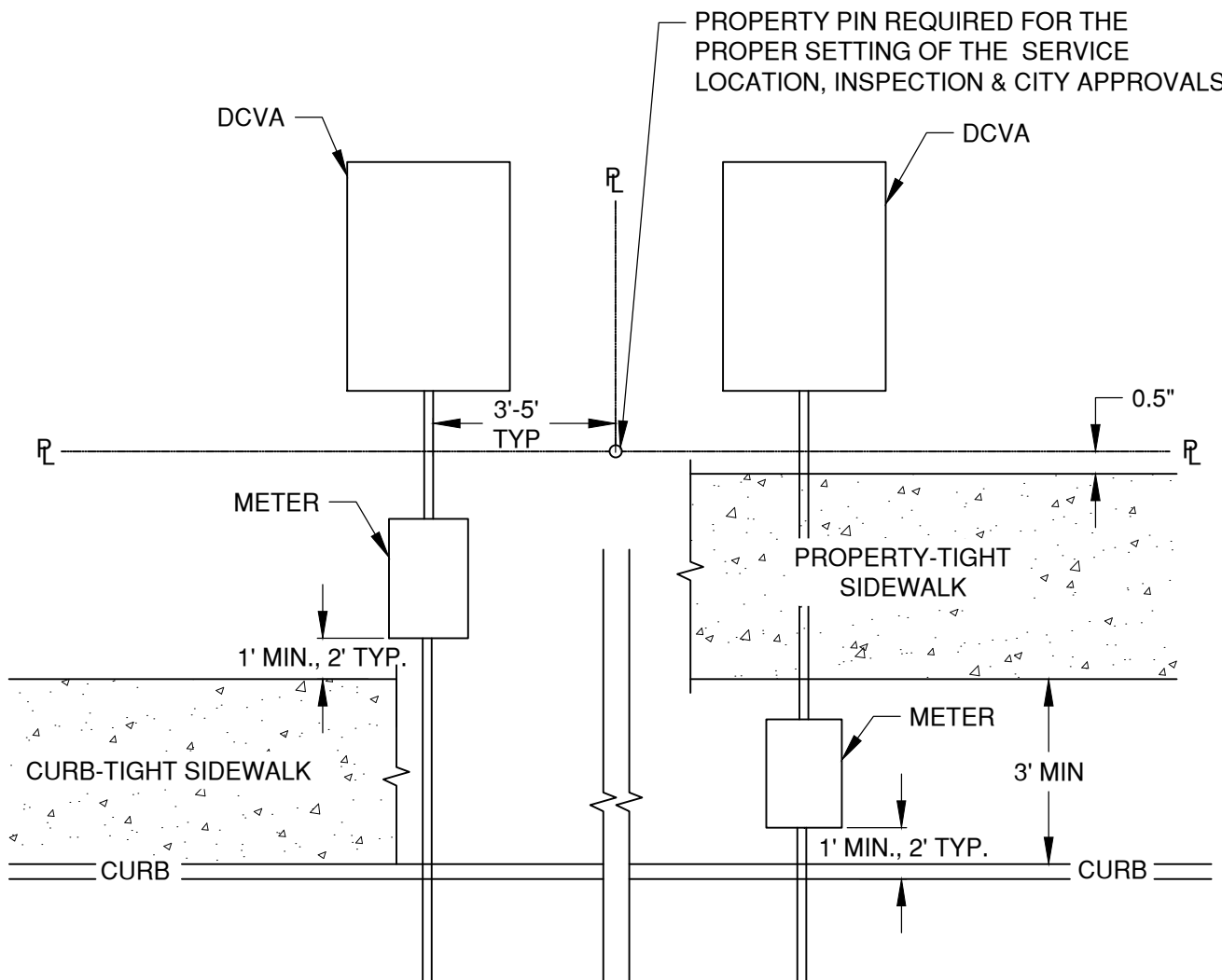

**NOTES:**

1. COMMERCIAL METER BOXES SHALL BE INSTALLED PERPENDICULAR TO THE CURB LINE WITH DOUBLE CHECK VALVE ASSEMBLY TO BE LOCATED ON PRIVATE PROPERTY.
2. WATER METER BOXES SHALL BE LOCATED IN LANDSCAPE AREAS WHEN POSSIBLE, SEE STD DWG W-5E FOR LOCATING METER BOX IN HARD SURFACE.
3. SET WATER SERVICES A MINIMUM OF 10' FROM ALL SANITARY, FRANCHISE, STORM, AND ELECTRICAL SERVICES. ALL TREE WELLS SHALL BE A MINIMUM 6 FEET FROM THE METER BOX INSTALLATION.
4. BACKFLOW PREVENTION DEVICES SHALL BE INSTALLED ON PRIVATE PROPERTY.
5. IF AN EXISTING METER BOX, METER, OR HARDWARE WITHIN THE METER BOX DOES NOT MEET CURRENT CITY STANDARDS, CORRECTIONS OR REPAIRS SHALL BE MADE TO THE EXISTING SERVICE TO MEET CURRENT CITY STANDARDS PRIOR TO THE METER BEING SET.
6. METER BOX SHALL BE SET ON 6" MIN CLASS B MATERIAL COMPACTED TO 95% OF MAXIMUM DENSITY.

DRAWN AJD		<b>CITY OF BEND</b> STANDARD DRAWING 710 NW WALL ST., BEND, OREGON 97701	SCALE NTS
DIV WATER			DATE 01/31/2022
REV DATE			APPR
	<b>CITY OF BEND</b>	<b>COMMERCIAL &amp; IRR METER SERVICE INSTALLATION</b>	STD DWG W-5

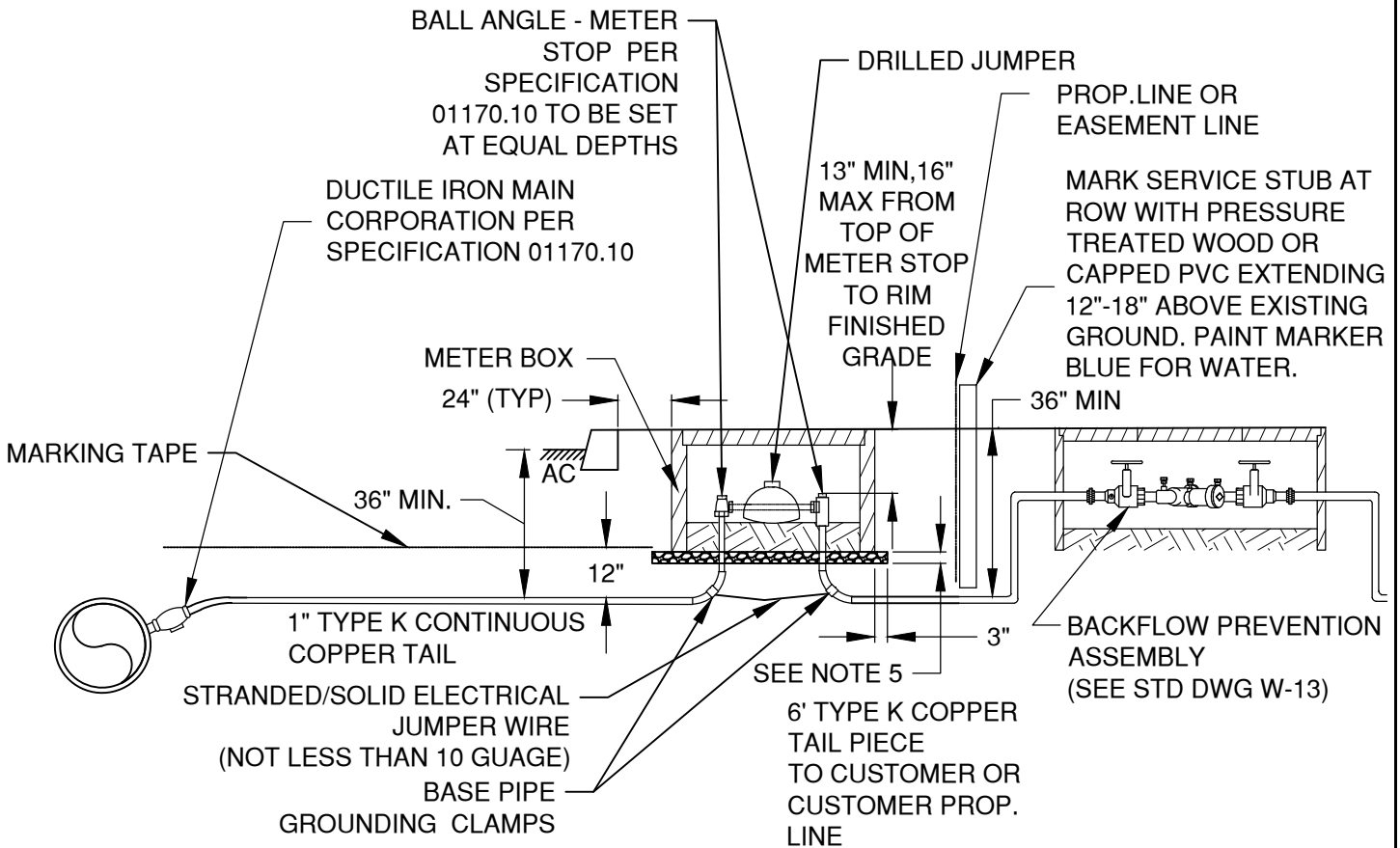

## TYPICAL 1" SERVICE WITH METER

**NOTES:**

1. COMMERCIAL METERS NOT TO BE LESS THAN 1-INCH. METER SIZE TO MATCH SERVICE LINE SIZE.
2. COMMERCIAL METER BOXES SHALL BE INSTALLED PERPENDICULAR TO THE CURB LINE WITH DOUBLE CHECK VALVE ASSEMBLY TO BE LOCATED ON PRIVATE PROPERTY PER STD DWG W-5.
3. COMMERCIAL METERS WILL NOT BE SET UNTIL BACKFLOW PREVENTION ASSEMBLY IS IN PLACE.
4. IF AN EXISTING METER BOX, METER, OR HARDWARE WITHIN THE METER BOX DOES NOT MEET CURRENT CITY STANDARDS, CORRECTIONS OR REPAIRS SHALL BE MADE TO THE EXISTING SERVICE TO MEET CURRENT CITY STANDARDS PRIOR TO THE METER BEING SET.
5. METER BOX SHALL BE SET ON 6" MIN CLASS B MATERIAL COMPACTED TO 95% OF MAXIMUM DENSITY.

DRAWN	AJD
DIV	WATER
REV	DATE



**CITY OF BEND**

**CITY OF BEND**

STANDARD DRAWING

710 NW WALL ST., BEND, OREGON 97701

**1" COMMERCIAL & IRR METER SERVICE INSTALLATION**

SCALE NTS

DATE 11/01/2024

APPR

STD DWG W-5A

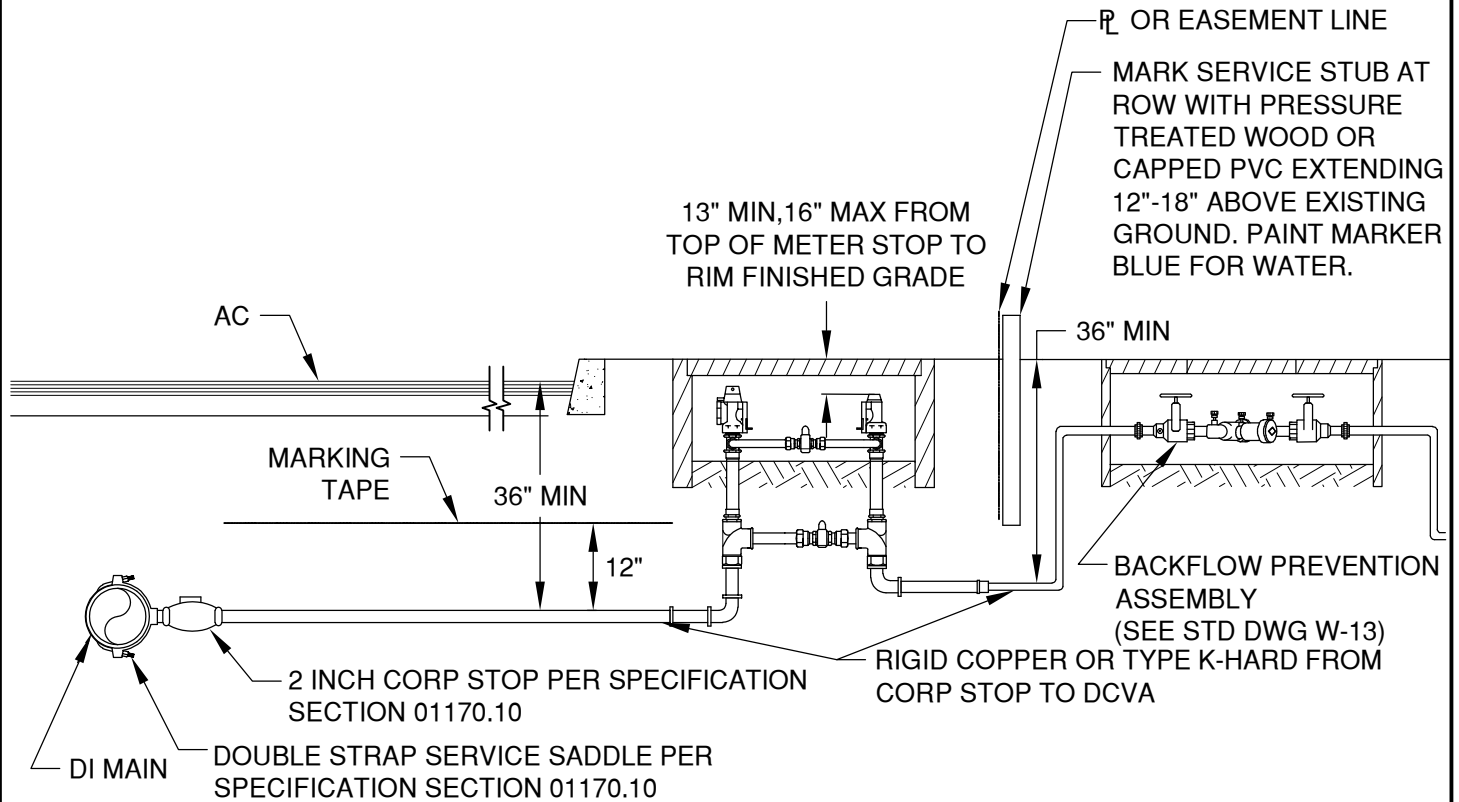

## TYPICAL 2" SERVICE WITH 1-1/2" AND 2" METER

**NOTES:**

1. COMMERCIAL METERS WILL NOT BE SET UNTIL BACKFLOW PREVENTION ASSEMBLY IS IN PLACE
2. COMMERCIAL METER BOXES SHALL BE INSTALLED PERPENDICULAR TO THE CURB LINE WITH DOUBLE CHECK TO BE LOCATED ON PROPERTY
3. ALL METERS LESS THAN 2" WHEN USING A 2" SERVICE LINE ARE TO BE REDUCED WITHIN THE 2" METER SETTER
4. IF AN EXISTING METER BOX, METER, OR HARDWARE WITHIN THE METER BOX DOES NOT MEET CURRENT CITY STANDARDS CORRECTIONS OR REPAIRS SHALL BE MADE TO THE EXISTING SERVICE TO MEET CURRENT CITY STANDARDS PRIOR TO THE METER BEING SET.
5. DOUBLE CHECK ASSEMBLY SHALL BE INSTALLED USING THE UNIFORM BUILDING CODE (UBC) AND SHALL BE LOCATED ON A PRIVATE PROPERTY. THE ABOVE DIAGRAM IS FOR REFERENCE ONLY AND IS SUBJECT TO CHANGE BASED ON A REVIEW BY THE UBC PLANS EXAMINER.
6. METER BOX SHALL BE SET ON 6" MIN CLASS B MATERIAL COMPACTED TO 95% OF MAXIMUM DENSITY

DRAWN AJD		<b>CITY OF BEND</b>	SCALE NTS
DIV WATER		STANDARD DRAWING	DATE 11/01/2024
REV DATE		710 NW WALL ST., BEND, OREGON 97701	APPR
	<b>CITY OF BEND</b>	<b>1 1/2" &amp; 2" COMMERCIAL AND IRRIGATION METER SERVICE INSTALLATION</b>	STD DWG W-5B



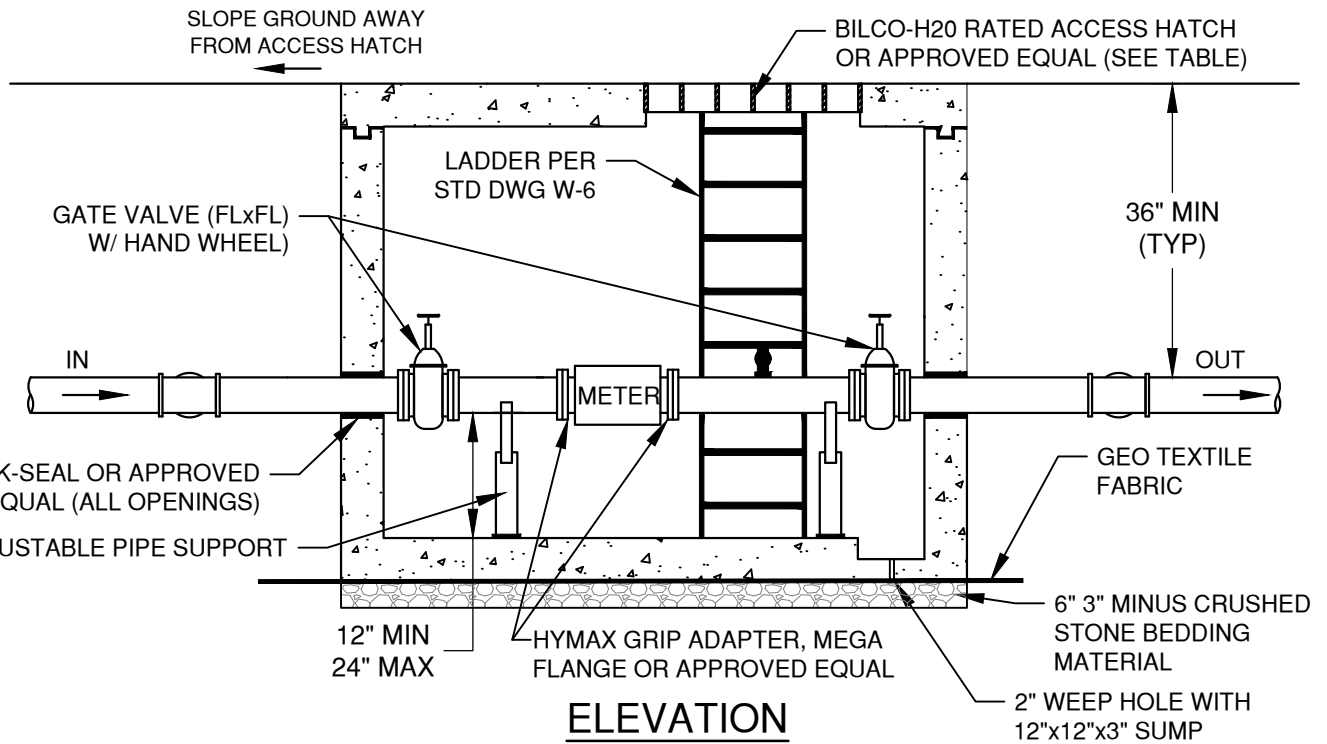
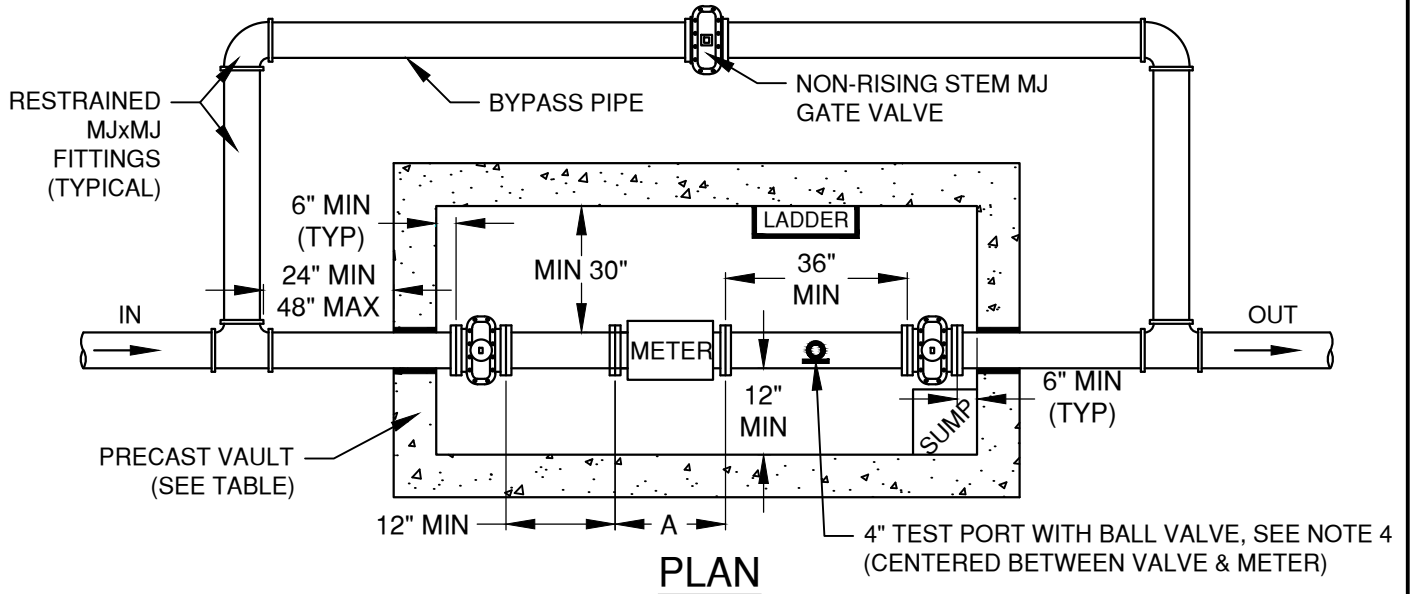

**NOTES:**

1. CONTRACTOR TO BRING ERT'S TO PUBLIC WORKS FOR INSTALLATION AND INSPECTION
2. ENGINEER TO PROVIDE PIPE RESTRAINT DETAIL ENTERING & EXITING VAULT
3. METER SIZE TO MATCH SERVICE SIZE OR ONE SIZE SMALLER.
4. WHERE THE METER DOES NOT PROVIDE A TEST PORT, A 4" TEST PORT SHALL BE INSTALLED WITH 4" TAPPING SADDLE, 4" BRASS BALL VALVE, AND 4" BRASS NIPPLE.

METER (INCH)	BYPASS (INCHES)	VAULT*	BILCO DOOR	A (INCHES)
6"	4"	810-LA	J-5AL	15"±
8"	6"	810-LA	JD-3AL	17"±
10"	8"	612-LA	JD-3AL	20"±
12"	12"	612-LA	JD-3AL	24"±

\* VAULT SIZES MAY VARY BY ENGINEER DESIGN PROVIDE MIN DIMENSIONS ARE MAINTAINED

DRAWN AJD  
DIV WATER  
REV DATE



CITY OF BEND

**CITY OF BEND**

STANDARD DRAWING

710 NW WALL ST., BEND, OREGON 97701

**6" AND LARGER COMMERCIAL METER INSTALLATION**

SCALE NTS

DATE 01/31/2022

APPR

STD DWG W-5D

SIDEWALK INSTALLATION WITHIN 5' PUBLIC ACCESS EASEMENT AS REQUIRED BY BEND CENTRAL DISTRICT. MAY NOT BE APPLICABLE FOR ALL PROJECTS.

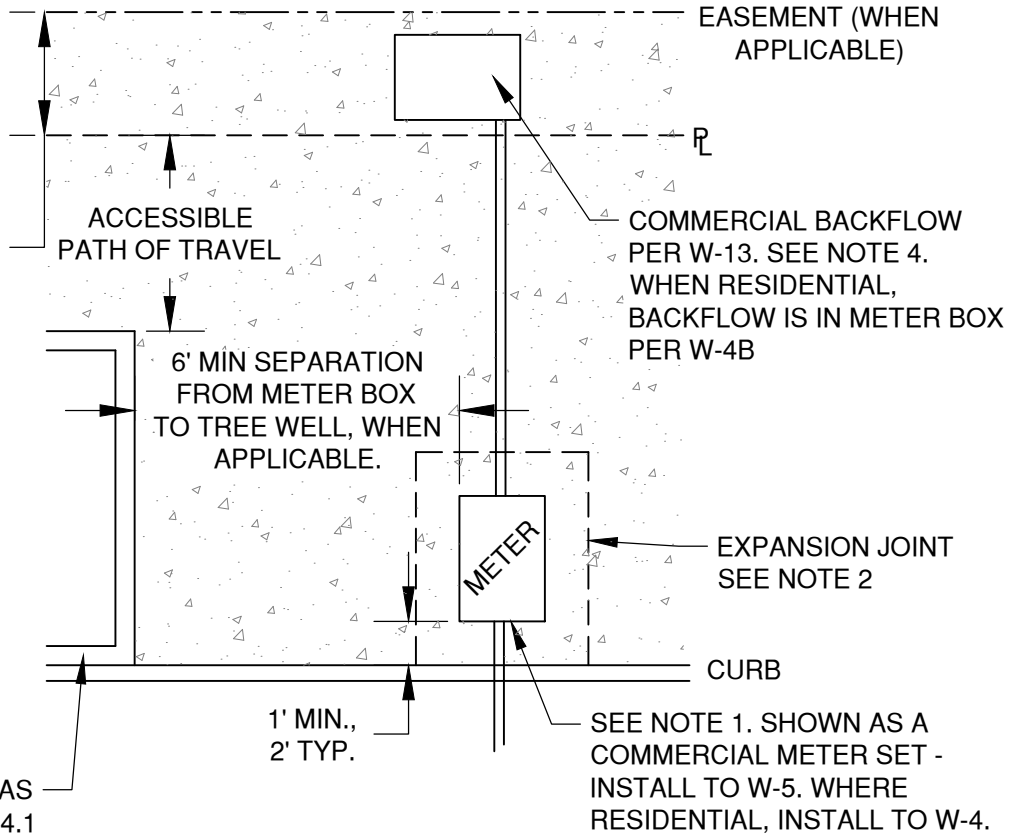

TREE WELL, MIN 4'X9' AS APPLICABLE. REFER TO 12.2.4.1 OF THE CONSTRUCTION DESIGN STANDARDS

TYPICAL INSTALLATION IN THE BEND CENTRAL DISTRICT OR WHERE WIDENED SIDEWALKS ARE REQUIRED BY DEVELOPMENT CODE. METERS TO BE PERMITTED WITHIN HARDSCAPE ONLY WHEN APPROVED BY THE CITY ENGINEER.

**NOTE:**

1. WATER METER BOXES SHALL BE LOCATED IN LANDSCAPE AREAS WHEN POSSIBLE. IF WATER METER BOX CAN BE LOCATED ON PRIVATE PROPERTY TO REMOVE IT FROM SIDEWALK, A UTILITY EASEMENT SHALL BE GRANTED TO THE CITY TO MAINTAIN THE METER.
2. AN EXPANSION JOINT IN THE SIDEWALK SHALL BE INSTALLED 12-INCH AROUND THE ENTIRE PERIMETER OF THE METER BOX.
3. STATE SPEC BASE ROCK SHALL BE COMPACTED TO 95% IMMEDIATELY BELOW AND FOR A MINIMUM OF 3 FEET AROUND THE METER BOX.
4. BACKFLOW DEVICE SHALL BE INSTALLED ON PRIVATE PROPERTY. WHERE BACKFLOW DEVICES CANNOT BE PLACED WITHIN LANDSCAPE, THE BOX SHALL BE INSTALLED OUTSIDE THE RIGHT OF WAY AND OUTSIDE A PUBLIC UTILITY EASEMENT. INSTALLATION OF BACKFLOW DEVICES WITHIN A BUILDING WILL BE GRANTED ON A CASE BY CASE BASIS BY THE CITY ENGINEER ONLY WHERE IT CAN BE ADEQUATELY SHOWN NOT TO FIT OUTSIDE THE BUILDING (EXAMPLE, THE BACKFLOW DEVICE, AND THEREFORE THE VAULT, IS TOO LARGE TO FIT)
5. SET WATER SERVICES A MINIMUM OF 10' FROM ALL SANITARY, FRANCHISE, STORM, AND ELECTRICAL SERVICES. ALL TREE WELLS SHALL BE A MINIMUM 6 FEET FROM THE METER BOX INSTALLATION.
6. WATER METERS SHALL NOT BE PLACED WITHIN VEHICULAR SURFACES (DRIVEWAYS) WITHOUT CITY ENGINEER APPROVAL.
7. COMMERCIAL WATER METER BOXES TO BE INSTALLED PERPENDICULAR TO THE CURB LINE, SEE STD DWG W-5. RESIDENTIAL WATER METER BOXES TO BE INSTALLED PARALLEL TO THE CURB LINE PER STD DWG W-4

DRAWN	AJD
DIV	WATER
REV	DATE



**CITY OF BEND**

**CITY OF BEND**

STANDARD DRAWING

710 NW WALL ST., BEND, OREGON 97701

**METER INSTALLATION IN SIDEWALKS**

SCALE NTS

DATE 01/31/2022

APPR

STD DWG W-5E

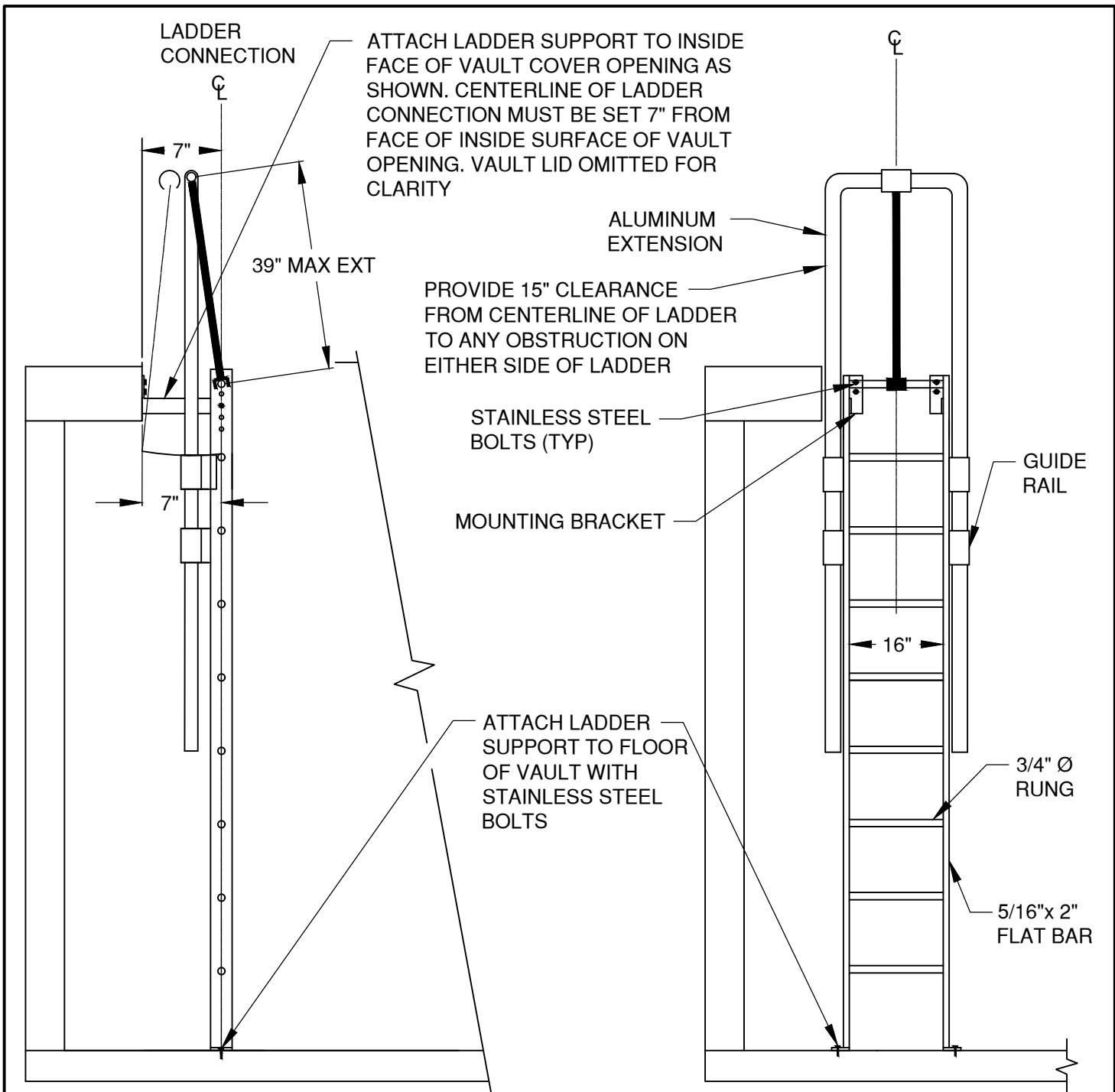

**SIDE VIEW**

**FRONT VIEW**

**NOTES:**

1. GALVANIZED LADDER W/AN ALUMINUM EXTENSION BY OLDCASTLE (OR APPROVED EQUAL) (PER OAR 437, DIV 2, CODE OF FEDERAL REGULATIONS, TITLE 29, CHAPTER XVII PART 1910.27)
2. 5'-4" GALVANIZED LADDER FROM OLDCASTLE TO BE CUT DOWN TO 4'-7" BY CONTRACTOR FOR USE IN VAULT 675-WA. OLDCASTLE TO SUPPLY 49 1/2" ALUMINUM EXTENSION

DRAWN AJD	
DIV WATER	
REV	DATE



**CITY OF BEND**

**CITY OF BEND**

STANDARD DRAWING

710 NW WALL ST., BEND, OREGON 97701

**GALV. LADDER W/ ALUM EXT FOR WATER VAULTS**

SCALE NTS

DATE 01/31/2022

APPR

STD DWG W-6

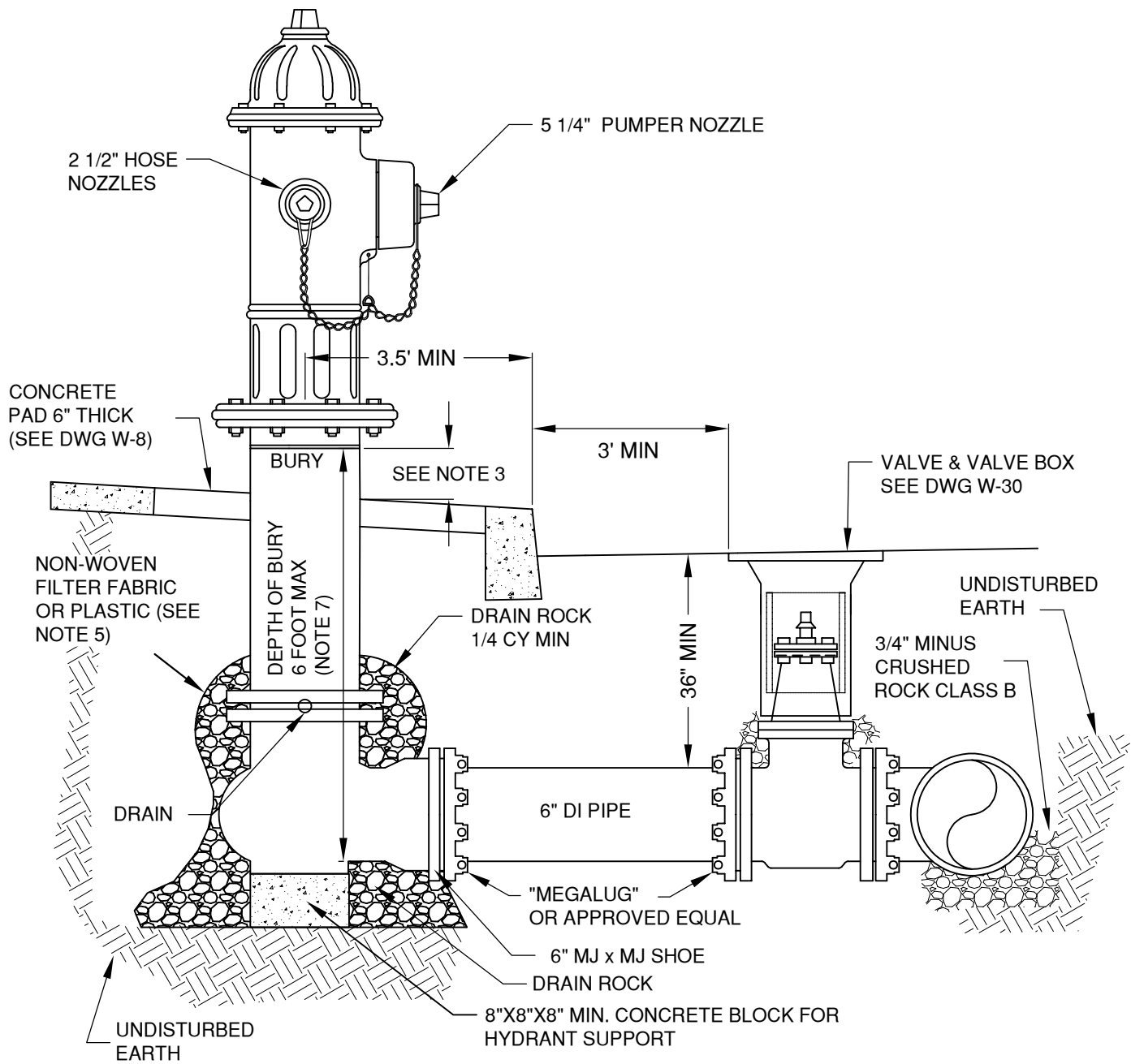

**NOTES:**

1. ALL PIPES SHALL HAVE RESTRAINED JOINTS.
2. MJ x MJ TEE OR MJxMJxSWIVEL (REQUIRES ENGINEER APPROVAL) WITH 6-INCH VALVE AT THE MAINLINE.
3. FINISH GRADE OF HYDRANT SHALL BE SET AT BURY LINE TO A MAXIMUM OF 3" BELOW BURY LINE FOR NEW INSTALLATION AND MAX OF 6" FOR RETROFITS. NO HYDRANT EXTENSIONS PERMITTED ON NEW INSTALLATIONS.
4. SET HYDRANT PLUMB. COMPACT ALL BACKFILL PER SPECIFICATIONS.
5. NON-WOVEN SEPARATION FILTER FABRIC OR PLASTIC (OSS TABLE 02320-4) INSTALLED BETWEEN UNDISTURBED EARTH AND DRAINROCK PRIOR TO BACKFILL.
6. HYDRANTS SHALL BE MANUFACTURER'S RED. NO OTHER COLOR IS PERMITTED.
7. USE 45 DEGREE OR 22.5 DEGREE BENDS TO ADJUST ACCORDINGLY TO ACHIEVE MAX DEPTH REQUIREMENT.

DRAWN CJH	
DIV WATER	
REV	DATE



**CITY OF BEND**  
 STANDARD DRAWING  
 710 NW WALL ST., BEND, OREGON 97701

**TYPICAL HYDRANT**

SCALE NTS
DATE 11/01/2024
APPR
STD DWG W-7

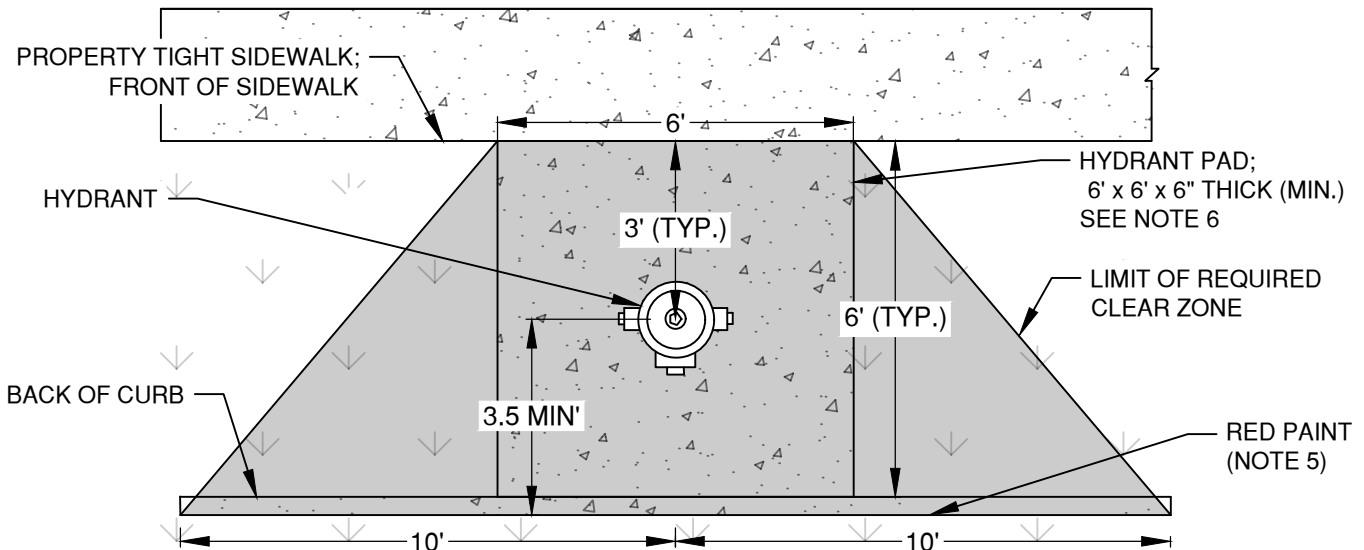

**PROPERTY TIGHT SIDEWALK HYDRANT LOCATION AND CLEAR ZONE  
PLAN VIEW**

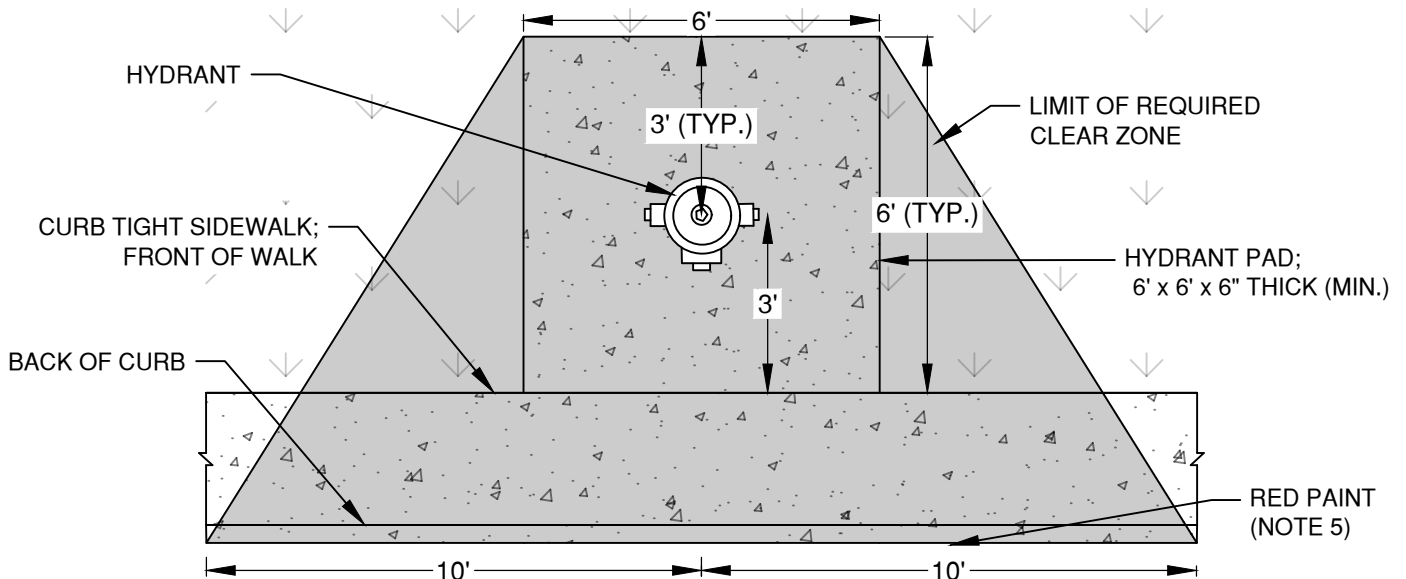

**CURB TIGHT SIDEWALK HYDRANT LOCATION AND CLEAR ZONE  
PLAN VIEW**

**NOTES:**

1. THE CLEAR ZONE PROHIBITS PARKING, FENCES, TREES, RETAINING WALLS, OR OTHER STRUCTURES THAT COULD INTERFERE WITH OPERATION OF HYDRANT. GRASS, MULCH, BARKDUST, AND GROUND COVER IS PERMITTED.
2. PROPERTY OWNERS SHOULD BE AWARE THAT GROUND COVER COULD BE DAMAGED WHEN THE HYDRANT IS USED OR WHEN HYDRANT MAINTENANCE IS PERFORMED.
3. CONCRETE PADS ARE TO BE A MINIMUM OF 6" THICK AND BE POURED AND PLACED ON 2" MIN. COMPACTED BASE ROCK PER SECTION OSS 00405.00
4. THERE SHALL BE A MINIMUM 4 FOOT CLEAR TRAVEL WIDTH ON SIDEWALKS ADJACENT TO HYDRANTS.
5. THE CURB SHALL BE PAINTED RED FOR A TOTAL OF 20 FEET, CENTERED ON THE HYDRANT.
6. HYDRANT PAD TO EXTEND FROM CURB TO SIDEWALK WITH NO LANDSCAPE GAP UNLESS 5 FOOT MINIMUM LANDSCAPE WIDTH CAN BE PROVIDED.

DRAWN CJH	
DIV WATER	
REV	DATE



**CITY OF BEND**

**CITY OF BEND**

STANDARD DRAWING

710 NW WALL ST., BEND, OREGON 97701

**HYDRANT LOCATION AND CLEAR ZONE**

SCALE NTS

DATE 11/01/2024

APPR

STD DWG W-8

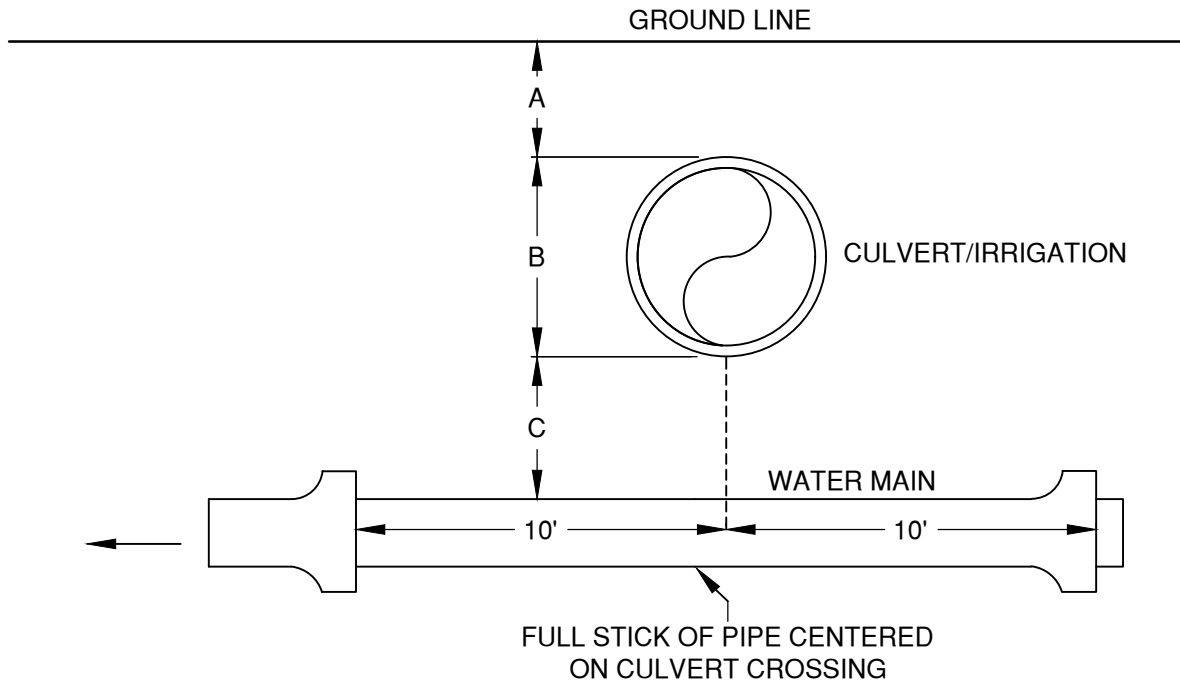

A

B

C

COVER FROM CULVERT TO FINISH GRADE	CULVERT SIZE	SEPARATION CULVERT TO MAIN
12" OR LESS	6" THRU 12"	NOT LESS THAN 18"
12" OR MORE	6" THRU 12"	NOT LESS THAN 12"
12" OR LESS	14" THRU 24"	NOT LESS THAN 30"
12" OR MORE	14" THRU 24"	NOT LESS THAN 24"
	GREATER THAN 24"	NOT LESS THAN 36"

DRAWN AJD  
 DIV WATER  
 REV DATE



CITY OF BEND

CITY OF BEND

STANDARD DRAWING

710 NW WALL ST., BEND, OREGON 97701

SCALE NTS

DATE 01/31/2022

APPR

STD DWG W-9

SEPARATION OF WATER LINE TO IRRIGATION CULVERTS

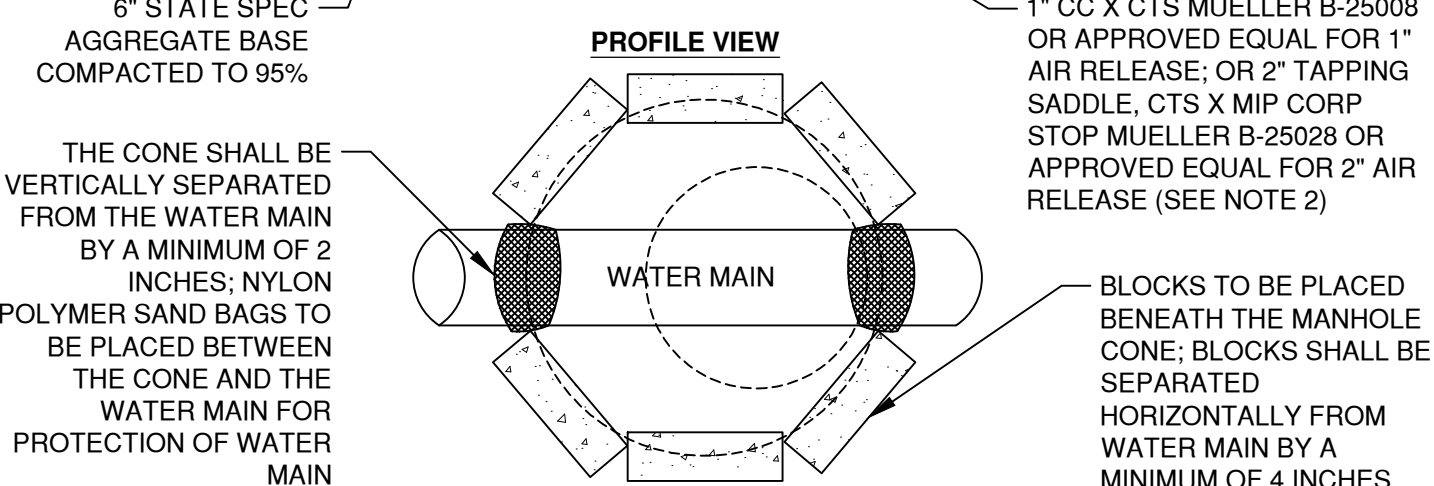
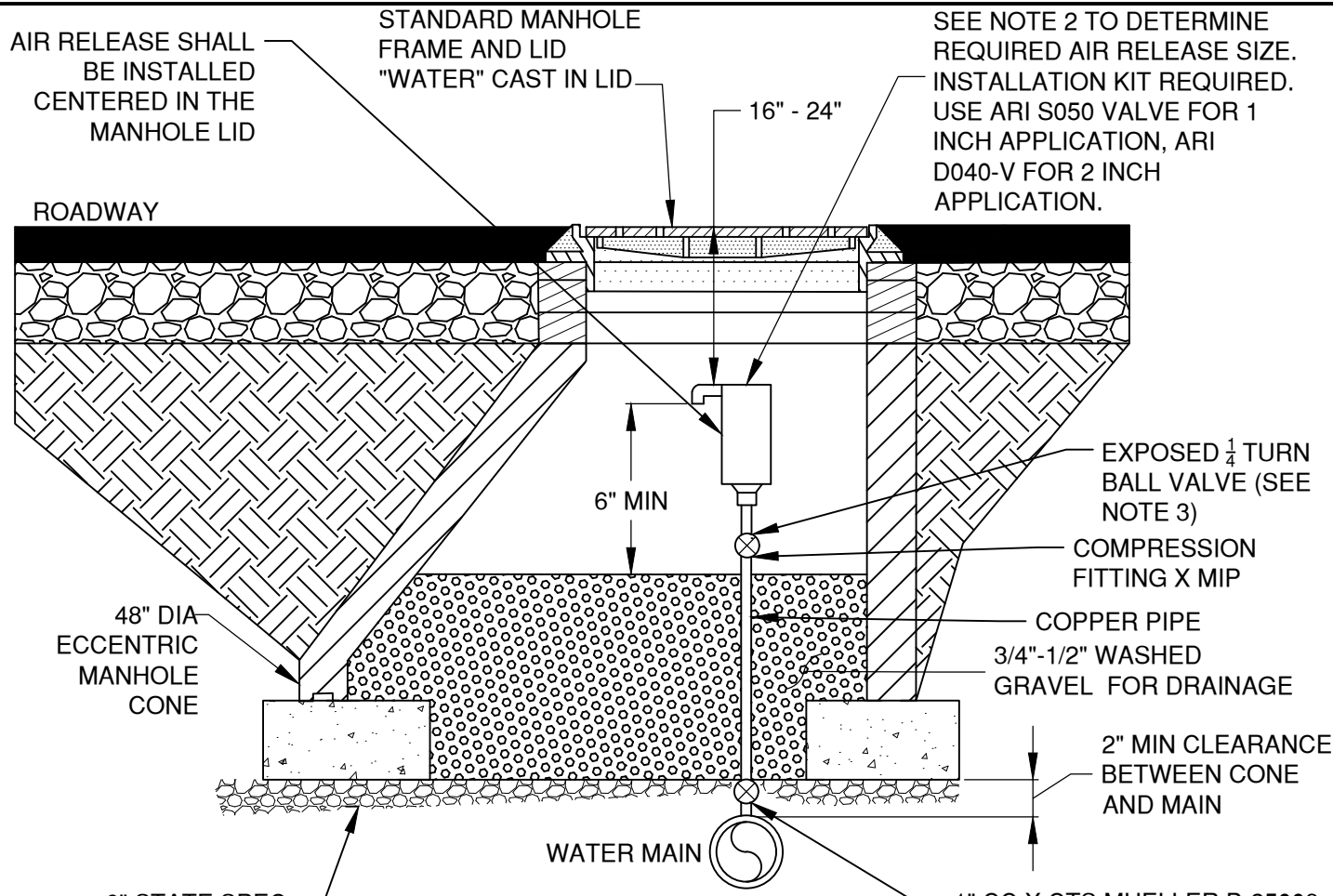

- GENERAL NOTES:**
1. AIR RELEASE OR COMBINATION VALVES SHALL BE INSTALL AT ALL HIGH POINTS. WHERE THE HIGH POINT IS AT THE TOP OF A LONG ASCENT (1,250 FEET+) A COMBINATION AIR/VACUUM VALVE SHALL BE INSTALLED.
  2. 1-INCH AIR RELEASE VALVE TO BE USED ON WATER MAINS LESS THAN OR EQUAL TO 12-INCH DIAMETER. 2-INCH AIR RELEASE VALVE TO BE USED ON WATER MAINS GREATER THAN 12-INCH DIAMETER.
  3. WHEN THE DISTANCE BETWEEN THE AIR VALVE AND THE CORP AT THE MAIN IS LESS THAN 18 INCHES, THE BALL VALVE MAY BE OMITTED.

DRAWN	AJD
DIV	WATER
REV	DATE



**CITY OF BEND**  
 STANDARD DRAWING  
 710 NW WALL ST., BEND, OREGON 97701

**1" & 2" STANDARD AIR RELEASE VALVE - TRAFFIC AREA**

SCALE	NTS
DATE	11/01/2024
APPR	
STD DWG	W-10

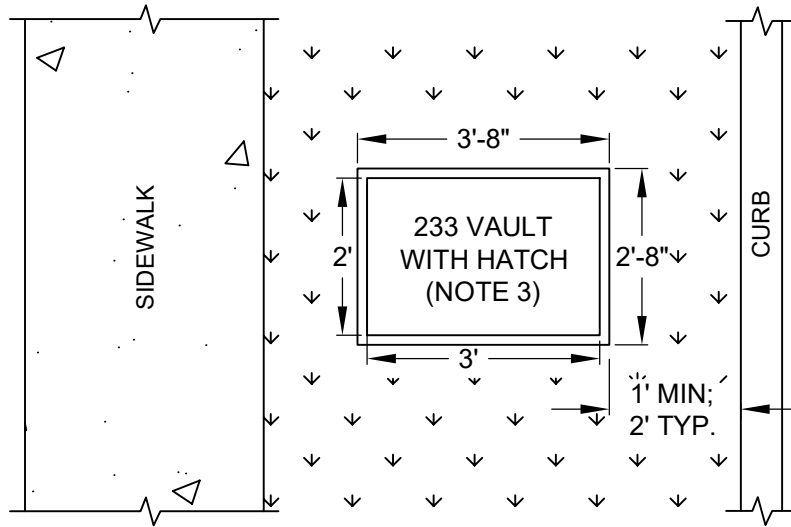

**AIR RELEASE VALVE LOCATION  
PLAN VIEW**

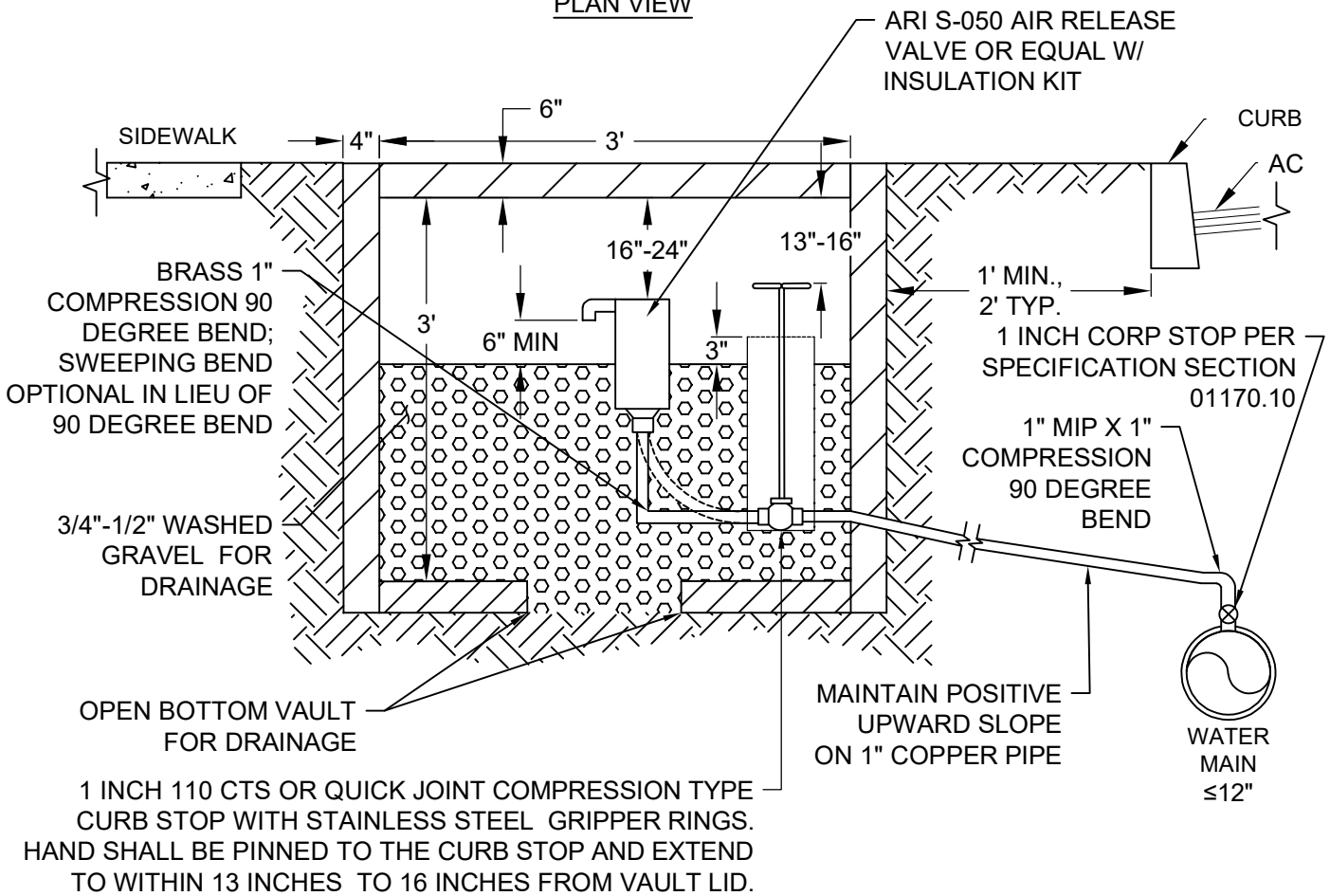

**GENERAL NOTES:**

1. AIR RELEASE OR COMBINATION VALVES SHALL BE INSTALL AT ALL HIGH POINTS. WHERE THE HIGH POINT IS AT THE TOP OF A LONG ASCENT (1,250 FEET+) A COMBINATION AIR/VACUUM VALVE SHALL BE INSTALLED.
2. IF 1" AIR RELEASE VALVE IS INSTALLED IN TRAFFIC AREA, INSTALL PER STD DWG W-10.
3. VAULT SHALL BE PRECAST VAULT WITH 2'X3' HATCH AND OPEN BOTTOM, OR APPROVED EQUAL.

DRAWN	AJD
DIV	WATER
REV	DATE



CITY OF BEND

**CITY OF BEND**

STANDARD DRAWING

710 NW WALL ST., BEND, OREGON 97701

**1" STANDARD AIR RELEASE VALVE**

SCALE NTS

DATE 11/01/2024

APPR

STD DWG W-10A

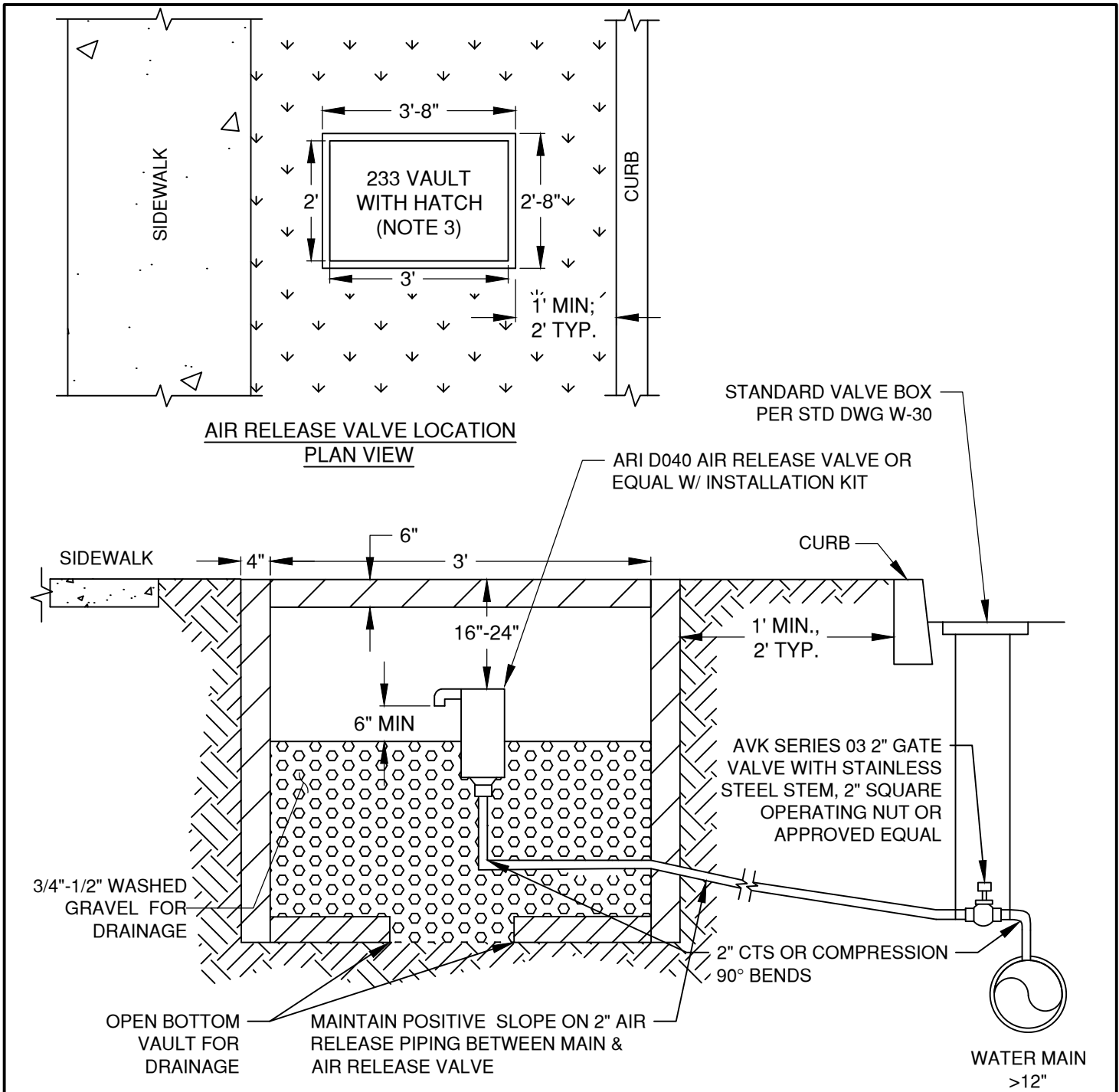

**GENERAL NOTES:**

1. AIR RELEASE OR COMBINATION VALVES SHALL BE INSTALL AT ALL HIGH POINTS. WHERE THE HIGH POINT IS AT THE TOP OF A LONG ASCENT (1,250 FEET+) A COMBINATION AIR/VACUUM VALVE SHALL BE INSTALLED.
2. SEE STD DWG W-10 FOR 2" AIR RELEASE VALVES LOCATED IN TRAFFIC AREAS.
3. VAULT SHALL BE ADVANCED PRECAST PRODUCT 233 VAULT WITH 2'X3' HATCH AND OPEN BOTTOM, OR APPROVED EQUAL.

DRAWN AJD			<p align="center"><b>CITY OF BEND</b></p> <p align="center">STANDARD DRAWING</p> <p align="center">710 NW WALL ST., BEND, OREGON 97701</p>	SCALE NTS
DIV WATER				DATE 11/01/2024
REV	DATE			APPR
CITY OF BEND			<b>2" STANDARD AIR RELEASE VALVE</b>	STD DWG W-10B

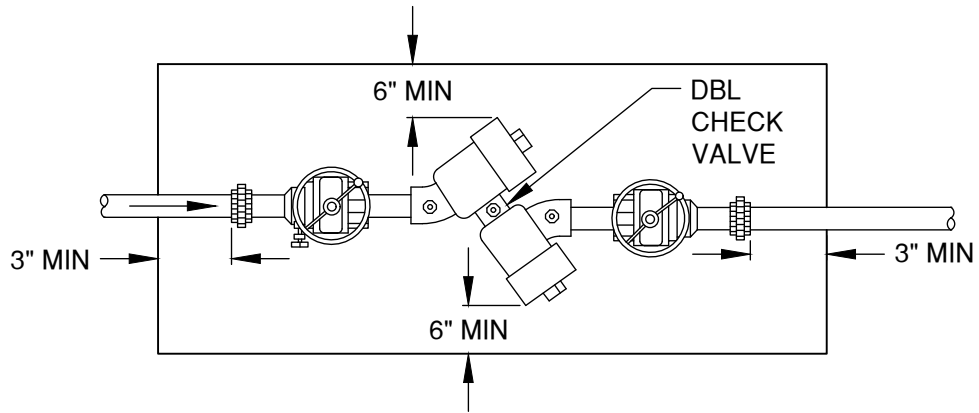

**TOP VIEW**

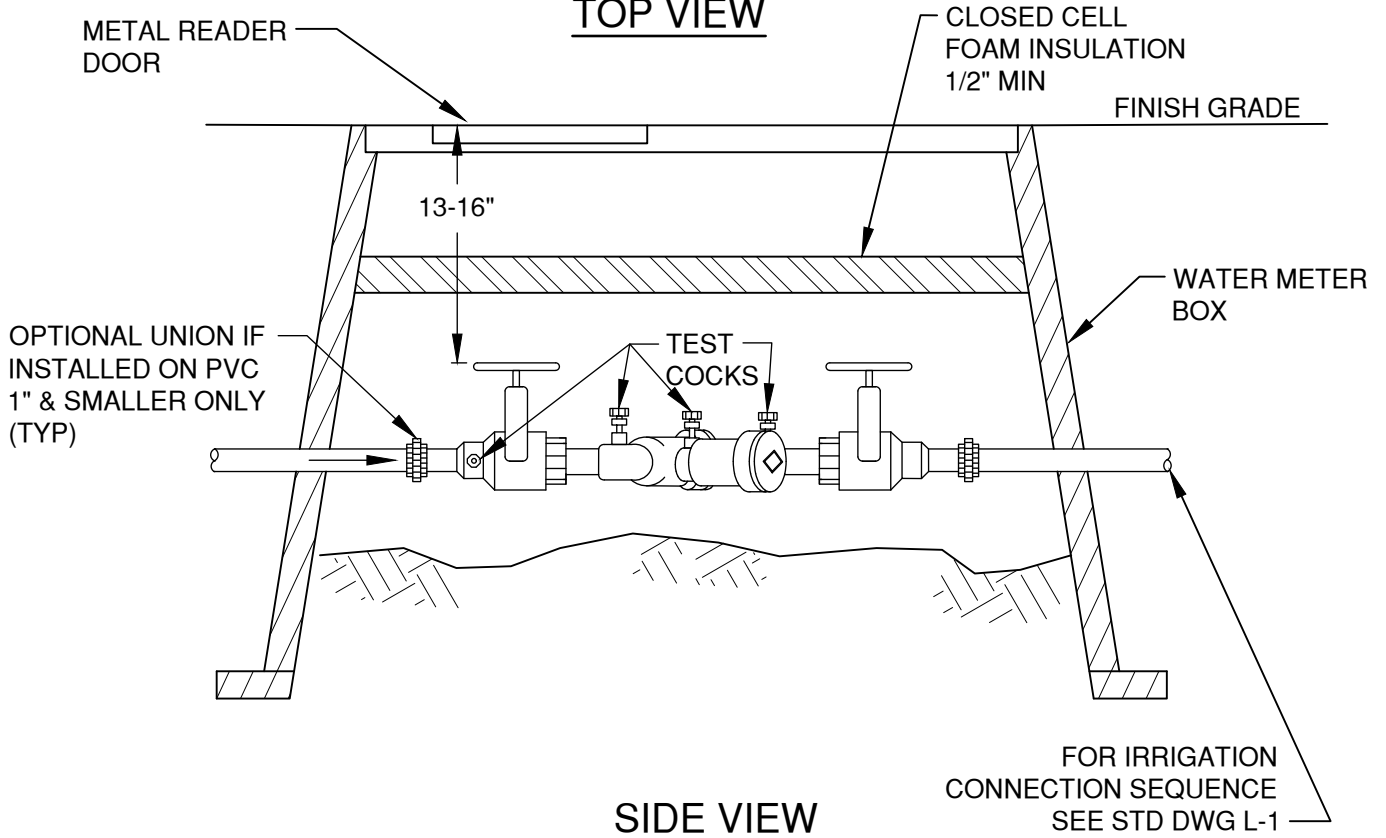

**SIDE VIEW**

**NOTES:**

1. DOUBLE CHECK VALVE ASSEMBLIES (DCVAs) MAY BE INSTALLED VERTICAL AS WELL AS HORIZONTAL PROVIDED THAT THE ASSEMBLY IS APPROVED FOR VERTICAL INSTALLATIONS
2. DCVAs MAY BE INSTALLED BELOW GRADE IN A VAULT PROVIDED WATER TIGHT, THREADED PLUGS ARE INSTALLED IN THE TEST COCKS, BUT THE ASSEMBLY SHALL NOT BE SUBJECT TO CONTINUOUS IMMERSION
3. BLOWOUT PORTS, WHEN REQUIRED MUST BE INSTALLED DOWNSTREAM OF LAST ASSEMBLY SHUTOFF

DRAWN	AJD
DIV	WATER
REV	DATE



**CITY OF BEND**  
STANDARD DRAWING  
710 NW WALL ST., BEND, OREGON 97701

**TYPICAL DCVA INSTALLATIONS 2" AND SMALLER**

SCALE	NTS
DATE	04/16/2026
APPR	
STD DWG	W-13

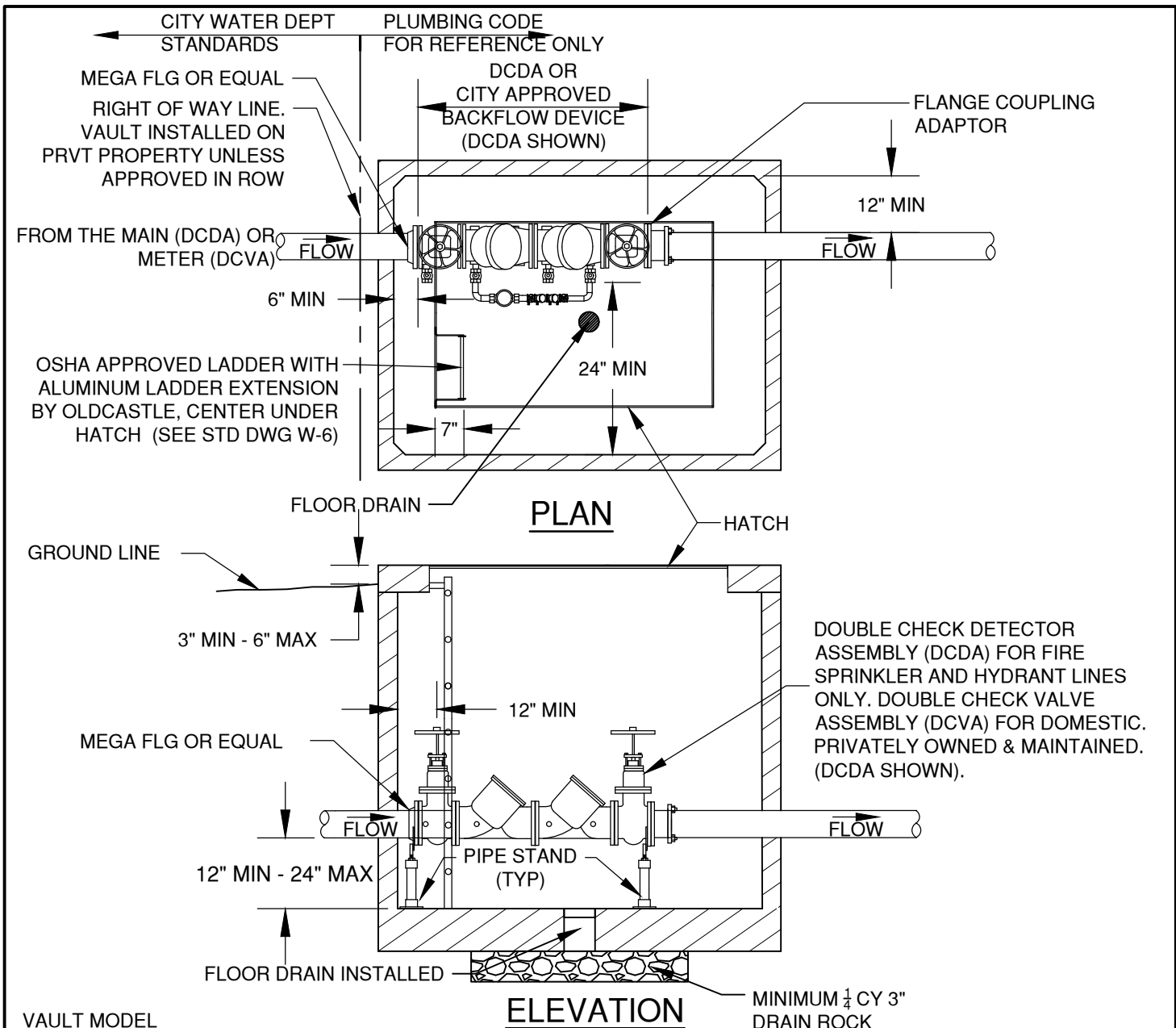

**VAULT MODEL**

PIPE SIZE	UTILITY VAULT OR EQUAL		BILCO DOOR OR EQUAL
	W/ FDC*	W/O FDC	
3		660-WA	J-5AL
4	676-WA	577-WA	J-5AL
6	687-WA	676-WA	J-5AL
8	5106-LA	687-WA	JD-3AL
10	5106-LA	5106-LA	JD-3AL

\* FOR FIRE SPRINKLER VAULTS, REFER TO W-13B. FIRE SPRINKLER VAULTS INSTALLED IN RIGHT OF WAY OR UTILITY EASEMENT ONLY WHEN APPROVED BY CITY ENGINEER.

**NOTES:**

- ENGINEER TO PROVIDE RESTRAIN DETAIL FOR ALL PIPE ENTERING & EXITING VAULT
- CONTRACTOR TO SEAL ALL OPENINGS IN VAULT WITH NON-SHRINK GROUT PRIOR TO BACKFILLING
- CONDUIT BROUGHT TO VAULT FOR PUMP POWER AND DETECTOR WIRING.
- ENGINEERED DESIGN TO BE PROVIDED WITH PERMIT.
- VAULT AND LID TO BE TRAFFIC RATED
- ALL FIRE LINES SHALL HAVE THE VAULT & DOUBLE CHECK DETECTOR ASSEMBLY (DCDA) INSTALLED CONCURRENTLY FOR TESTING & DISINFECTION TO THE CITY MAIN.
- PIPE SHALL MEET CITY ROW SPECIFICATIONS FROM MAIN TO DCDA

DRAWN	AJD
DIV	WATER
REV	DATE



**CITY OF BEND**

**CITY OF BEND**

STANDARD DRAWING

710 NW WALL ST., BEND, OREGON 97701

**2" & LARGER DOUBLE CHECK VALVE ASSEMBLY**

SCALE NTS

DATE 01/31/2022

APPR

STD DWG W-13A

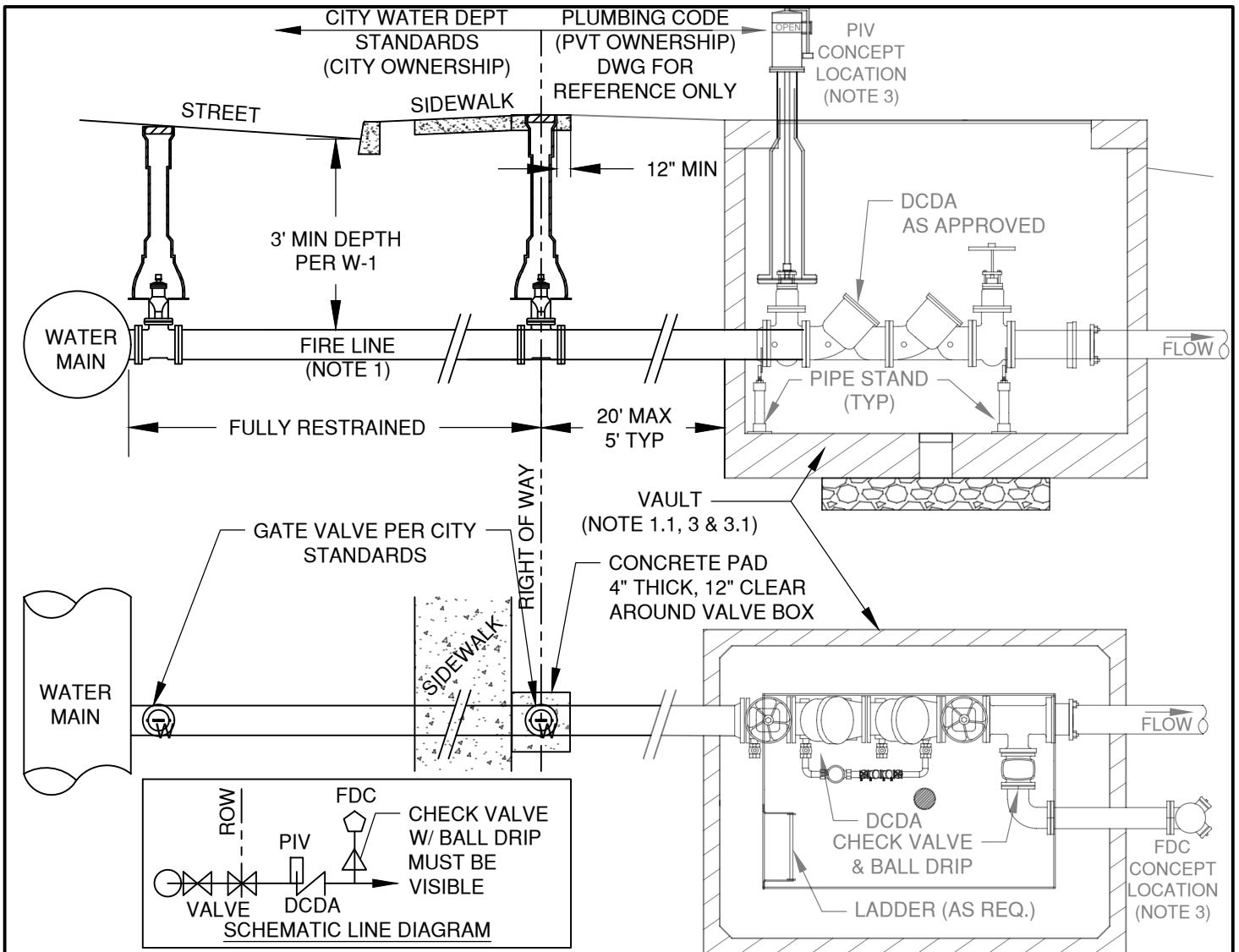

**NOTES:**

1. FIRE VAULT AND DCDA IS SHOWN FOR REFERENCE ONLY. VAULT AND PLUMBING BEYOND THE GATE VALVE SHALL BE INSTALLED PER PLUMBING CODE AND INSPECTED BY THE BUILDING DEPARTMENT.
  - 1.1. WHERE FIRE VAULT IS APPROVED BY CITY ENGINEER TO BE WITHIN THE ROW OR PUBLIC EASEMENT, VAULT SIZES ON STD DWG W-13A SHALL APPLY AND "FOR REFERENCE NOTES" ON THIS SHEET WOULD APPLY.
2. FIRE LINE TO BE 4" MIN DUCTILE IRON WATER MAIN PER CITY OF BEND SPECIFICATIONS. FIRE LINE TO BE SIZED BY ENGINEER UNDER A RIGHT OF WAY PERMIT.
3. VAULT TO BE SIZED BY ENGINEER IN CONFORMANCE TO BUILDING/FIRE/PLUMBING CODE, MEETING THE DOUBLE CHECK DETECTOR ASSEMBLY (DCDA) MANUFACTURER'S INSTALLATION SPECIFICATIONS. DESIGN SHALL ACCOUNT FOR ANY FREEZE PROTECTION REQUIRED TO MEET FIRE CODE.
  - 3.1. WHERE BUILDING IS WITHIN 20 FEET OF THE RIGHT OF WAY LINE, THE DCDA CAN BE WITHIN THE BUILDING'S MECHANICAL ROOM AS APPROVED BY THE CITY ENGINEER. THE DCDA MUST BE LOCATED FRONTING THE ROW AND LOCATED AT THE BUILDING PENETRATION. THE FDC MUST BE VISIBLE FROM ROW. ACCESS TO THE MECHANICAL ROOM TO BE PROVIDED BY AN EXTERIOR DOOR WITH KNOX BOX UNLESS OTHERWISE APPROVED.
  - 3.2. VAULTS ARE TO BE PLACED OUT OF HARD SURFACES (SIDEWALKS, DRIVEWAYS/ROADWAYS, ECT.)
4. POST INDICATOR VALVE (PIV) AND FIRE DEPARTMENT CONNECTION (FDC) TO BE LOCATED IN CLEAR VIEW OF THE FRONTAGE STREET, WITH THE FDC LOCATED WITHIN AN ALLOWABLE DISTANCE FROM A HYDRANT. PIV AND FDC MAY BE MOUNTED ON THE BUILDING IN CONFORMANCE WITH THE FIRE CODE AND AS APPROVED. PIV AND FDC CAN BE MOUNTED OUTSIDE THE VAULT OR THROUGH THE VAULT LID PROVIDED THEY DON'T INTERFERE WITH VAULT ACCESS AND THE PENETRATIONS ARE GROUTED AND DON'T NEGATE THE STRUCTURAL INTEGRITY OF THE VAULT. PIV NOT TO BE USED IN-LIEU OF ISOLATION GATE VALVE AT PROPERTY LINE.
5. ALL ELECTRICAL TO VAULT AND PIV TO BE INSTALLED PER BUILDING AND FIRE CODE AS REQUIRED.
6. PIPE SHALL MEET CITY ROW SPECIFICATIONS FROM MAIN TO DCDA.

DRAWN <b>AJD</b> DIV <b>WATER</b> REV DATE	 <b>CITY OF BEND</b>	<b>CITY OF BEND</b> STANDARD DRAWING 710 NW WALL ST., BEND, OREGON 97701	SCALE <b>NTS</b> DATE <b>03/22/2023</b> APPR STD DWG <b>W-13B</b>
<b>FIRE SPRINKLER LINE</b>			

# DRAWING IS FOR REFERENCE ONLY

WHERE THE STRUCTURE IS PROPOSED  
OUTSIDE THE RIGHT OF WAY OR  
UTILITY EASEMENT

INSTALL TO PLUMBING CODE      INSTALL TO CITY STANDARDS

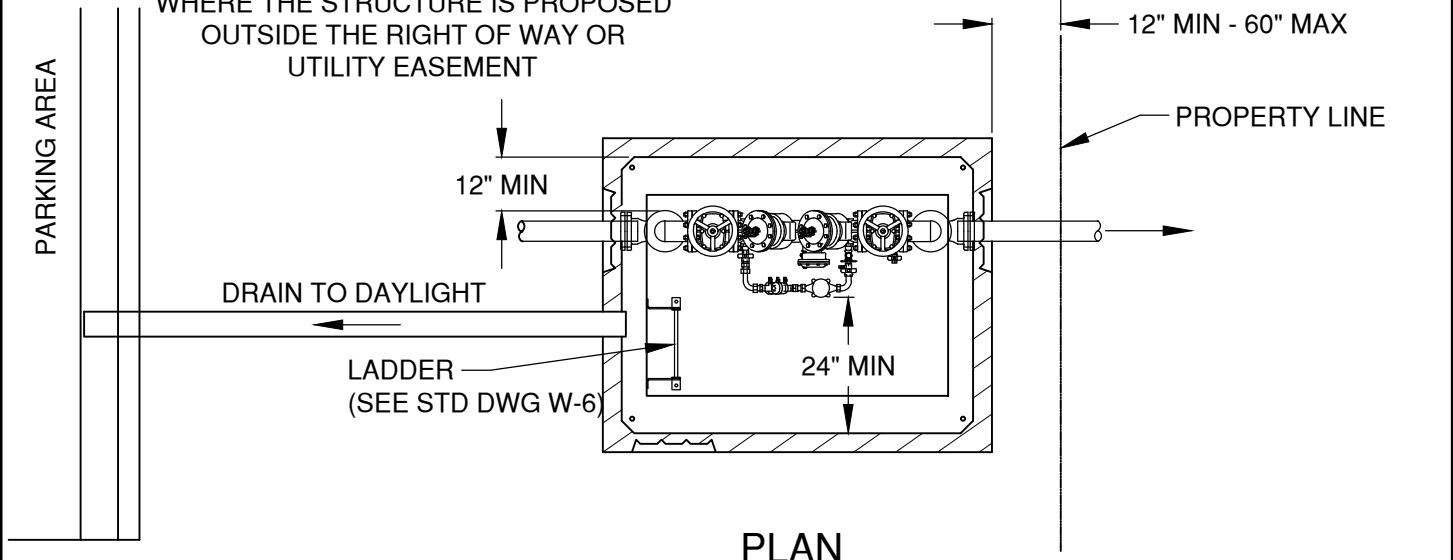

**PLAN**

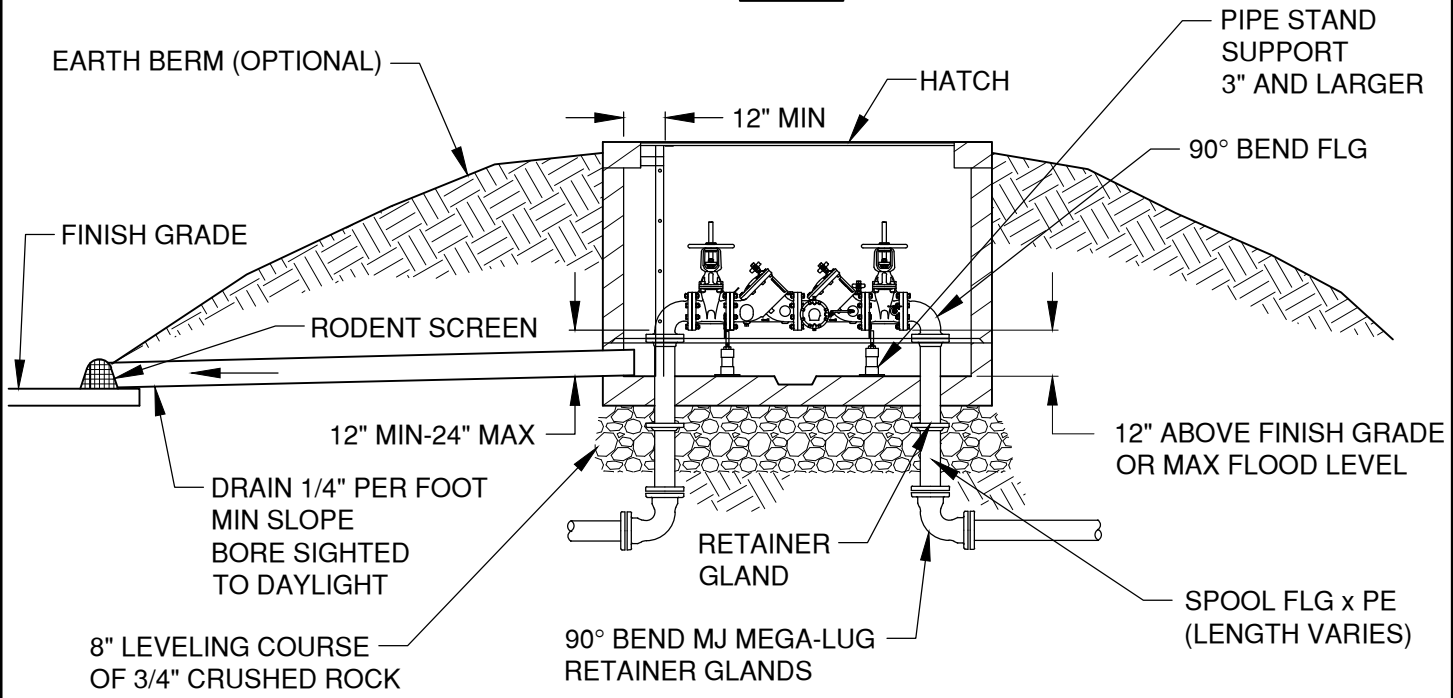

**PROFILE**

- NOTES:
1. THIS DRAWING IS FOR REFERENCE ONLY. INSTALL PER PLUMBING CODE AND BUILDING DEPARTMENT REQUIREMENTS.
  2. ENGINEER TO PROVIDE RESTRAINT DETAIL FOR ALL PIPE ENTERING & EXITING VAULT
  3. CONTRACTOR TO SEAL ALL OPENINGS IN VAULT WITH NON-SHRINK GROUT PRIOR TO BACKFILLING
  4. HIGH OR LOW HAZARD CONNECTIONS SHALL BE IDENTIFIED AND VERIFIED WITH CITY CROSS CONNECTION SPECIALIST
  5. PIPE SHALL MEET CITY ROW SPECIFICATIONS FROM MAIN TO DCDA

DRAWN	AJD
DIV	WATER
REV	DATE



**CITY OF BEND**  
STANDARD DRAWING  
710 NW WALL ST., BEND, OREGON 97701

**2 1/2"-10" REDUCED PRESSURE BACKFLOW ASSEMBLY**

SCALE	NTS
DATE	01/31/2022
APPR	
STD DWG	W-15

# DRAWING IS FOR REFERENCE ONLY

WHERE THE STRUCTURE IS PROPOSED  
OUTSIDE THE RIGHT OF WAY OR  
UTILITY EASEMENT

## VAULT SPECIFICATIONS

WATER LINE DIAMETER	MODEL
1"	OLDCASTLE 3030-LA (OR EQUAL)
1-1/2" - 2"	OLDCASTLE 3642-PUT (OR EQUAL)

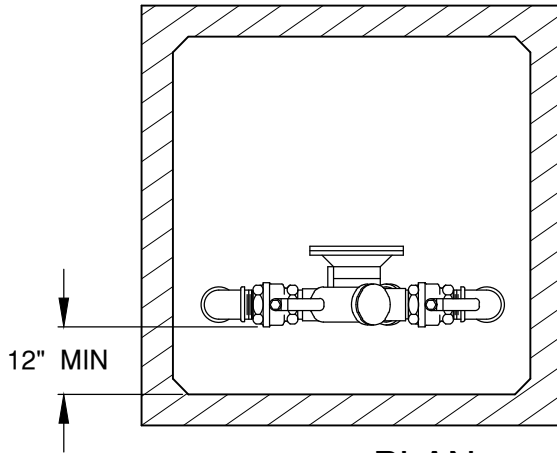

**PLAN**

OREGON STATE APPROVED  
PRESSURE BACKFLOW  
PREVENTER

HATCH

SLOPE EARTH AWAY FROM  
VAULT IN BERM AREA

12" MIN ABOVE  
FINISH GRADE

UNION (TYP)

RODENT  
SCREEN

FINISH GRADE

DRAIN TO DAYLIGHT

CONCRETE PAD  
ON 6" OF BASE ROCK

**ELEVATION**

**NOTES:**

1. THIS DRAWING IS FOR REFERENCE ONLY. INSTALL PER PLUMBING CODE AND BUILDING DEPARTMENT REQUIREMENTS.
2. REDUCED PRESSURE BACKFLOW ASSEMBLY TO BE LOCATED DIRECTLY DOWN STREAM OF WATER METER
3. BRASS, STAINLESS, OR PLASTIC PLUGS TO BE INSTALLED IN TEST COCKS IF BELOW GROUND INSTALLATION
4. HIGH OR LOW HAZARD CONNECTIONS SHALL BE IDENTIFIED AND VERIFIED WITH CITY CROSS CONNECTION SPECIALIST

DRAWN	AJD
DIV	WATER
REV	DATE



**CITY OF BEND**

## CITY OF BEND

STANDARD DRAWING

710 NW WALL ST., BEND, OREGON 97701

**1"-2" REDUCED PRESSURE BACKFLOW ASSEMBLY**

SCALE NTS

DATE 01/31/2022

APPR

STD DWG W-15A

# DRAWING IS FOR REFERENCE ONLY

WHERE THE STRUCTURE IS PROPOSED  
OUTSIDE THE RIGHT OF WAY OR  
UTILITY EASEMENT

(SEE NOTE 3)

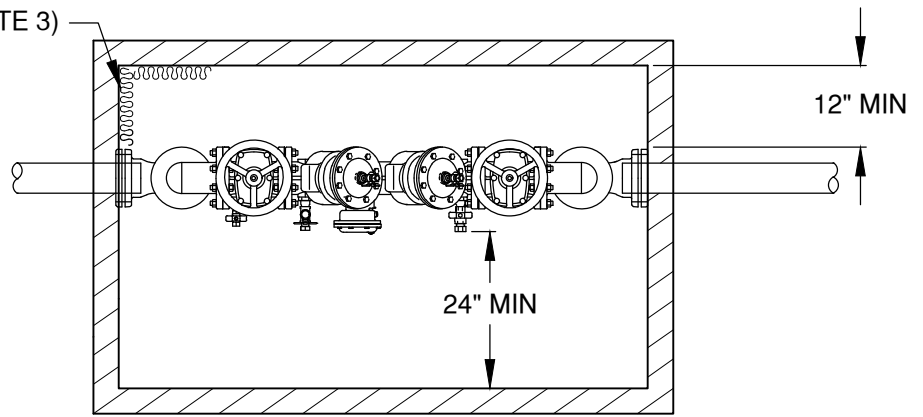

**PLAN**

1060 ASSE  
CLASS 1;  
WATTS BOX,  
SAFE-T-COVER,  
HOT BOX, OR  
EQUAL

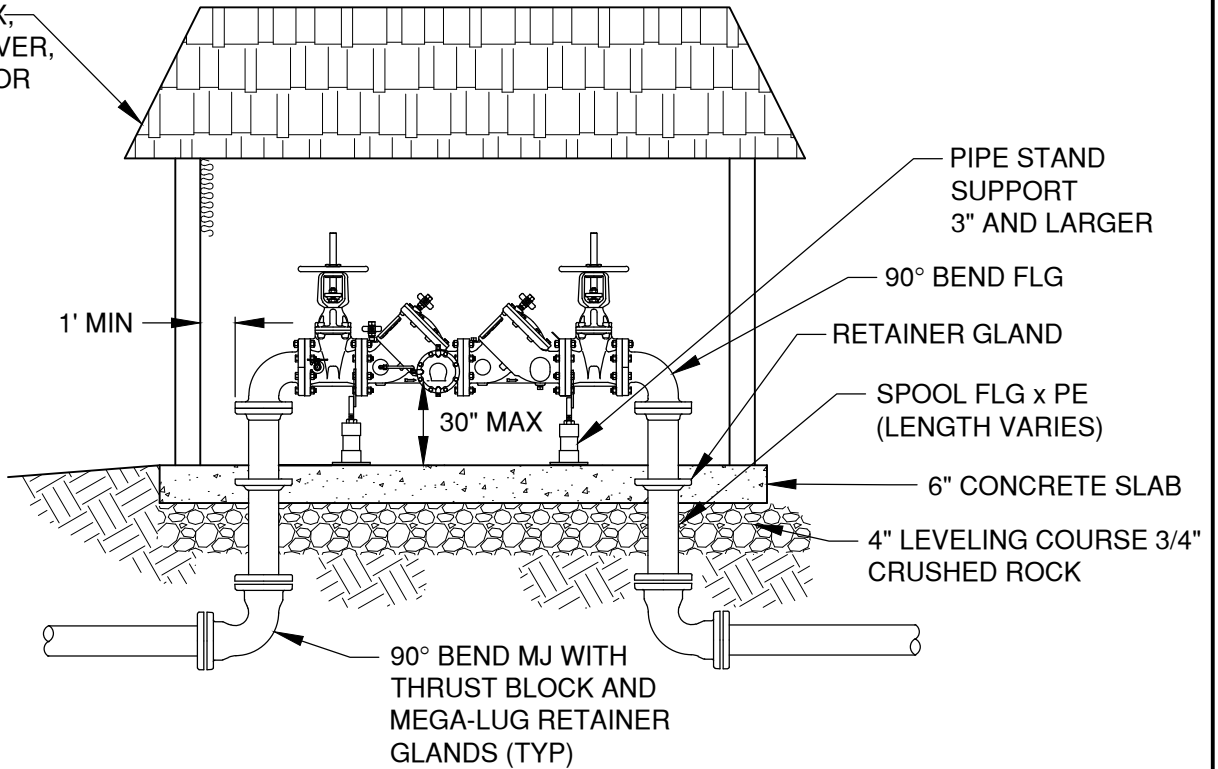

**PROFILE**

**NOTES:**

1. THIS DRAWING IS FOR REFERENCE ONLY. INSTALL PER PLUMBING CODE AND BUILDING DEPARTMENT REQUIREMENTS OR AS BY MANUFACTURER'S REQUIREMENTS.
2. REDUCED PRESSURE BACKFLOW ASSEMBLY SHALL BE INSTALLED HORIZONTALLY UNLESS APPROVED FOR OTHER ORIENTATION
3. ALL CLEARANCES APPLY TO OUTSIDE, IN-BUILDING, AND VAULT INSTALLATIONS
4. STRUCTURE TO BE INSULATED AND HAVE A HEAT SOURCE TO KEEP ENCLOSURE AT 40°F (NFPA 13-4-5.4.1.1)
5. ENCLOSURE SHALL INCLUDE A BORE SIGHTED DRAIN TO DAYLIGHT CAPABLE OF DRAINING A FULL RELIEF VALVE DISCHARGE. MAKE/MODEL/SIZE WILL DICTATE THE SIZE OF THE ENCLOSURE.
6. ALL ASSEMBLIES 2 1/2" AND LARGER SHALL BE FLANGED
7. HIGH OR LOW HAZARD CONNECTIONS SHALL BE IDENTIFIED AND VERIFIED WITH CITY CROSS CONNECTION SPECIALIST

DRAWN	AJD
DIV	WATER
REV	DATE



**CITY OF BEND**

**CITY OF BEND**  
STANDARD DRAWING

710 NW WALL ST., BEND, OREGON 97701

**2 1/2" + REDUCED PRESSURE BACKFLOW ASSEMBLY**

SCALE	NTS
DATE	01/31/2022
APPR	
STD DWG	W-15B

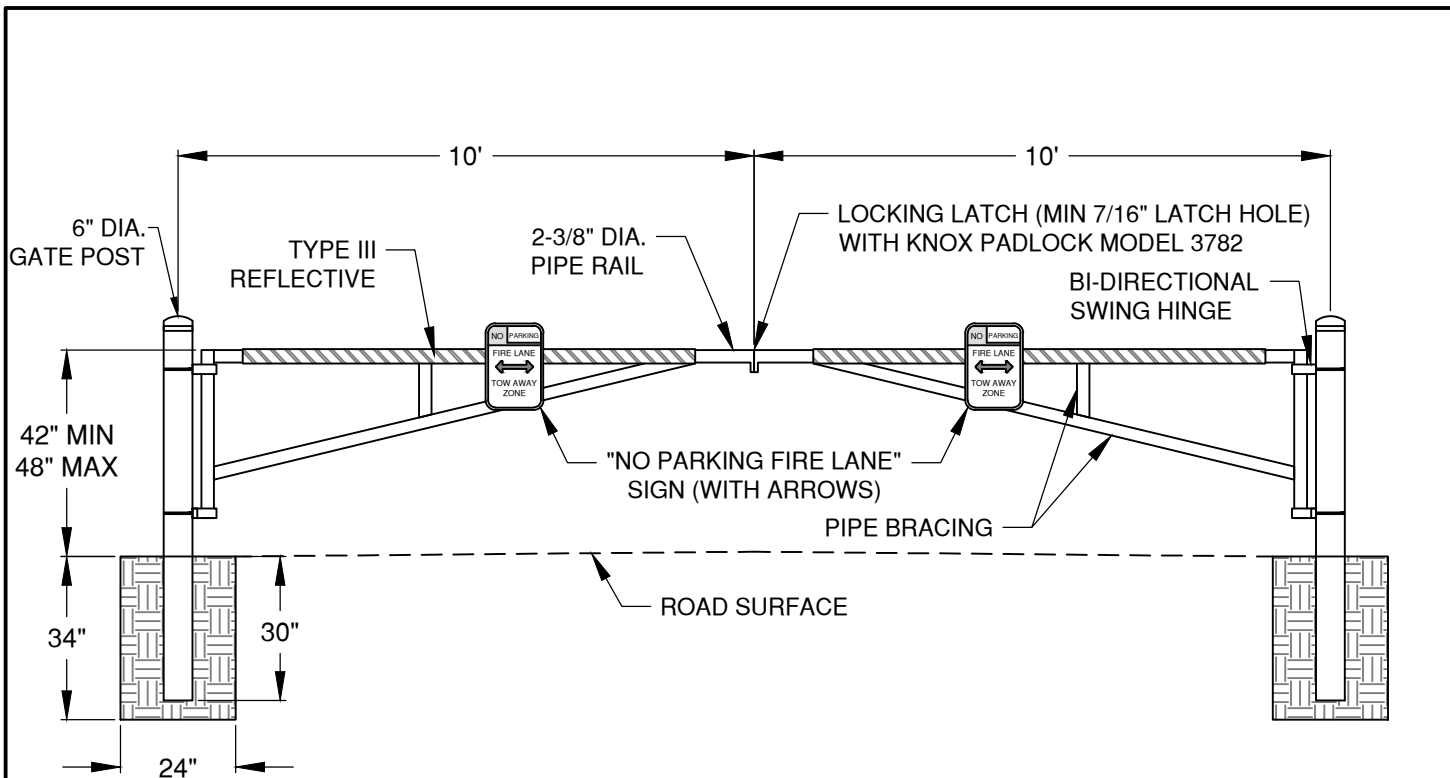

**NOTES:**

1. ALL MATERIAL SHALL BE SCHEDULE 40, GALVANIZED STEEL PIPE.
2. PROTECTIVE FINISH SHALL BE HOT-DIPPED, GALVANIZED GRAY.
3. CONTRACTOR TO INSTALL NO PARKING, FIRE LANE SIGN ON EACH SIDE OF GATE MEETING THE REQUIREMENTS OF OFC D103.6.
4. CONTRACTOR TO INSTALL TYPE III REFLECTIVE STRIPING ON BOTH SIDES OF GATE. STRIPING SHALL BE ALTERNATING RED/WHITE STRIPES, 6" WIDE AT 45 DEGREE ANGLE.
5. CONCRETE SHALL BE COMMERCIAL GRADE CONCRETE PER SPECIFICATION SECTION 00440.
6. GATE POSTS SHALL BE LOCATED OUTSIDE OF THE ROADWAY. IF PAVEMENT AND CURBS ARE PRESENT, GATE POSTS SHALL BE LOCATED BEHIND CURB.
7. COORDINATE INSTALLATION OF KNOX PADLOCK WITH CITY OF BEND FIRE DEPARTMENT.

DRAWN AJD	 <b>CITY OF BEND</b>	<b>CITY OF BEND</b> STANDARD DRAWING 710 NW WALL ST., BEND, OREGON 97701	SCALE NTS
DIV WATER			DATE 01/31/2022
REV DATE			APPR
		<b>FIRE GATE</b>	STD DWG W-21

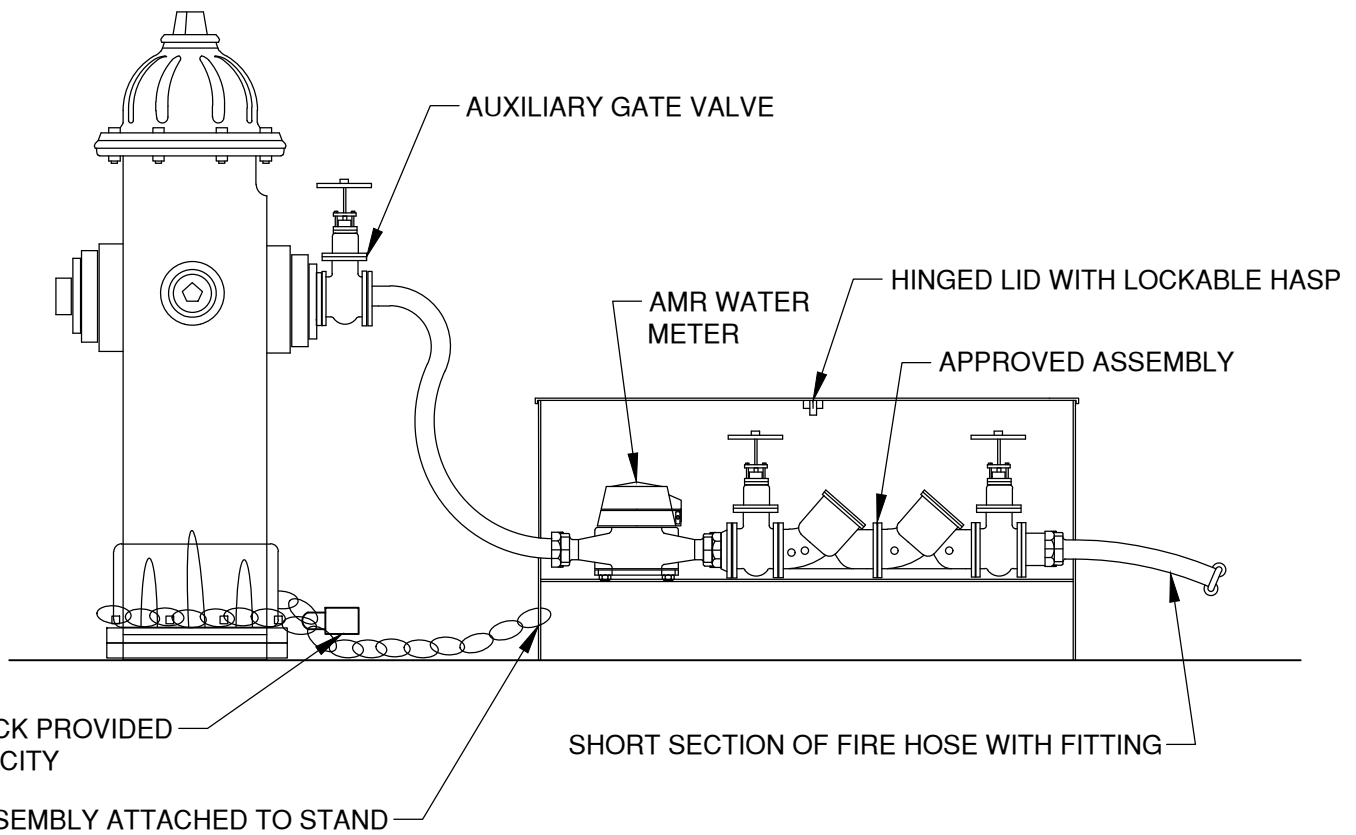

**NOTES:**

1. GATE VALVE, METER, REDUCED PRESSURE BACKFLOW ASSEMBLY & DOUBLE CHECK VALVE ASSEMBLY, & BOX WILL BE SUPPLIED & SET UP BY THE CITY WATER DEPT @ THE CONTRACTORS REQUEST AFTER OBTAINING A CITY HYDRANT PERMIT
2. HYDRANT PERMIT HOLDER TO PROTECT THE ENTIRE UNIT FROM FREEZING
3. BACKFLOW ASSEMBLY MUST BE TESTED IF UNIT IS MOVED TO ANOTHER LOCATION.

DRAWN AJD	
DIV WATER	
REV	DATE



**CITY OF BEND**

**CITY OF BEND**

STANDARD DRAWING

710 NW WALL ST., BEND, OREGON 97701

**HYDRANT PERMIT/FILLING TANKER TRUCK**

SCALE NTS

DATE 01/31/2022

APPR

STD DWG W-22

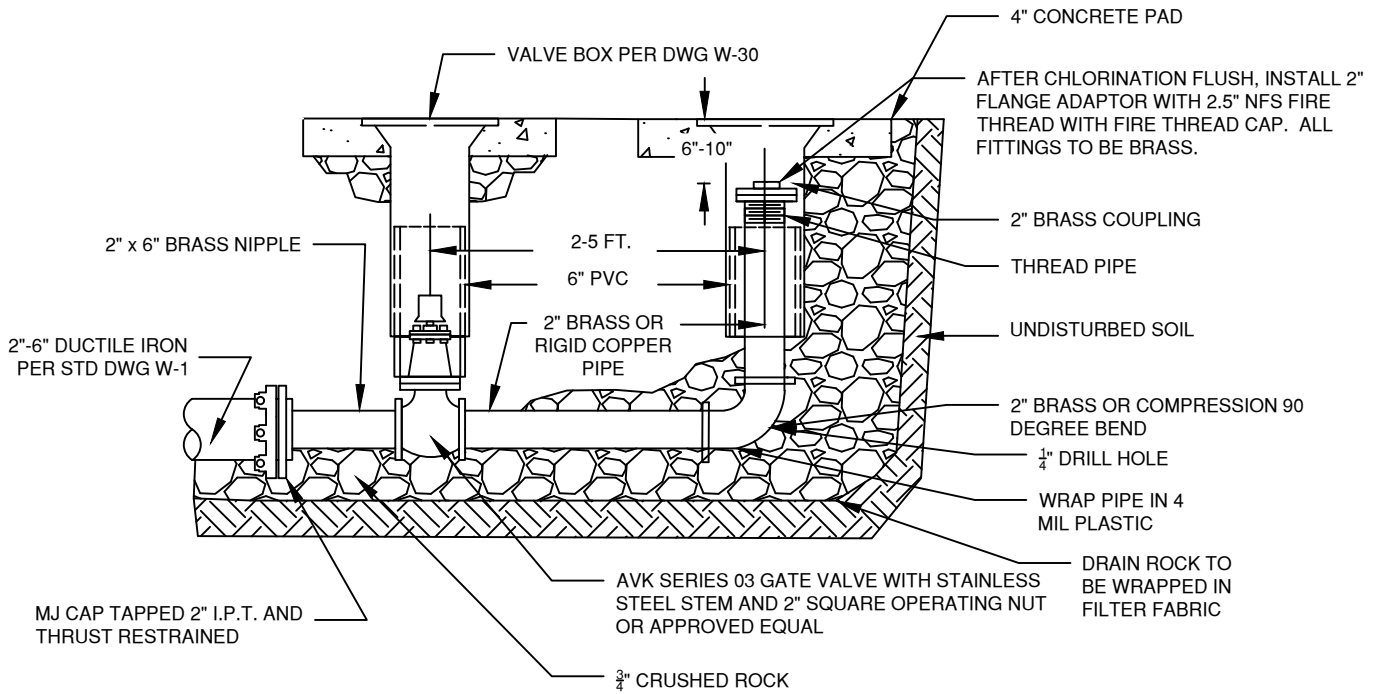

**NOTES:**

1. USE CITY STANDARD VALVE BOXES, LIDS, AND 6" PVC EXTENSION.
2. BLOW-OFF UNIT SHALL BE BACKFILLED WITH 3/4" MINUS CRUSHED ROCK. ALL COMPACTION TO COMPLY WITH SPECIFICATION SECTION 00330.43 AND 00405.46(C).
3. TEMPORARY BLOW-OFF IS ONE REMOVED AT THE END OF WATER LINE TESTING AND INSTALLATION AND PRIOR TO PROJECT PAVING. A PERMANENT BLOW-OFF REMAINS ON THE PROJECT AFTER ACCEPTANCE.
4. PLACE BLOW-OFF STANDPIPE 3' INSIDE ROW LINE AT THE END OF STREET (2' FROM BARRICADE).
5. USE CITY STANDARD VALVE BOX, LID, AND 6" PVC EXTENSION FOR BLOW-OFF VALVE.
6. BLOW OFF RISER TO BE ONE CONTINUOUS PIECE.
7. USE EBAA IRON "MEGALUG" OR APPROVED EQUAL RETAINER GLAND ON MJ CAP. RESTRAIN PER ENGINEER.
8. 2" PVC PLUG WITH SQUARE NUT TO BE HAND TIGHTENED ONLY.

DRAWN <b>AJD</b> DIV <b>WATER</b> REV    DATE	 <b>CITY OF BEND</b>	<b>CITY OF BEND</b> STANDARD DRAWING 710 NW WALL ST., BEND, OREGON 97701	SCALE <b>NTS</b> DATE <b>01/31/2022</b> APPR STD DWG <b>W-23</b>
<b>STANDARD 2" BLOW-OFF ASSEMBLY</b>			



ECLIPSE NO. 88 SAMPLING STATION WITH THREADED  
 OUTLET NOZZLE AND BRASS INTERIOR, STAND PIPE  
 GALVANIZED EXTERIOR OR APPROVED EQUAL

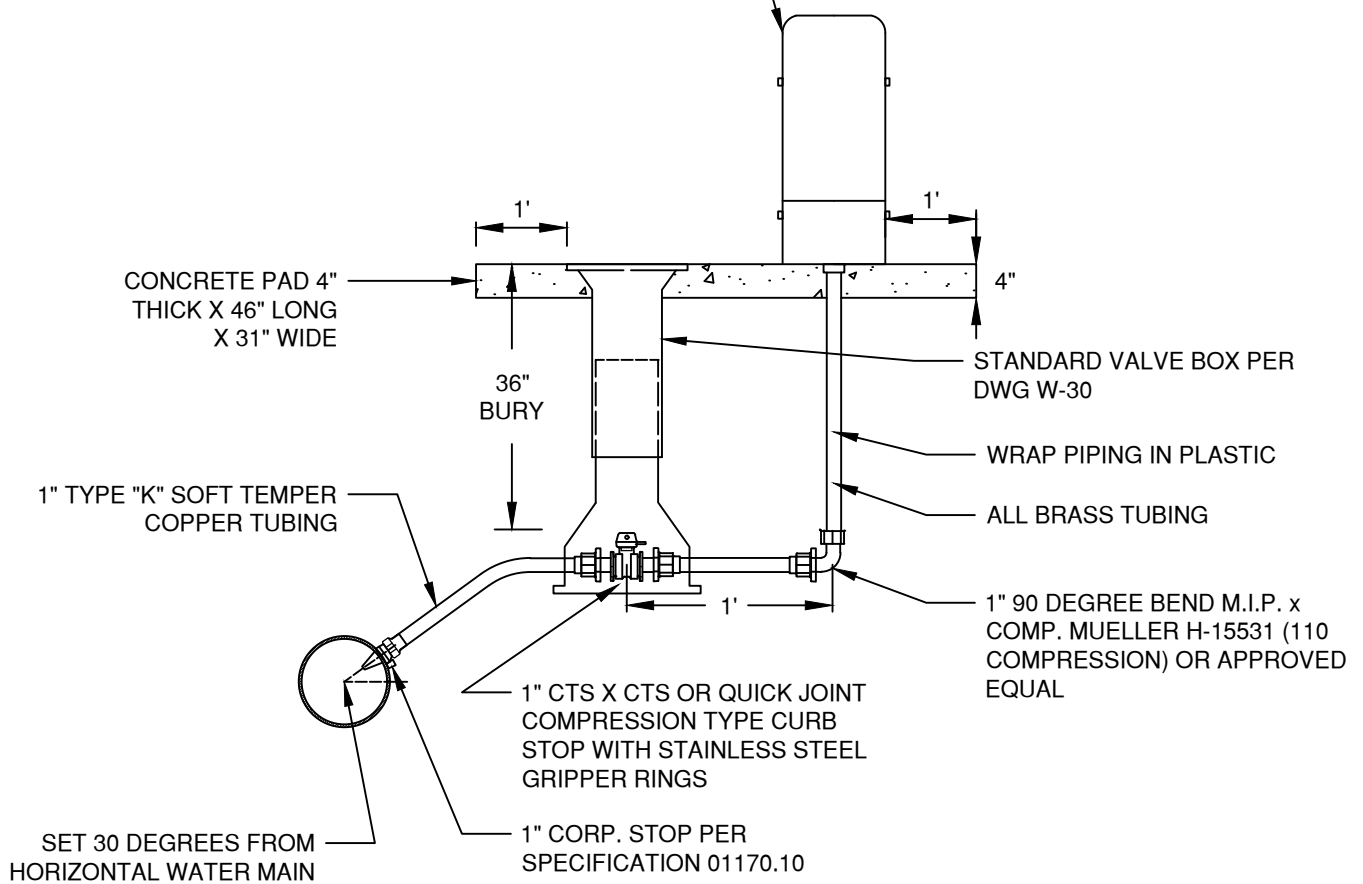

NOTES:

1. ALL PIPE AND STRUCTURES SHALL BE BACKFILLED WITH SCREENED MAX  $\frac{3}{4}$ " MINUS CRUSHED ROCK. ALL COMPACTION TO COMPLY WITH SPECIFICATION SECTION 00330.43 AND 00405.46(C).
2. SET STATION AT LOT LINE UNLESS OTHERWISE SPECIFIED.
3. WHEN CROSSING, CATHODICALLY PROTECTED SYSTEM, INSTALL COPPER IN PVC SLEEVE FOR 5' EACH SIDE OF THE CROSSING.
4. WHERE NO SIDEWALK EXISTS, PLACE CONC. PAD AS SHOWN. WHERE SIDEWALKS EXIST, PLACE MIN. 12" AROUND BACK OF SAMPLE STA. AND INCORPORATE INTO NEW SIDEWALK POUR.

DRAWN	AJD
DIV	WATER
REV	DATE



CITY OF BEND

CITY OF BEND

STANDARD DRAWING

710 NW WALL ST., BEND, OREGON 97701

STANDARD WATER SAMPLING STATION

SCALE NTS

DATE 11/01/2024

APPR

STD DWG W-25

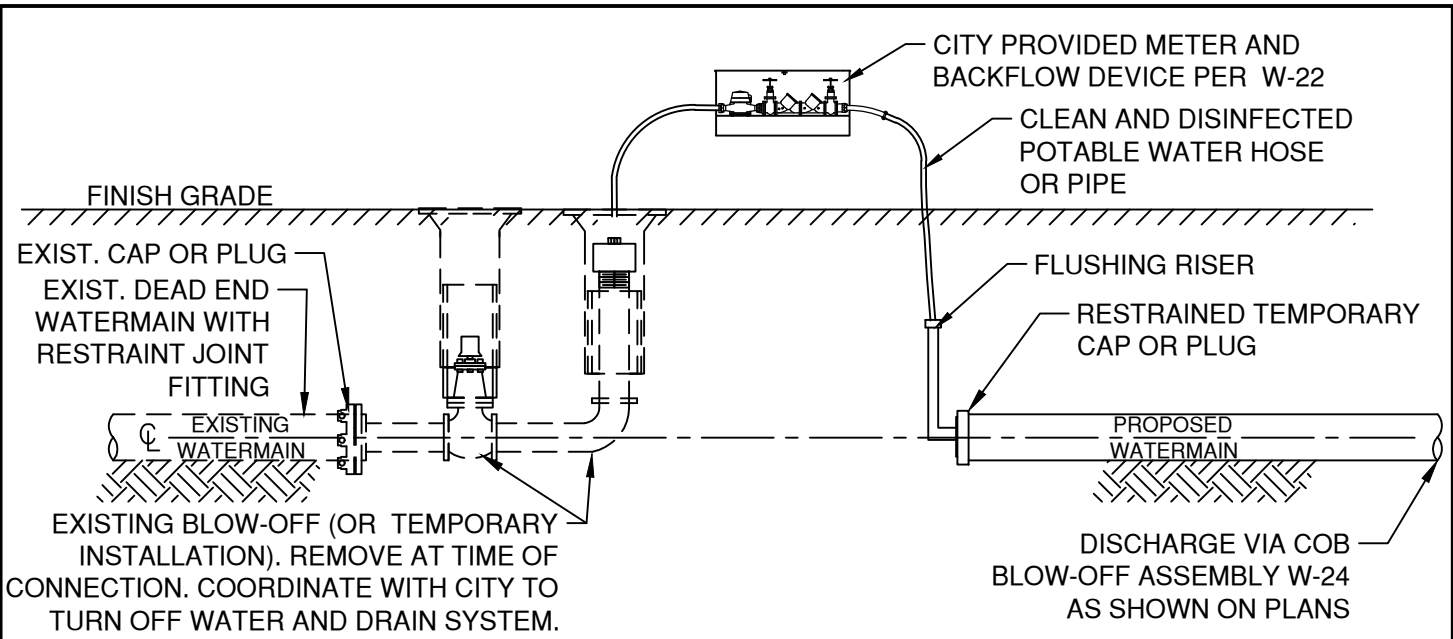

**OPTION 1: TESTING AND FLUSHING USING A BLOW OFF ASSEMBLY**

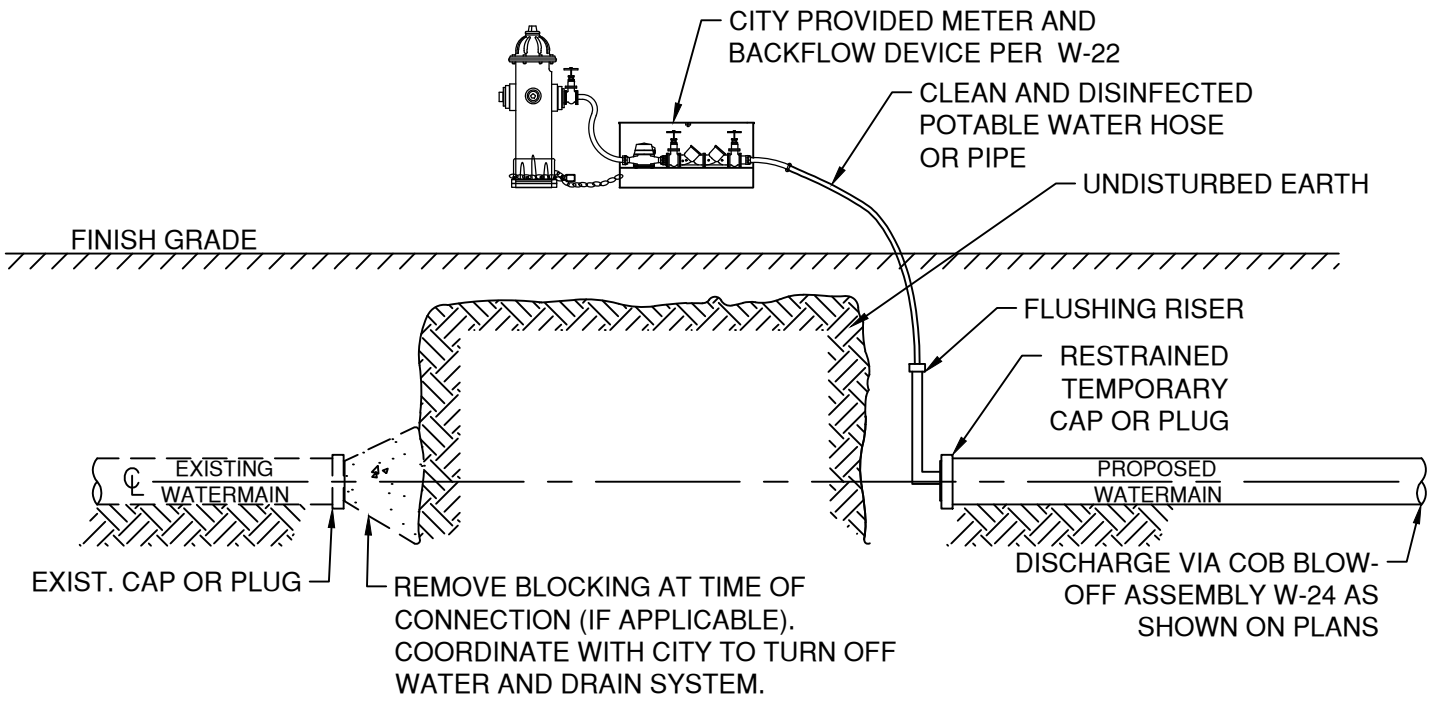

**OPTION 2: TESTING AND FLUSHING USING NEARBY HYDRANT**

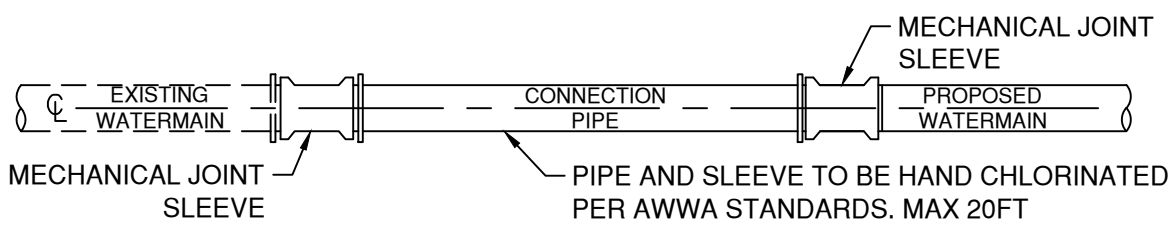

**CONNECTION AFTER TESTING, FLUSHING AND APPROVAL**

DRAWN AJD	
DIV WATER	
REV	DATE



**CITY OF BEND**  
 STANDARD DRAWING  
 710 NW WALL ST., BEND, OREGON 97701

SCALE NTS
DATE 01/31/2022
APPR
STD DWG W-29

**CROSS CONNECTION DETAIL**

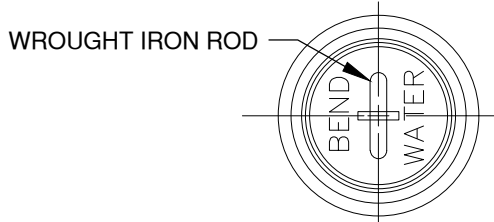

**COVER PLAN**

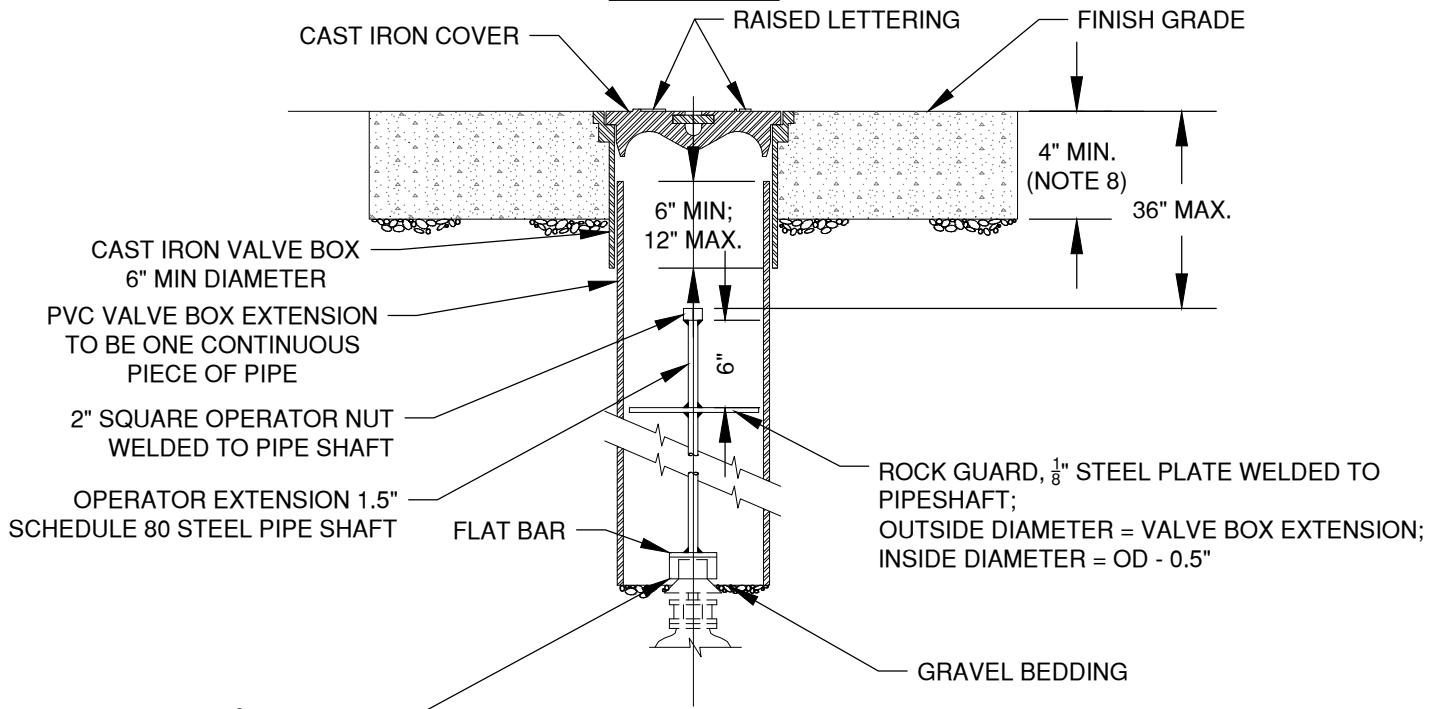

**VALVE BOX EXTENSION SECTION**

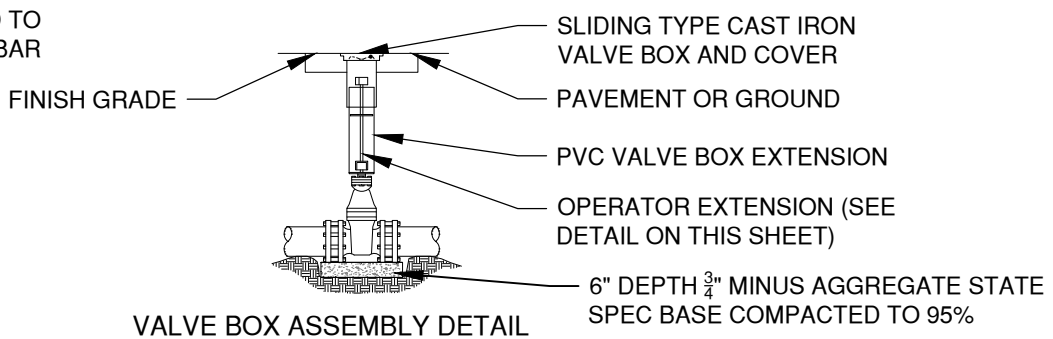

**VALVE BOX ASSEMBLY DETAIL**

**NOTES:**

1. VALVE BOX NOT TO REST ON OPERATING ASSEMBLY.
2. OPERATOR EXTENSION REQUIRED WHEN VALVE NUT IS DEEPER THAN 6" FROM FINISH GRADE.
3. CENTER VALVE BOX ON AXIS OF OPERATOR NUT.
4. VALVES TO BE INSTALLED WITH COMPACTED AGGR. BASE ON UNDISTURBED GROUND.
5. WELDS SHALL BE MINIMUM 0.5" ALL AROUND.
6. HOT DIP GALVANIZE OPERATOR EXTENSION AFTER FABRICATION.
7. CASTING SHALL MEET H20 LOAD REQUIREMENT.
8. PROVED 24"x24"x4" CONCRETE PAD WITH EXPANSION JOINT AROUND VALVE BOX WHEN INSTALLED OUTSIDE OF ROADWAY.
9. SEE PROJECT PLANS FOR DETAILS NOT SHOWN.
10. ALL VALVE BOXES SHALL BE PLACED OUTSIDE THE PATH OF TRAVEL ON SIDEWALK AND DRIVEWAY APRONS.

DRAWN AJD	
DIV WATER	
REV	DATE



**CITY OF BEND**  
STANDARD DRAWING  
710 NW WALL ST., BEND, OREGON 97701

**VALVE BOX AND OPERATOR EXTENSION ASSEMBLY**

SCALE NTS
DATE 11/01/2024
APPR
STD DWG W-30