CITY OF BEND STANDARD DRAWINGS

Roadway (R)

GENERAL NOTES FOR STD DWGS R-1A THROUGH R-1H:

1. CENTER STREETS IN THE RIGHT-OF-WAY UNLESS OTHERWISE APPROVED BY CITY ENGINEER FOR UNIQUE TRANSITIONS OR SITE CONSTRAINTS.
2. THE LEVEL OF TRAFFIC STRESS PER THE ODOT APM CH. 14 IS SHOWN ON EACH STANDARD CROSS-SECTION. MODIFICATION OF THE CROSS-SECTIONS MUST PROVIDE THE APPROPRIATE LTS.
3. INSTALL SIDEWALKS/SHARED-USE PATHS PROPERTY TIGHT. SIDEWALKS/SHARED-USE PATHS MAY MEANDER AROUND UTILITIES, TREES, AND OTHER NON-MOVEABLE OBJECTS. METERS, MANHOLES, AND VALVES ARE NOT PERMITTED WITHIN THE SIDEWALK UNLESS OTHERWISE APPROVED BY THE CITY ENGINEER. EXCEPTIONS WILL ONLY BE PERMITTED IF SIDEWALK CANNOT MEANDER AROUND THE EXISTING CONSTRAINT, OR THE OBSTACLE CANNOT BE REMOVED/RELOCATED. EASEMENTS ARE REQUIRED WHERE SIDEWALK/SHARED-USE PATH MEANDERS OUT OF THE RIGHT-OF-WAY.
4. PAVEMENT SECTIONS FOR STREETS AND SIDEWALKS PER THE THICKNESSES NOTED IN TABLE BELOW OR AS SPECIFIED IN A STAMPED GEOTECHNICAL REPORT APPROVED BY THE CITY ENGINEER.
5. RETAINING WALLS AND STAIRS ARE NOT PERMITTED WITHIN THE RIGHT-OF-WAY UNLESS OTHERWISE APPROVED BY THE CITY ENGINEER.
6. STREET CROSS-SECTION/IMPROVEMENT STANDARDS ARE BASED ON STREET CLASSIFICATION. REFERENCE THE BEND DEVELOPMENT CODE SECTION 3.4 PUBLIC IMPROVEMENTS STANDARDS AND STANDARD CROSS-SECTIONS FOR ADDITIONAL DETAIL.
7. THE CROSS-SLOPE OF THE PLANTER STRIP BETWEEN THE CURB AND RIGHT-OF-WAY SHALL NOT BE STEEPER THAN 4H:1V TO PROVIDE A RECOVERABLE ROADSIDE SLOPE. 50H:1V (2%) IS TYPICAL/PREFERRED.
8. MAX 1.5H:1V CUT SLOPES PERMITTED IN ROCK CUTS WHEN APPROVED BY A GEOTECHNICAL ENGINEER.
9. MASTER PLAN DEVELOPMENTS PER BEND DEVELOPMENT CODE 4.5.100(E)(2)(C) MAY PROPOSE MODIFIED STREET SECTIONS THAT INCLUDE ADDITIONS TO OR ENHANCEMENTS OF THE BASIC MINIMUM STANDARD SECTIONS SHOWN HERE.
10. OFF STREET SHARED-USE PATHS (PATHS MEETING THE GENERAL ALIGNMENT OF THE TSP LOW STRESS NETWORK AND ARE MORE THAN 30 FT OUTSIDE OF THE RIGHT-OF-WAY) ARE ENCOURAGED, PARTICULARLY ALONG ARTERIAL STREET CORRIDORS. SIDEWALKS MAY BE REDUCED TO A MINIMUM 6 FT OR ELIMINATED WHEN THE SAME SIDE OF THE ROAD CORRIDOR IS SERVED BY A SHARED-USE PATH DEPENDING ON ADJACENT LAND USE AND PEDESTRIAN/BIKE ACCESS AND WITH CITY ENGINEER APPROVAL.
11. TWELVE-FOOT CENTER MEDIAN ON ARTERIAL AND COLLECTOR CROSS-SECTIONS INCLUDES EITHER A STRIPED MEDIAN (TWO-WAY LEFT TURN LANE, DOUBLE YELLOW, AND/OR TURN BAY) OR A NINE-FOOT RAISED REFUGE ISLAND WITH A ONE AND A HALF FOOT SHY LINE STRIPE EACH SIDE AS REQUIRED PER STANDARDS.
12. RAISED MEDIANS ARE AT THE CITY ENGINEER'S DISCRETION ON ARTERIALS & COLLECTORS. MEDIAN REFUGE ISLANDS FOR STREET CROSSINGS ON A LOW STRESS ROUTE OR AN ENHANCED CROSSING ON A CONNECTOR ROUTE DO NOT REQUIRE CITY ENGINEER APPROVAL.
13. ON-STREET PARKING SPACES ARE NOT STRIPED. IN HIGH PARKING DEMAND AREAS, A PARKING LINE MAY BE USED WITH CITY ENGINEER APPROVAL.
14. SEE BEND DEVELOPMENT CODE 3.4.200(F)(3) FOR STREETS AND INTERSECTIONS NOT IDENTIFIED FOR TRAVEL LANE EXPANSION WHERE ADDITIONAL RIGHT-OF-WAY IS NOT REQUIRED FOR VEHICLE TRAVEL LANES.
15. PLTS = PEDESTRIAN LEVEL OF TRAFFIC STRESS / BLTS = BICYCLISTS LEVEL OF TRAFFIC STRESS.
16. DEVIATIONS FROM THE PAVEMENT SECTIONS PROVIDED IN THE TABLE BELOW REQUIRE A STAMPED GEOTECHNICAL REPORT. PCC ROADWAYS REQUIRE A STAMPED GEOTECHNICAL REPORT.
17. SEE CITY SPEC 00744/00745 FOR MAXIMUM AC PAVEMENT LIFT THICKNESS.
18. WHERE EXISTING GROUND CROSS SLOPE EXCEEDS 12%, CURB-TIGHT SIDEWALK IS ALLOWED PER DESIGN STANDARD 3.4.7 - HILLSIDE.

STREET TYPE	"A" ROW	"B" STREET	"C" SIDEWALK	"D" CURB	"E" ACP DEPTH/LEVEL	"F" BASE	"G" CUT/FILL
ARTERIAL	PER R-1A			7"/16"	8" - LEVEL III	10"	4H:1V
COLLECTOR	PER R-1B & R-1C			6"/14"	6" - LEVEL III	8"	4H:1V
LOCAL	PER R-1D & R-1E			6"/12"	4" - LEVEL III	6"	2H:1V
INDUSTRIAL LOCAL	PER R-1F			6"/12"	4" - LEVEL III	8"	2H:1V
ALLEY	PER R-1G			--	4" - LEVEL III	6"	2H:1V
ROUNDAABOUT - ACP	VARIES	VARIES	VARIES	**	8" - LEVEL IV	10"	4H:1V
ROUNDAABOUT - PCC ***	VARIES	VARIES	VARIES	**	*	*	4H:1V

* THE STANDARD PAVEMENT SECTION FOR ARTERIAL STREETS IS ASPHALT. FOR RECONSTRUCTION, NEW STREETS MORE THAN 1/4 MILE LONG, AND FOR ROUNDABOUTS, A LIFE CYCLE COST ANALYSIS EVALUATING ASPHALT, PERPETUAL PAVEMENT, CONCRETE, AND OTHER SECTIONS SHALL BE SUBMITTED TO AND APPROVED BY THE CITY ENGINEER.

* CURBS AT ROUNDABOUTS AND ON SPLITTER ISLANDS SHALL BE HIGH-STRENGTH PER CITY SPEC 00759.13.

*** DOWELING REQUIRED AT ROUNDABOUT JOINTS

DRAWN AJD		<p align="center">CITY OF BEND STANDARD DRAWING 710 NW WALL ST., BEND, OREGON 97701</p>	SCALE NTS
DIV ROADWAY			DATE 01/31/2022
REV DATE			APPR
<p align="center">CITY OF BEND</p>		<p align="center">TYPICAL STREET CROSS-SECTIONS - GENERAL NOTES</p>	STD DWG R-1

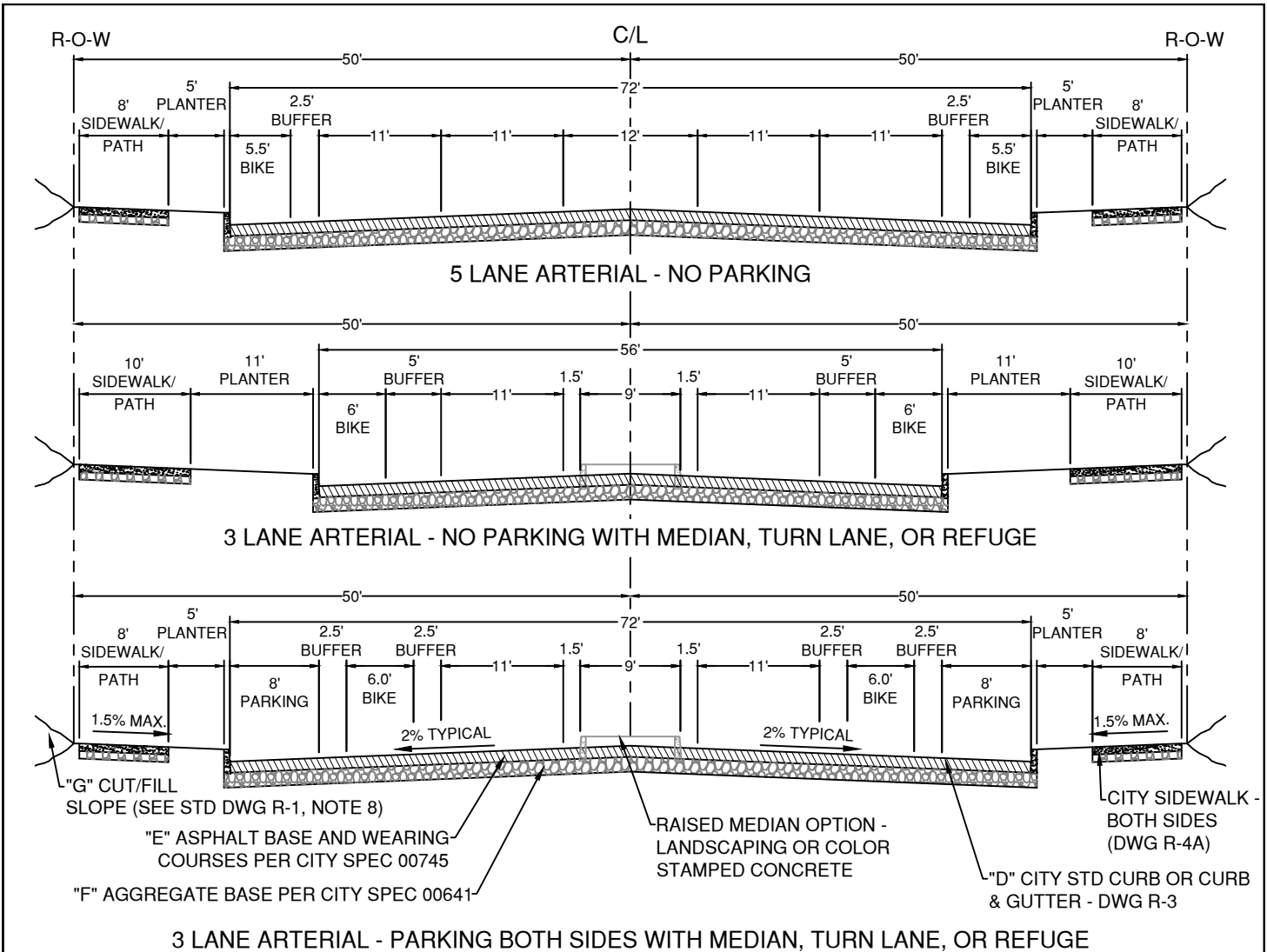

PLTS: 1 ≤ 35 MPH 2 ≥ 40 MPH	BLTS: 1 (SUP)	BLTS: 1 ≤ 30 MPH (BIKE LANE) 2 = 35 MPH 3 ≥ 40 MPH
--------------------------------	------------------	--

ARTERIAL GENERAL NOTES:

- SEE R-1 FOR GENERAL NOTES.
- WHERE PERMITTED BY THE BEND DEVELOPMENT CODE, ON-STREET PARKING MAY BE PROVIDED ON ARTERIAL STREETS WITH SPEEDS 35 MPH OR LESS. ON-STREET PARKING DESIGN PER ENGINEERING STANDARDS.
- PROTECTED BIKE LANES, OTHER THAN PARKING PROTECTED, REQUIRE CITY ENGINEER APPROVAL. PARKING PROTECTED BIKE LANES ALLOWED ON A CASE-BY-CASE BASIS.
- SIDEWALK MAY MEANDER WITH A MINIMUM 5 FT PLANTER STRIP. DESIGN MEANDERING CURVES FOR 10 MPH.
- FOR EXISTING ARTERIAL SECTIONS IN 100 FT RIGHT-OF-WAY WITH 52 FT PAVEMENT WIDTHS, THE CITY ENGINEER MAY APPROVE REDUCING THE BIKE LANE TO 6/2.5 FT TO MATCH THE 52 FT CURB-TO-CURB EXISTING CONSTRUCTED SECTIONS; EXCEPTION DOES NOT APPLY TO SECTIONS (NEW OR RECONSTRUCTED) AT THE OUTER EXTENTS OF THE NETWORK WHERE UNDEVELOPED LAND AND FUTURE EXPANSIONS/RECONSTRUCTIONS CAN ACCOMMODATE THE 56/72 FT PAVEMENT SECTION.
- THE FIVE-LANE ARTERIAL SECTION IS TO BE USED ON 3RD STREET, 27TH STREET SOUTH OF NEFF ROAD, REED MARKET ROAD EAST OF US 97, AND OTHER MAJOR ARTERIAL STREETS AS IDENTIFIED BY A TRAFFIC ANALYSIS WITH CITY ENGINEER APPROVAL (SEE STANDARDS FOR LANE ADDITIONS).
- PARKING IS NOT PERMITTED ON A FIVE LANE ARTERIAL.
- FOR PARKING ON ONE SIDE OF A THREE LANE ARTERIAL, COMBINE THE APPLICABLE HALF STREET SECTIONS FROM THE NO PARKING AND PARKING ON BOTH SIDES TYPICAL SECTIONS. THE ROAD CENTERLINE SHALL REMAIN IN THE CENTER OF ROW TO ALLOW FOR FUTURE EXPANSION.

DRAWN	AJD
DIV	ROADWAY
REV	DATE



CITY OF BEND
 STANDARD DRAWING
 710 NW WALL ST., BEND, OREGON 97701

TYPICAL STREET CROSS-SECTIONS - ARTERIAL

SCALE	NTS
DATE	01/31/2022
APPR	
STD DWG	R-1A

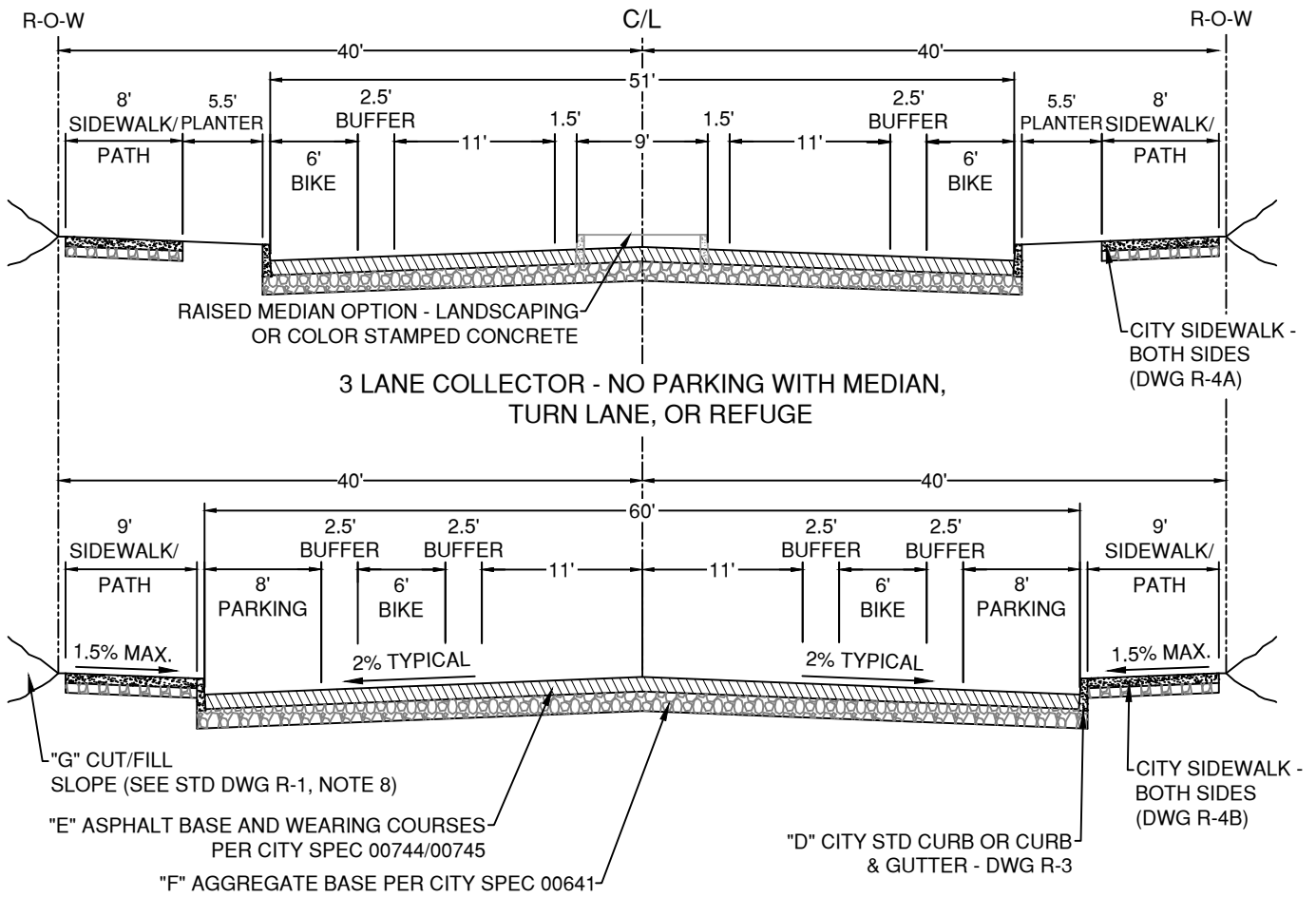

PLTS: 1 ≤ 35 MPH	BLTS: 1	BLTS: 1 ≤ 30 MPH
2 ≥ 40 MPH	(SUP)	(BIKE LANE) 2 = 35 MPH
		3 ≥ 40 MPH

MAJOR COLLECTOR GENERAL NOTES:

- SEE R-1 FOR GENERAL NOTES.
- WHERE PERMITTED BY THE BEND DEVELOPMENT CODE, ON-STREET PARKING MAY BE PROVIDED ON COLLECTOR STREETS WITH SPEEDS 35 MPH OR LESS. ON-STREET PARKING DESIGN PER ENGINEERING STANDARDS.
- WHERE THE CROSS-SECTION DOES NOT PROVIDE FOR TREES IN A PLANTER STRIP, DEVELOPMENT MUST STILL MEET BEND DEVELOPMENT CODE TREE REQUIREMENTS IN AN ALTERNATE LOCATION ON-SITE OR PROVIDE MITIGATION AND RECEIVE APPROVAL OF A VARIANCE AS REQUIRED BY CODE.
- PROTECTED BIKE LANES, OTHER THAN PARKING PROTECTED, REQUIRE CITY ENGINEER APPROVAL. PARKING PROTECTED BIKE LANES ALLOWED ON A CASE-BY-CASE BASIS.
- SIDEWALK MAY MEANDER WITH A MINIMUM 5 FT PLANTER STRIP. DESIGN MEANDERING CURVES FOR 10 MPH.

DRAWN AJD	
DIV ROADWAY	
REV	DATE



CITY OF BEND
STANDARD DRAWING
710 NW WALL ST., BEND, OREGON 97701

TYPICAL STREET CROSS-SECTIONS - MAJOR COLLECTOR

SCALE NTS
DATE 07/02/2025
APPR
STD DWG R-1B

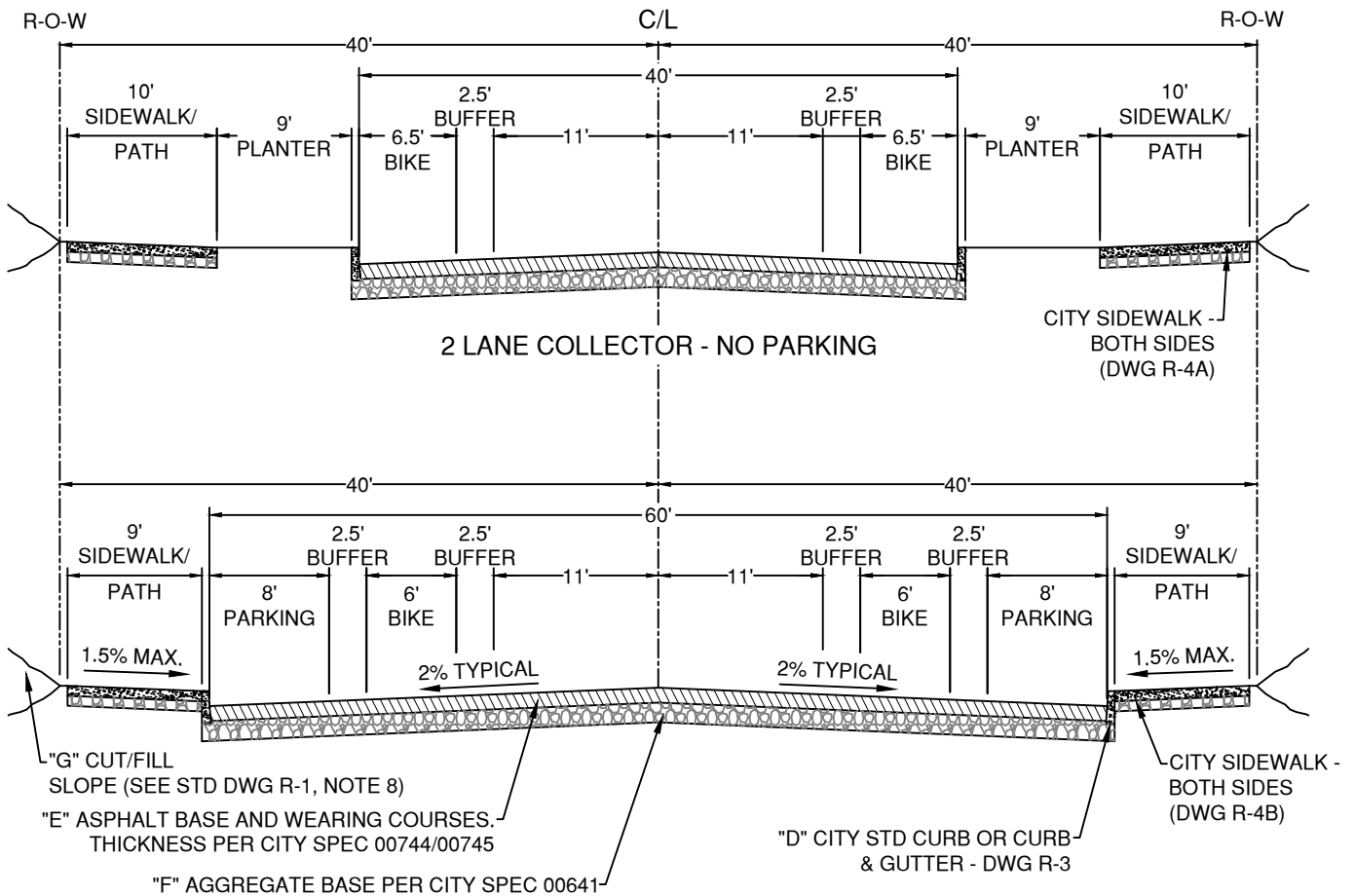

2 LANE COLLECTOR - PARKING BOTH SIDES

PLTS: 1 ≤ 35 MPH	BLTS: 1	BLTS: 1 ≤ 30 MPH
2 ≥ 40 MPH	(SUP)	(BIKE LANE) 2 = 35 MPH
		3 ≥ 40 MPH

MINOR COLLECTOR GENERAL NOTES:

- SEE R-1 FOR GENERAL NOTES.
- WHERE PERMITTED BY THE BEND DEVELOPMENT CODE, ON-STREET PARKING MAY BE PROVIDED ON COLLECTOR STREETS WITH SPEEDS 35 MPH OR LESS. ON-STREET PARKING DESIGN PER ENGINEERING STANDARDS.
- WHERE THE CROSS-SECTION DOES NOT PROVIDE FOR TREES IN A PLANTER STRIP, DEVELOPMENT MUST STILL MEET BEND DEVELOPMENT CODE TREE REQUIREMENTS IN AN ALTERNATE LOCATION ON-SITE OR PROVIDE MITIGATION AND RECEIVE APPROVAL OF A VARIANCE AS REQUIRED BY CODE.
- PROTECTED BIKE LANES, OTHER THAN PARKING PROTECTED, REQUIRE CITY ENGINEER APPROVAL. PARKING PROTECTED BIKE LANES ALLOWED ON A CASE-BY-CASE BASIS.
- SIDEWALK MAY MEANDER WITH A MINIMUM 5 FT PLANTER STRIP. DESIGN MEANDERING CURVES FOR 10 MPH.
- FOR PARKING ON ONE SIDE, COMBINE THE APPLICABLE HALF STREET SECTIONS FROM THE NO PARKING AND PARKING ON BOTH SIDES TYPICAL SECTIONS. THE ROAD CENTERLINE SHALL REMAIN IN THE CENTER OF ROW TO ALLOW FOR FUTURE EXPANSION.

DRAWN	AJD
DIV	ROADWAY
REV	DATE



CITY OF BEND

CITY OF BEND

STANDARD DRAWING

710 NW WALL ST., BEND, OREGON 97701

TYPICAL STREET CROSS-SECTIONS - MINOR COLLECTOR

SCALE	NTS
DATE	07/02/2025
APPR	
STD DWG	R-1C

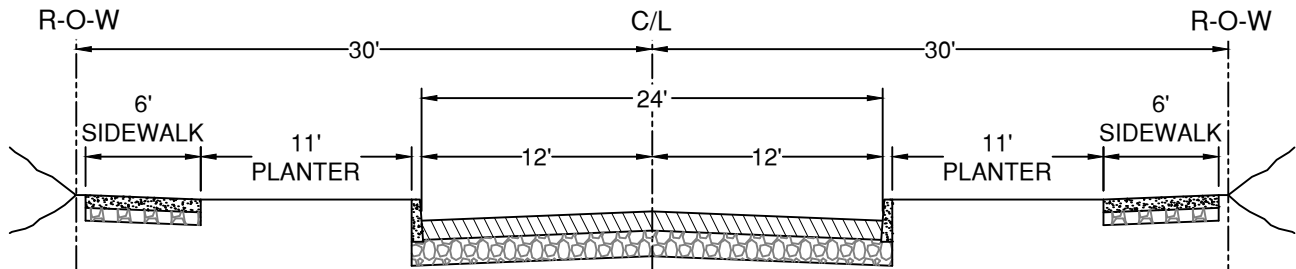

LOCAL ROAD - NO PARKING

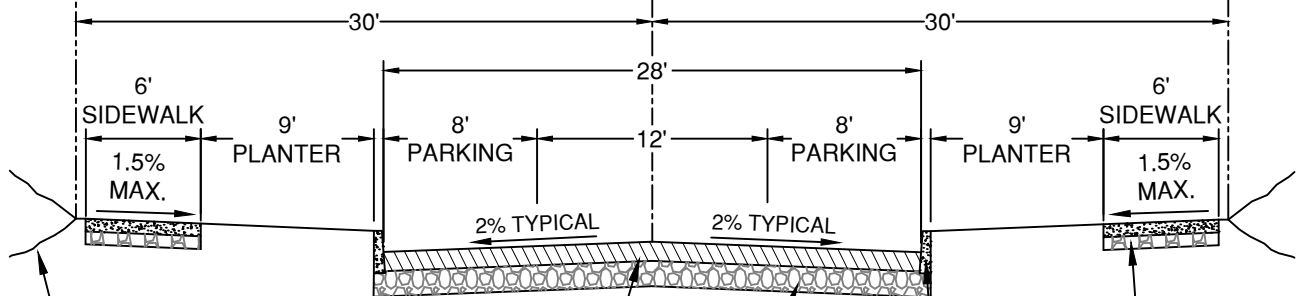

28' LOCAL ROAD - PARKING BOTH SIDES (SEE NOTE 3)

- "G" CUT/FILL SLOPE (SEE STD DWG R-1, NOTE 8)
- "E" ASPHALT BASE AND WEARING COURSES. THICKNESS PER CITY SPEC 00744/00745
- "F" AGGREGATE BASE PER CITY SPEC 00641
- "D" CITY STD CURB OR CURB & GUTTER - DWG R-3
- CITY SIDEWALK - BOTH SIDES (DWG R-4A)

PLTS:1 BLTS:1
2 (STRIPED CENTERLINE)

LOCAL ROAD GENERAL NOTES:

1. SEE R-1 FOR GENERAL NOTES
2. UTILITY EASEMENTS MAY BE REQUIRED FOR PEDESTALS, TRANSFORMERS, ETC.
3. LOCAL ROADS WITH TRAVEL LANES LESS THAN 10' IN EACH DIRECTION ARE CONSIDERED QUEUING STREETS. SEE DESIGN STANDARDS SECTION 3.4.2.2 FOR APPROPRIATE QUEUING STREET APPLICATIONS.

DRAWN AJD	
DIV ROADWAY	
REV	DATE



CITY OF BEND
STANDARD DRAWING
710 NW WALL ST., BEND, OREGON 97701

TYPICAL STREET CROSS-SECTION - LOCAL

SCALE NTS
DATE 07/02/2025
APPR
STD DWG R-1D

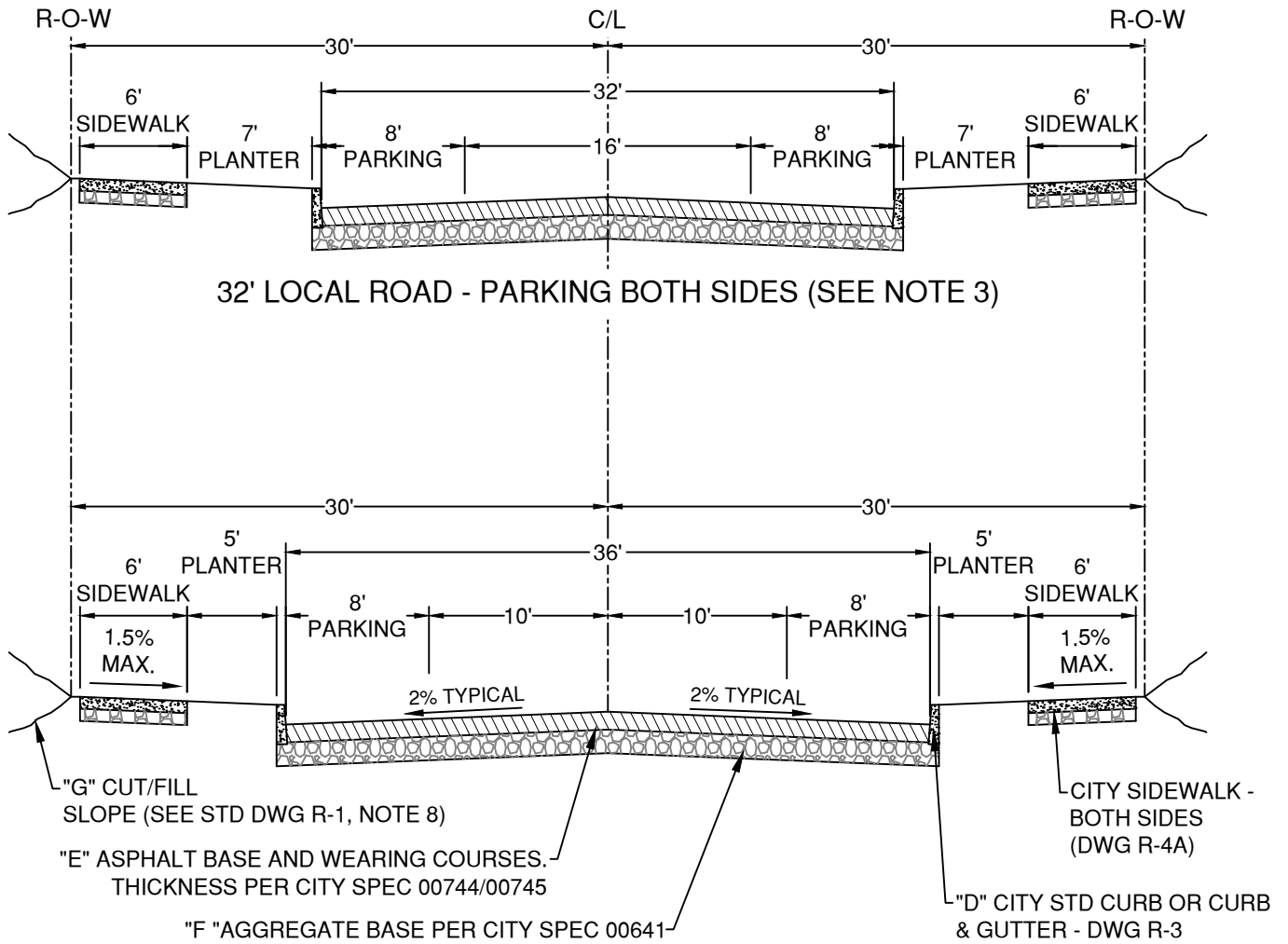

PLTS:1 BLTS:1
2 (STRIPED CENTERLINE)

LOCAL ROAD GENERAL NOTES:

1. SEE R-1 FOR GENERAL NOTES
2. UTILITY EASEMENTS MAY BE REQUIRED FOR PEDESTALS, TRANSFORMERS, ETC.
3. LOCAL ROADS WITH TRAVEL LANES LESS THAN 10' IN EACH DIRECTION ARE CONSIDERED QUEUING STREETS. SEE DESIGN STANDARDS SECTION 3.4.2.2 FOR APPROPRIATE QUEUING STREET APPLICATIONS.

DRAWN AJD	
DIV ROADWAY	
REV	DATE



CITY OF BEND
STANDARD DRAWING
710 NW WALL ST., BEND, OREGON 97701

TYPICAL STREET CROSS-SECTION - LOCAL

SCALE NTS
DATE 07/02/2025
APPR
STD DWG R-1E

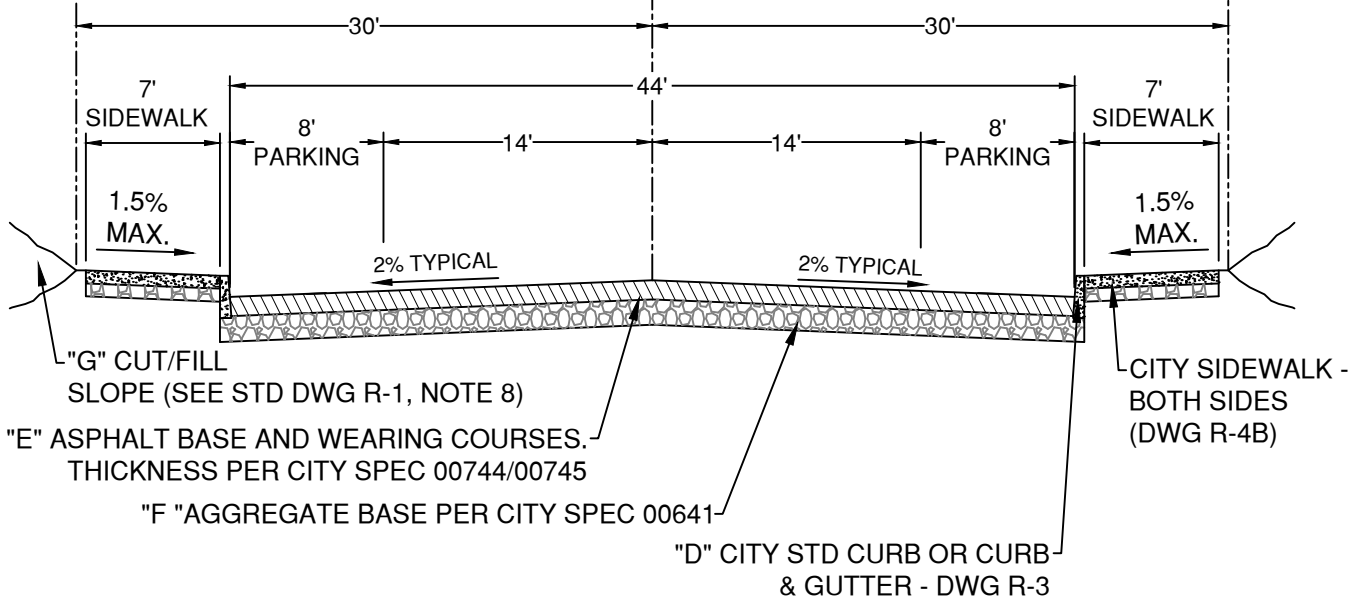
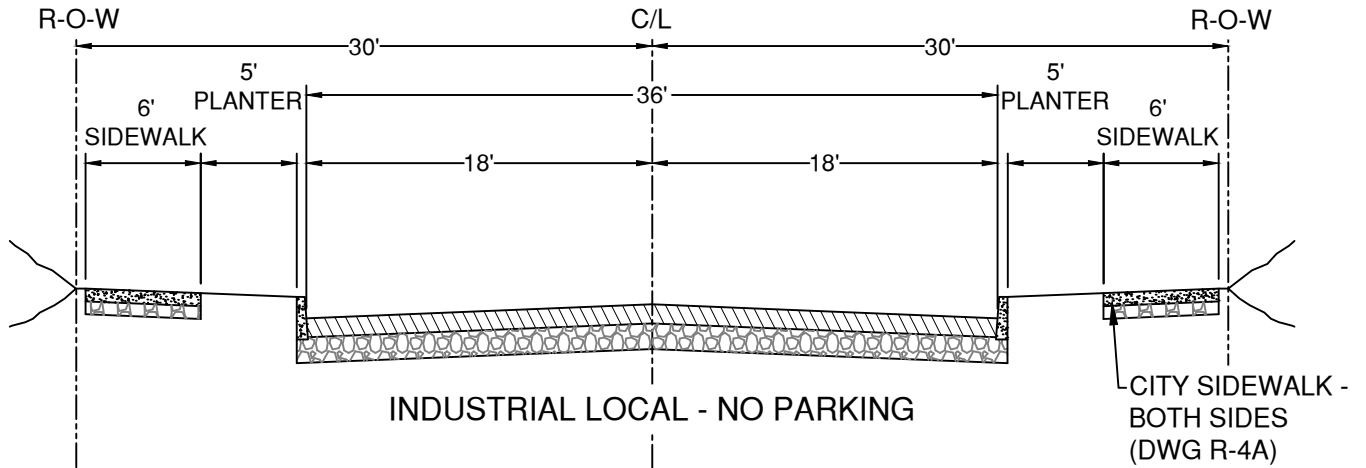

PLTS:1 BLTS:1
 2 (STRIPED CENTERLINE)

LOCAL ROAD GENERAL NOTES:

1. SEE R-1 FOR GENERAL NOTES
2. THE SIDE PARKING IS ON MAY ALTERNATE BY BLOCK. PROVIDE PARKING NEXT TO PARKS, SCHOOLS, AND OTHER ACTIVITY GENERATING LAND USES.
3. UTILITY EASEMENTS MAY BE REQUIRED FOR PEDESTALS, TRANSFORMERS, ETC.
4. FOR PARKING ON ONE SIDE, COMBINE THE APPLICABLE HALF STREET SECTIONS FROM THE NO PARKING AND PARKING ON BOTH SIDES TYPICAL SECTIONS. THE ROAD CENTERLINE SHALL REMAIN IN THE CENTER OF ROW TO ALLOW FOR FUTURE EXPANSION.

DRAWN AJD	
DIV ROADWAY	
REV	DATE



CITY OF BEND
 STANDARD DRAWING
 710 NW WALL ST., BEND, OREGON 97701

TYPICAL STREET CROSS-SECTION - INDUSTRIAL LOCAL

SCALE NTS
DATE 07/02/2025
APPR
STD DWG R-1F

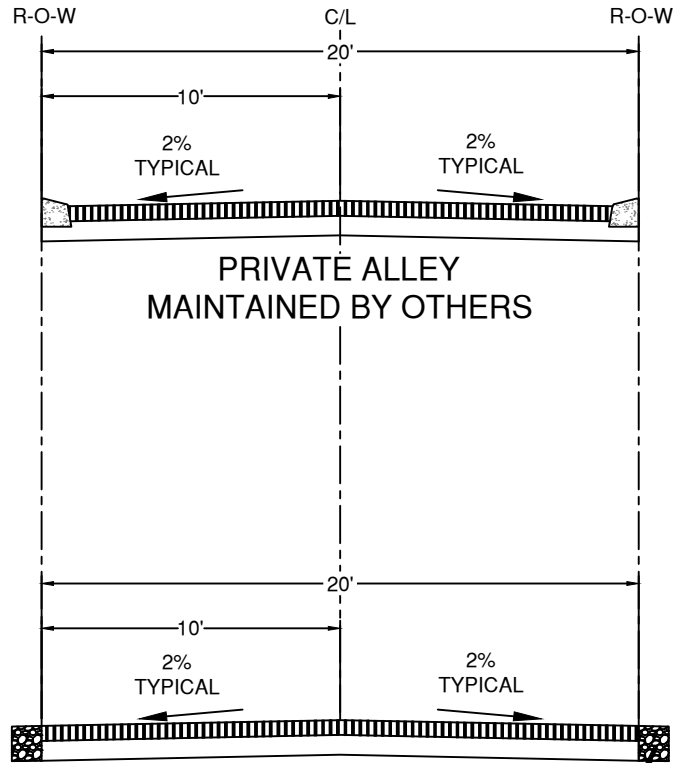
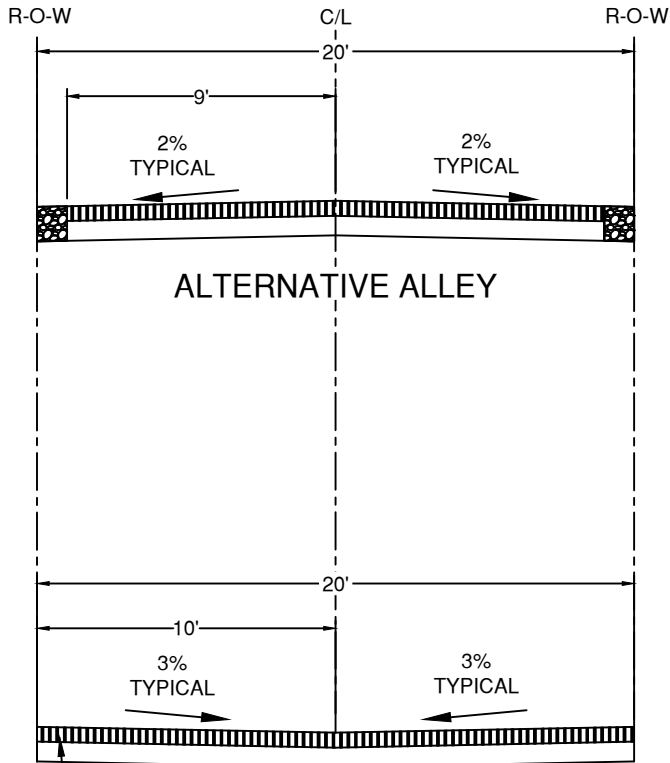

ALTERNATIVE ALLEY

PRIVATE ALLEY
MAINTAINED BY OTHERS

ALTERNATIVE ALLEY

STANDARD ALLEY

ASPHALT BASE AND WEARING COURSES.
THICKNESS PER "E" IN TABLE ON STD
DWG R-1 AND PER CITY SPEC 00744

AGGREGATE BASE PER "F" IN
TABLE ON STD DWG R-1 AND
PER CITY SPEC 00640

ALLEY GENERAL NOTES:

1. SEE R-1 FOR GENERAL NOTES.
2. NEW ALLEY RIGHT-OF-WAY AND PAVED WIDTH WILL BE 20' WIDE. WHERE ALLEYS ARE INSTALLED IN EXISTING RIGHT-OF-WAY, THE PAVED WIDTH MAY BE UP TO 2 FEET LESS THAN THE RIGHT-OF-WAY WIDTH. 1-FOOT WIDE BUFFERS ON EACH SIDE OF THE ALLEY MAY BE LEFT UNPAVED WHEN ALLEYS ARE INSTALLED IN EXISTING RIGHT-OF-WAY.
3. SURFACE RESTORATION OF TRANSVERSE TRENCHING WILL NOT REQUIRE ASPHALT IF THE EXISTING ALLEY IS UNPAVED. RESTORE SURFACE TO MATCH EXISTING.

DRAWN	AJD
DIV	ROADWAY
REV	DATE



CITY OF BEND

CITY OF BEND
STANDARD DRAWING

710 NW WALL ST., BEND, OREGON 97701

TYPICAL STREET SECTION - ALLEY

SCALE	NTS
DATE	01/31/2022
APPR	
STD DWG	R-1G

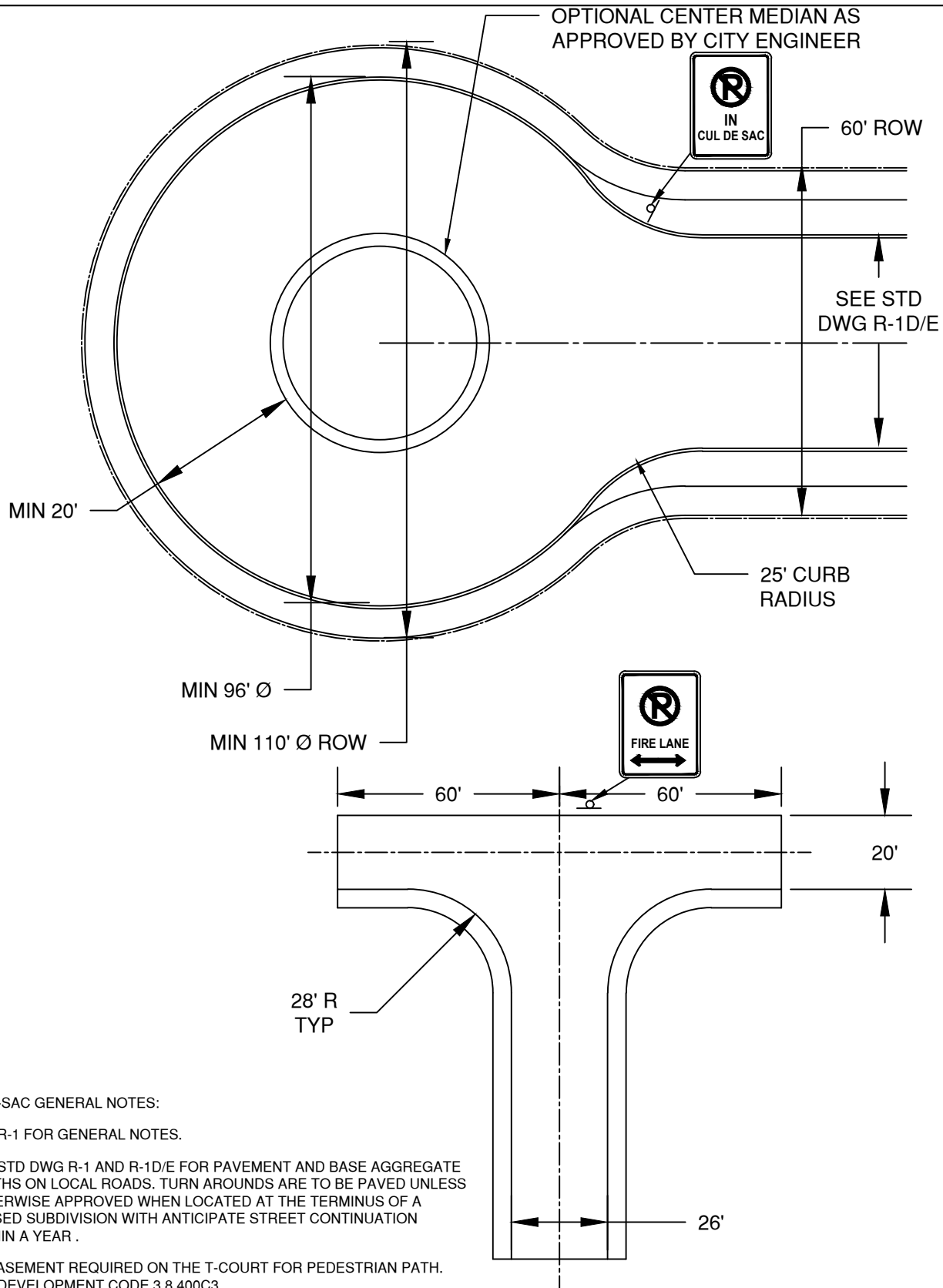

CUL-DE-SAC GENERAL NOTES:

1. SEE R-1 FOR GENERAL NOTES.
2. SEE STD DWG R-1 AND R-1D/E FOR PAVEMENT AND BASE AGGREGATE DEPTHS ON LOCAL ROADS. TURN AROUNDS ARE TO BE PAVED UNLESS OTHERWISE APPROVED WHEN LOCATED AT THE TERMINUS OF A PHASED SUBDIVISION WITH ANTICIPATE STREET CONTINUATION WITHIN A YEAR .
3. 10' EASEMENT REQUIRED ON THE T-COURT FOR PEDESTRIAN PATH. SEE DEVELOPMENT CODE 3.8.400C3
4. TURN AROUNDS TO BE IN COMPLIANCE WITH OREGON FIRE CODE.

DRAWN AJD	
DIV ROADWAY	
REV	DATE



CITY OF BEND

CITY OF BEND

STANDARD DRAWING

710 NW WALL ST., BEND, OREGON 97701

TYPICAL STREET DEAD-END TURNAROUND

SCALE NTS

DATE 11/01/2024

APPR

STD DWG R-1H

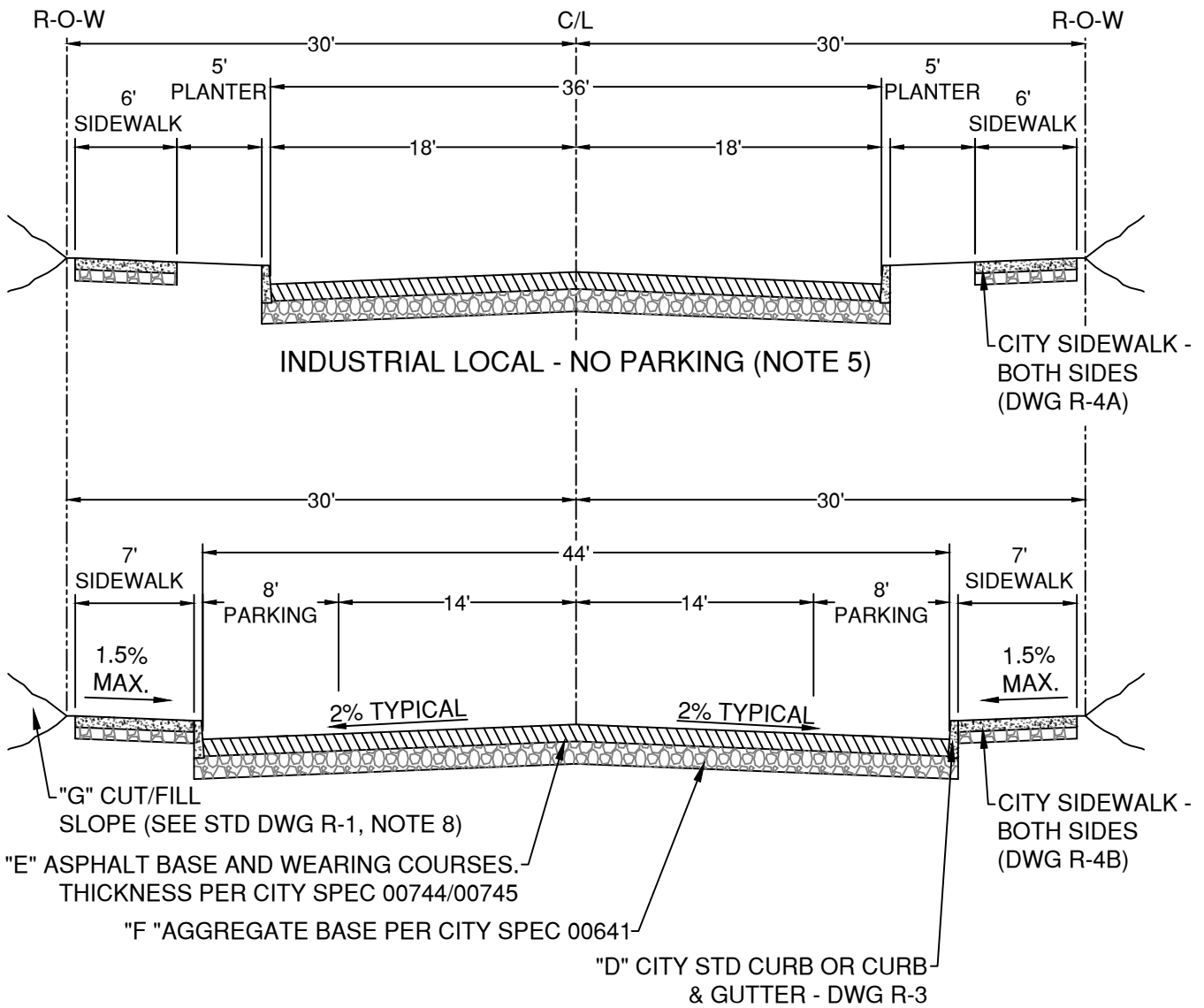

PLTS:1	BLTS:1 2 (STRIPED CENTERLINE)
--------	----------------------------------

LOCAL ROAD GENERAL NOTES:

1. SEE R-1 FOR GENERAL NOTES
2. THE SIDE PARKING IS ON MAY ALTERNATE BY BLOCK. PROVIDE PARKING NEXT TO PARKS, SCHOOLS, AND OTHER ACTIVITY GENERATING LAND USES.
3. UTILITY EASEMENTS MAY BE REQUIRED FOR PEDESTALS, TRANSFORMERS, ETC.
4. FOR PARKING ON ONE SIDE, COMBINE THE APPLICABLE HALF STREET SECTIONS FROM THE NO PARKING AND PARKING ON BOTH SIDES TYPICAL SECTIONS. THE ROAD CENTERLINE SHALL REMAIN IN THE CENTER OF ROW TO ALLOW FOR FUTURE EXPANSION.
5. ON-SITE PARKING MAY BE PERMITTED WHEN PARKING IS RESTRICTED WITHIN 100 FEET OF INTERSECTIONS ON BLOCKS WHERE LAND USE / SITE DESIGN DOES NOT SERVE LARGER VEHICLES

DRAWN AJD	 CITY OF BEND	CITY OF BEND STANDARD DRAWING 710 NW WALL ST., BEND, OREGON 97701	SCALE NTS
DIV			DATE 04/16/2026
REV DATE			APPR
		TYPICAL STREET CROSS-SECTION -INDUSTRIAL LOCAL	STD DWG R-1F

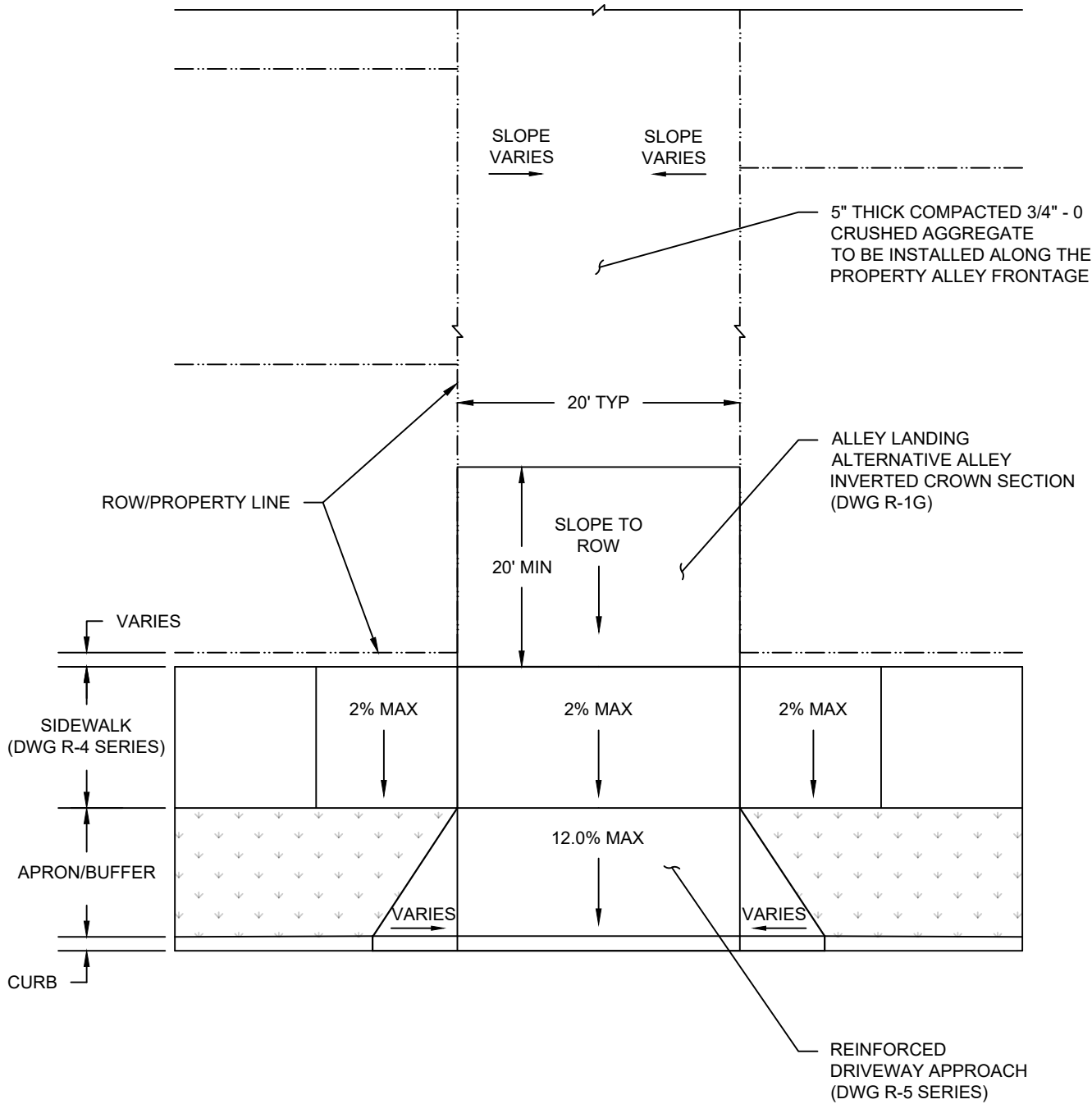

GENERAL NOTES:

1. IF THERE IS ALLEY ACCESS TO THE PROPERTY AND ONE OR MORE OF THE ALLEY DRIVEWAY APPROACHES ARE NOT IMPROVED TO CITY OF BEND STANDARDS AND SPECIFICATIONS, THEN AN ALLEY APPROACH MUST BE IMPROVED TO CITY OF BEND STANDARDS AND SPECIFICATIONS WITH THE PROPOSED DEVELOPMENT.
2. REFER TO THE BEND DEVELOPMENT CODE 4.2.400 FOR ADDITIONAL MINIMUM DEVELOPMENT STANDARDS REQUIREMENTS.

DRAWN DSE	
DIV ROADWAY	
REV	DATE



CITY OF BEND

CITY OF BEND

STANDARD DRAWING

710 NW WALL ST., BEND, OREGON 97701

RESIDENTIAL ALLEY IMPROVEMENTS

SCALE NTS

DATE 04/21/2023

APPR

STD DWG R-1J

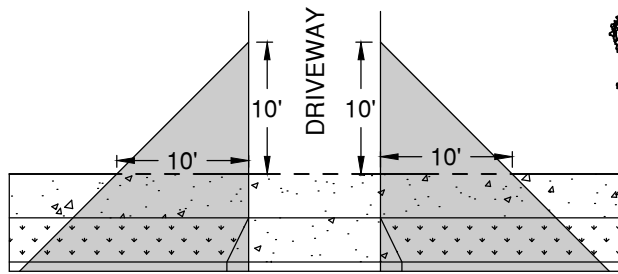

DRIVEWAY AND STREET INTERSECTION (SEE NOTE 5)

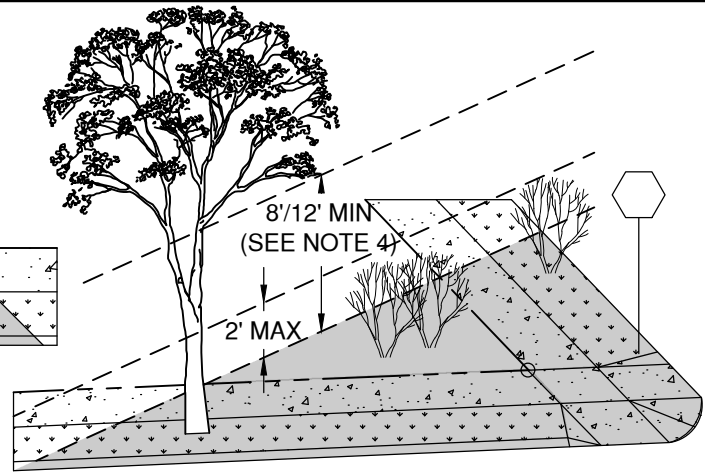

MAX HEIGHT OF SHRUBS AND MINIMUM LIMBING REQUIRED IN CLEAR VISION AREA

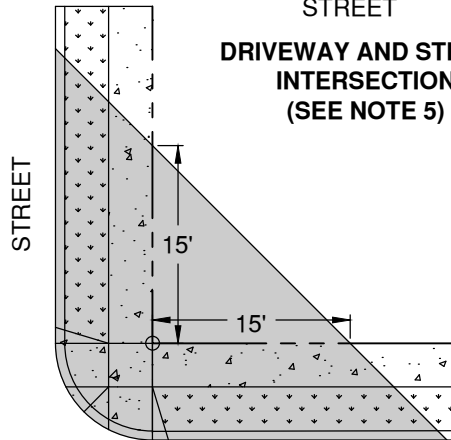

STREET/STREET INTERSECTION

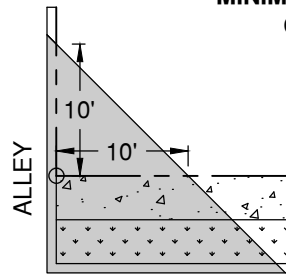

STREET/ALLEY INTERSECTION

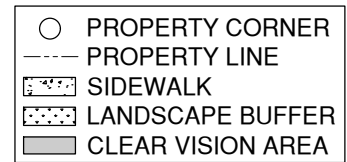

CLEAR VISION AREAS ARE ESTABLISHED AS FOLLOWS:

- 1) CLEAR VISION TRIANGLES SHALL BE ESTABLISHED AT THE CORNER OF ANY PROPERTY ADJACENT TO INTERSECTIONS OF PUBLIC OR PRIVATE STREETS, ALLEYS, MID-BLOCK LANES, AND/OR RAILROAD RIGHTS-OF-WAY.
- 2) THE TWO LEGS OF THE CLEAR VISION TRIANGLE ARE EACH MEASURED FROM THE POINT OF INTERSECTION OF THE TWO CORNER LOT LINES, SPECIAL SETBACK LINES, OR ACCESS EASEMENT LINES. WHERE LOT LINES HAVE ROUNDED CORNERS, THE LOT LINES ARE EXTENDED IN A STRAIGHT LINE TO A POINT OF INTERSECTION. THE CLEAR VISION AREA EXTENDS TO THE FACE OF CURB AT THE STREET OR ALLEY
- 3) THE LENGTH OF BOTH LEGS OF THE CLEAR VISION AREA TRIANGLE IS AS FOLLOWS:
 TYPICAL, ALL ZONES: 15 FEET
 RAILROADS: 15 FEET
 ALLEY INTERSECTION: 10 FEET
 DRIVEWAYS: 10 FEET
- 4) WITHIN THE CLEAR VISION AREA, OBSTRUCTIONS TO VISION OTHER THAN A STREET SIGN, HYDRANT, CROSSWALK CLOSED SIGNS, SIGN POST, OR POLE LESS THAN 8 INCHES IN DIAMETER SHALL BE CLEARED FROM PROPERTY UNDER THE CONTROL OF THE CITY, HOMEOWNER, OR DEVELOPER. SHRUBS OR FOLIAGE MUST NOT EXCEED 2'-0" IN HEIGHT. PLANTING NEW TREES OR INSTALLATION OF COMMUNICATION TOWERS AND TRANSFORMERS, ARE NOT PERMITTED WITHIN THE CLEAR VISION AREA. EXISTING TREES MUST BE MAINTAINED/LIMBED TO A MINIMUM OF 8'-0" ABOVE THE TOP OF CURB OR 12'-0" ABOVE ADJACENT BIKE LANES.
- 5) DRIVEWAY APPROACHES, ON-STREET PARKING AND DRIVEWAYS ARE NOT PERMITTED WITHIN THE CLEAR VISION AREA. ON-STREET PARKING DESIGN DOES NOT INCLUDE SPACES WITHIN 20 FEET OF AN ACCESSIBLE RAMP OR WITHIN 10 FEET OF A DRIVEWAY APPROACH.

NOTE: INTERSECTION SIGHT TRIANGLES ARE DISTINCT FROM, AND IN ADDITION TO, CLEAR VISION AREAS. INTERSECTION SIGHT TRIANGLE DIMENSIONS VARY WITH STREET WIDTH, GEOMETRY, TOPOGRAPHY, AND POSTED SPEED; ADDITIONAL CLEARING AS NECESSARY TO PROVIDE CLEAR INTERSECTION SIGHT DISTANCE IS ALSO REQUIRED; SEE CHAPTER 3.3 OF THE CITY OF BEND DESIGN STANDARDS.

DRAWN AJD	
DIV ROADWAY	
REV	DATE



CITY OF BEND

CITY OF BEND
STANDARD DRAWING

710 NW WALL ST., BEND, OREGON 97701

CLEAR VISION AREAS AT INTERSECTIONS

SCALE NTS
DATE 11/01/2024
APPR
STD DWG R-2

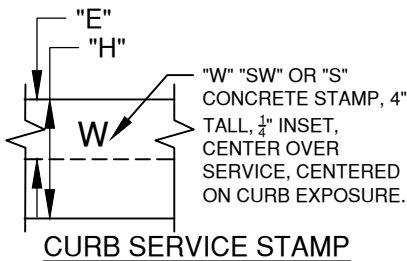
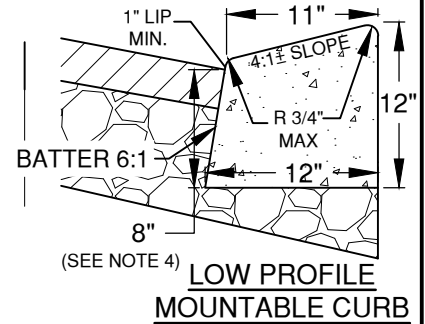
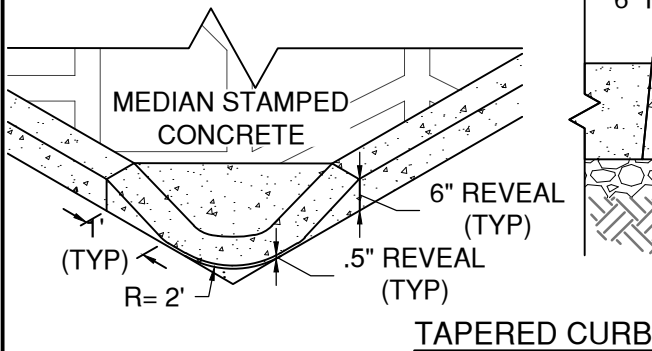
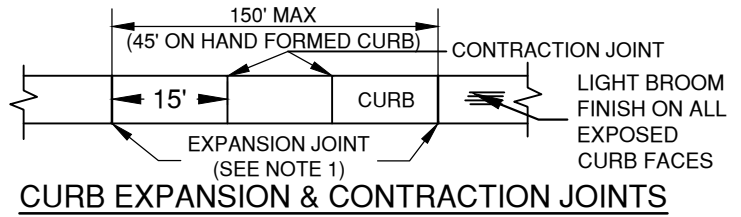
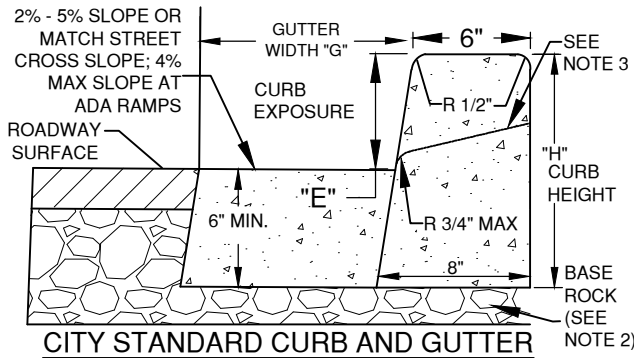
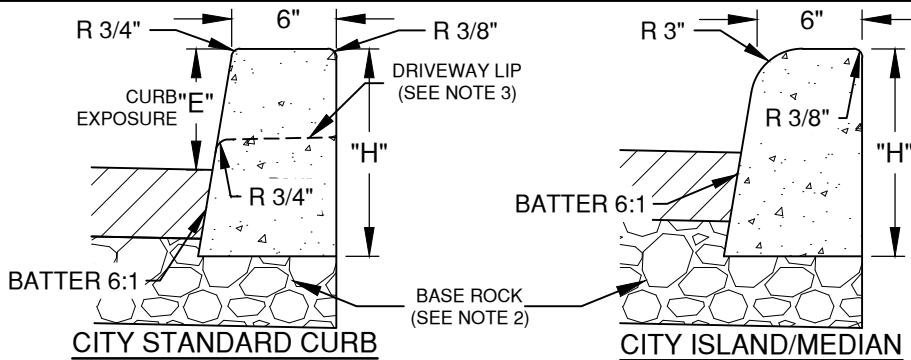

ROAD CLASS	CURB HEIGHT - H	CURB EXPOSURE - E	GUTTER WIDTH - G
ARTERIAL	16"	7"	12"
COLLECTOR	14"	6"	18"
LOCAL	12"	6"	18"

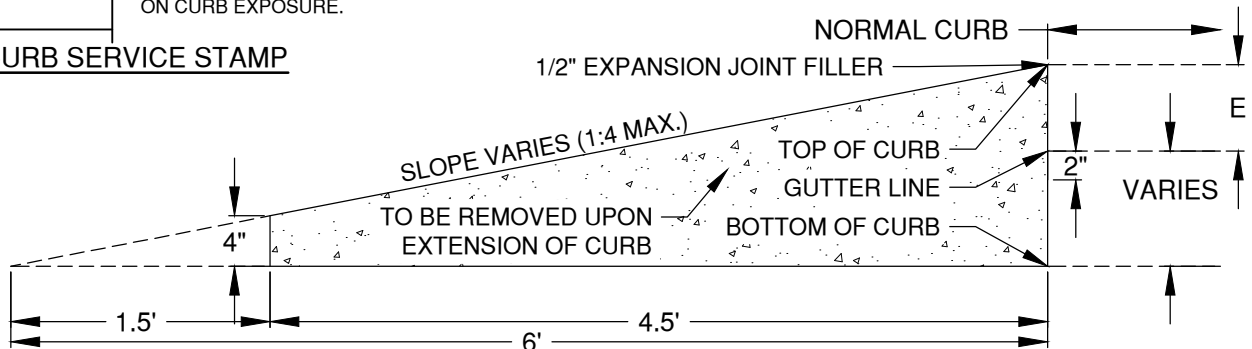

SEE NOTES ON STD DWG R-3A

DRAWN	AJD
DIV	ROADWAY
REV	DATE



CITY OF BEND
 STANDARD DRAWING
 710 NW WALL ST., BEND, OREGON 97701
CONCRETE CURB

SCALE	NTS
DATE	03/22/2023
APPR	
STD DWG	R-3

NOTES FOR STD DWG R-3:

1. EXPANSION JOINTS REQUIRED AT END OF RADII, DRIVEWAY APRONS, POINTS OF CURVATURE, AND NO GREATER THAN 150' MAXIMUM.
2. AGGREGATE BASE SHALL CONFORM TO SPECIFICATION SECTION 00640/00641. DEPTH AS REQUIRED TO MATCH BOTTOM OF STREET SECTION, 4" MIN.
3. SLOPE DRIVEWAY TOWARD STREET. 3/4" MAXIMUM LIP AT GUTTER, 1" ON COLLECTORS AND ARTERIALS.
4. MOUNTABLE CURB PERMITTED ON LOCAL STREET CUL-DE-SACS, ALLEYS, AND WHERE PERMITTED BY THE CITY ENGINEER. WHERE SIDEWALK ABUTS CURB, SIDEWALK SHALL BE MIN. 6" THICK
5. CURB AND GUTTER MAY BE REQUIRED WHEN GUTTER SLOPE IS BETWEEN 0.5% - 0.75%.
6. CONCRETE MATERIAL AND PLACEMENT SHALL CONFORM TO SPECIFICATION SECTION 00759.
7. LOCATE TAPERED CURB ON DOWNSTREAM SIDE OF PEDESTRIAN REFUGE IN CENTER MEDIAN CURB RAMPS TO PROTECT FROM SNOW PLOW DAMAGE.
8. TACK COAT IS TO BE APPLIED TO CURB FACE PRIOR TO PAVING.

DRAWN AJD	
DIV ROADWAY	
REV	DATE



CITY OF BEND

CITY OF BEND

STANDARD DRAWING

710 NW WALL ST., BEND, OREGON 97701

CONCRETE CURB NOTES

SCALE NTS
DATE 03/22/2023
APPR
STD DWG R-3A

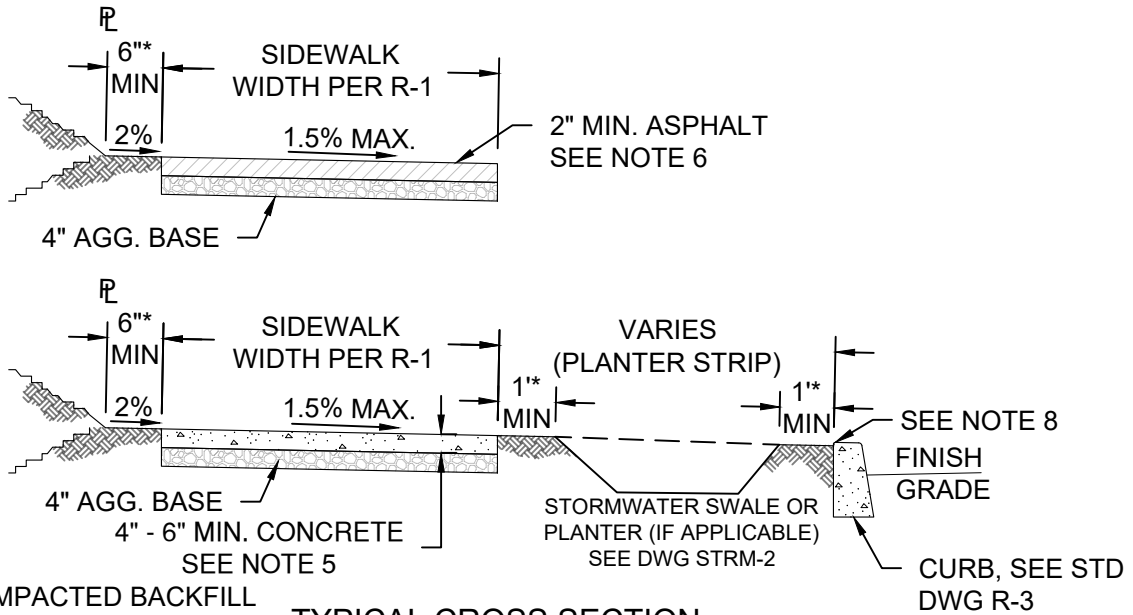

*PROVIDE COMPACTED BACKFILL ADJACENT TO CURB AND SIDEWALK

TYPICAL CROSS SECTION

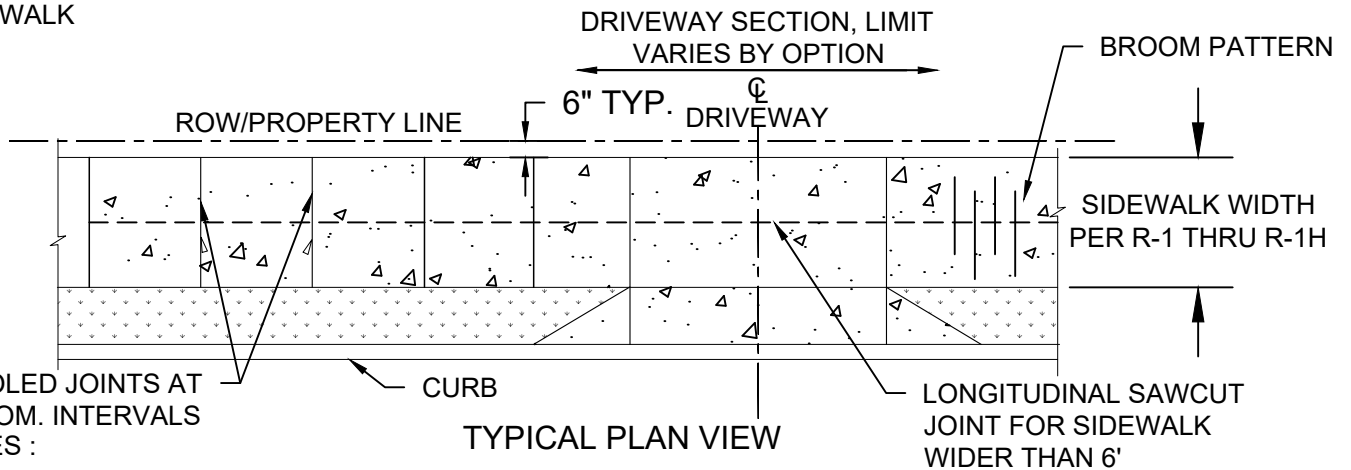

TYPICAL PLAN VIEW

- NOTES :
1. SIDEWALKS SET BACK ADJACENT TO PROPERTY LINE ARE STANDARD. USE CURB-TIGHT SIDEWALKS ONLY WHERE PERMITTED. SIDEWALK SHALL BE PROPERTY-TIGHT EXCEPT TO MEANDER AROUND TREES OR BARRIERS (UTILITIES, SIGNS, ETC.) OR PER DESIGN STANDARD SECTION 3.4.7 - HILLSIDE.
 2. CONST. EXPANSION JOINTS AT 25' MAXIMUM SPACING, AND AT POINTS OF TANGENCY, AND ON EACH SIDE OF DRIVEWAY APRONS. EXPANSION JOINTS MUST BE FULL DEPTH OF PAVING SECTION.
 3. CONST. CONTRACTION JOINTS AT 5' MAXIMUM SPACING, AND AT ENDS OF EACH RAMP.
 4. FOR DRIVEWAY DETAILS, SEE STD. DRGS. R-5A THROUGH R-5E.
 5. SIDEWALK THICKNESS MINIMUM 4" THICK , TYPICAL. MINIMUM 6" THICK IF SIDEWALK IS INTENDED AS PORTION OF DRIVEWAY, CURB RAMP, OR ADJACENT TO MOUNTABLE CURB.
 6. ASPHALT SHARED-USE PATH WHERE APPROVED BY THE ENGINEER.
 7. SIDEWALK BASE WILL BE VISUALLY INSPECTED FOR COMPACTION. CITY INSPECTORS CAN REQUIRE COMPACTION TESTING WHERE BASE ROCK COMPACTION IS VISUALLY OUT OF COMPLIANCE WITH SPECIFICATIONS 00640 / 00641.
 8. LANDSCAPING MUST BE 1/4 TO 1/2 INCH BELOW THE TOP OF ADJACENT SIDEWALK AND CURB.

DRAWN CJH DIV ROADWAY REV DATE		CITY OF BEND STANDARD DRAWING 710 NW WALL ST., BEND, OREGON 97701	SCALE NTS DATE 04/16/2026 APPR STD DWG R-4A
		SHARED-USE PATH/SIDEWALK, SETBACK	

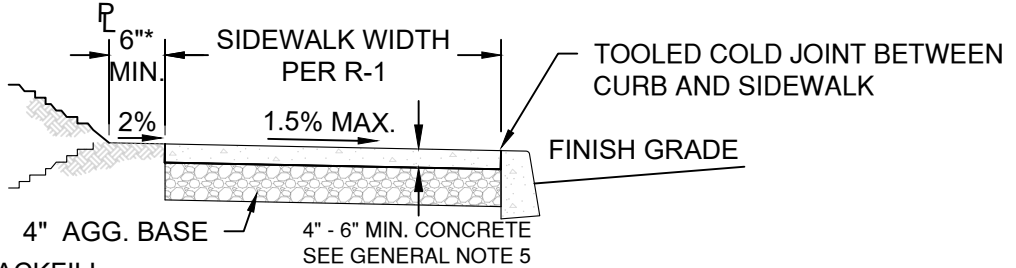
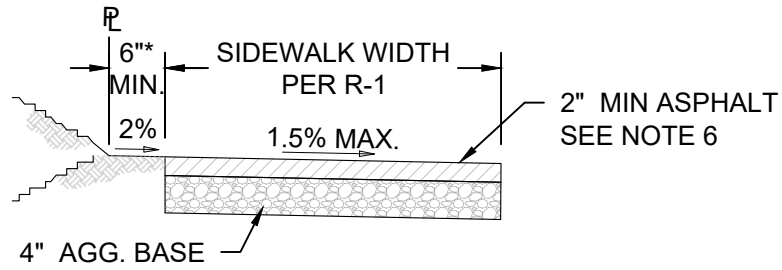

*PROVIDE COMPACTED BACKFILL ADJACENT TO CURB AND SIDEWALK

TYPICAL CROSS SECTION

DRIVEWAY SECTION, LIMIT VARIES BY OPTION

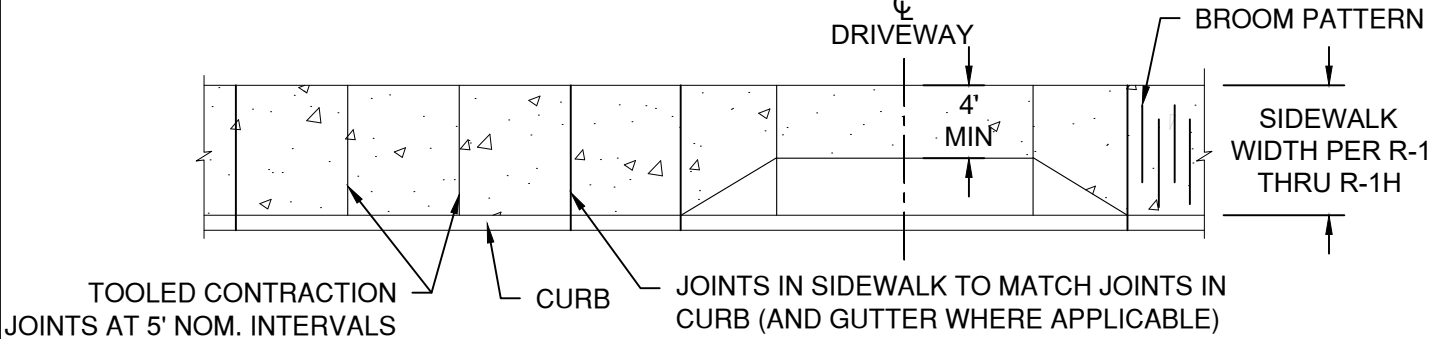

TYPICAL PLAN VIEW

NOTES:

1. SIDEWALKS SET BACK ADJACENT TO PROPERTY LINE ARE STANDARD. USE CURB-TIGHT SIDEWALKS ONLY WHERE PERMITTED.
2. CONST. EXPANSION JOINTS AT 25' MAXIMUM SPACING, AND AT POINTS OF TANGENCY, AND ON EACH SIDE OF DRIVEWAY APRONS. EXPANSION JOINTS MUST BE FULL DEPTH OF PAVING SECTION.
3. CONST. CONTRACTION JOINTS AT 5' MAXIMUM SPACING, AND AT ENDS OF EACH RAMP.
4. FOR DRIVEWAY DETAILS, SEE STD. DRGS. R-5A THROUGH R-5E.
5. SIDEWALK THICKNESS MINIMUM 4" THICK, TYPICAL. MINIMUM 6" THICK IF SIDEWALK IS PORTION OF DRIVEWAY, CURB RAMP, OR ADJACENT TO MOUNTABLE CURB.
6. ASPHALT SHARED-USE PATH WHERE APPROVED BY THE ENGINEER.
7. SIDEWALK BASE WILL BE VISUALLY INSPECTED FOR COMPACTION. CITY INSPECTOR CAN REQUIRE COMPACTION TESTING WHERE BASE ROCK COMPACTION IS VISUALLY OUT OF CONFORMANCE WITH SPECIFICATIONS 00640 / 00641.

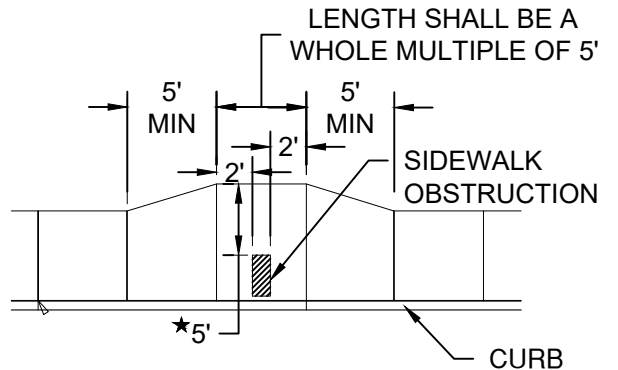

★ WHEN SITE CONSTRAINTS PROHIBIT A 5' PASSAGE, THE ENGINEER MAY DIRECT THIS TO BE REDUCED, BUT NO LESS THAN 4' REQUIRED SIDEWALK WIDENING AROUND OBSTRUCTIONS.

DRAWN AJD	
DIV ROADWAY	
REV	DATE
	ROADWAY



CITY OF BEND
STANDARD DRAWING
710 NW WALL ST., BEND, OREGON 97701

SHARED-USE PATH/SIDEWALK, CURB-TIGHT

SCALE NTS
DATE 04/16/2026
APPR
STD DWG R-4B

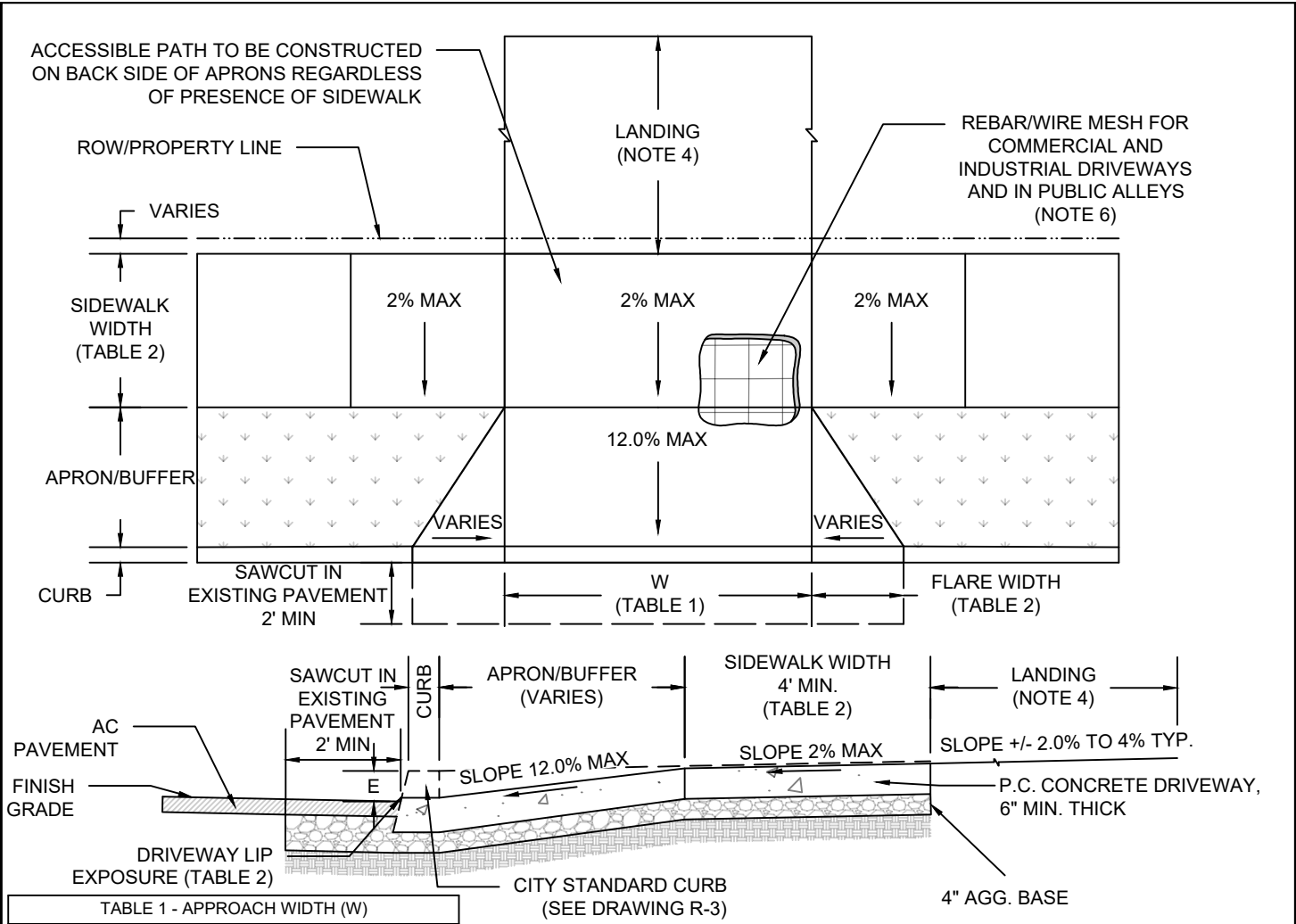

TABLE 1 - APPROACH WIDTH (W)

TYPE	WIDTH
RESIDENTIAL	10' - 24'
SINGLE FAMILY	10'-24'
TOWNHOME	32' MAX SHARED; 16' MAX LOCAL STREETS
DUPLEX	SUM 32' MAX (2 APRON MAX)
TRIPLEX	SUM 32' MAX (3 APRON MAX)
QUADPLEX	SUM 32' MAX (4 APRON MAX)
MULTIFAMILY	20' - 30'
COMMERCIAL	10' - 35'

**TYPICAL PLAN AND PROFILE VIEW
DRIVEWAY APPROACH, SETBACK SIDEWALK (STANDARD)**

TABLE 2 - DRIVEWAY APPROACH WITH SETBACK SIDEWALK SPECIFICATIONS

TYPE OF STREET	SIDEWALK WIDTH	LIP EXPOSURE	APRON GRADE, POSITIVE GRADE TO ROW	FLARE WIDTH
LOCAL	PER R-1D THRU R-1F	3/4"	12.0% MAX	3'
COLLECTOR	PER R-1B & R-1-C	1"	12.0% MAX	6'
ARTERIAL	PER R-1A	1"	12.0% MAX	6'

- GENERAL NOTES:**
- SIDEWALKS SHALL MEET ALL STANDARDS OF CURRENT PUBLIC RIGHTS OF WAY ACCESSIBILITY GUIDELINES (PROWAG).
 - CURB AND SIDEWALK TYPES VARY, SEE PLANS. SEE STD. DRG. R-3 FOR CURB DETAILS. SEE STD. DRGS. R-4A & R-4B FOR SIDEWALK DETAILS.
 - TOOLED JOINTS ARE REQUIRED AT ALL DRIVEWAY SLOPE BREAK LINES.
 - THE LANDING SHALL BE PAVED WITH CONCRETE OR ASPHALT SURFACE FOR A MINIMUM OF 20 FEET ON ALLEYS. LANDINGS ON PRIVATE LOTS SHALL BE IN ACCORDANCE WITH THE BEND DEVELOPMENT CODE. CONSTRUCT AS DIRECTED OR AS SHOWN ON PLANS. DO NOT ENTER PRIVATE PROPERTY WITHOUT APPROPRIATE PERMIT OR EASEMENT. MATERIAL WITHIN THE ROW SHALL BE CONCRETE.
 - CHECK THE GUTTER FLOW DEPTH AT DRIVEWAY LOCATIONS TO ASSURE THAT THE DESIGN FLOOD DOES NOT OVERTOP THE BACK OF SIDEWALK AT DRIVEWAY. IF OVERTOPPING OCCURS PLACE AN INLET AT UPSTREAM SIDE OF DRIVEWAY OR PERFORM OTHER APPROVED DESIGN MITIGATION.
 - #4 REBAR (20" ON CENTER, TO BE SUSPENDED TO CENTER OF CONCRETE DEPTH) REQUIRED IN COMMERCIAL AND INDUSTRIAL DRIVEWAYS AND IN PUBLIC ALLEYS. 6"x6" 10 GAUGE MINIMUM WELDED WIRE MAY BE USED IN LIEU OF REBAR.
 - CONCRETE DRIVEWAY APRON REQUIRED WHERE SIDEWALK AND/OR CURB IS EXISTING/PROPOSED, OTHERWISE AN ASPHALT APPROACH CAN BE INSTALLED TO EDGE OF PAVEMENT TO SIMILAR WIDTHS OF THE DRIVEWAY APRON AS APPROVED BY THE CITY ENGINEER.
 - REFER TO THE BEND DEVELOPMENT CODE 3.1.400 AND 3.6.200 FOR NUMBER AND WIDTH OF APRONS PERMITTED PER LOT.
 - THIS SAME STANDARD APPLIES TO ALLEYS
 - NO PAVERS OR HEATED SIDEWALKS/APRONS ARE PERMITTED WITHIN THE RIGHT OF WAY.

DRAWN AJD		<p align="center">CITY OF BEND</p> <p align="center">STANDARD DRAWING</p> <p align="center">710 NW WALL ST., BEND, OREGON 97701</p>	SCALE NTS
DIV ROADWAY			DATE 11/01/2024
REV DATE			APPR
<p align="center">DRIVEWAY APPROACH, SETBACK (STANDARD)</p>			STD DWG R-5A

ACCESSIBLE PATH TO BE CONSTRUCTED ON BACK SIDE OF APRONS REGARDLESS OF PRESENCE OF SIDEWALK

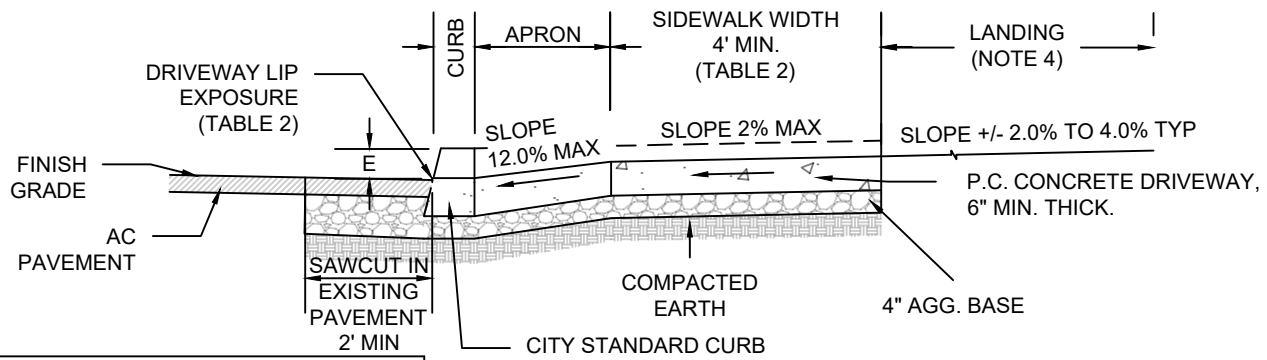
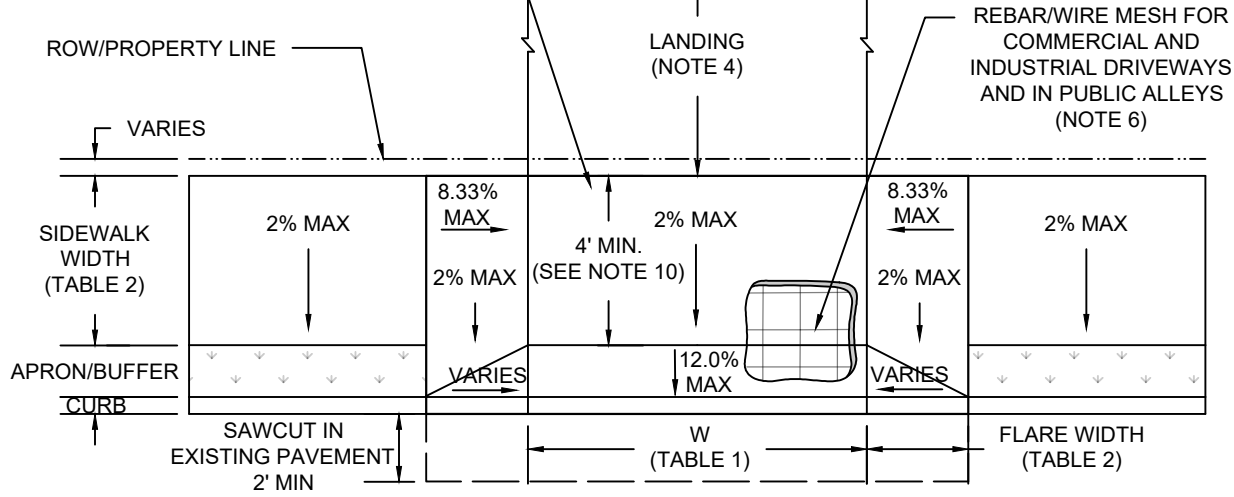

TYPE	WIDTH
RESIDENTIAL	10' - 24'
SINGLE FAMILY	10'-24'
TOWNHOME	32' MAX SHARED; 16' MAX LOCAL STREETS
DUPLEX	SUM 32' MAX (2 APRON MAX)
TRIPLEX	SUM 32' MAX (3 APRON MAX)
QUADPLEX	SUM 32' MAX (4 APRON MAX)
MULTIFAMILY	20' - 30'
COMMERCIAL	10' - 35'

**TYPICAL PLAN AND PROFILE VIEW
DRIVEWAY APPROACH, SETBACK, PARTIALLY LOWERED
(ALTERNATE B)**

TYPE OF STREET	SIDEWALK WIDTH	LIP EXPOSURE	APRON GRADE, POSITIVE GRADE TO ROW	FLARE WIDTH
LOCAL	PER R-1D THRU R-1F	3/4"	12.0% MAX	3'
COLLECTOR	PER R-1B & R-1-C	1"	12.0% MAX	6'
ARTERIAL	PER R-1A	1"	12.0% MAX	6'

- GENERAL NOTES:
- SIDEWALKS SHALL MEET ALL STANDARDS OF CURRENT PUBLIC RIGHTS OF WAY ACCESSIBILITY GUIDELINES (PROWAG).
 - CURB AND SIDEWALK TYPES VARY, SEE PLANS. SEE STD. DRG. R-3 FOR CURB DETAILS. SEE STD. DRGS. R-4A & R-4B FOR SIDEWALK DETAILS.
 - TOOLED JOINTS ARE REQUIRED AT ALL DRIVEWAY SLOPE BREAK LINES.
 - THE LANDING SHALL BE PAVED WITH CONCRETE OR ASPHALT SURFACE FOR A MINIMUM OF 20 FEET ON ALLEYS. LANDINGS ON PRIVATE LOTS SHALL BE IN ACCORDANCE WITH THE BEND DEVELOPMENT CODE. CONSTRUCT AS DIRECTED OR AS SHOWN ON PLANS. DO NOT ENTER PRIVATE PROPERTY WITHOUT APPROPRIATE PERMIT OR EASEMENT. MATERIAL WITHIN THE ROW SHALL BE CONCRETE.
 - CHECK THE GUTTER FLOW DEPTH AT DRIVEWAY LOCATIONS TO ASSURE THAT THE DESIGN FLOOD DOES NOT OVERTOP THE BACK OF SIDEWALK AT DRIVEWAY. IF OVERTOPPING OCCURS PLACE AN INLET AT UPSTREAM SIDE OF DRIVEWAY OR PERFORM OTHER APPROVED DESIGN MITIGATION.
 - #4 REBAR (2'0" ON CENTER, TO BE SUSPENDED TO CENTER OF CONCRETE DEPTH) REQUIRED IN COMMERCIAL AND INDUSTRIAL DRIVEWAYS AND IN PUBLIC ALLEYS. 6"x6" 10 GAUGE MINIMUM WELDED WIRE MAY BE USED IN LIEU OF REBAR.
 - CONCRETE DRIVEWAY APRON REQUIRED WHERE SIDEWALK AND/OR CURB IS EXISTING/PROPOSED, OTHERWISE AN ASPHALT APPROACH CAN BE INSTALLED TO EDGE OF PAVEMENT TO SIMILAR WIDTHS OF THE DRIVEWAY APRON AS APPROVED BY THE CITY ENGINEER.
 - REFER TO THE BEND DEVELOPMENT CODE 3.1.400 AND 3.6.200 FOR NUMBER AND WIDTH OF APRONS PERMITTED PER LOT.
 - THIS SAME STANDARD APPLIES TO ALLEYS
 - WHERE ON A LOW STRESS ROUTE, THE SIDEWALK/PATH WIDTH THROUGH THE DRIVEWAY APRON MUST BE MAINTAINED.
 - NO PAVERS OR HEATED SIDEWALKS/APRONS ARE PERMITTED WITHIN THE RIGHT OF WAY.

DRAWN	CJH
DIV	ROADWAY
REV	DATE



CITY OF BEND
STANDARD DRAWING
710 NW WALL ST., BEND, OREGON 97701

DRIVEWAY APPROACH, SETBACK, PARTIALLY LOWERED (ALTERNATE B)

SCALE	NTS
DATE	11/01/2024
APPR	
STD DWG	R-5B

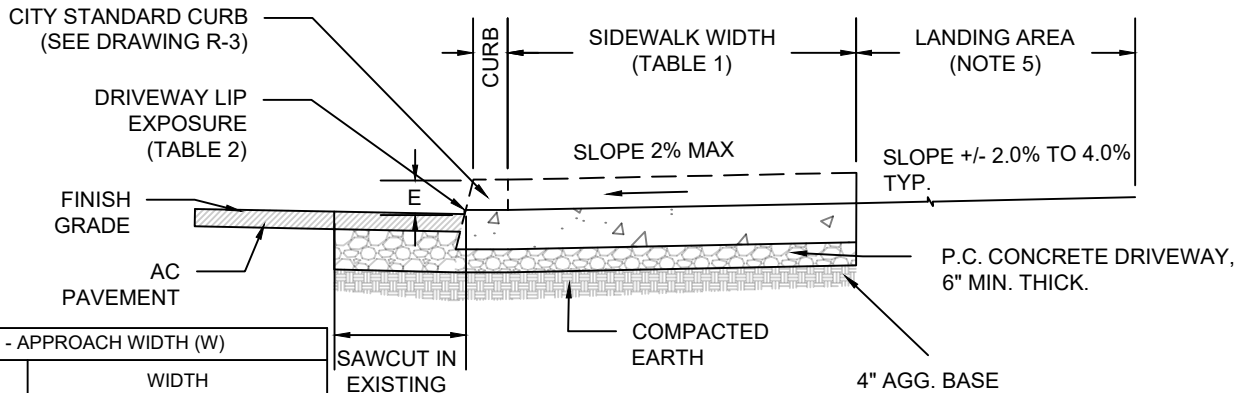
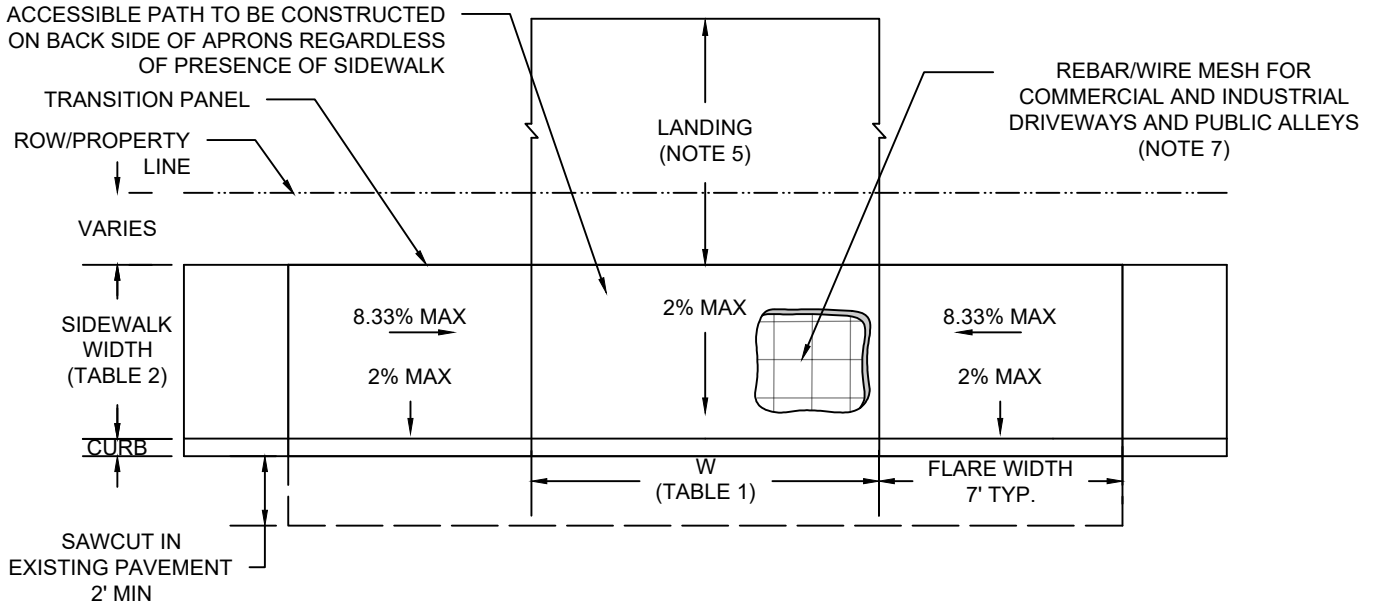

TYPE	WIDTH
RESIDENTIAL	10' - 24'
SINGLE FAMILY	10'-24'
TOWNHOME	32' MAX SHARED; 16' MAX LOCAL STREETS
DUPLEX	SUM 32' MAX (2 APRON MAX)
TRIPLEX	SUM 32' MAX (3 APRON MAX)
QUADPLEX	SUM 32' MAX (4 APRON MAX)
MULTIFAMILY	20' - 30'
COMMERCIAL	10' - 35'

TYPICAL PLAN AND PROFILE VIEW DRIVEWAY APPROACH, CURB-TIGHT, FULLY LOWERED (ALTERNATE C)

TYPE OF STREET	SIDEWALK WIDTH	LIP EXPOSURE	APRON GRADE, POSITIVE GRADE TO ROW	FLARE WIDTH
LOCAL	PER R-1D THRU R-1F	¾"	12.0% MAX	3'
COLLECTOR	PER R-1B & R1-C	1"	12.0% MAX	6'
ARTERIAL	PER R-1A	1"	12.0% MAX	6'

- GENERAL NOTES:**
- SIDEWALKS SHALL MEET ALL STANDARDS OF CURRENT PUBLIC RIGHTS OF WAY ACCESSIBILITY GUIDELINES (PROWAG).
 - CURB AND SIDEWALK TYPES VARY, SEE PLANS. SEE STD. DRG. R-3 FOR CURB DETAILS. SEE STD. DRGS. R-4A & R-4B FOR SIDEWALK DETAILS.
 - TOOLED JOINTS ARE REQUIRED AT ALL DRIVEWAY SLOPE BREAK LINES.
 - THE LANDING SHALL BE PAVED WITH CONCRETE OR ASPHALT SURFACE FOR A MINIMUM OF 20 FEET ON ALLEYS. LANDINGS ON PRIVATE LOTS SHALL BE IN ACCORDANCE WITH THE BEND DEVELOPMENT CODE. CONSTRUCT AS DIRECTED OR AS SHOWN ON PLANS. DO NOT ENTER PRIVATE PROPERTY WITHOUT APPROPRIATE PERMIT OR EASEMENT. MATERIAL WITHIN THE ROW SHALL BE CONCRETE.
 - CHECK THE GUTTER FLOW DEPTH AT DRIVEWAY LOCATIONS TO ASSURE THAT THE DESIGN FLOOD DOES NOT OVERTOP THE BACK OF SIDEWALK AT DRIVEWAY. IF OVERTOPPING OCCURS PLACE AN INLET AT UPSTREAM SIDE OF DRIVEWAY OR PERFORM OTHER APPROVED DESIGN MITIGATION.
 - #4 REBAR (20" ON CENTER, TO BE SUSPENDED TO CENTER OF CONCRETE DEPTH) REQUIRED IN COMMERCIAL AND INDUSTRIAL DRIVEWAYS AND IN PUBLIC ALLEYS. 6"x6" 10 GAUGE MINIMUM WELDED WIRE MAY BE USED IN LIEU OF REBAR.
 - CONCRETE DRIVEWAY APRON REQUIRED WHERE SIDEWALK AND/OR CURB IS EXISTING/PROPOSED, OTHERWISE AN ASPHALT APPROACH CAN BE INSTALLED TO EDGE OF PAVEMENT TO SIMILAR WIDTHS OF THE DRIVEWAY APRON AS APPROVED BY THE CITY ENGINEER.
 - REFER TO THE BEND DEVELOPMENT CODE 3.1.400 AND 3.6.200 FOR NUMBER AND WIDTH OF APRONS PERMITTED PER LOT.
 - THIS SAME STANDARD APPLIES TO ALLEYS
 - NO PAVERS OR HEATED SIDEWALKS/APRONS ARE PERMITTED WITHIN THE RIGHT OF WAY.

DRAWN A.JD DIV ROADWAY REV DATE		CITY OF BEND STANDARD DRAWING 710 NW WALL ST., BEND, OREGON 97701	SCALE NTS
CITY OF BEND			DATE 11/01/2024
		DRIVEWAY APPROACH, CURB-TIGHT, FULLY LOWERED (ALTERNATE C)	APPR
			STD DWG R-5C

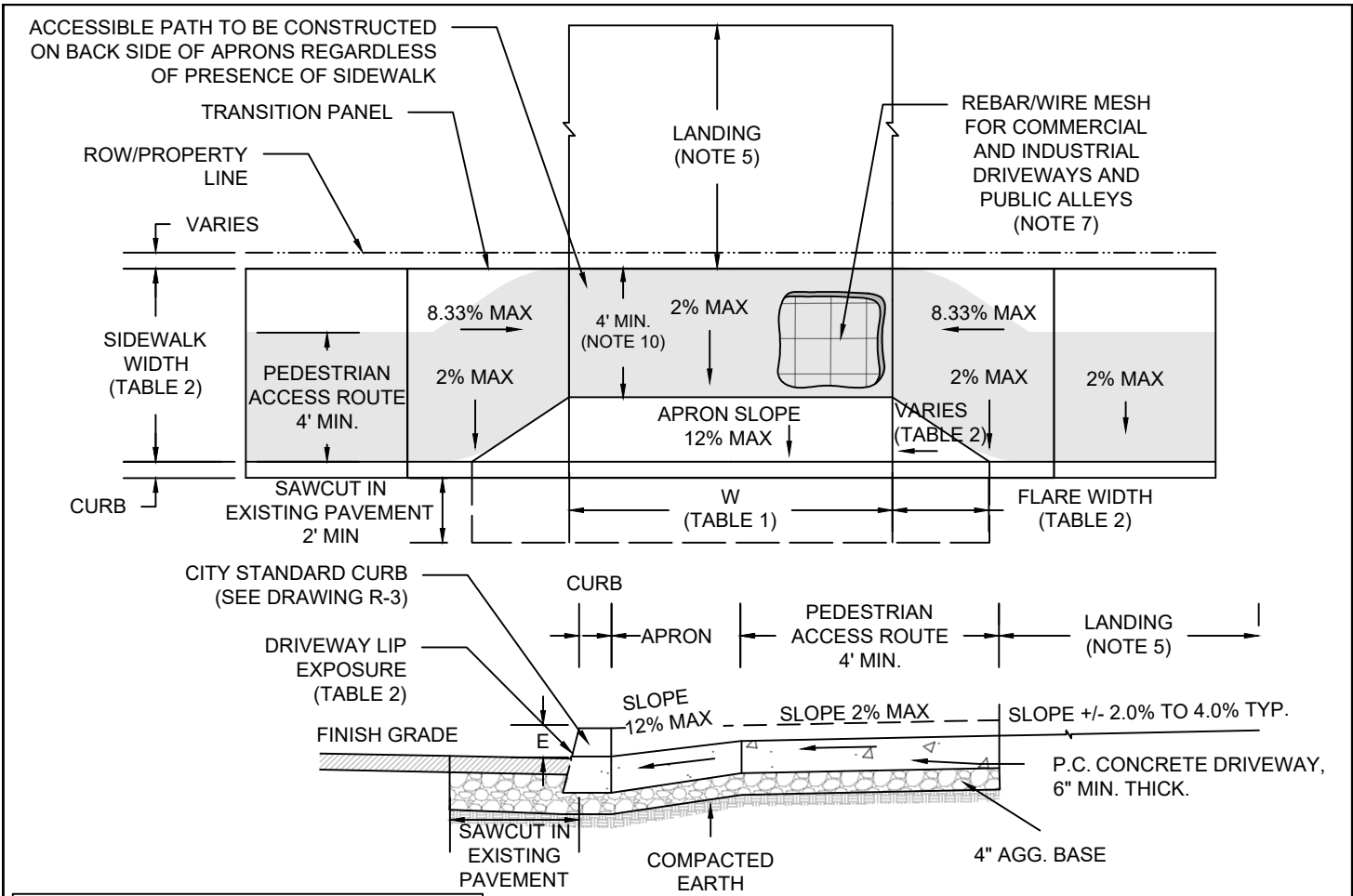

TABLE 1 - APPROACH WIDTH (W)

TYPE	WIDTH
RESIDENTIAL	10' - 24'
SINGLE FAMILY	10'-24'
TOWNHOME	32' MAX SHARED; 16' MAX LOCAL STREETS
DUPLEX	SUM 32' MAX (2 APRON MAX)
TRIPLEX	SUM 32' MAX (3 APRON MAX)
QUADPLEX	SUM 32' MAX (4 APRON MAX)
MULTIFAMILY	20' - 30'
COMMERCIAL	10' - 35'

**TYPICAL PLAN AND PROFILE VIEW
DRIVEWAY APPROACH, CURB-TIGHT, PARTIALLY LOWERED (ALTERNATE D)**

TABLE 2 - DRIVEWAY APPROACH WITH SETBACK SIDEWALK SPECIFICATIONS

TYPE OF STREET	SIDEWALK WIDTH	LIP EXPOSURE	APRON GRADE, POSITIVE GRADE TO ROW	FLARE WIDTH
LOCAL	PER R-1D THRU R-1F	3/4"	12.0% MAX	3'
COLLECTOR	PER R-1B & R1-C	1"	12.0% MAX	6'
ARTERIAL	PER R-1A	1"	12.0% MAX	6'

- GENERAL NOTES:**
- SIDEWALKS SHALL MEET ALL STANDARDS OF CURRENT PUBLIC RIGHTS OF WAY ACCESSIBILITY GUIDELINES (PROWAG).
 - CURB AND SIDEWALK TYPES VARY, SEE PLANS. SEE STD. DRG. R-3 FOR CURB DETAILS. SEE STD. DRGS. R-4A & R-4B FOR SIDEWALK DETAILS.
 - TOOLED JOINTS ARE REQUIRED AT ALL DRIVEWAY SLOPE BREAK LINES.
 - THE LANDING SHALL BE PAVED WITH CONCRETE OR ASPHALT SURFACE FOR A MINIMUM OF 20 FEET ON ALLEYS. LANDINGS ON PRIVATE LOTS SHALL BE IN ACCORDANCE WITH THE BEND DEVELOPMENT CODE. CONSTRUCT AS DIRECTED OR AS SHOWN ON PLANS. DO NOT ENTER PRIVATE PROPERTY WITHOUT APPROPRIATE PERMIT OR EASEMENT. MATERIAL WITHIN THE ROW SHALL BE CONCRETE.
 - CHECK THE GUTTER FLOW DEPTH AT DRIVEWAY LOCATIONS TO ASSURE THAT THE DESIGN FLOOD DOES NOT OVERTOP THE BACK OF SIDEWALK AT DRIVEWAY. IF OVERTOPPING OCCURS PLACE AN INLET AT UPSTREAM SIDE OF DRIVEWAY OR PERFORM OTHER APPROVED DESIGN MITIGATION.
 - #4 REBAR (2"0" ON CENTER, TO BE SUSPENDED TO CENTER OF CONCRETE DEPTH) REQUIRED IN COMMERCIAL AND INDUSTRIAL DRIVEWAYS AND IN PUBLIC ALLEYS. 6"x6" 10 GAUGE MINIMUM WELDED WIRE MAY BE USED IN LIEU OF REBAR.
 - CONCRETE DRIVEWAY APRON REQUIRED WHERE SIDEWALK AND/OR CURB IS EXISTING/PROPOSED, OTHERWISE AN ASPHALT APPROACH CAN BE INSTALLED TO EDGE OF PAVEMENT TO SIMILAR WIDTHS OF THE DRIVEWAY APRON AS APPROVED BY THE CITY ENGINEER.
 - REFER TO THE BEND DEVELOPMENT CODE 3.1.400 AND 3.6.200 FOR NUMBER AND WIDTH OF APRONS PERMITTED PER LOT.
 - THIS SAME STANDARD APPLIES TO ALLEYS
 - WHERE ON A LOW STRESS ROUTE, THE SIDEWALK/PATH WIDTH THROUGH THE DRIVEWAY APRON MUST BE MAINTAINED.
 - NO PAVERS OR HEATED SIDEWALKS/APRONS ARE PERMITTED WITHIN THE RIGHT OF WAY.

DRAWN AJD		<p align="center">CITY OF BEND STANDARD DRAWING 710 NW WALL ST., BEND, OREGON 97701</p>	SCALE NTS
DIV ROADWAY			DATE 11/01/2024
REV DATE			APPR
<p align="center">CITY OF BEND</p>		DRIVEWAY APPROACH, CURB-TIGHT, PARTIALLY LOWERED (ALTERNATE D)	STD DWG R-5D

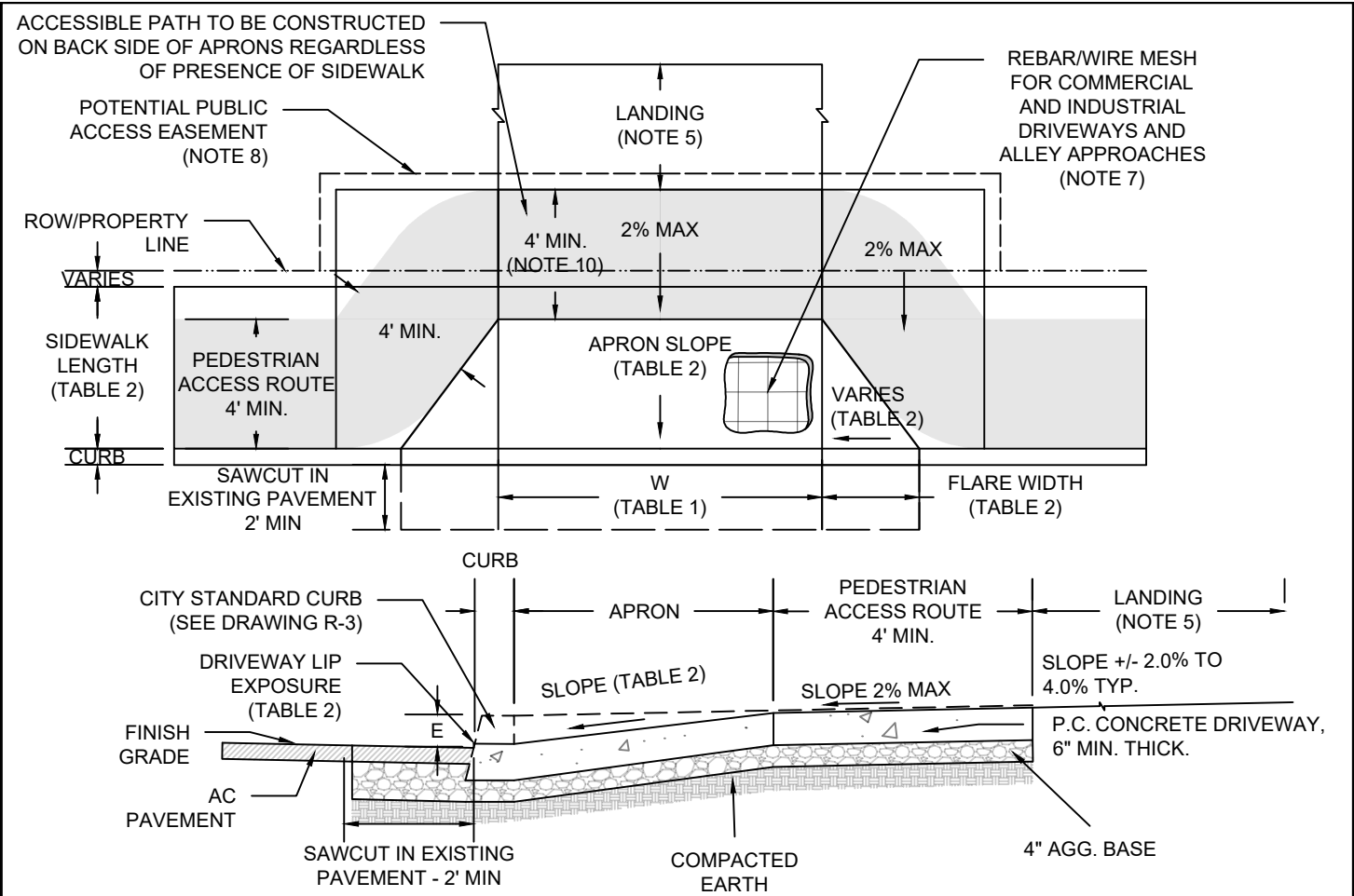

TABLE 1 - APPROACH WIDTH (W)

TYPE	WIDTH
RESIDENTIAL	10' - 24'
SINGLE FAMILY	10'-24'
TOWNHOME	32' MAX SHARED; 16' MAX LOCAL STREETS
DUPLEX	SUM 32' MAX (2 APRON MAX)
TRIPLEX	SUM 32' MAX (3 APRON MAX)
QUADPLEX	SUM 32' MAX (4 APRON MAX)
MULTIFAMILY	20' - 30'
COMMERCIAL	10' - 35'

**TYPICAL PLAN VIEW
DRIVEWAY APPROACH, CURB-TIGHT, WRAPPING SIDEWALK
(ALTERNATE E)**

TABLE 2 - DRIVEWAY APPROACH SPECIFICATIONS WITH CURB-TIGHT WRAPPING SIDEWALK

TYPE OF STREET	MINIMUM SIDEWALK WIDTH	LIP EXPOSURE	APRON GRADE, POSITIVE GRADE TO ROW	FLARE WIDTH
LOCAL	PER R-1D THRU R-1F	3/4"	12.0% MAX	3'
COLLECTOR	PER R-1B & R-1C	1"	12.5% MAX	6'
ARTERIAL	PER R-1A	1"	12.5% MAX	6'

- GENERAL NOTES:**
- SIDEWALKS SHALL MEET ALL STANDARDS OF CURRENT PUBLIC RIGHTS OF WAY ACCESSIBILITY GUIDELINES (PROWAG).
 - CURB AND SIDEWALK TYPES VARY, SEE PLANS. SEE STD. DRG. R-3 FOR CURB DETAILS. SEE STD. DRGS. R-4A & R-4B FOR SIDEWALK DETAILS.
 - TOOLED JOINTS ARE REQUIRED AT ALL DRIVEWAY SLOPE BREAK LINES.
 - THE LANDING SHALL BE PAVED WITH CONCRETE OR ASPHALT SURFACE FOR A MINIMUM OF 20 FEET ON ALLEYS. LANDINGS ON PRIVATE LOTS SHALL BE IN ACCORDANCE WITH THE BEND DEVELOPMENT CODE. CONSTRUCT AS DIRECTED OR AS SHOWN ON PLANS. DO NOT ENTER PRIVATE PROPERTY WITHOUT APPROPRIATE PERMIT OR EASEMENT. MATERIAL WITHIN THE ROW SHALL BE CONCRETE.
 - CHECK THE GUTTER FLOW DEPTH AT DRIVEWAY LOCATIONS TO ASSURE THAT THE DESIGN FLOOD DOES NOT OVERTOP THE BACK OF SIDEWALK AT DRIVEWAY. IF OVERTOPPING OCCURS PLACE AN INLET AT UPSTREAM SIDE OF DRIVEWAY OR PERFORM OTHER APPROVED DESIGN MITIGATION.
 - #4 REBAR (2'0" ON CENTER, TO BE SUSPENDED TO CENTER OF CONCRETE DEPTH) REQUIRED IN COMMERCIAL AND INDUSTRIAL DRIVEWAYS AND IN PUBLIC ALLEYS. 6"x6" 10 GAUGE MINIMUM WELDED WIRE MAY BE USED IN LIEU OF REBAR.
 - CONCRETE DRIVEWAY APRON REQUIRED WHERE SIDEWALK AND/OR CURB IS EXISTING/PROPOSED, OTHERWISE AN ASPHALT APPROACH CAN BE INSTALLED TO EDGE OF PAVEMENT TO SIMILAR WIDTHS OF THE DRIVEWAY APRON AS APPROVED BY THE CITY ENGINEER.
 - REFER TO THE BEND DEVELOPMENT CODE 3.1.400 AND 3.6.200 FOR NUMBER AND WIDTH OF APRONS PERMITTED PER LOT.
 - THIS SAME STANDARD APPLIES TO ALLEYS
 - WHERE ON A LOW STRESS ROUTE, THE SIDEWALK/PATH WIDTH THROUGH THE DRIVEWAY APRON MUST BE MAINTAINED.
 - NO PAVERS OR HEATED SIDEWALKS/APRONS ARE PERMITTED WITHIN THE RIGHT OF WAY.

DRAWN CJH DIV ROADWAY REV DATE		CITY OF BEND STANDARD DRAWING 710 NW WALL ST., BEND, OREGON 97701	SCALE NTS
CITY OF BEND			DATE 11/01/2024
		DRIVEWAY APPROACH, CURB-TIGHT, WRAPPING SIDEWALK (ALTERNATE E)	APPR
			STD DWG R-5E

TABLE 1 - APPROACH WIDTH (W) - REFER TO NOTE 4

TYPE	WIDTH
RESIDENTIAL	10' - 24'
SINGLE FAMILY	10'-24'
TOWNHOME	32' MAX SHARED; 16' MAX LOCAL STREETS
DUPLEX	SUM 32' MAX (2 APRON MAX)
TRIPLEX	SUM 32' MAX (3 APRON MAX)
QUADPLEX	SUM 32' MAX (4 APRON MAX)
MULTIFAMILY	20' - 30'
COMMERCIAL	10' - 35'

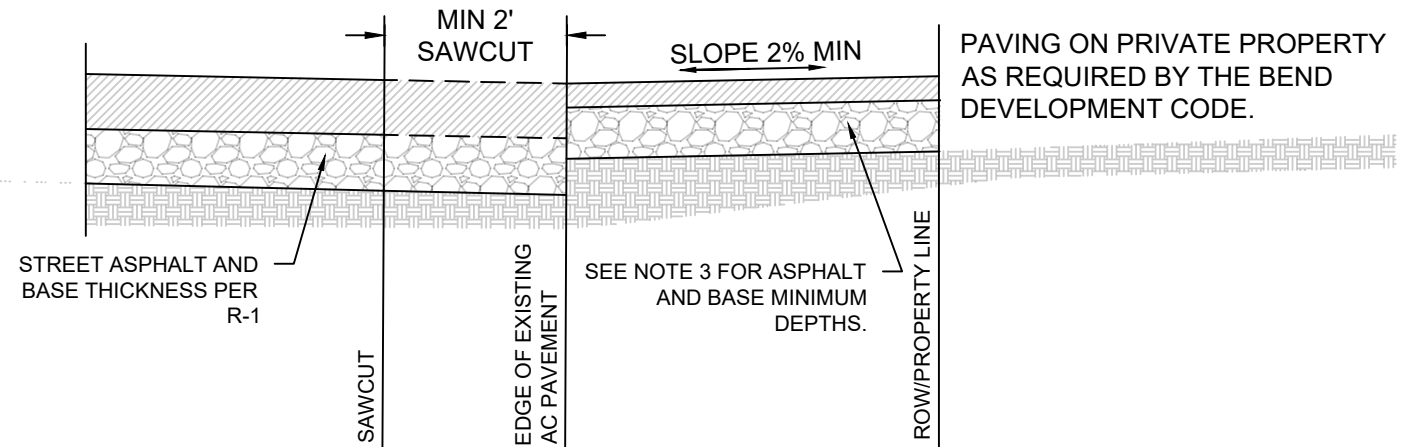
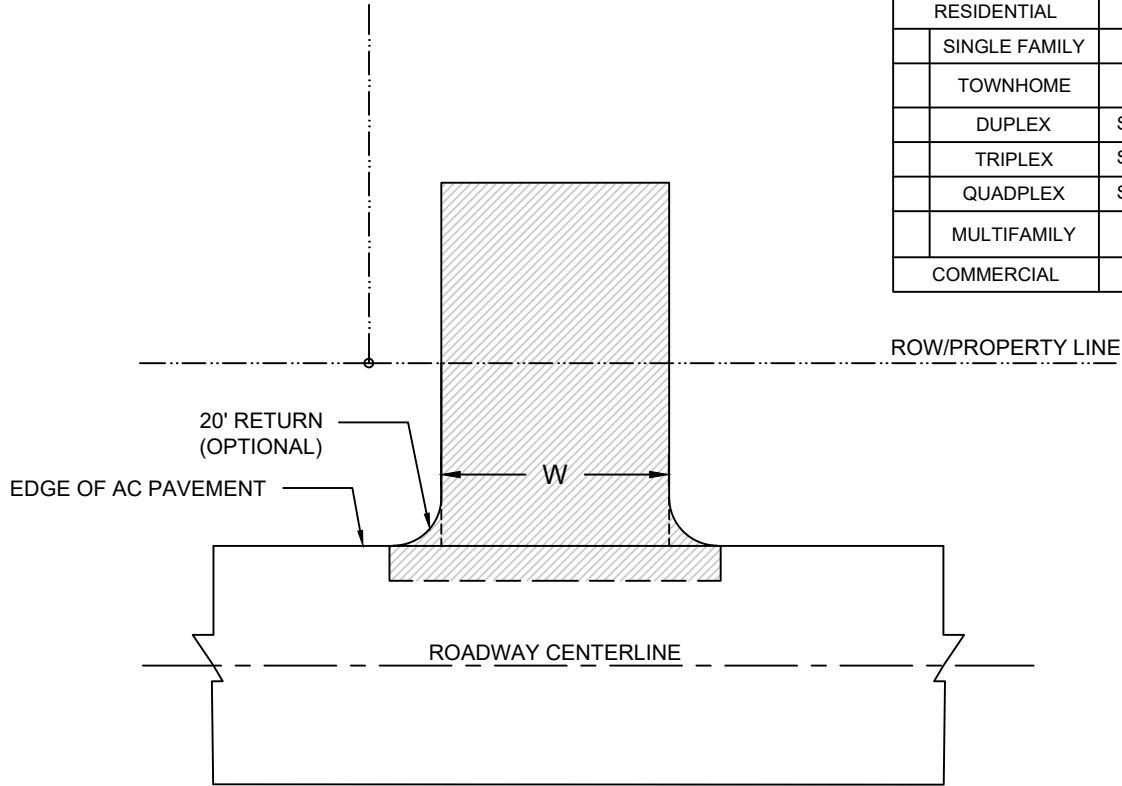

GENERAL NOTES:

1. CONCRETE DRIVEWAY APRONS REQUIRED WHERE SIDEWALK AND/OR CURB IS EXISTING OR PROPOSED, OTHERWISE AN ASPHALT APPROACH CAN BE INSTALLED TO EDGE OF PAVEMENT TO SIMILAR WIDTHS OF THE DRIVEWAY APRON AS APPROVED BY THE CITY ENGINEER.
2. NO PAVERS OR HEATED APRONS ARE PERMITTED WITHIN THE RIGHT OF WAY.
3. COMMERCIAL OR INDUSTRIAL USE MUST BE CONSTRUCTED TO A MINIMUM 4" ASPHALT OVER MINIMUM 6" BASE ROCK. RESIDENTIAL LOTS MUST HAVE NOT LESS THAN 2" ASPHALT OVER 4" BASED ROCK.
4. REFER TO THE BEND DEVELOPMENT CODE 3.1.400 AND 3.6.200 FOR NUMBER AND WIDTH OF APRONS PERMITTED PER LOT.

DRAWN CJH	
DIV ROADWAY	
REV	DATE



CITY OF BEND
 STANDARD DRAWING
 710 NW WALL ST., BEND, OREGON 97701
 DRIVEWAY APPROACH, ASPHALT

SCALE NTS
DATE 11/01/2024
APPR
STD DWG R-5F

GENERAL NOTES :

1. CITY OF BEND STD DWGS R-6, R-6A, R-6B, AND R-6C ARE INTENDED AS A SUMMARY OF PROWAG REQUIREMENTS. SEE CURRENT PROWAG GUIDELINES FOR COMPLETE REQUIREMENTS.
2. SLOPES USED FOR DESIGN ARE TYPICALLY LESS THAN THE MAXIMUMS TO ALLOW FOR CONSTRUCTION TOLERANCES. RECOMMENDED DESIGN SLOPES ARE AS FOLLOWS:

PROWAG MAX. SLOPE	DESIGN MAX. SLOPE
1:10 (10%)	9.5%
1:12 (8.33%)	7.5%
1:20 (5.0%)	4.5%
1:50 (2%)	1.5%

3. GRADE BREAKS ARE NOT PERMITTED ON THE SURFACE OF CURB RAMPS, BLENDED TRANSITIONS, LANDINGS, AND GUTTER AREAS WITHIN THE PEDESTRIAN ACCESS ROUTE.
4. THE COUNTER SLOPE OF THE GUTTER OR STREET AT THE FOOT OF A CURB RAMP, LANDING, OR BLENDED TRANSITION SHALL BE 5% MAXIMUM.
5. SURFACES OF CURB RAMPS, BLENDED TRANSITIONS, AND LANDINGS SHALL COMPLY WITH R302.7. GRATINGS, ACCESS COVERS, AND OTHER APPURTENANCES SHALL NOT BE LOCATED ON CURB RAMPS, LANDINGS, BLENDED TRANSITIONS AND GUTTERS WITHIN THE PEDESTRIAN ACCESS ROUTE.
6. SURFACE DISCONTINUITIES SHALL NOT EXCEED 0.5 in. MAXIMUM. VERTICAL DISCONTINUITIES BETWEEN 0.25 in. AND 0.5 in. MAXIMUM SHALL BE BEVELED AT 1:2 MINIMUM. THE BEVEL SHALL BE APPLIED ACROSS THE ENTIRE LEVEL CHANGE. SEE PROWAG R302.7.2.
7. WHERE SIDEWALKS ARE CONSTRUCTED OUTSIDE THE RIGHT OF WAY, A PUBLIC ACCESS EASEMENT MUST BE RECORDED OVER THE PRIVATE PROPERTY ENCROACHMENT.
8. 6 INCHES OF COMMERCIAL GRADE CONCRETE PER CITY SPEC 00440 AND 4 INCHES OF STATE SPEC AGGREGATE PER CITY SPEC 00640/00641 IS REQUIRED FOR CONSTRUCTION OF CURB RAMPS, FLARES, AND LANDINGS.
9. DETECTABLE WARNING SURFACES COMPLYING WITH PROWAG R305 SHALL BE PROVIDED, WHERE A CURB RAMP, LANDING, OR BLENDED TRANSITION CONNECTS TO A STREET.
10. DETECTABLE WARNING SURFACES SHALL EXTEND 24 in. MINIMUM IN THE DIRECTION OF TRAVEL AND THE FULL WIDTH OF THE CURB RAMP (EXCLUSIVE OF FLARES), THE LANDING, OR THE BLENDED TRANSITION.
11. THE ROWS OF TRUNCATED DOMES IN A DETECTABLE WARNING SURFACE SHALL BE ALIGNED TO BE PERPENDICULAR OR RADIAL TO THE GRADE BREAK BETWEEN THE RAMP, LANDING, OR BLENDED TRANSITION AND THE STREET.
12. THE CLEAR WIDTH OF LANDINGS BLENDED TRANSITIONS, AND CURB RAMPS, EXCLUDING FLARES, SHALL BE 4.0 FT. MINIMUM.

DRAWN AJD	
DIV ROADWAY	
REV	DATE



CITY OF BEND
 STANDARD DRAWING
 710 NW WALL ST., BEND, OREGON 97701

CURB RAMP GENERAL NOTES

SCALE NTS
DATE 01/31/2022
APPR
STD DWG R-6

CURB EXPOSURE TO BE MINIMUM 3-INCHES (6-INCH PREFERRED) BETWEEN RAMPS UNLESS OTHERWISE APPROVED.

GRADE BREAKS AT THE TOP AND BOTTOM OF PERPENDICULAR CURB RAMPS SHALL BE PERPENDICULAR TO THE DIRECTION OF RAMP RUN. AT LEAST ONE END OF THE BOTTOM GRADE BREAK SHALL BE AT THE BACK OF CURB. THE GRADE FROM THE BOTTOM OF THE DETECTABLE WARNING TO THE LANDING SHALL BE A CONTINUOUS GRADE (5% MAXIMUM). SURFACE SLOPES THAT MEET THE GRADE BREAKS SHALL BE FLUSH.

FLARED SIDES ARE PREFERRED, PARTICULARLY WHERE SUBJECT TO DAMAGE FROM ONCOMING TRAFFIC AND SNOWPLOWS. IF ADJACENT CONSTRAINTS PREVENT FLARE CONSTRUCTION, SIDE OF RAMPS MAY BE RETURNED IF PROTECTED FROM CROSS TRAVEL BY LANDSCAPING, STREET FURNITURE, POLES, OR EQUIPMENT.

ONE CORNER OF THE DETECTABLE WARNING MUST BE WITHIN 2 in. OF THE GRADE BREAK; NO OTHER POINT ON THE LEADING EDGE OF THE DETECTABLE WARNING MAY BE MORE THAN 5 ft. FROM THE BACK OF CURB.

WHERE BOTH ENDS OF THE BOTTOM GRADE BREAK, COMPLYING WITH PROWAG R305.2.1, ARE 5.0 ft. OR LESS FROM THE BACK OF CURB, THE DETECTABLE WARNING SHALL BE LOCATED ON THE RAMP SURFACE AT THE BOTTOM GRADE BREAK. WHERE EITHER END OF THE BOTTOM GRADE BREAK IS MORE THAN 5.0 ft. FROM THE BACK OF CURB, THE DETECTABLE WARNING SHALL BE LOCATED ON THE LOWER LANDING.

FLARED SIDES WITH A SLOPE OF 10% MAXIMUM, MEASURED PARALLEL TO THE CURB LINE, SHALL BE PROVIDED WHERE A PEDESTRIAN CIRCULATION PATH CROSSES THE CURB RAMP OR WHEN THE FLARE ABUTS A HARD SURFACE.

FLARES REQUIRED UNLESS BARRIERS EXIST OR WHERE APPROVED BY THE CITY ENGINEER. FLARE SLOPE CAN EXCEED 10% WHERE ABUTTING MIN 2' LANDSCAPING AREA.

A LANDING 5.0 ft. MINIMUM BY 5.0 ft. MINIMUM SHALL BE PROVIDED AT THE TOP OF THE CURB RAMP AND SHALL BE PERMITTED TO OVERLAP OTHER LANDINGS AND CLEAR SPACE. RUNNING AND CROSS SLOPES AT INTERSECTIONS SHALL BE 2% MAXIMUM.

PERPENDICULAR CURB RAMPS

THE RUNNING SLOPE SHALL BE 5% MINIMUM AND 8.3% MAXIMUM BUT SHALL NOT REQUIRE THE RAMP LENGTH TO EXCEED 15.0 FT.

BLENDED TRANSITIONS SHALL COMPLY WITH R303.3. RUNNING SLOPE SHALL BE 5% MAXIMUM AND CROSS SLOPE SHALL BE 2% MAXIMUM.

THE RAMP CROSS SLOPE SHALL NOT EXCEED 2% AT YIELD OR STOP CONTROLLED INTERSECTIONS. AT UNCONTROLLED INTERSECTIONS, THE CROSS SLOPE MAY TRANSITION FROM 2% AT THE LANDING UP TO 5% AT THE CURB. AT MIDBLOCK CROSSINGS, THE CROSS SLOPE MAY TRANSITION TO MATCH THE ROAD GRADE.

WIDTH OF RAMP TO MATCH SUP/SIDEWALK STANDARD WIDTH FOR ROAD CROSS-SECTION; ALTERNATE MAY BE APPROVED BY CITY ENGINEER IN EXISTING NON-COMPLIANT AREAS WITH NO PLANS FOR SIDEWALK UPGRADES.

TRANSITION PANEL FROM RAMP TO EXISTING SIDEWALK (WHERE REQUIRED TO MATCH EX. SIDEWALK CROSS SLOPE). MAX. GRADES ARE NOT SPECIFIED BY PROWAG. ADJUST LENGTH AS NEEDED TO PROVIDE 0.5% CHANGE PER FT. IF PROPOSED MATCH LINE LOCATION FALLS WITHIN 2 FEET FROM AN EXISTING JOINT IN THE SECTION OF SIDEWALK TO REMAIN, THE EXISTING WALK SHALL BE REMOVED BACK TO THE NEXT JOINT.

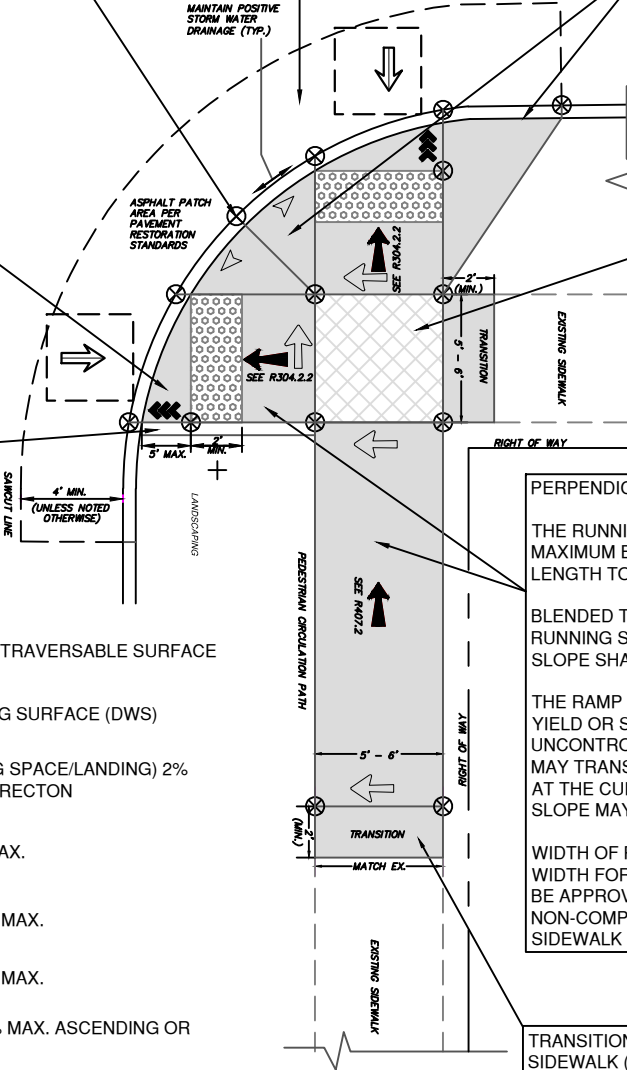

- SIDEWALK OR OTHER TRAVERSABLE SURFACE
- DETECTABLE WARNING SURFACE (DWS)
- LEVEL AREA (TURNING SPACE/LANDING) 2% MAX. SLOPE IN ANY DIRECTION
- CROSS SLOPE 2.0% MAX.
- RUNNING SLOPE 5.0% MAX.
- RUNNING SLOPE 8.3% MAX.
- COUNTER SLOPE 5.0% MAX. ASCENDING OR DESCENDING
- FLARE SLOPE 10% MAX.
- 4'X4' CLEAR SPACE
- REQUIRED DESIGN ELEVATIONS SLOPES TO BE SHOWN WITH DESIGN

TYPICAL PERPENDICULAR CURB RAMP
ACCORDING TO PROWAG REQUIREMENTS
NOT TO SCALE - ROTATED TO FIT

DRAWN	AJD
DIV	ROADWAY
REV	DATE



CITY OF BEND
STANDARD DRAWING

710 NW WALL ST., BEND, OREGON 97701

TYPICAL PERPENDICULAR CURB RAMP

SCALE	NTS
DATE	01/31/2022
APPR	
STD DWG	R-6A

TRANSITION PANEL FROM RAMP TO EXISTING SIDEWALK (WHERE REQUIRED TO MATCH EX. SIDEWALK CROSS SLOPE). MAX. GRADES ARE NOT SPECIFIED BY PROWAG. ADJUST LENGTH AS NEEDED TO PROVIDE SMOOTH TRANSITION. IF PROPOSED MATCH LINE LOCATION FALLS WITHIN 2 FEET FROM AN EXISTING JOINT IN THE SECTION OF SIDEWALK TO REMAIN, THE EXISTING WALK SHALL BE REMOVED BACK TO THE NEXT JOINT.

GRADE BREAKS AT THE TOP AND BOTTOM OF PARALLEL CURB RAMPS SHALL BE PERPENDICULAR TO THE DIRECTION OF RAMP RUN. SURFACE SLOPES THAT MEET THE GRADE BREAKS SHALL BE FLUSH.

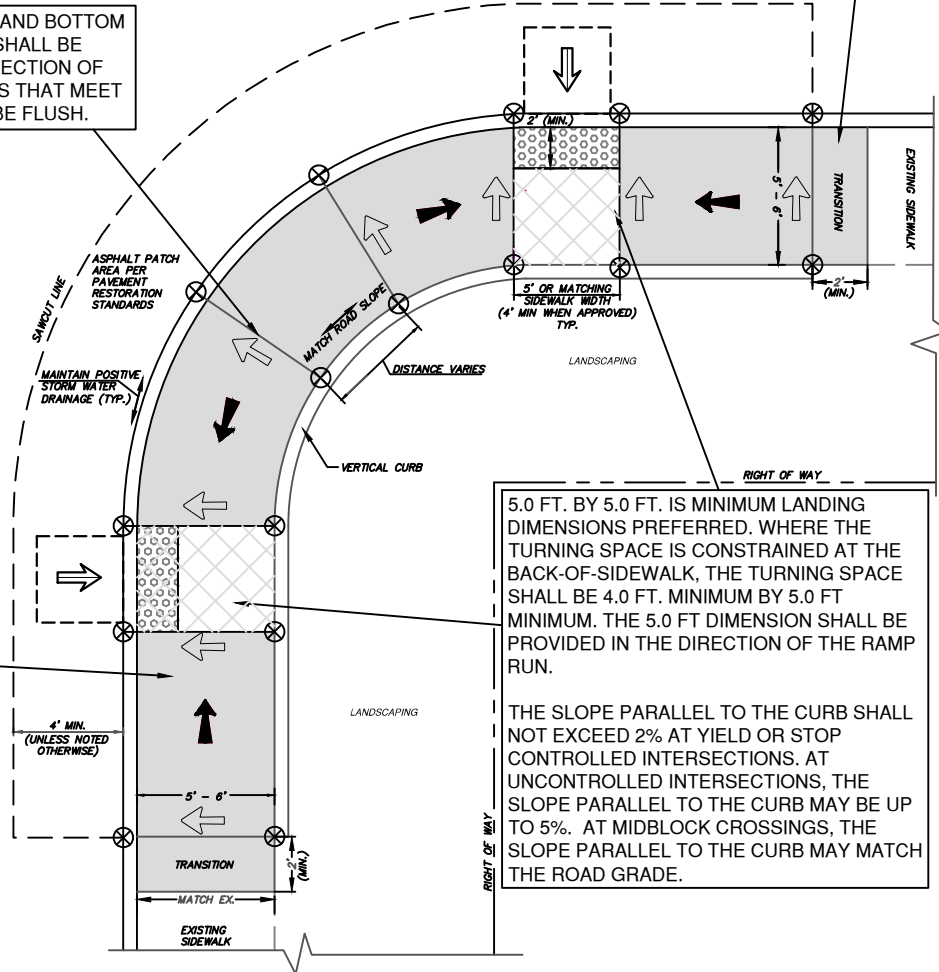

PARALLEL CURB RAMPS

THE RUNNING SLOPE SHALL BE 8.33% MAXIMUM BUT SHALL NOT REQUIRE THE RAMP LENGTH TO EXCEED 15.0 FT.

THE CROSS SLOPE SHALL BE 2% MAXIMUM.







THE CLEAR WIDTH OF LANDINGS BLENDED TRANSITIONS, AND CURB RAMPS, EXCLUDING FLARES, SHALL BE 4.0 FT. MINIMUM.

LANDING WIDTH SHALL MATCH THE ADJACENT SIDEWALK WIDTH, 5.0 FT MIN., UNLESS OTHERWISE APPROVED.

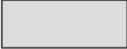
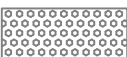
5.0 FT. BY 5.0 FT. IS MINIMUM LANDING DIMENSIONS PREFERRED. WHERE THE TURNING SPACE IS CONSTRAINED AT THE BACK-OF-SIDEWALK, THE TURNING SPACE SHALL BE 4.0 FT. MINIMUM BY 5.0 FT MINIMUM. THE 5.0 FT DIMENSION SHALL BE PROVIDED IN THE DIRECTION OF THE RAMP RUN.

THE SLOPE PARALLEL TO THE CURB SHALL NOT EXCEED 2% AT YIELD OR STOP CONTROLLED INTERSECTIONS. AT UNCONTROLLED INTERSECTIONS, THE SLOPE PARALLEL TO THE CURB MAY BE UP TO 5%. AT MIDBLOCK CROSSINGS, THE SLOPE PARALLEL TO THE CURB MAY MATCH THE ROAD GRADE.

TYPICAL PARALLEL CURB RAMP
ACCORDING TO PROWAG REQUIREMENTS
NOT TO SCALE - ROTATED TO FIT

-  SIDEWALK OR OTHER TRAVERSABLE SURFACE
-  DETECTABLE WARNING SURFACE (DWS)
-  LEVEL AREA (TURNING SPACE/LANDING)
2% MAX. SLOPE IN ANY DIRECTION
-  CROSS SLOPE 2.0% MAX.
-  RUNNING SLOPE 8.3% MAX.
-  COUNTER SLOPE 5.0% MAX. ASCENDING OR DESCENDING
-  4'X4' CLEAR SPACE
-  REQUIRED DESIGN ELEVATIONS
SLOPES TO BE SHOWN WITH DESIGN

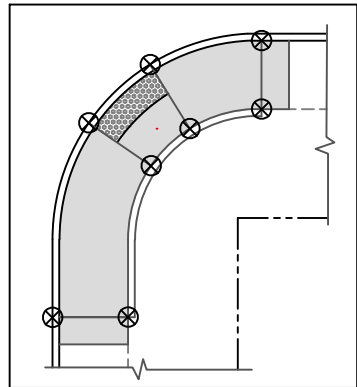

TYPICAL DIAGONAL CURB RAMP
REQUIRES CITY APPROVAL FOR CONSTRUCTION
ACCORDING TO PROWAG REQUIREMENTS
NOT TO SCALE - ROTATED TO FIT

NOTE: DIAGONAL CURB RAMP ALTERNATE IS ONLY ALLOWED WHEN DIRECTIONAL RAMPS ARE NOT POSSIBLE AND MUST BE APPROVED BY THE CITY ENGINEER.

DRAWN	AJD
DIV	ROADWAY
REV	DATE



CITY OF BEND
STANDARD DRAWING
710 NW WALL ST., BEND, OREGON 97701

TYPICAL PARALLEL CURB RAMP

SCALE	NTS
DATE	01/31/2022
APPR	
STD DWG	R-6B

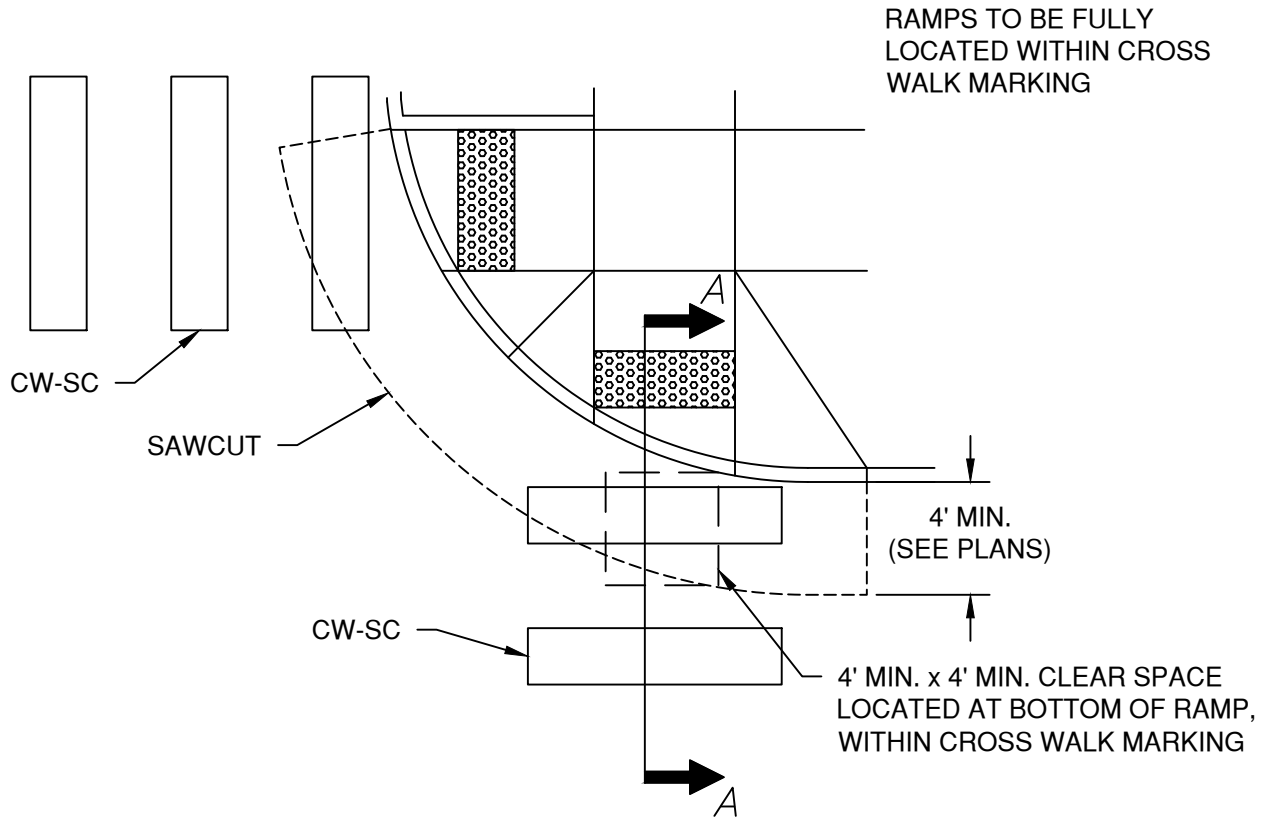

CROSS WALK - CURB RAMP ORIENTATION
NOT TO SCALE

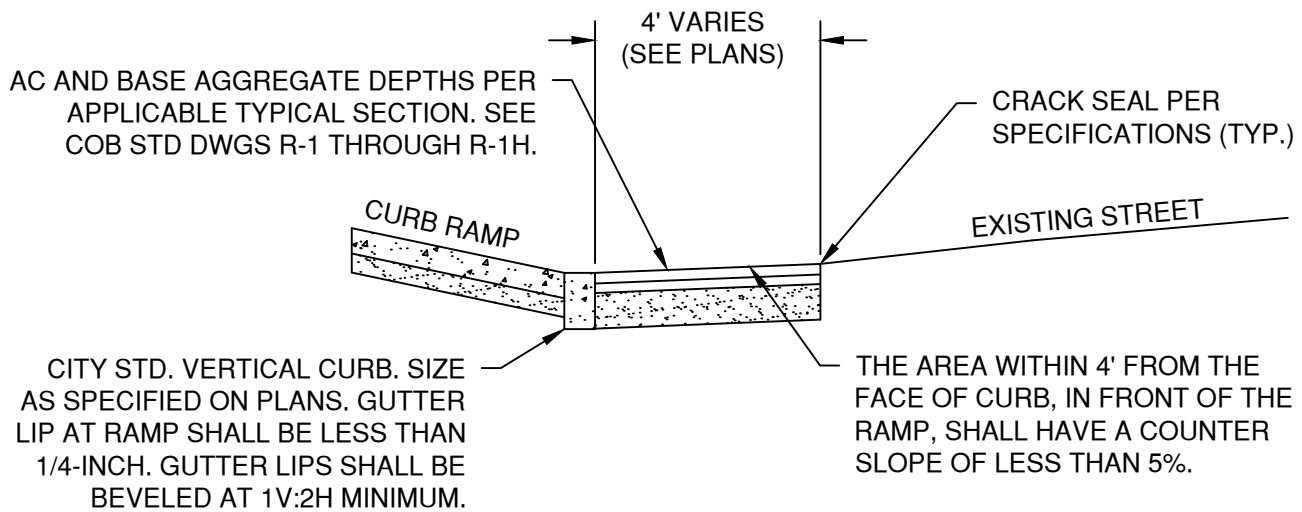

NOTE: IN AREAS WITH UNIT PAVER CROSS WALKS, REMOVE EXISTING PAVERS, AND RE-INSTALL AT GRADES TO ACHIEVE THESE REQUIREMENTS.

TYPICAL RAMP / ASPHALT PATCH SECTION
NOT TO SCALE

DRAWN ARI	
DIV ROADWAY	
REV	DATE



CITY OF BEND
 STANDARD DRAWING
 710 NW WALL ST., BEND, OREGON 97701

CURB RAMP DETAILS

SCALE NTS
DATE 04/16/2026
APPR
STD DWG R-6C

INSTALLATION IN NEW CONSTRUCTION

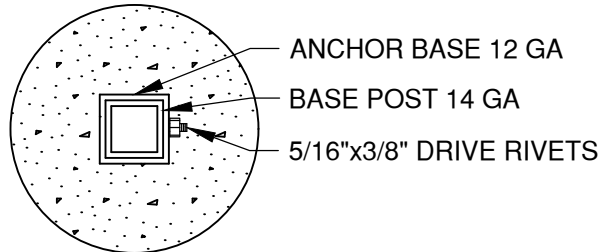

SECTION A-A

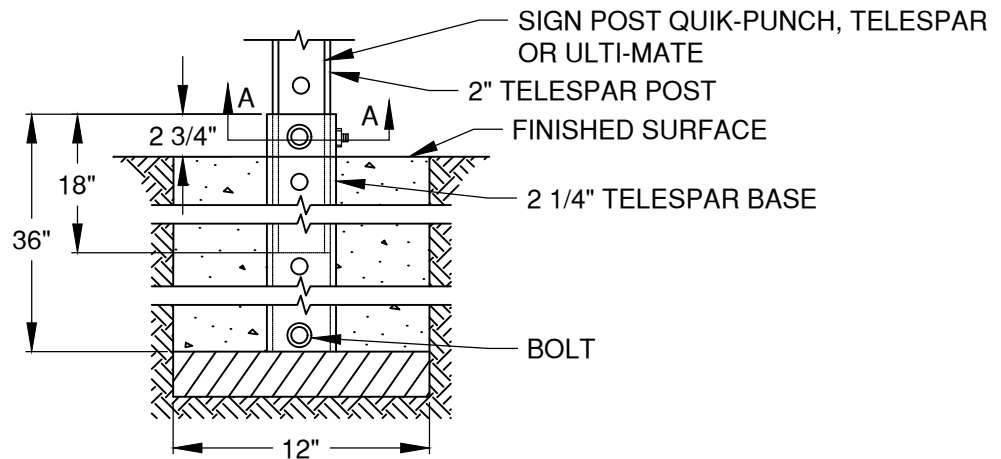

ANCHOR BASE DETAIL

NOTES:

1. USE PSST ANCHOR BASE FOUNDATION FOR ALL SIGN LOCATIONS OTHER THAN IN MEDIANS AND ROUNDABOUT SPLITTER ISLANDS PER STD DWG R-7A.
2. ANCHOR BASE HOLES AND BOTTOM OF ANCHOR BASE SHALL BE COVERED SO THAT CONCRETE DOES NOT SEEP INTO ANCHOR BASE DURING SETTING
3. BASE SHOULD BE SET SEPARATELY FROM POST WITH ANCHOR BOLT IN BASE BOTTOM ONLY
4. POST SHOULD BE ABLE TO SLIDE FREELY WHEN RIVET IS REMOVED
5. FOR LARGE SIGNS THAT EXCEED WINDLOADS 2 1/2" POSTS MAY BE APPROVED BY CITY ENGINEER

DRAWN AJD DIV ROADWAY REV DATE	 CITY OF BEND	CITY OF BEND STANDARD DRAWING <small>710 NW WALL ST., BEND, OREGON 97701</small>	SCALE NTS DATE 01/31/2022 APPR STD DWG R-7
		PSST ANCHOR BASE FOUNDATION	

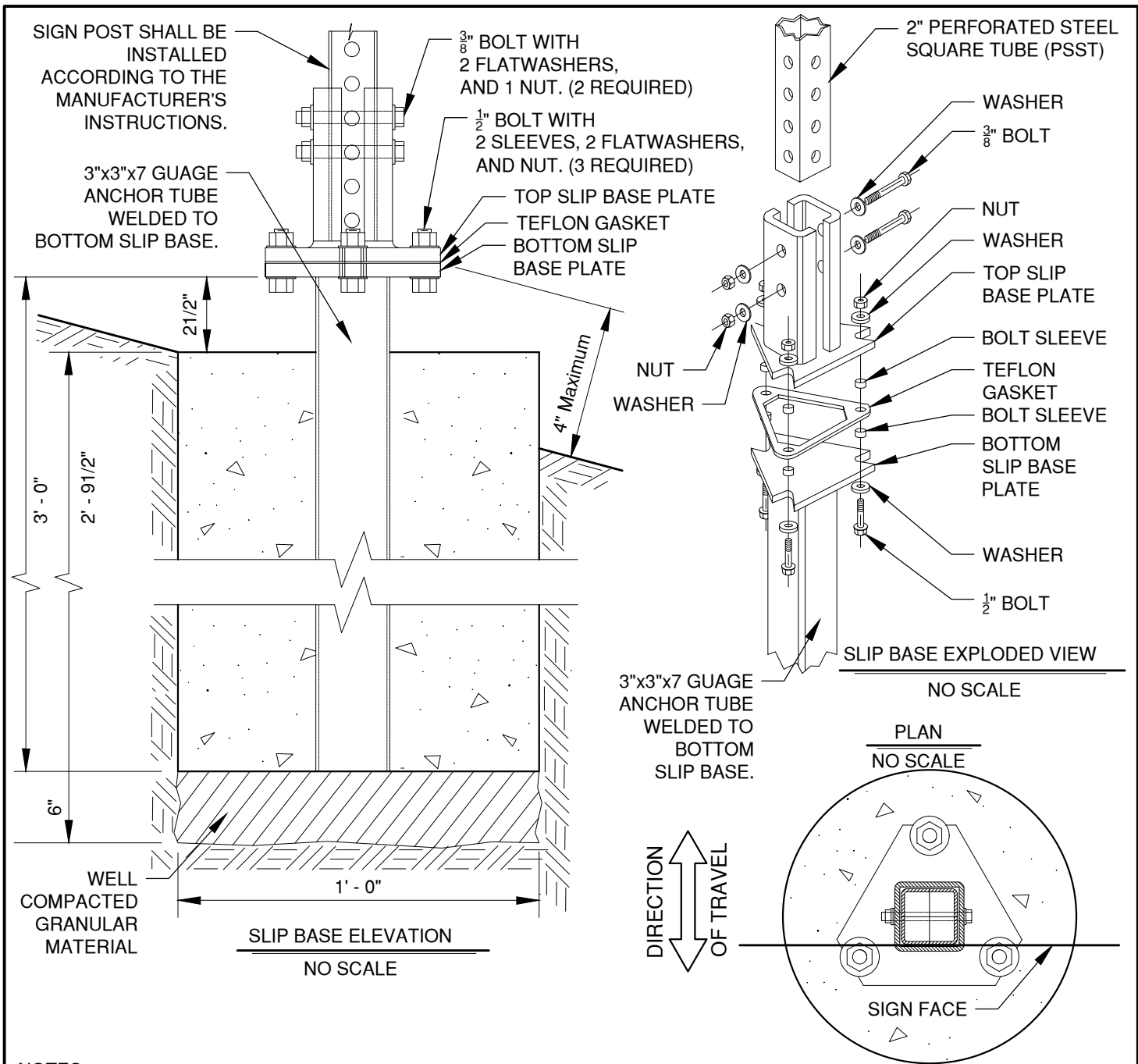

NOTES:

1. USE PSST SLIP BASE FOUNDATION FOR SIGNS INSTALLED IN MEDIANS AND ROUNDABOUT SPLITTER ISLANDS.
2. MATERIAL GRADE FOR BASE HARDWARE CONNECTION SHALL BE ACCORDING TO THE MANUFACTURER'S RECOMMENDATION AND BASED ON CRASH TESTING.
3. SLIP BASE STEEL SHALL BE HOT DIPPED GALVANIZED OR APPROVAL EQUAL.
4. FOOTING CONCRETE SHALL BE COMMERCIAL GRADE CONCRETE (FC=3000PSI) PER SPECIFICATION 00440. THE CGC MIXTURE MAY BE ACCEPTED AT THE SITE OF PLACEMENT ACCORDING TO 00440.14.
5. ALL SLIP BASES SHALL BE PRE-ASSEMBLED BY THE MANUFACTURER AND SHALL BE INSTALLED ACCORDING TO THE MANUFACTURER'S INSTRUCTIONS.
6. SLIP BASE DETAILS SHOWN ARE NOT FOR A SPECIFIC MANUFACTURER AND ARE ONLY SHOWN TO CONVEY GENERAL PIECES OF A SLIP BASE SYSTEM. SPECIFIC SLIP BASE MATERIAL WILL BE ACCORDING TO THE MANUFACTURER'S DOCUMENTATION.
7. FOR LARGE SIGNS THAT EXCEED WINDLOADS, 2 1/2" PSST MAY BE APPROVED BY CITY ENGINEER

DRAWN AJD DIV ROADWAY REV DATE	 CITY OF BEND	CITY OF BEND STANDARD DRAWING 710 NW WALL ST., BEND, OREGON 97701	SCALE NTS
PSST SLIP BASE FOUNDATION			DATE 01/31/2022
			APPR
			STD DWG R-7A

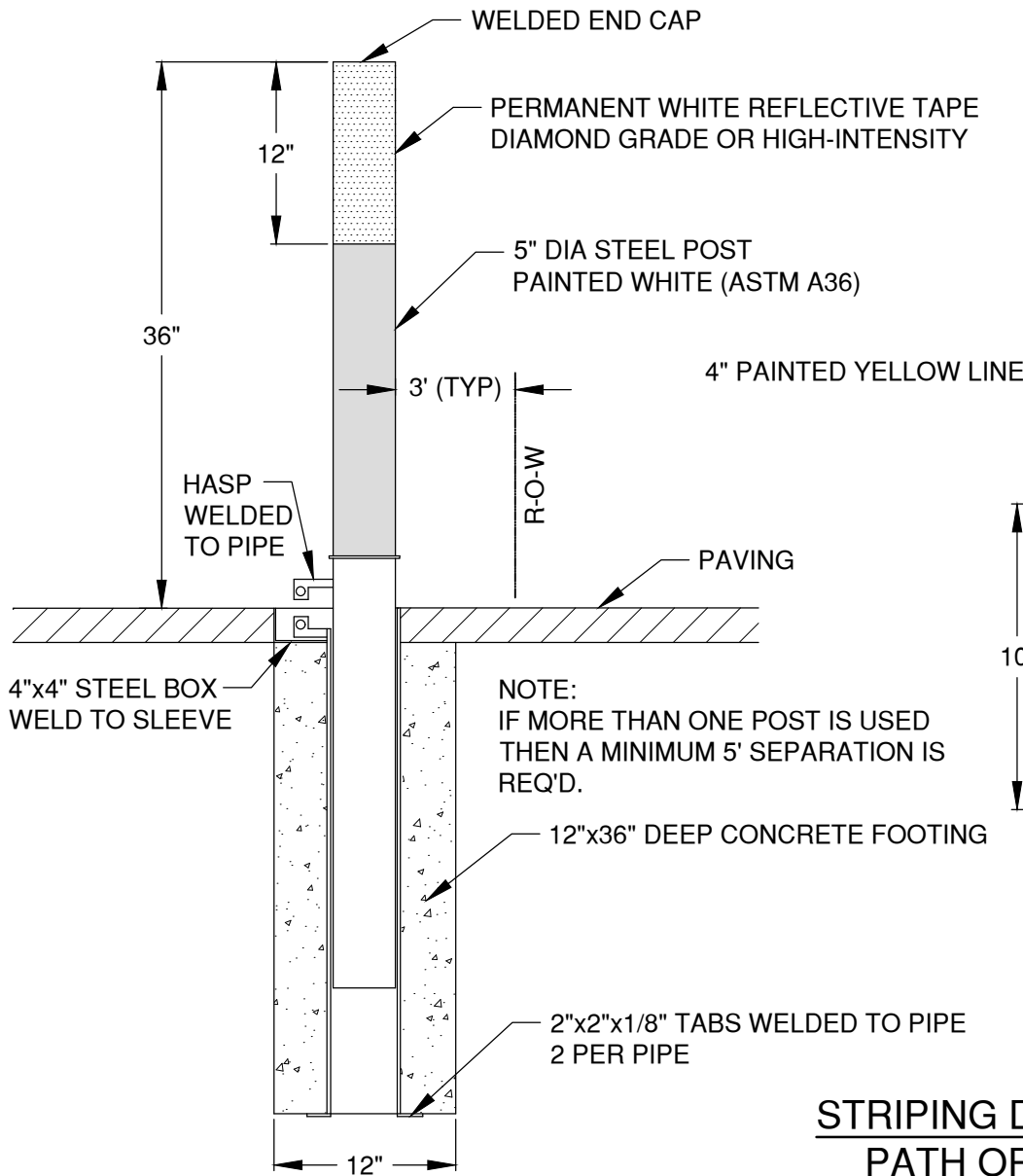

NOTE:
IF MORE THAN ONE POST IS USED
THEN A MINIMUM 5' SEPARATION IS
REQ'D.

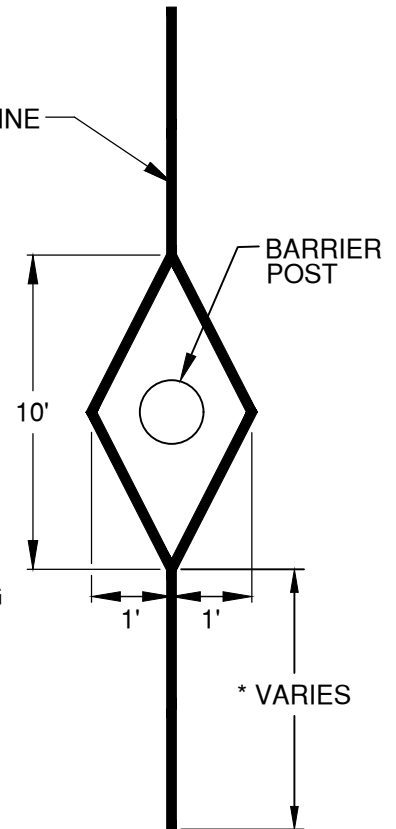

**STRIPING DETAIL FOR PAVED
PATH OR ACCESS ROAD**

* Length of approach line varies by location, where possible, 25' min.

NOTES:

1. POSTS OR BOLLARDS SHALL BE SET BACK BEYOND THE CLEAR ZONE OF THE ADJACENT STREET OR BE OF A BREAKAWAY DESIGN. THE POST SHALL BE PERMANENTLY REFLECTORIZED FOR NIGHTTIME VISIBILITY AND PAINTED WHITE FOR IMPROVED DAYTIME AND NIGHT TIME VISIBILITY.
2. ON PAVED PATHS OR ACCESS ROADS, APPLY PAVEMENT MARKINGS PER STRIPING DETAIL.

DRAWN AJD	
DIV ROADWAY	
REV	DATE



CITY OF BEND

CITY OF BEND

STANDARD DRAWING

710 NW WALL ST., BEND, OREGON 97701

REMOVABLE POST AND MARKINGS

SCALE NTS

DATE 01/31/2022

APPR

STD DWG R-7B

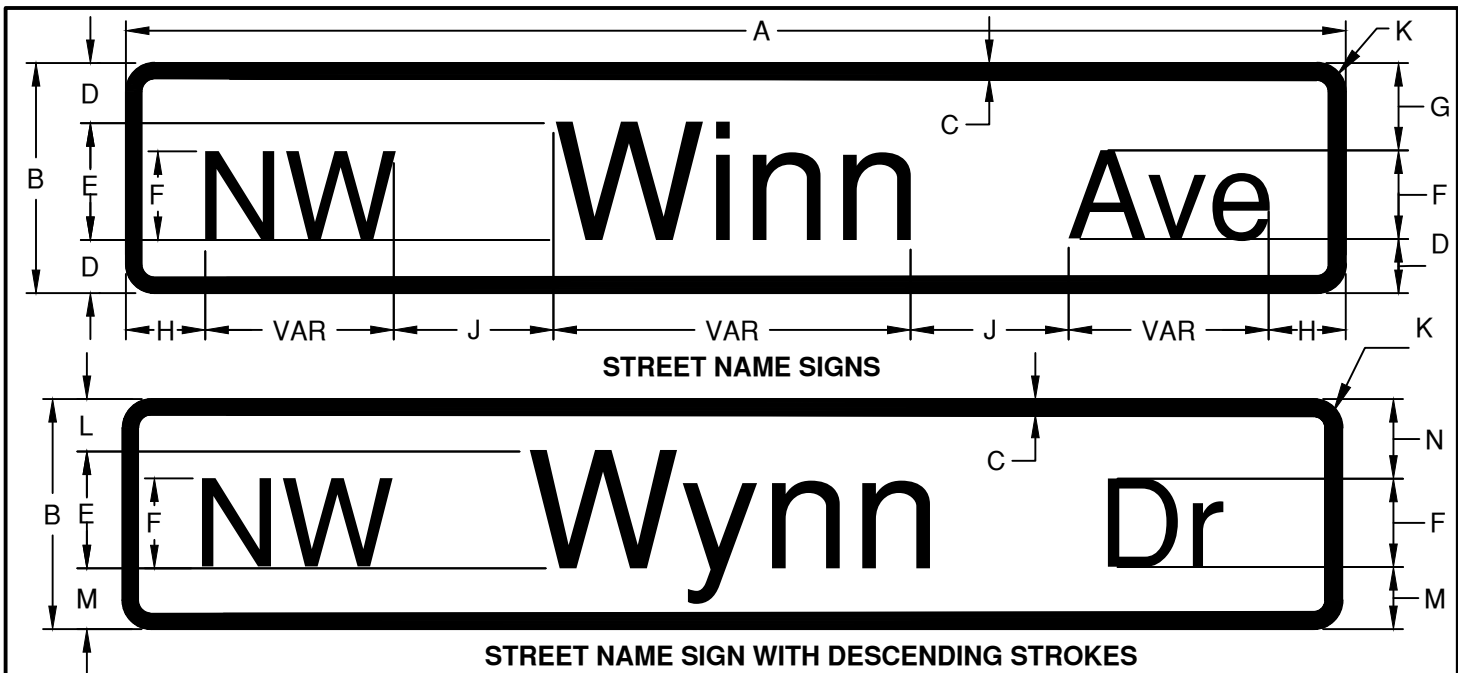

SIGN LOCATION	DIMENSIONS												
	A	B	C	D	E	F	G	H	J	K	L	M	N
LOCAL	VAR	8	0.375	2	4C	3C	3	3 MIN	3	1	1.75	2.25	2.75
COLLECTOR/ ARTERIAL ≤ 40MPH	VAR	12	0.5	3	6C	4.5C	5	4.5 MIN	4.5	1.5	2.75	3.25	4.75
COLLECTOR/ ARTERIAL > 40 MPH	VAR	18	0.75	5	8C	6C	7.67	5.33 MIN	6	1.875	5	5	7.67
OVERHEAD	VAR	24	1	6	12C	9C	10	9 MIN	9	2.25	5	6	9.50

- NOTES:
- SIGNS INSTALLED ALONG PUBLIC STREETS SHALL BE FABRICATED AND INSTALLED TO CONFORM TO THE MUTCD AND CITY OF BEND SPECIFICATIONS.
 - UNLESS OTHERWISE SPECIFIED, STREET NAME SIGNS SHALL BE FABRICATED AS FOLLOWS:
 - SIGN SUBSTRATE: SHEET ALUMINUM (GAUGE 0.80 FOR GROUND-MOUNT) WITH ROUNDED CORNERS
 - RETRO-REFLECTIVE SHEETING: GREEN BACKGROUND WITH WHITE LEGEND, USING HIP/TYPAGE G FOR GROUND-MOUNTED SIGNS, AND DIAMOND GRADE/TYPAGE G2 FOR SIGNS MOUNTED OVERHEAD;
 - LETTERING SHALL BE LOWER-CASE WITH INITIAL UPPER-CASE LETTERS;
 - SERIES C2000 FONT, WITH LETTERING AND LETTER SPACING PER THE FEDERAL HIGHWAY ADMINISTRATION'S STANDARD ALPHABETS AS SHOWN IN THE CURRENT EDITION OF THE STANDARD HIGHWAY SIGNS AND PAVEMENT MARKINGS MANUAL. (* EXCEPT FOR OVERHEAD SIGNS, WHERE SIGNS EXCEED 36" LONG, SERIES B2000 FONT SHALL BE USED);
 - BOTTOM STREET SIGNS (CLOSEST TO THE REGULATORY/STOP SIGN) SHALL BE TWO SINGLE-SIDED WITH PREDRILLED HOLES. SIGNS SHALL BE RIVETED BACK TO BACK ON THE SQUARE TUBE POST, CENTERED ON THE POST.
 - BOTTOM STREET SIGNS SHALL BE USED FOR SIDE STREET (STOP CONTROLLED STREET).
 - TOP STREET SIGN SHALL BE DOUBLE SIDED, TOP SIGN USED FOR MAINLINE STREET (NON-STOP CONTROLLED STREET).
 - ALL SIGNS SHALL BE REVIEWED AND APPROVED BY THE CITY OF BEND ENGINEERING DEPARTMENT PRIOR TO FABRICATIONS AND INSTALLATION.
 - TYPICAL INSTALLATION INCLUDES 2-INCH SQUARE TUBE CAPS WITH 90-DEGREE ANGLE BRACKETS ON 2-INCH PERFORATED SQUARE TUBE STEEL POSTS. USE 5- OR 6-INCH BLADE MOUNTS FOR SIGNS LESS THAN 36" WIDE; 12-INCH MOUNTS FOR SIGNS 36-INCHES OR WIDER OR OVER 6-INCHES HIGH. SEE STANDARD DRAWINGS R-7 AND R-9.
 - SIGN WIDTHS VARY WITH LEGEND. WHERE SITE CONSTRAINTS LIMIT AVAILABLE SPACE, REDUCED LETTER HEIGHT, FONT STYLE, LINE SPACING, OR EDGE SPACING WILL BE CONSIDERED. REDUCTIONS IN SPACING BETWEEN LETTERS OR WORDS IS NOT PERMITTED.
 - WHERE PRIVATE STREETS INTERSECT WITH PUBLIC STREETS, INSTALL A BLACK ON YELLOW PRIVATE DR SIGN WITH 4-INCH CAPITAL LETTERS (ODOT SIGN POLICY SIGN #OW14-3) DIRECTLY BELOW THE PRIVATE STREET NAME SIGN (OR ON A SEPARATE POST, IF NOT AT AN INTERSECTION).
 - FOR ADDITIONAL INFORMATION, REFER TO MUTCD SECTION 2A AND 2D, AND CITY OF BEND TECHNICAL SPECIFICATION SECTION 00940.
 - CONFIRM SIGN SIZE WITH CITY ENGINEER FOR SIGNS ON EXISTING TRAFFIC SIGNAL POLES OR MAST ARMS.
 - LARGER SIGNS ARE PLACE PLACED FACING THE FASTER STREET (COLLECTORS AND ARTERIALS).

DRAWN AJD			 CITY OF BEND	CITY OF BEND STANDARD DRAWING 710 NW WALL ST., BEND, OREGON 97701						SCALE NTS	
DIV ROADWAY										DATE 11/01/2024	
REV	DATE	APPR		STANDARD STREET NAME SIGNS						APPR	
			STD DWG R-8								

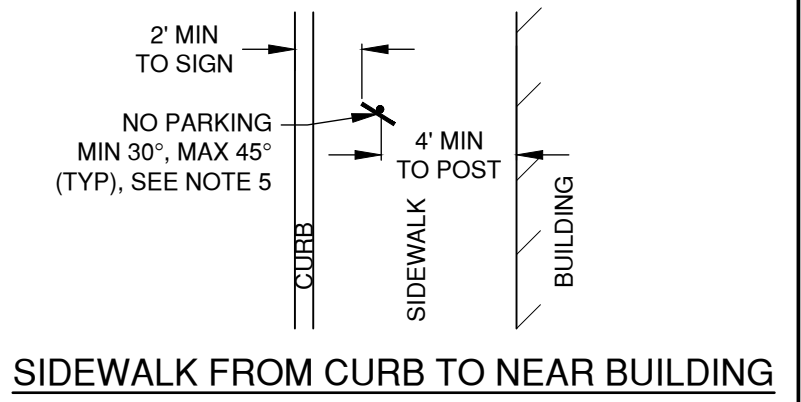
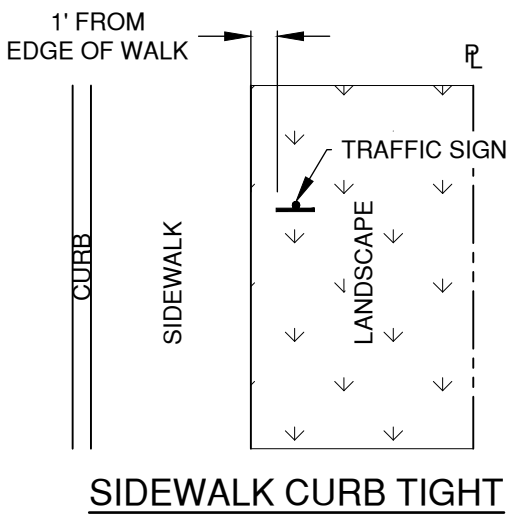
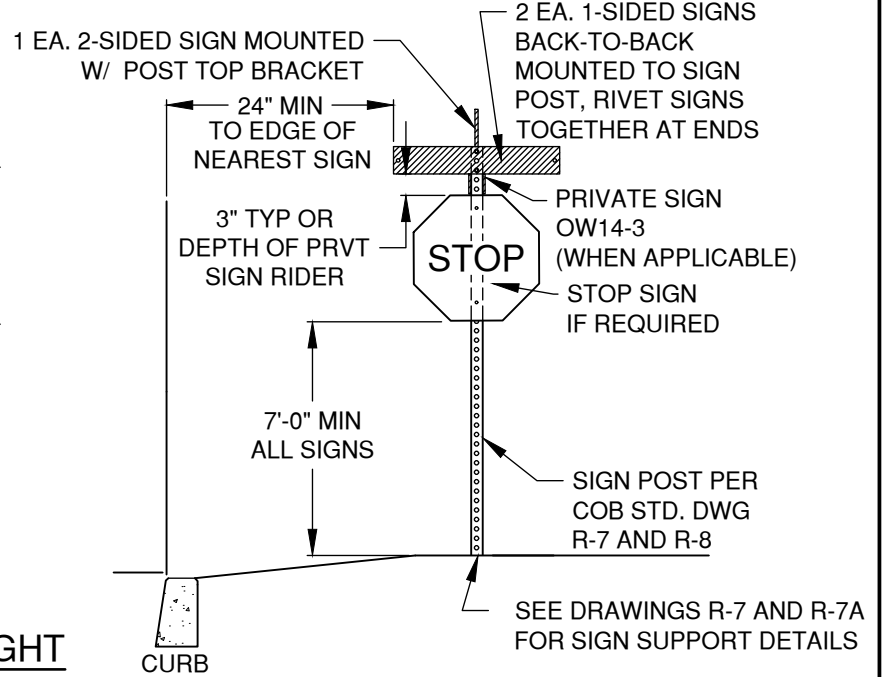
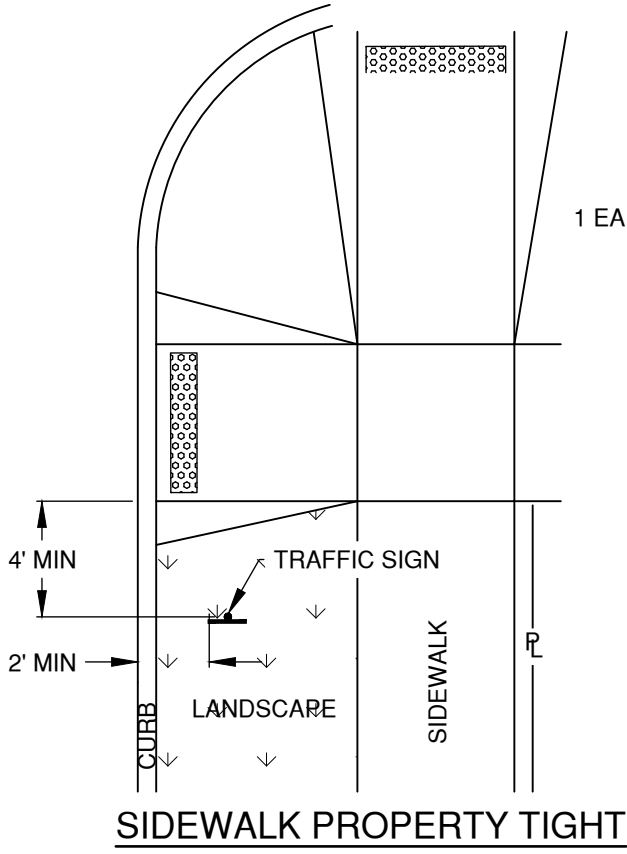

NOTES:

1. SET TO MUTCD SPECS
2. SEE R-8 FOR COB STREET NAME SIGN REQUIREMENTS.
3. CHECK THAT SIGN IS NOT OBSCURED BY VEGETATION, TRIM IF NEEDED.
4. INSTALL ALL SIGNS WITH 5/16"X3/8" DRIVE RIVETS.
5. WHERE NO PARKING SIGN IS USED, IT MUST BE ANGLED.

DRAWN AJD	
DIV ROADWAY	
REV	DATE



CITY OF BEND
STANDARD DRAWING
710 NW WALL ST., BEND, OREGON 97701

STANDARD STREET SIGN PLACEMENT

SCALE NTS
DATE 04/16/2026
APPR
STD DWG R-9

TABLE A	
PIPE DIA (IN)	"A" (IN)
4	10
6	10
8	10
10	10
12	12
15	12
18	16
21	16
24	18
30	18
36	24
42	24
48	24
54	24
60	24
66	24
72	24

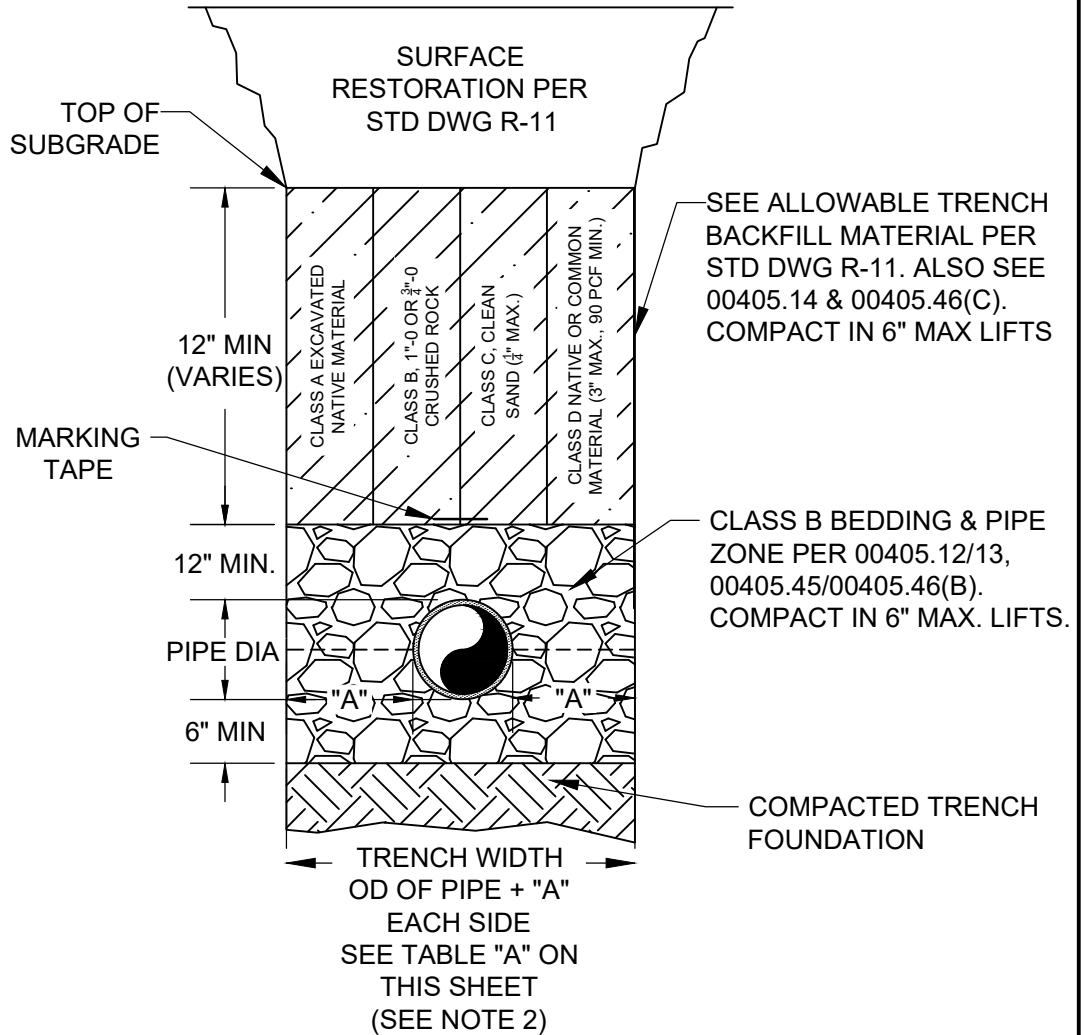

NOTES:

- ALL COMPACTION TO COMPLY WITH SPECIFICATION SECTION 00330.43 AND 00405.46(c).
- A FRANCHISE UTILITY THAT IS A SINGLE CONDUIT AND IS 4 INCHES IN DIAMETER OR LESS MAY BE CENTERED IN A 12-INCH WIDE TRENCH PROVIDED THAT THE TRENCH CAN ACCOMMODATE THE COMPACTION EQUIPMENT. TRENCH PATCH SHALL BE IN ACCORDANCE WITH STD DWG R-11 WHERE THE TEE PATCH SHALL NOT BE LESS THAN 12 INCHES ON BOTH SIDES OF THE TRENCH. OVERALL WIDTH MAY BE REDUCED FROM 4 FEET, BUT IN NO CIRCUMSTANCES RESULT IN TEE PATCHES LESS THAN 12 INCHES AND AN OVERALL MINIMUM WIDTH OF 3 FEET.
- CLASS E - CLSM, MAY BE ALLOWED FOR TRENCH BACKFILL WHERE COMPACTION CANNOT BE MET DUE TO THE PRESENCE OF EXISTING UTILITIES

DRAWN	AJD
DIV	ROADWAY
REV	DATE



CITY OF BEND

CITY OF BEND

STANDARD DRAWING

710 NW WALL ST., BEND, OREGON 97701

TYPICAL TRENCH SECTION

SCALE NTS

DATE 01/31/2022

APPR

STD DWG R-10

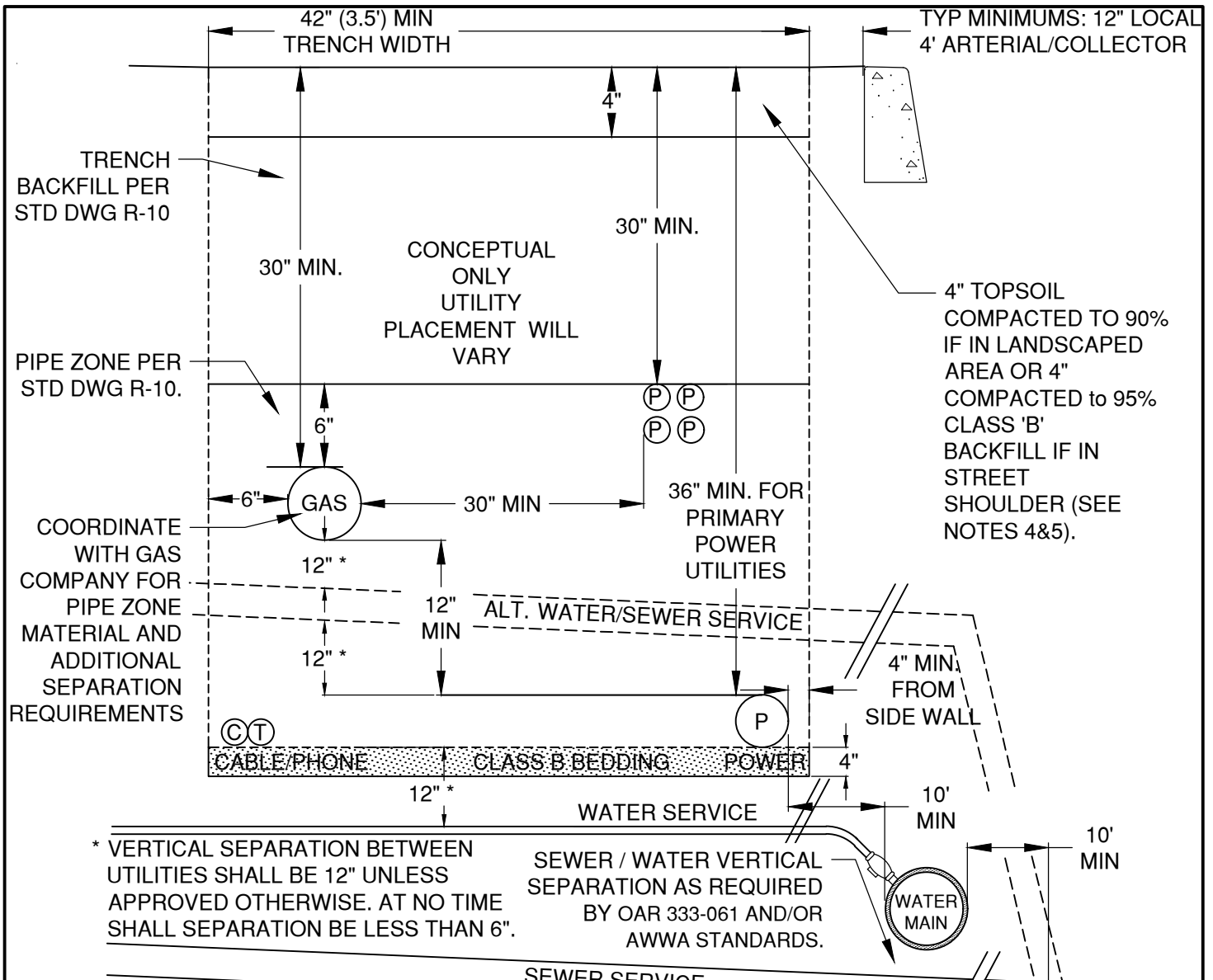

* VERTICAL SEPARATION BETWEEN UTILITIES SHALL BE 12" UNLESS APPROVED OTHERWISE. AT NO TIME SHALL SEPARATION BE LESS THAN 6".

SEWER / WATER VERTICAL SEPARATION AS REQUIRED BY OAR 333-061 AND/OR AWWA STANDARDS.

NOTES:

1. ALL COMPACTION TO COMPLY WITH CITY OF BEND STANDARDS.
2. ALL FRANCHISE UTILITIES SHALL BE INSTALLED IN CONDUIT AS APPROVED BY THE FRANCHISE UTILITY HAVING OWNERSHIP.
3. UTILITY SIZES AND LOCATION SHALL BE DETERMINED BY THE UTILITY COMPANY. LOCATION TO BE SHOWN AND APPROVED BY CITY WITH A RIGHT OF WAY (ROW) PERMIT.
4. WHERE STORM SWALES ARE PROPOSED WITHIN THE LANDSCAPE STRIP, FRANCHISE UTILITIES SHALL BE INSTALLED OUTSIDE OF THE SWALE AREA.
5. TOP SOIL LAYER TO BE COMPACTIONED TO 90% MAX DENSITY. WHERE SIDEWALK IS PLACED OVER FRANCHISE UTILITY TRENCH, NO TOP SOIL SHALL BE PLACED AND SIDEWALK TO BE CONSTRUCTED TO COMPLY WITH CITY STANDARDS R-4A AND R-4B
6. STANDARD SHOWN FOR NEW CONSTRUCTION. MODIFICATIONS SHALL BE MADE WHEN WITHIN EXISTING DEVELOPMENTS WHERE APPROVED BY THE CITY ENGINEER.
7. UTILITIES OUTSIDE THE RIGHT OF WAY SHALL BE WITHIN A PUBLIC UTILITIES EASEMENT (PUE). BACKFILL AND INSTALLATION REQUIREMENTS STILL COMPLY WITH THE PUE.
8. NO SWALES OR SURFACE STORMWATER DRAINAGE FACILITIES ARE PERMITTED OVER FRANCHISE UTILITIES.

DRAWN CJH DIV ROADWAY REV DATE		CITY OF BEND STANDARD DRAWING 710 NW WALL ST., BEND, OREGON 97701	SCALE NTS DATE 11/01/2024
		FRANCHISE UTILITY JOINT TRENCH	APPR STD DWG R-10A

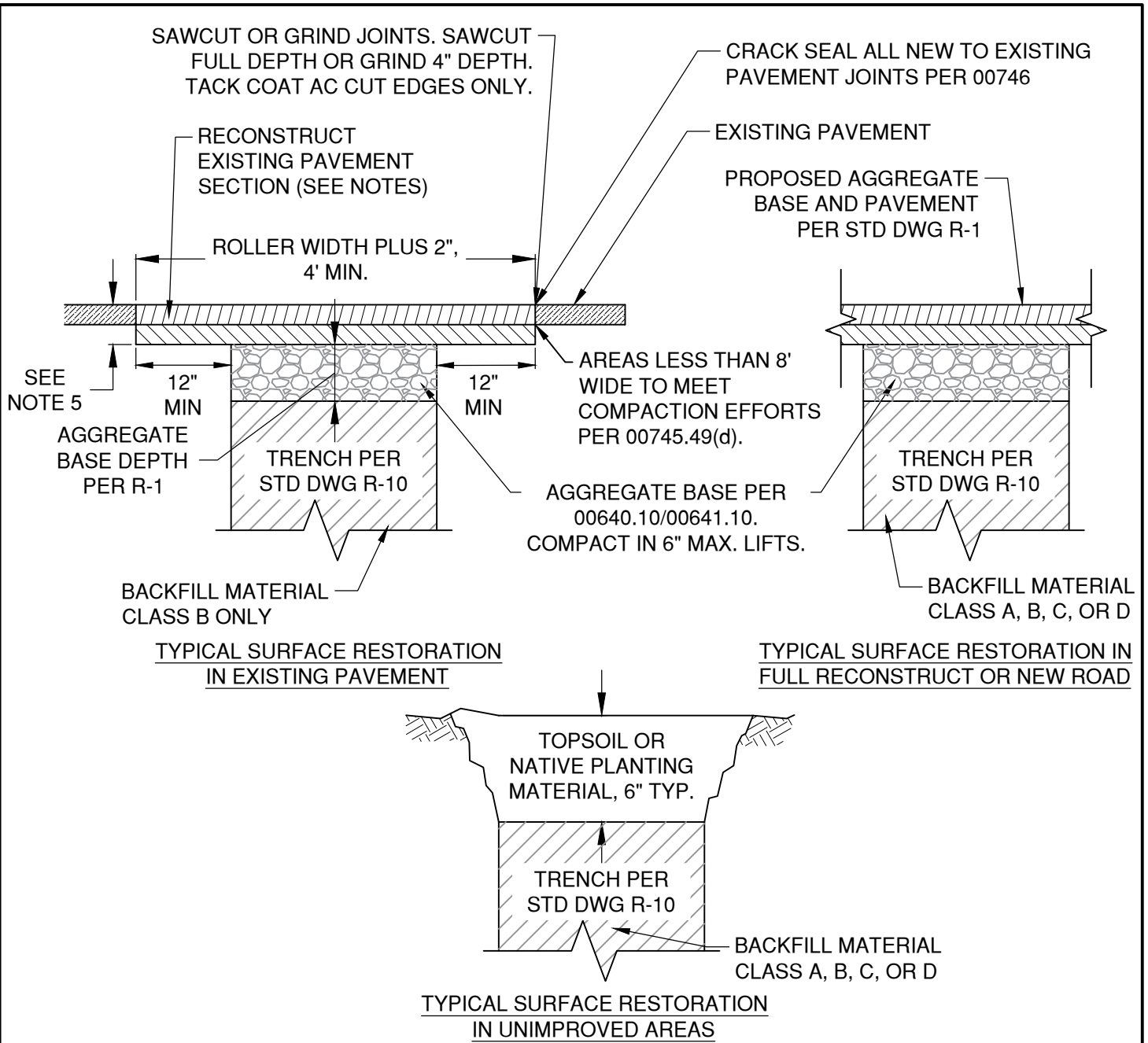

NOTES:

1. SURFACE RESTORATION IN EXISTING PAVEMENT TO COMPLY WITH SPECIFICATION 00495.
2. UNIMPROVED AREA CONSISTS OF ANY PORTION OF THE ROW THAT HAS NOT BEEN IMPROVED TO A CITY STANDARD AND CONSISTS MOSTLY OF NATIVE VEGETATED AREAS. UNIMPROVED AREAS ALSO INCLUDE AREAS WITHIN THE LANDSCAPE STRIP AND PUEs.
3. ALL EXISTING AC OR PCC PAVEMENT SHALL BE SAWCUT PRIOR TO REPAVING. CONCRETE SHALL BE CUT AND REPLACED TO THE NEAREST JOINT(S).
4. CONCRETE PAVEMENT SHALL BE REPLACED WITH CONCRETE TO A MINIMUM THICKNESS OF 6" OR TO THE THICKNESS OF REMOVED PAVEMENT, WHICHEVER IS GREATER
5. PLACE ACP A MINIMUM THICKNESS PER R-1 OR TO THE THICKNESS OF REMOVED PAVEMENT, WHICHEVER IS GREATER. PLACE ACP IN 2" MAX LIFTS.

DRAWN AJD	
DIV ROADWAY	
REV	DATE



CITY OF BEND

CITY OF BEND

STANDARD DRAWING

710 NW WALL ST., BEND, OREGON 97701

TRENCH SURFACE RESTORATION

SCALE NTS

DATE 01/31/2022

APPR

STD DWG R-11

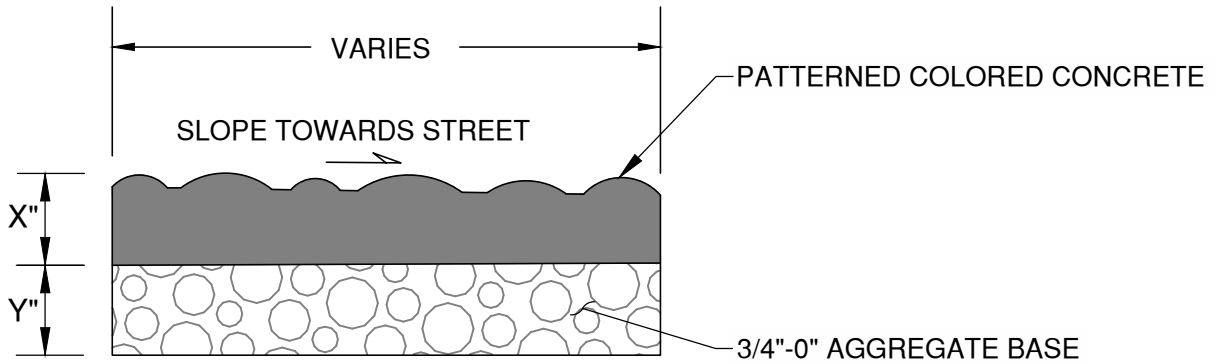

X DIMENSION:

- MEDIAN/ALL ADJACENT TO TRAVEL LANE = 6"
- ONLY BACK SIDE OF SIDEWALK OR SEPARATE FROM TRAVEL LANE = 4"
- TRUCK APRON = 9"

Y DIMENSION:

- MEDIAN/ALL ADJACENT TO TRAVEL LANE = 6"
- ONLY BACK SIDE OF SIDEWALK OR SEPARATE FROM TRAVEL LANE = 4"
- TRUCK APRON = 6"

NOTE:

1. STAMPED CONCRETE SURFACE TEXTURE PATTERN SHALL BE BRICKFORM "FLAGSTONE" TM-700) WITH SAWCUT GROOVE JOINTS 1/3 CONCRETE DEPTH.
2. GLAZE AND SEAL PER MANUFACTURERS SPECS.
3. INTEGRAL COLOR: DAVIS SPANISH GOLD (3 LBS. #5084)
4. RELEASE COLOR: DAVIS DARK GREY (#860)

DRAWN AJD		 CITY OF BEND	CITY OF BEND STANDARD DRAWING 710 NW WALL ST., BEND, OREGON 97701	SCALE NTS
DIV ROADWAY				DATE 01/31/2022
REV	DATE			APPR
PATTERNED COLORED CONCRETE DETAIL			STD DWG R-24	

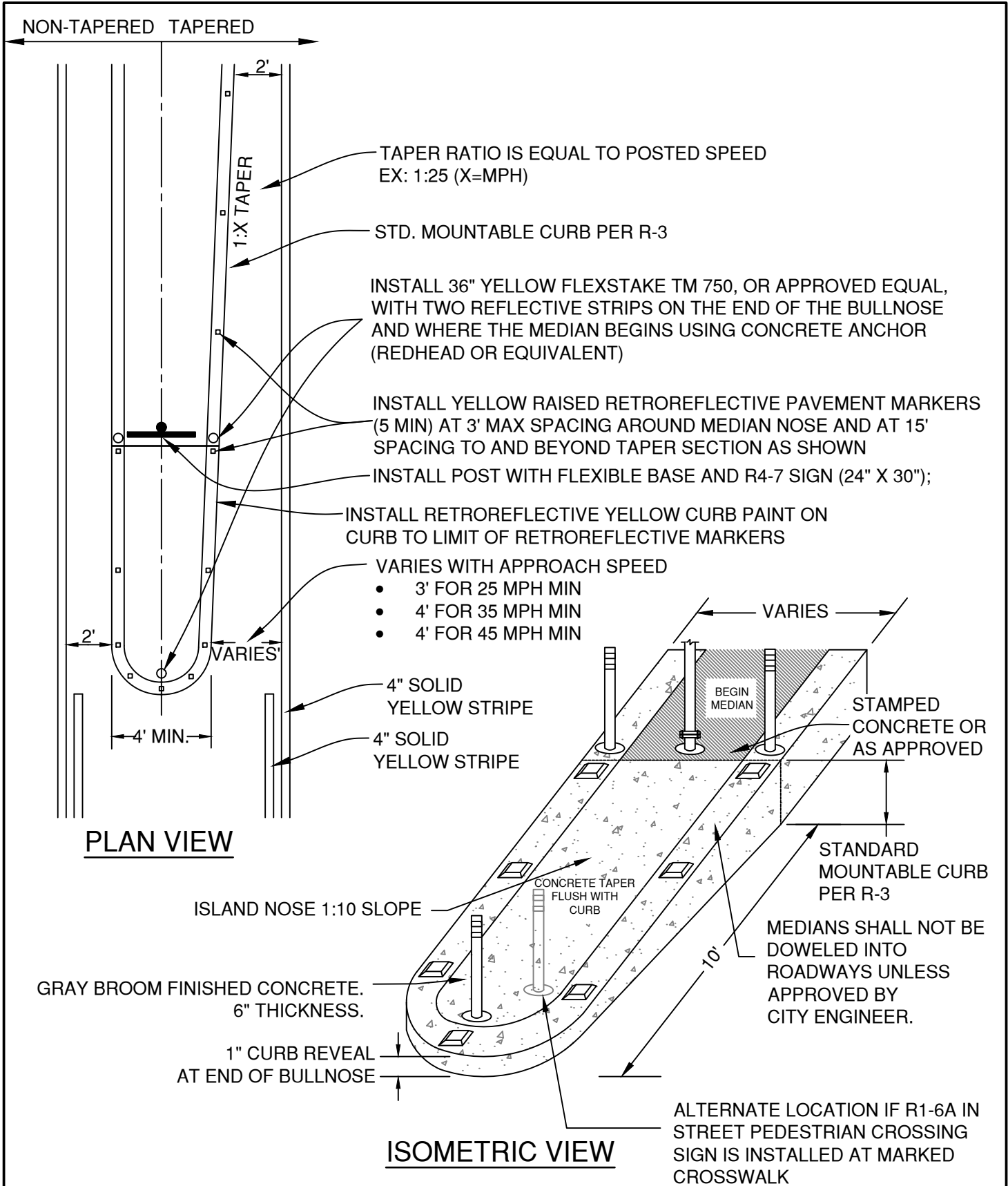

DRAWN ARI	
DIV ROADWAY	
REV	DATE



CITY OF BEND
STANDARD DRAWING
710 NW WALL ST., BEND, OREGON 97701

MEDIAN / ISLAND END DETAIL

SCALE NTS
DATE 04/16/2026
APPR
STD DWG R-25

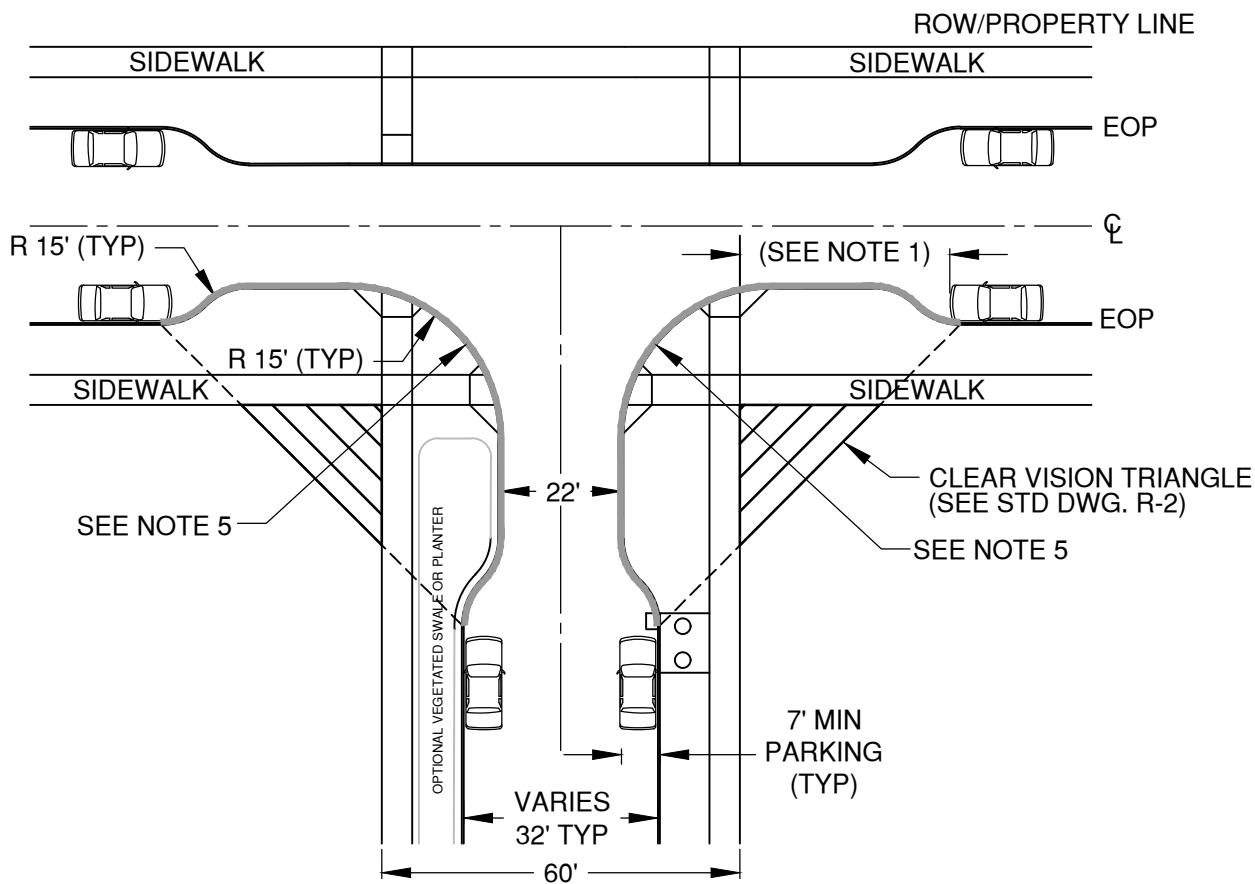

NOTES:

1. NO PARKING WITHIN THE CLEAR VISION OR 20 FEET OF THE INTERSECTION, WHICHEVER IS GREATER.
2. AS REQUIRED BY THE CITY ENGINEER, INSTALL YELLOW 36" TALL YELLOW SURFACE MOUNTED TUBULAR MARKERS, PER SPECIFICATION SECTION 00856 FOR PLOW SIGNAGE AT CURB EXTENSIONS.
3. USE LOW GROWING VEGETATION FOR BIORETENTION SWALES/ PLANTERS LOCATED IN CURB EXTENSIONS.
4. CURB RETURNS TO BE CONSTRUCTED PER DESIGN STANDARD.
5. YELLOW CURB PAINT ON RETURNS IS REQUIRED IN COMMERCIAL AND HIGH DENSITY RESIDENTIAL AREAS

DRAWN AJD	
DIV ROADWAY	
REV	DATE



CITY OF BEND

CITY OF BEND

STANDARD DRAWING

710 NW WALL ST., BEND, OREGON 97701

LOCAL STREET CURB EXTENSIONS

SCALE NTS

DATE 01/31/2022

APPR

STD DWG R-26

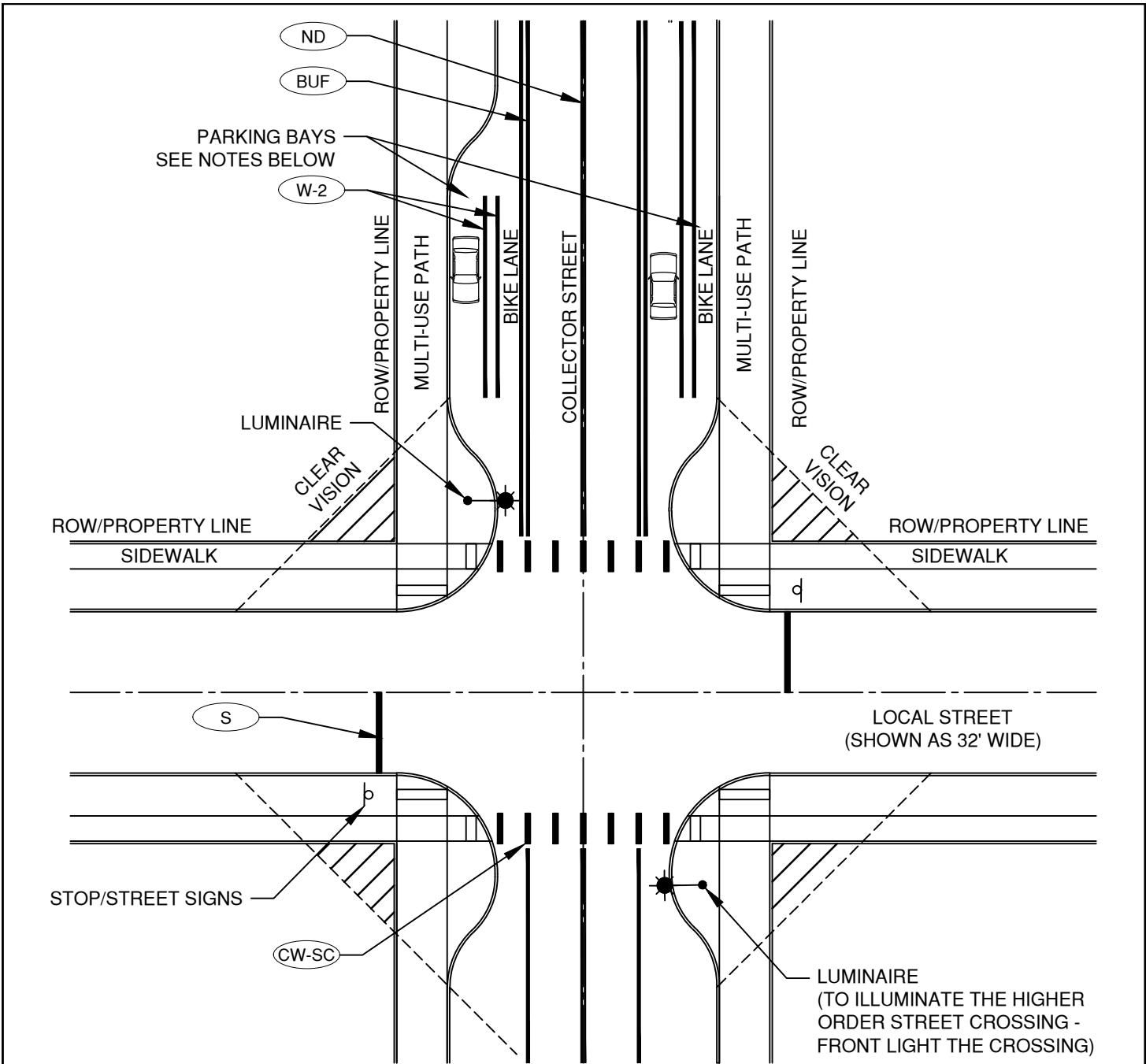

NOTES:

1. PARKING BAYS SHALL BE DESIGNED OUTSIDE THE CLEAR VISION OF THE INTERSECTION. PARKING WILL BE PERMITTED IF CLEAR VISION AND SIGHT DISTANCE AS ANALYZED AS SAFE BY A PROFESSIONAL ENGINEER.
2. PARKING BAYS ON COLLECTORS ARE PERMITTED AS DIRECTED BY THE DEVELOPMENT CODE.
3. NO MORE THAN 10 PARKING BAYS WILL BE PERMITTED TOGETHER. TERMINATION OF BAYS WILL BE FOR VEGETATION PLANTING, UTILITY INSTALLATION (FRANCHISE UTILITY VAULTS, STORM FACILITIES, ETC).
4. PARKING IS NOT PERMITTED WITHIN THE INTERSECTION'S CLEAR VISION AND SIGHT DISTANCE AS DETERMINED BY AASHTO REQUIREMENTS AND ENGINEER REVIEW.
5. USE PARKING SEPARATED BIKE LANE WHERE PARKING BAYS ARE LONG/BLOCK LENGTH AND ADEQUATE EXIT/ENTER SIGHT DISTANCE CAN BE PROVIDED.

DRAWN AJD	
DIV ROADWAY	
REV	DATE



CITY OF BEND
 STANDARD DRAWING
 710 NW WALL ST., BEND, OREGON 97701
COLLECTOR / LOCAL INTERSECTION

SCALE NTS
DATE 11/01/2024
APPR
STD DWG R-27

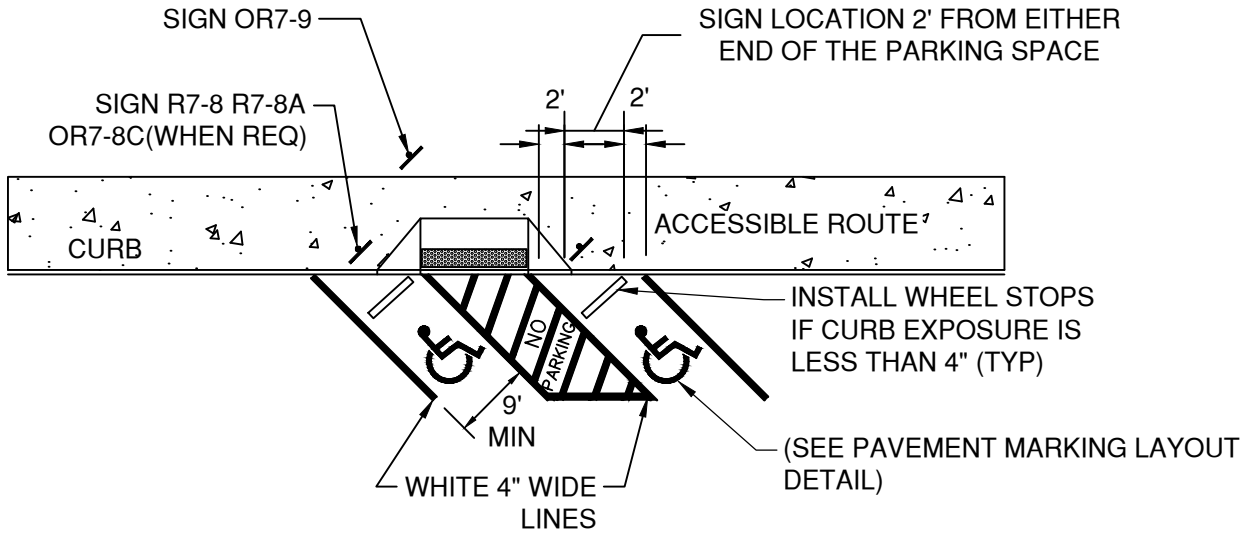

ANGLED PARKING PLAN

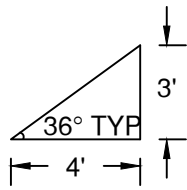

ACCESS AISLE ANGLE LAYOUT

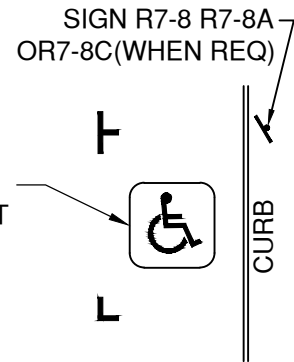

PARALLEL PARKING PLAN

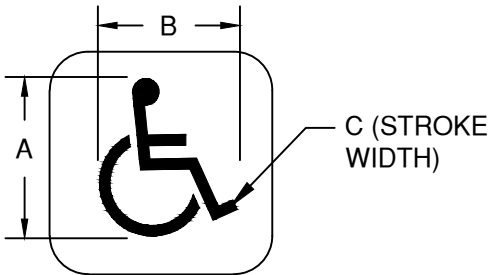

LEGEND	DIMENSIONS (INCHES)		
	A	B	C
MINIMUM	28	24	3
STANDARD	41	36	4

PAVEMENT MARKING LAYOUT

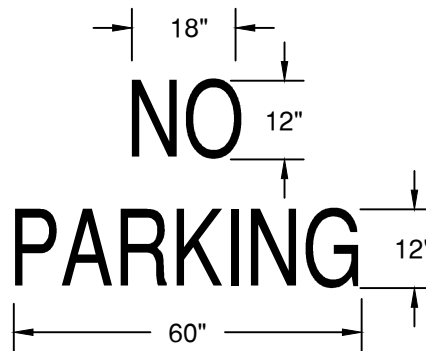

NOTE:

1. THIS IS ONE EXAMPLE OF AN ACCESSIBLE PARKING CONFIGURATION. REFER TO ODOT ACCESSIBLE PARKING STANDARDS FOR ADDITIONAL DETAILS AND OTHER CONFIGURATIONS.
2. ALL SIGNS AND PLACEMENT SHALL CONFORM TO ODOT STANDARDS.

DRAWN	AJD
DIV	ROADWAY
REV	DATE



CITY OF BEND

CITY OF BEND

STANDARD DRAWING

710 NW WALL ST., BEND, OREGON 97701

ACCESSIBLE PARKING - ANGLE

SCALE NTS

DATE 01/31/2022

APPR

STD DWG R-29

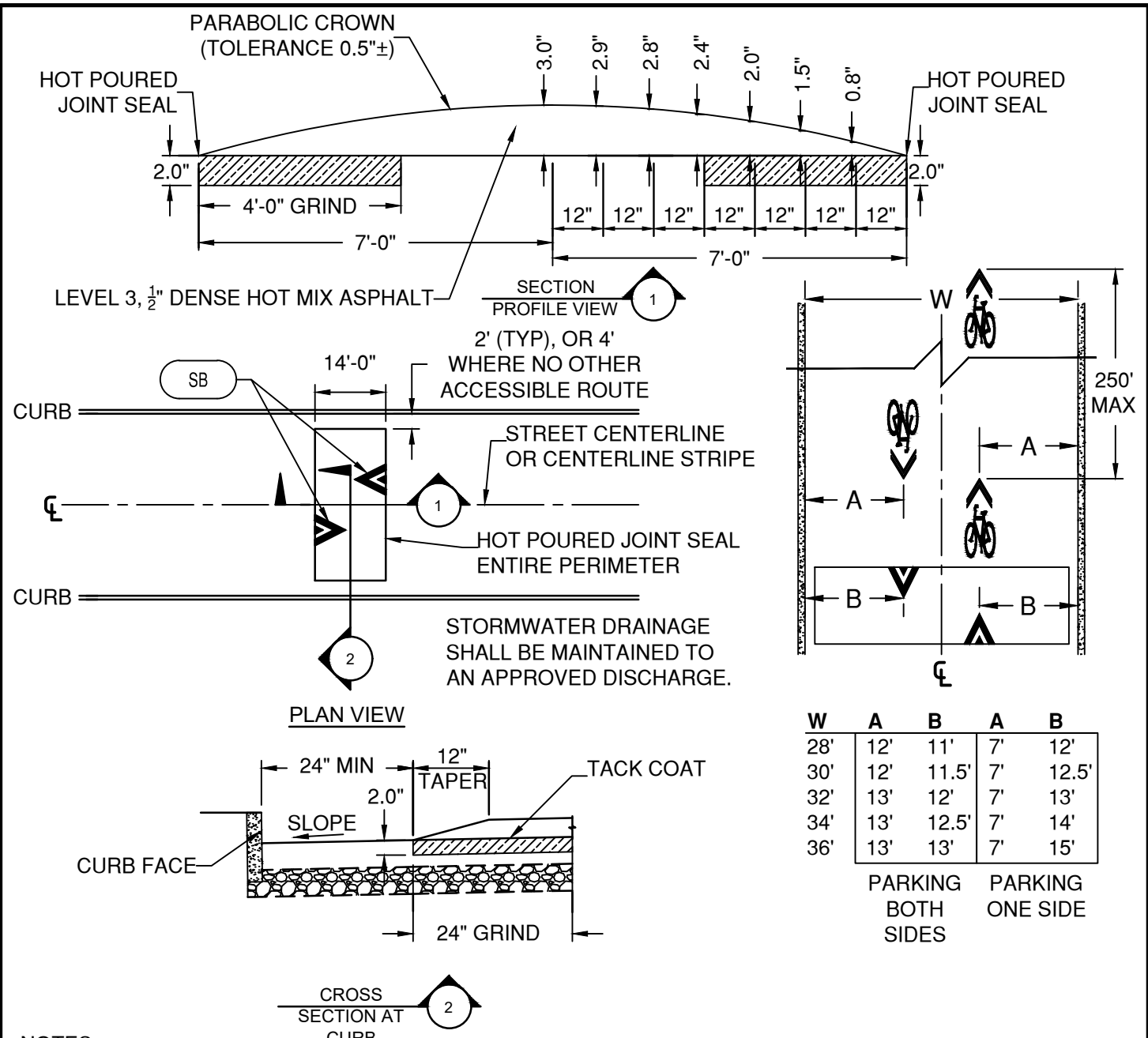

NOTES:

1. SPEED HUMPS ARE ONLY PERMITTED IN SELECT LOCATIONS. REFER TO CITY DESIGN STANDARDS.
2. WHERE SPEED HUMP IS A RETRO-FIT TO AN EXISTING ROAD:
 - 2.1. GRIND / KEY-IN PERIMETER TO THE DIMENSIONS SHOWN OR AS DIRECTED BY THE ENGINEER.
 - 2.2. APPLY TACK COAT TO ALL EXISTING SURFACES WHERE SPEED HUMP WILL BE IN CONTACT.
3. HOT POURED JOINT SEAL THE ENTIRE PERIMETER AFTER INSTALLATION.
4. ALL VERTICAL DIMENSIONS HAVE A REQUIRED MAXIMUM TOLERANCE OF +/- 1/4".
5. THE DISTANCE BETWEEN CURB AND EDGE OF THE SPEED HUMP VARIES. SEE ENGINEERED PLANS.
6. PAVEMENT MARKINGS ON SPEED BUMP SHALL BE INSTALLED CONCURRENTLY WITH THE ASPHALT STRUCTURES. PAVEMENT MARKINGS SHALL BE THERMO-PLASTIC.
7. PAVEMENT MARKINGS SHALL BE INSTALLED BEFORE OPENING ANY LANE TO TRAFFIC THAT IS OCCUPIED BY A NEW SPEED BUMP.
8. SPEED HUMPS ARE NOT PERMITTED IN ACCESSIBLE ROUTES OR WHERE IN CONFLICT WITH DRIVEWAYS.

DRAWN AJD	
DIV ROADWAY	
REV	DATE



CITY OF BEND

STANDARD DRAWING

710 NW WALL ST., BEND, OREGON 97701

SPEED HUMPS AND SHARROW PLACEMENT

SCALE NTS
DATE 01/31/2022
APPR
STD DWG R-32

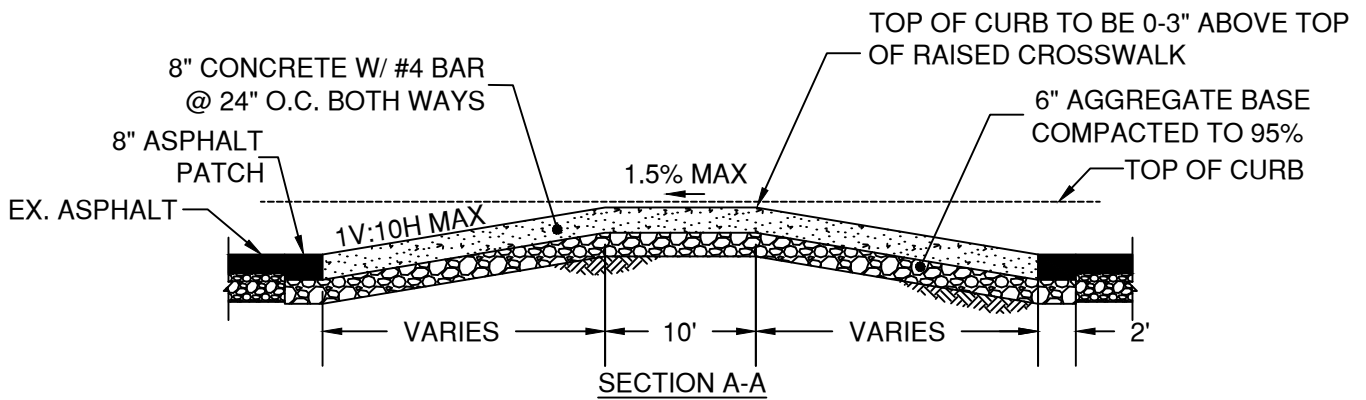
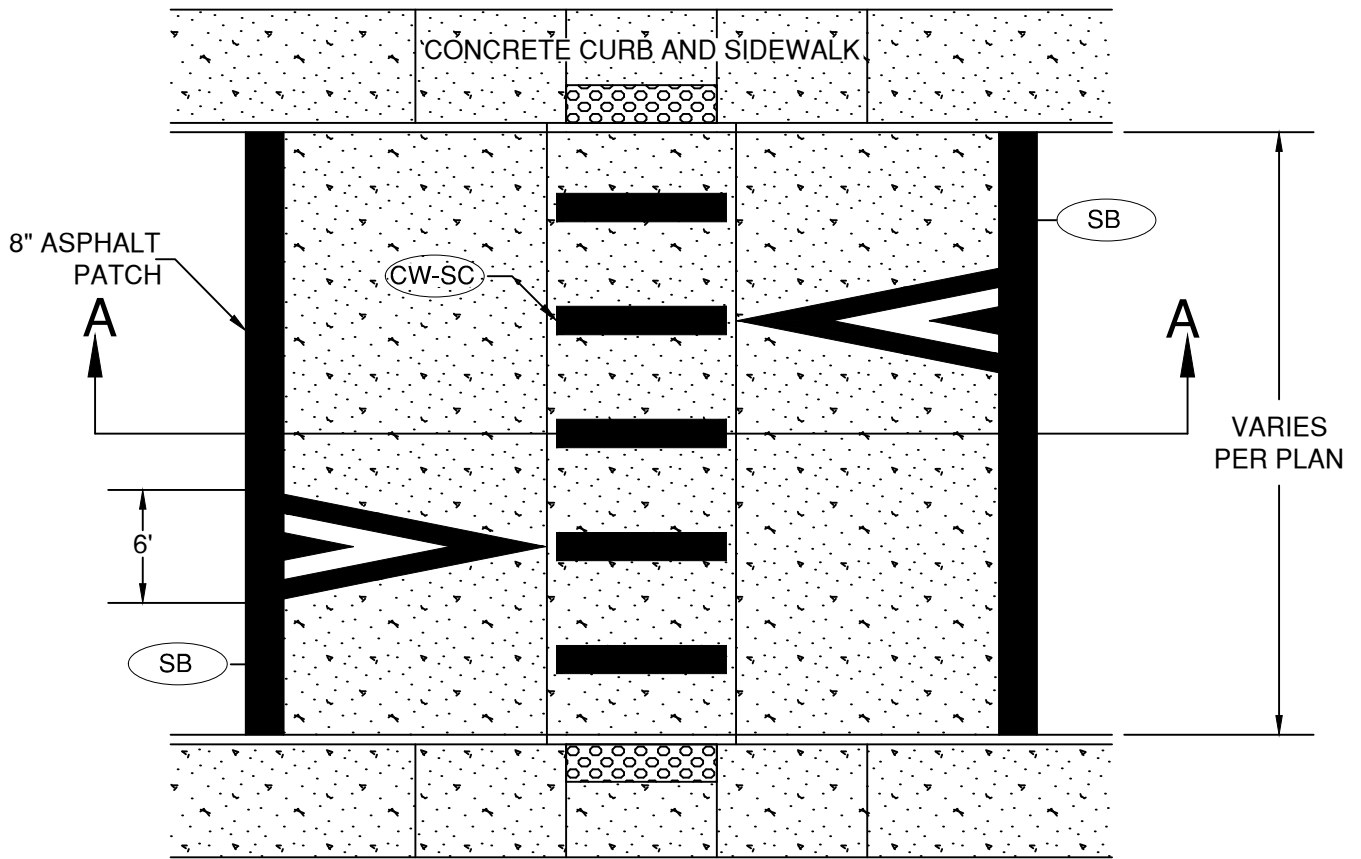

NOTES:

1. RAISED CROSSWALKS ARE ONLY PERMITTED IN SELECT LOCATIONS. REFER TO CITY DESIGN STANDARDS.
2. HOT POURED JOINT SEAL THE ENTIRE PERIMETER AFTER INSTALLATION.
3. PAVEMENT MARKINGS ON RAISED CROSSWALKS SHALL BE THERMO-PLASTIC.
4. PAVEMENT MARKINGS SHALL BE INSTALLED BEFORE OPENING ANY LANE TO TRAFFIC THAT IS OCCUPIED BY A NEW SPEED BUMP.

DRAWN AJD
 DIV ROADWAY
 REV DATE



CITY OF BEND

CITY OF BEND
 STANDARD DRAWING

710 NW WALL ST., BEND, OREGON 97701

RAISED CROSSWALK

SCALE NTS

DATE 01/31/2022

APPR

STD DWG R-33

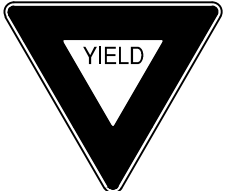
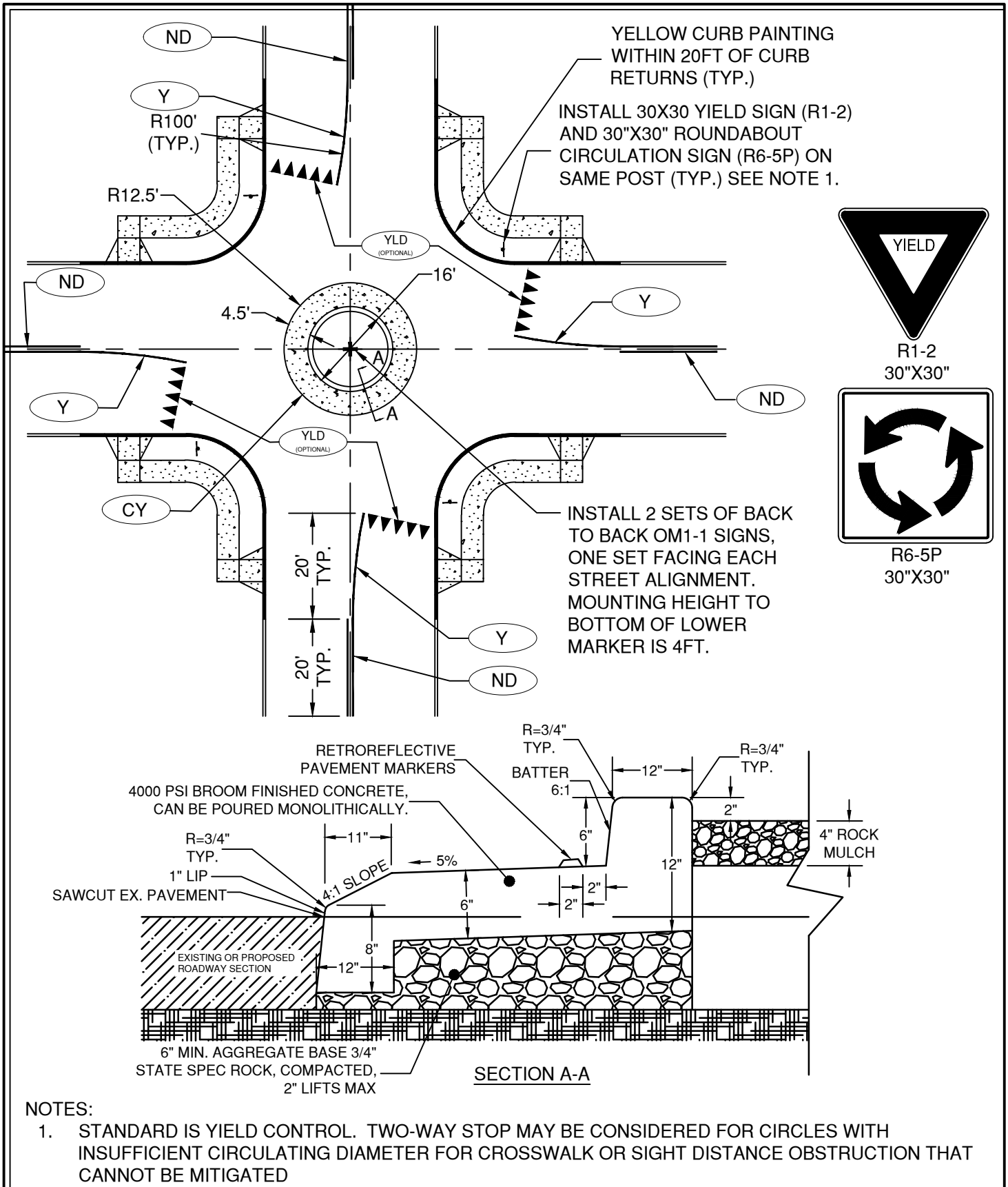

R1-2
30"X30"

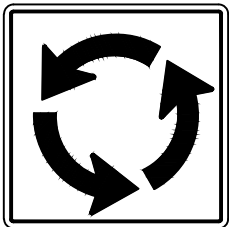

R6-5P
30"X30"

SECTION A-A

- NOTES:
- STANDARD IS YIELD CONTROL. TWO-WAY STOP MAY BE CONSIDERED FOR CIRCLES WITH INSUFFICIENT CIRCULATING DIAMETER FOR CROSSWALK OR SIGHT DISTANCE OBSTRUCTION THAT CANNOT BE MITIGATED

DRAWN AJD	
DIV ROADWAY	
REV	DATE



CITY OF BEND
STANDARD DRAWING
710 NW WALL ST., BEND, OREGON 97701

TRAFFIC CIRCLE

SCALE NTS
DATE 01/31/2022
APPR
STD DWG R-34

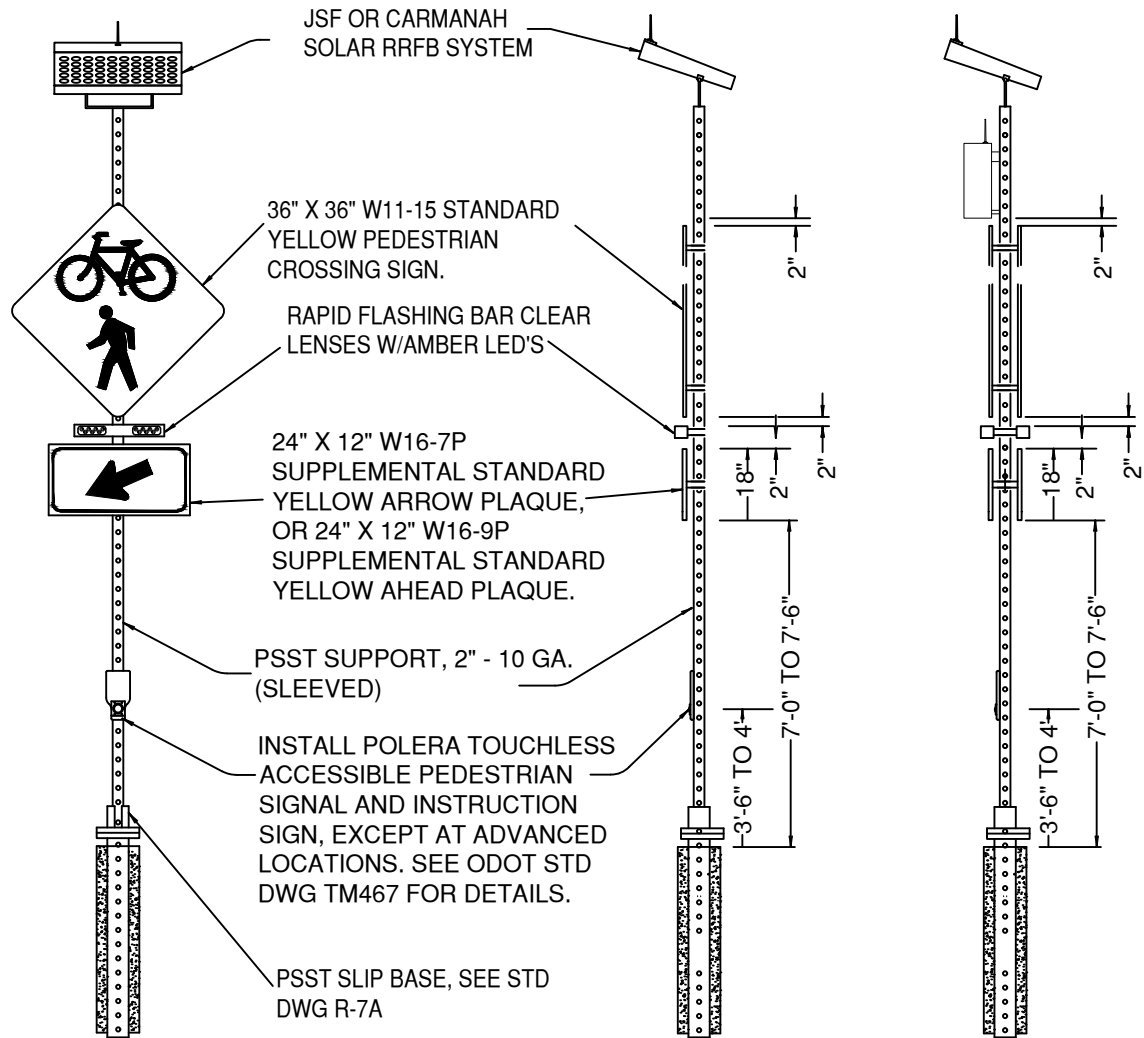

FRONT VIEW

SINGLE SIDED
SIDE VIEW

TWO SIDED
SIDE VIEW

RECTANGULAR RAPID FLASHING BEACON SYSTEM
PSST INSTALLATION

NOTES:

1. REMOVE SOLAR EQUIPMENT IF USING COMMERCIAL POWER
2. USE APPLIED INFORMATION AI-500-030 LOW POWER MONITORING DEVICE
3. USE SCHOOL CROSSING (S1-1) FOR DESIGNATED SCHOOL CROSSING
4. USE DOUBLE SIDED SIGNS IN MEDIANS
5. ADD RADIO NETWORK CONTROLLER (APPLIED INFORMATION CONTROLLER GLANCE LOW POWER MONITORING DEVICE) INCLUDING ANY RETROFIT / MOUNTING KIT.

DRAWN ARI
DIV ROADWAY

REV DATE



CITY OF BEND

CITY OF BEND

STANDARD DRAWING

710 NW WALL ST., BEND, OREGON 97701

RECTANGULAR RAPID FLASHING BEACON

SCALE NTS

DATE 04/16/2026

APPR

STD DWG R-35A

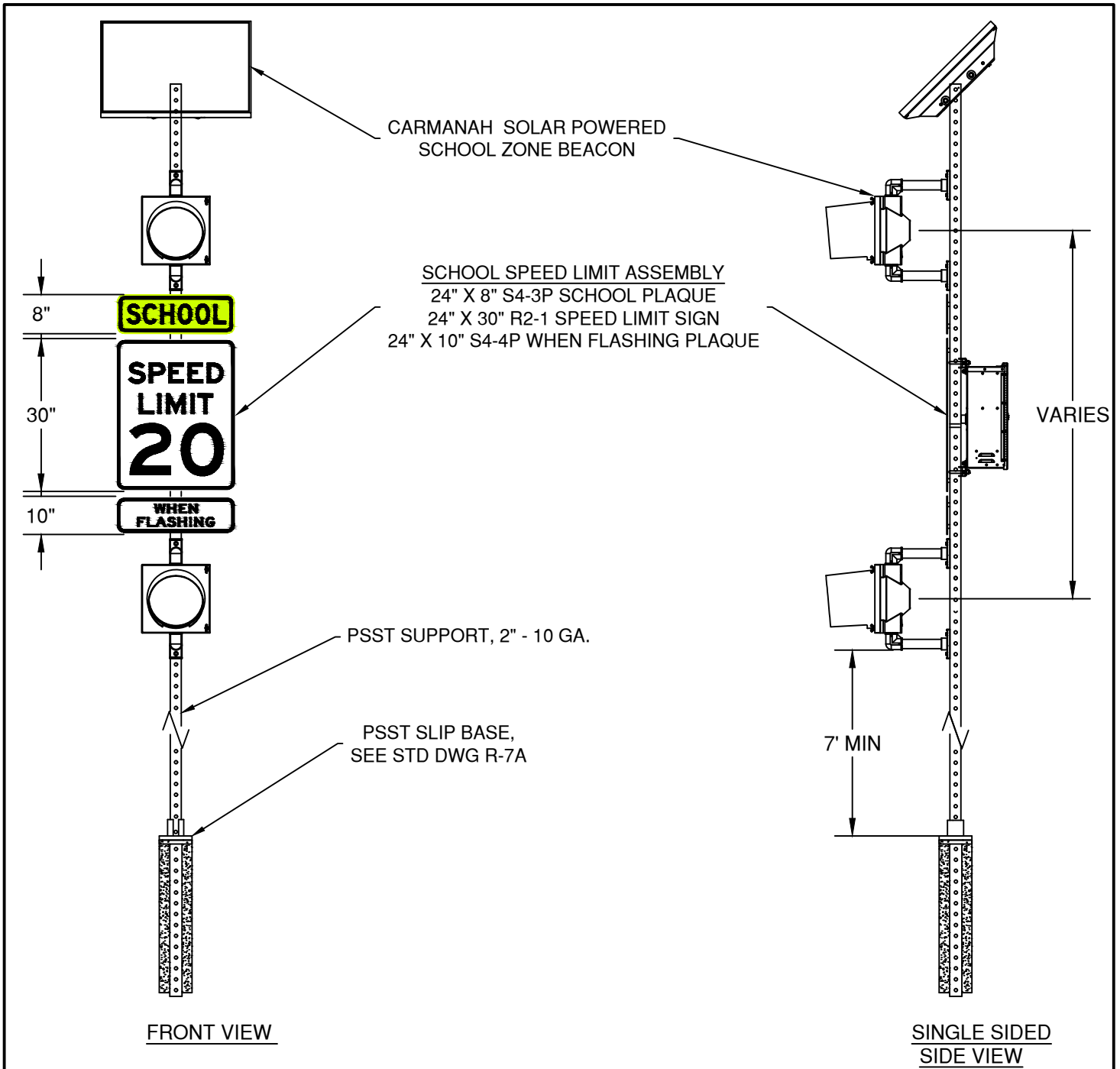

SOLAR POWER SCHOOL ZONE BEACON
PSST INSTALLATION

NOTES:

1. REMOVE SOLAR EQUIPMENT IF USING COMMERCIAL POWER
2. ADD RADIO NETWORK CONTROLLER FOR WIRELESS EQUIPMENT IF NEEDED
3. ADD RADIO NETWORK CONTROLLER (APPLIED INFORMATION CONTROLLER GLANCE LOW POWER MONITORING DEVICE) INCLUDING ANY RETROFIT / MOUNTING KIT.

DRAWN AJD	
DIV ROADWAY	
REV	DATE



CITY OF BEND

CITY OF BEND

STANDARD DRAWING

710 NW WALL ST., BEND, OREGON 97701

FLASHING SCHOOL ZONE BEACON

SCALE NTS

DATE 11/01/2024

APPR

STD DWG R-35B

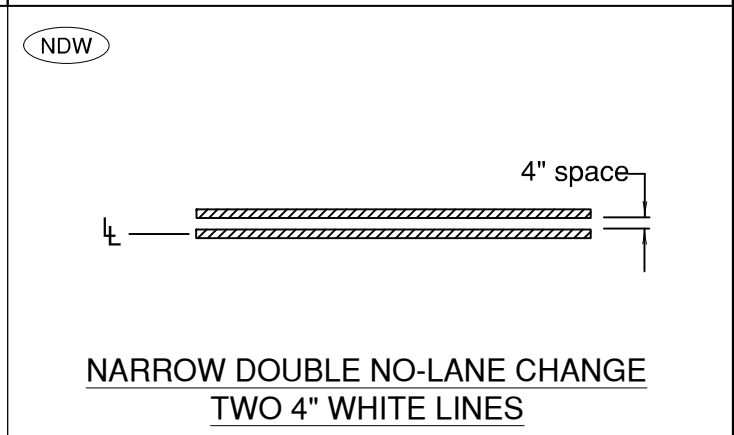
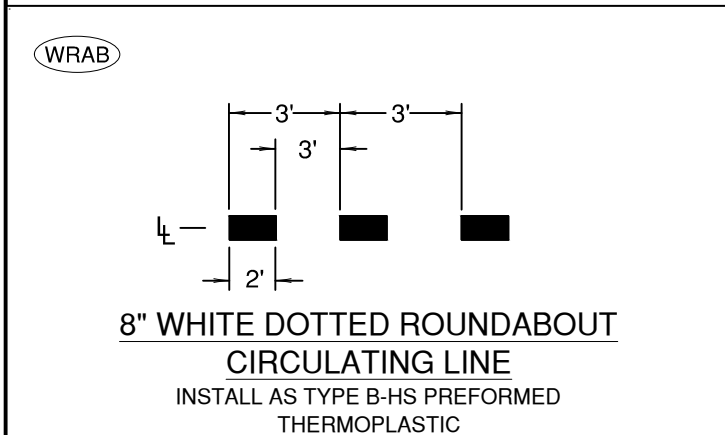
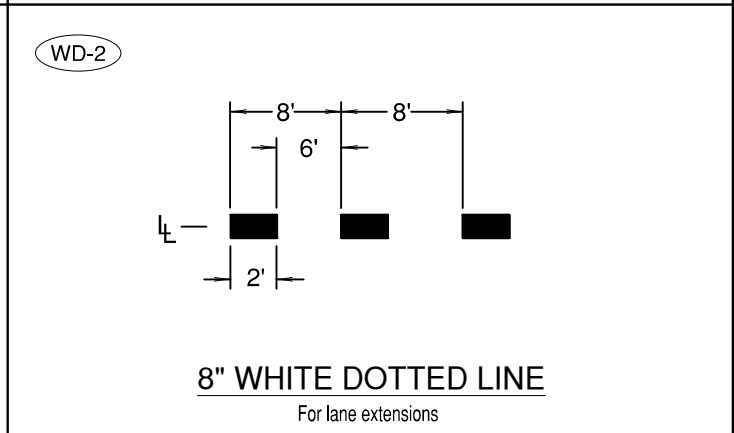
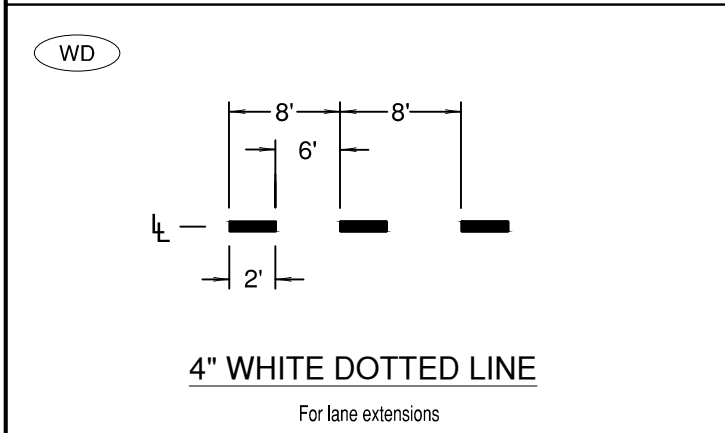
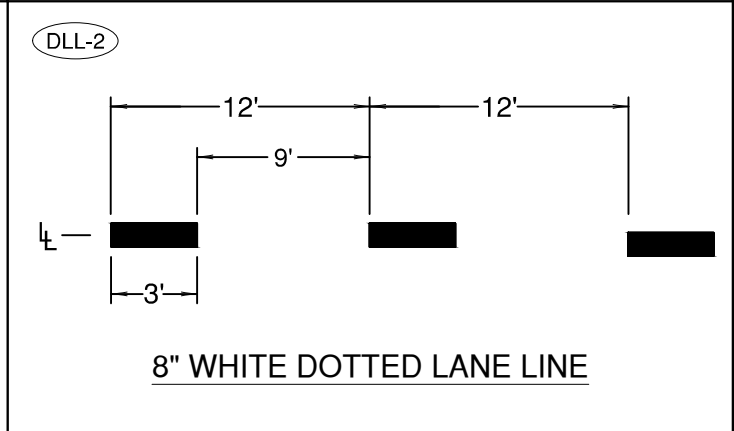
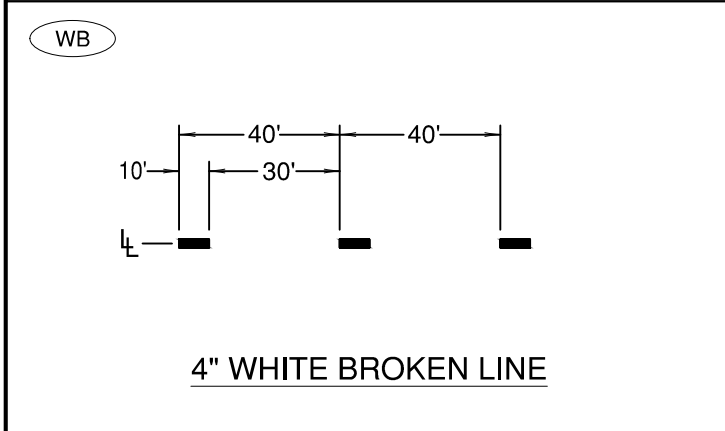
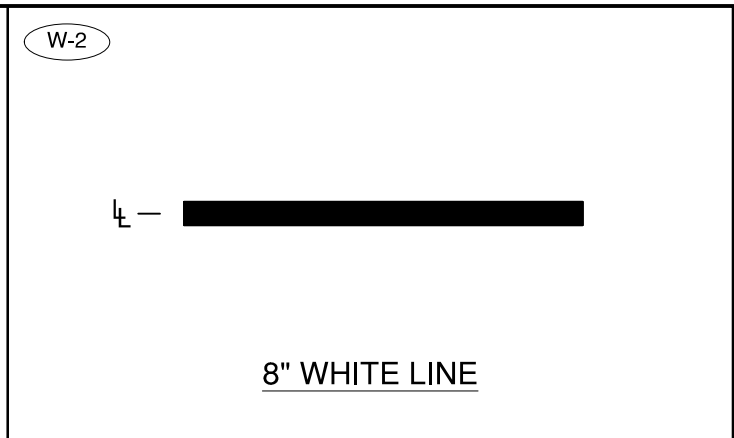
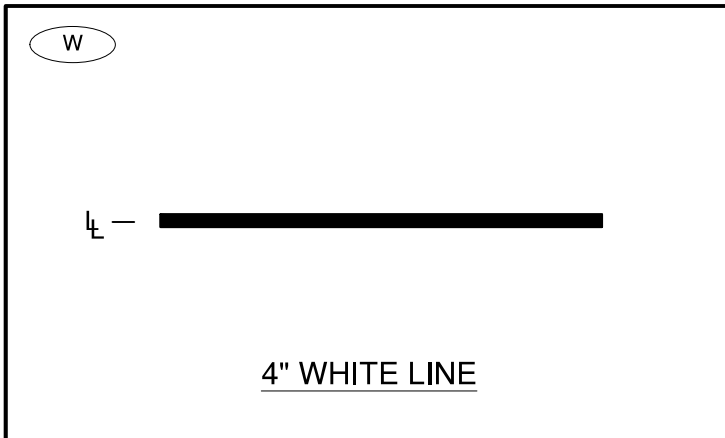

DRAWN AJD	
DIV ROADWAY	
REV	DATE



CITY OF BEND
STANDARD DRAWING
710 NW WALL ST., BEND, OREGON 97701

PAVEMENT MARKINGS - WHITE

SCALE NTS
DATE 01/31/2022
APPR
STD DWG R-40

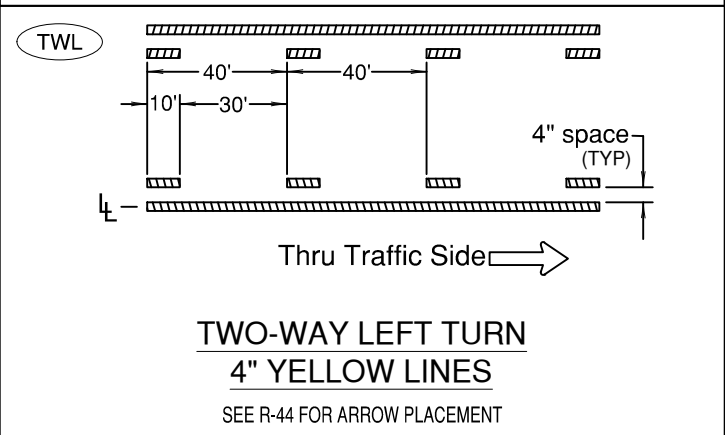
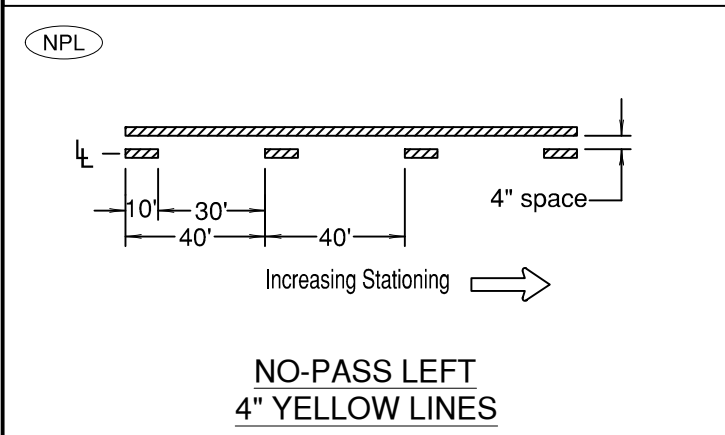
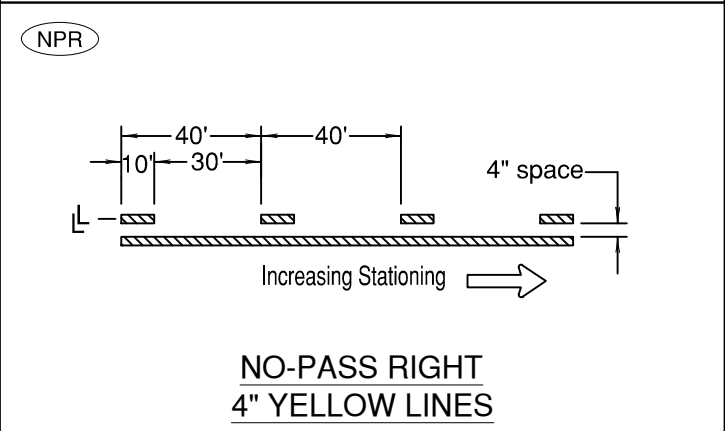
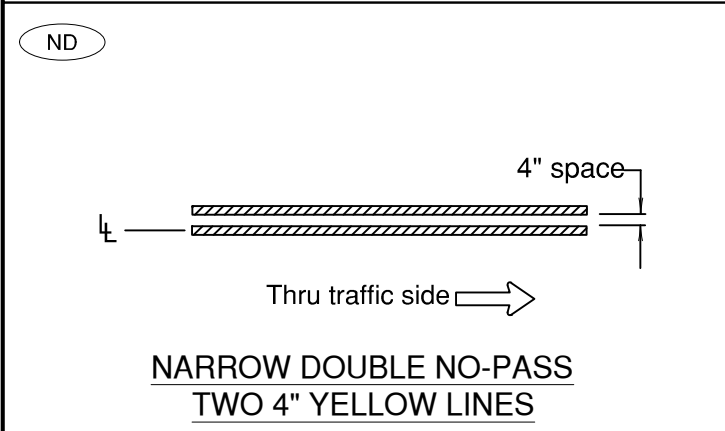
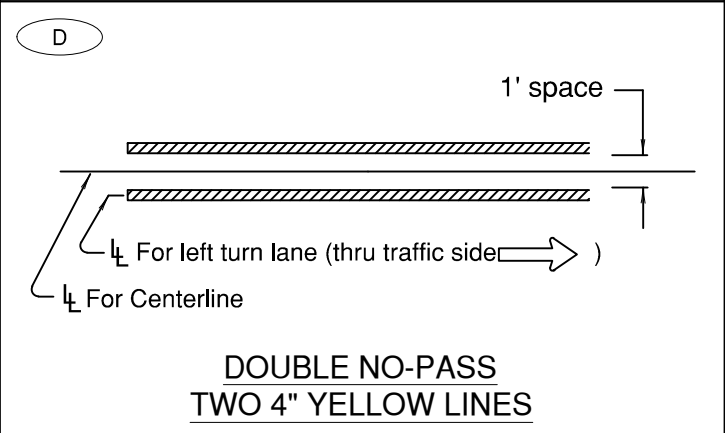
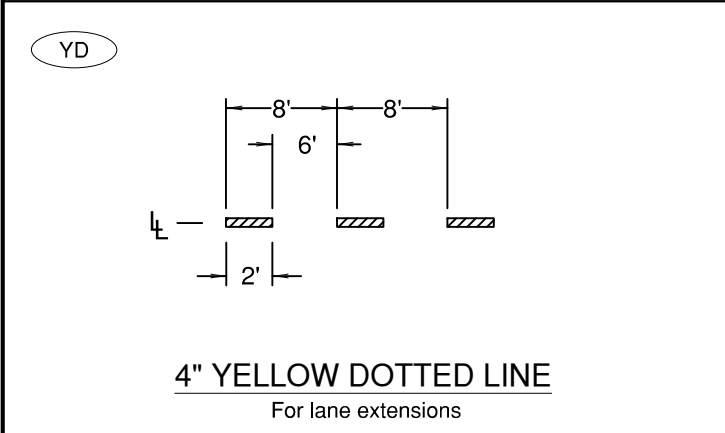
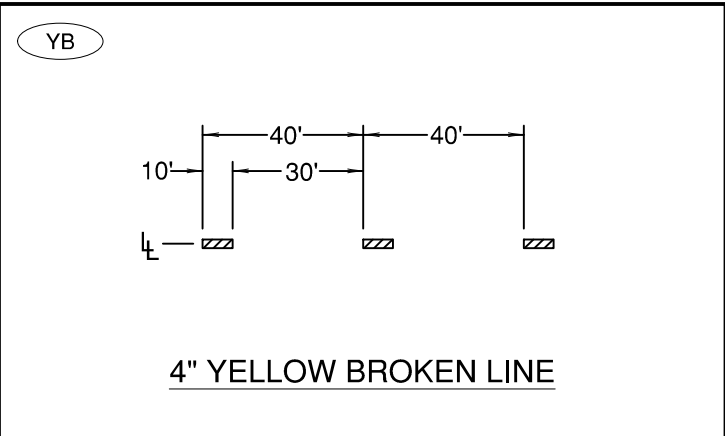
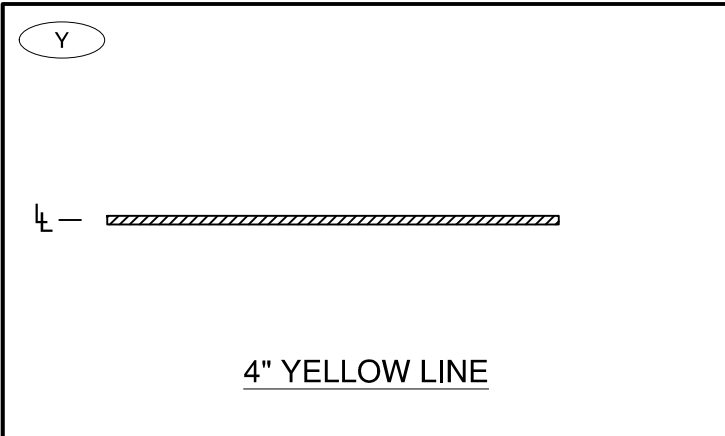

DRAWN AJD	
DIV ROADWAY	
REV	DATE



CITY OF BEND
 STANDARD DRAWING
 710 NW WALL ST., BEND, OREGON 97701
PAVEMENT MARKINGS - YELLOW

SCALE NTS
DATE 01/31/2022
APPR
STD DWG R-41

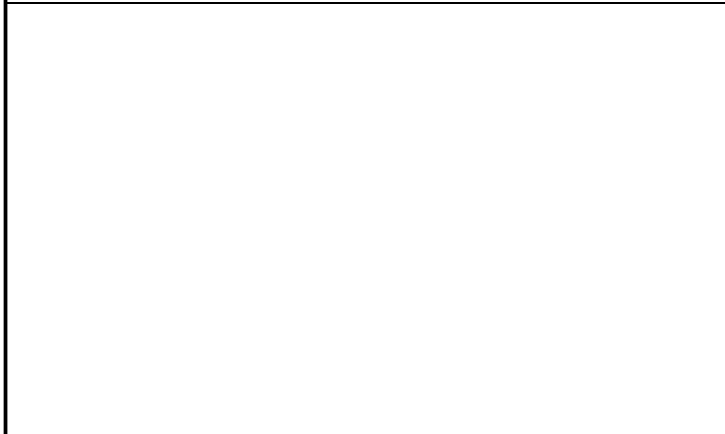
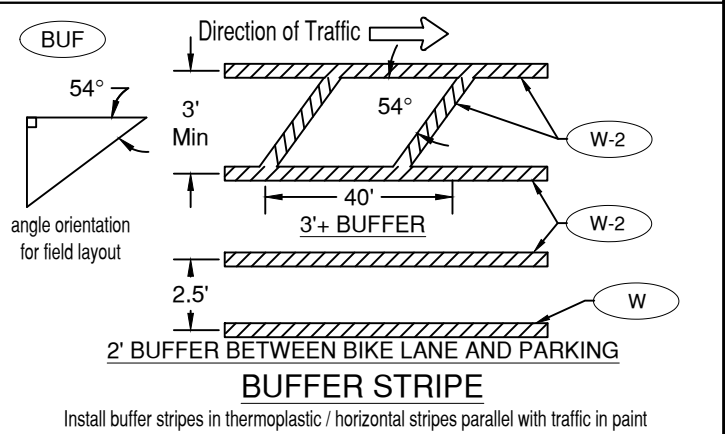
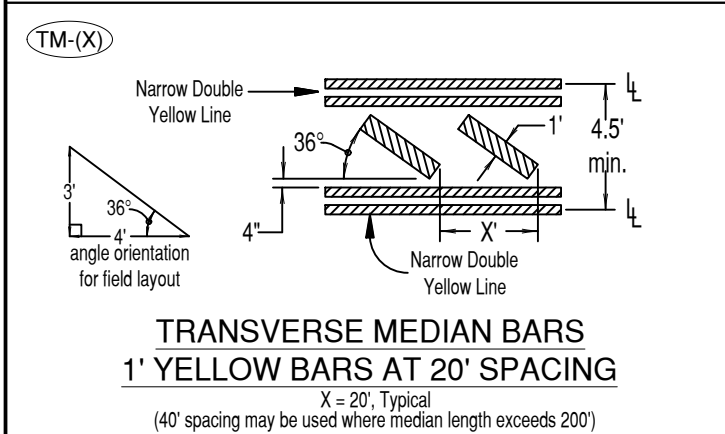
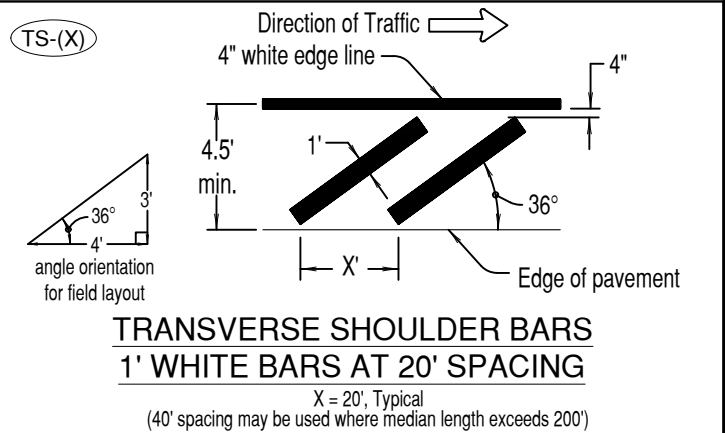
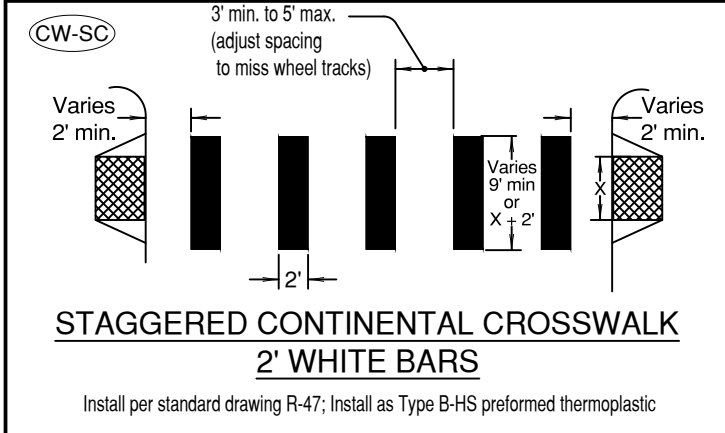
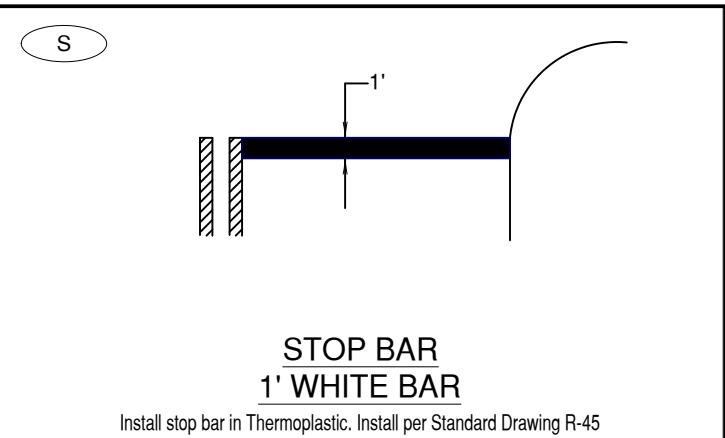
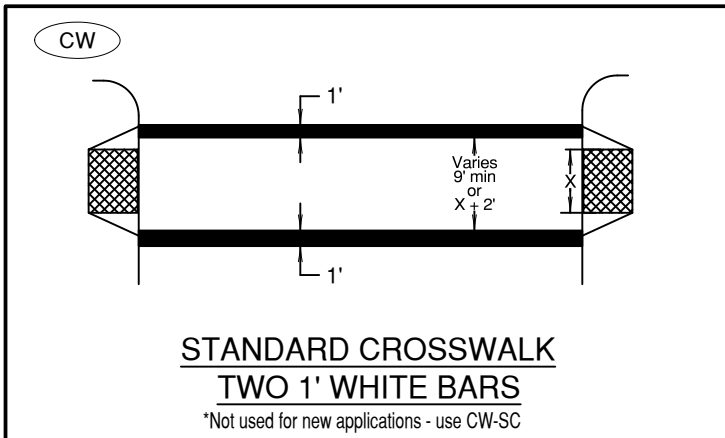

DRAWN AJD	
DIV ROADWAY	
REV	DATE



CITY OF BEND
STANDARD DRAWING
710 NW WALL ST., BEND, OREGON 97701

PAVEMENT MARKINGS

SCALE NTS
DATE 04/16/2026
APPR
STD DWG R-42A

ON

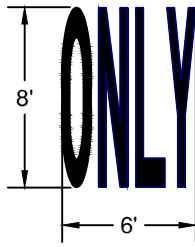

ONLY (white)

Center marking within lane width
Install in Type B - HS Preformed Thermoplastic
For letter proportion details, see current version of FHWA Standard Highway Signs

SCH

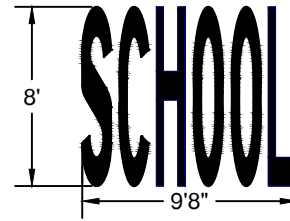

*For travel lanes <11' width,
use 6' tall x 8' wide stencil

SCHOOL (white)*

Center marking within lane width
Install in Type B - HS Preformed Thermoplastic
For letter proportion details, see current version of FHWA Standard Highway Signs
Install at school speed zone sign on arterial and collector roads

E-SA

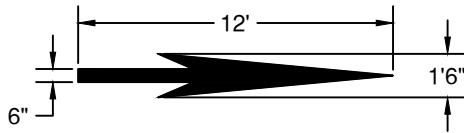

ELONGATED STRAIGHT ARROW (white)

For arrow proportion details, see current version of FHWA Standard Highway Signs
Install in Type B - HS Preformed Thermoplastic
Center marking within lane width

E-LA

E-RA

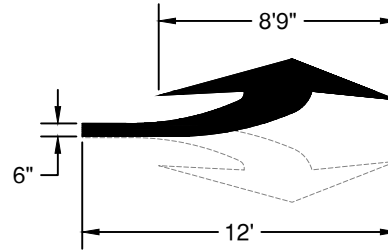

ELONGATED TURN ARROW (white)

For arrow proportion details, see current version of FHWA Standard Highway Signs
Install in Type B - HS Preformed Thermoplastic
Center marking within lane width
Use E-LA for Left Turn and E-RA for right turn.

E-LSA

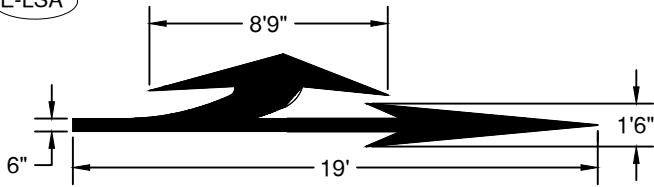

ELONGATED LEFT TURN STRAIGHT ARROW (white)

For arrow proportion details, see current version of FHWA Standard Highway Signs
Install in Type B - HS Preformed Thermoplastic
Center marking within lane width

E-RSA

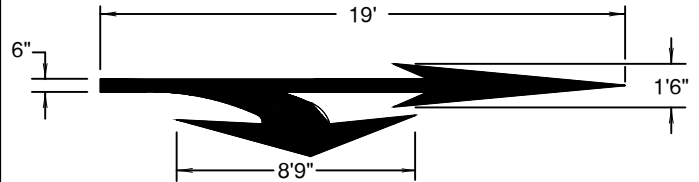

ELONGATED RIGHT TURN STRAIGHT ARROW (white)

For arrow proportion details, see current version of FHWA Standard Highway Signs
Install in Type B - HS Preformed Thermoplastic
Center marking within lane width

P

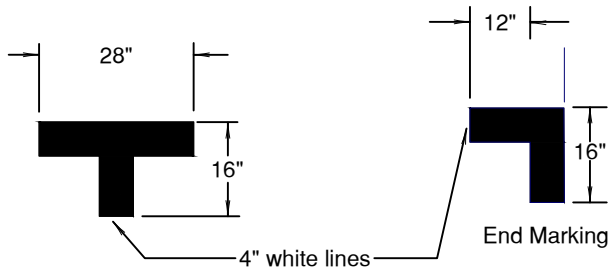

ON-STREET PARKING DETAIL (white)

SB

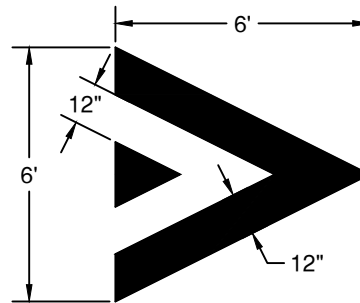

SPEED BUMP MARKING (WHITE)

Install in Type B - HS Preformed Thermoplastic
Center marking within lane width

DRAWN ARI
DIV ROADWAY
REV DATE



CITY OF BEND

STANDARD DRAWING

710 NW WALL ST., BEND, OREGON 97701

PAVEMENT MARKINGS

SCALE NTS

DATE 04/16/2026

APPR

STD DWG R-42B

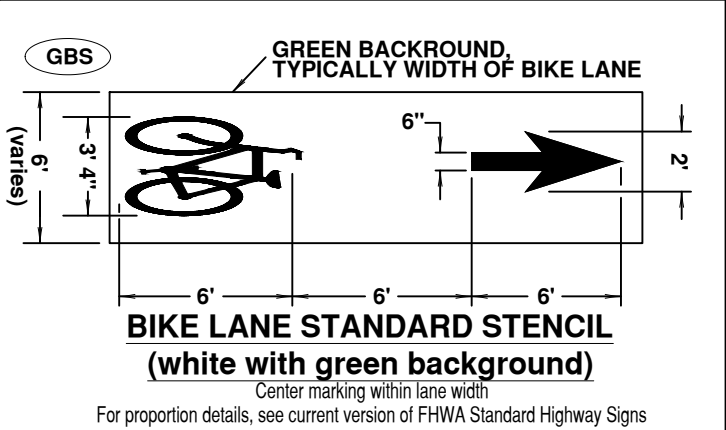
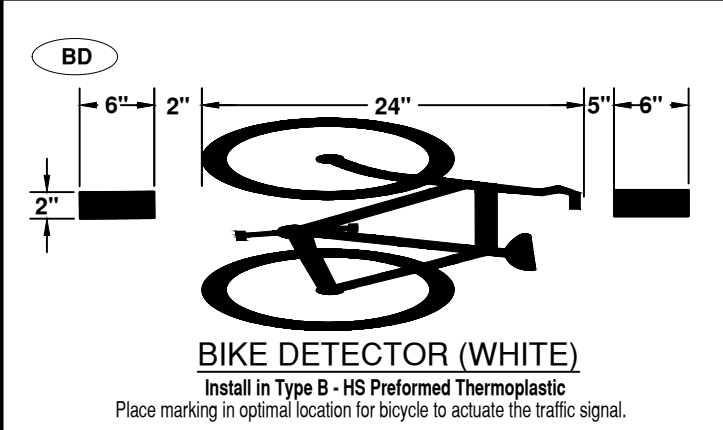
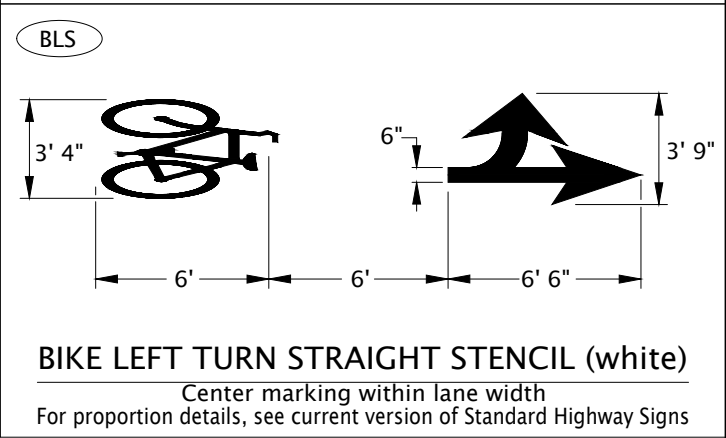
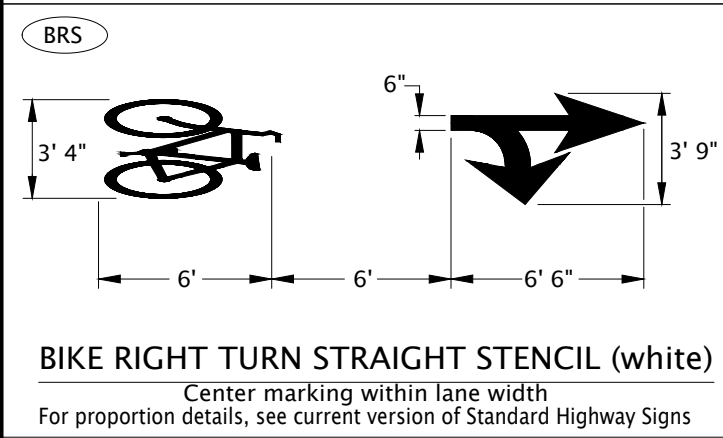
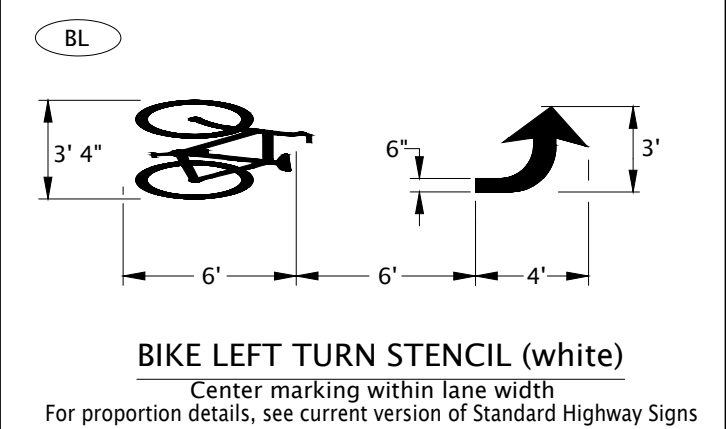
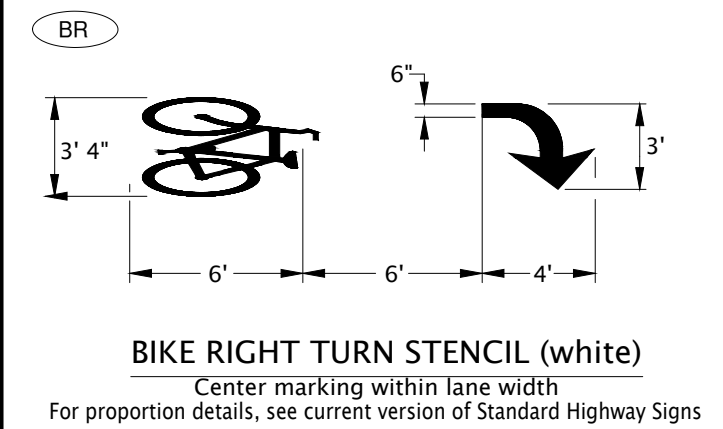
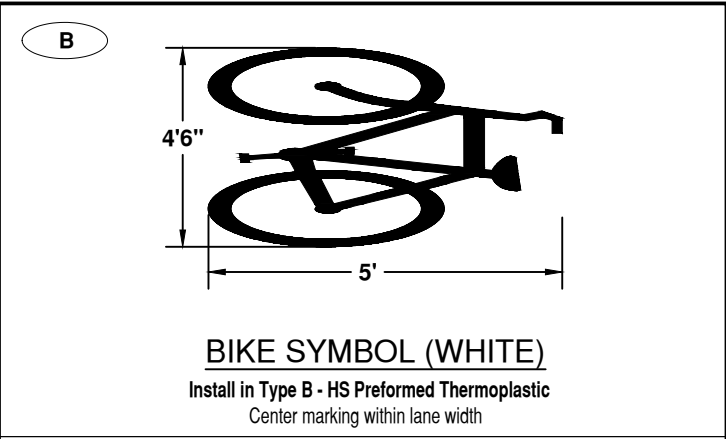
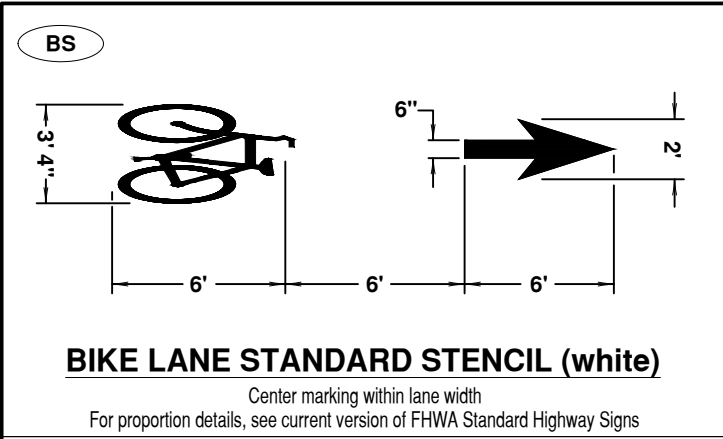

DRAWN ARI	
DIV ROADWAY	
REV	DATE



CITY OF BEND
STANDARD DRAWING
710 NW WALL ST., BEND, OREGON 97701

PAVEMENT MARKINGS - BIKE

SCALE NTS
DATE 04/16/2026
APPR
STD DWG R-43

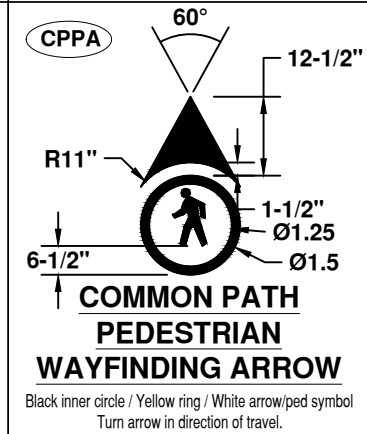
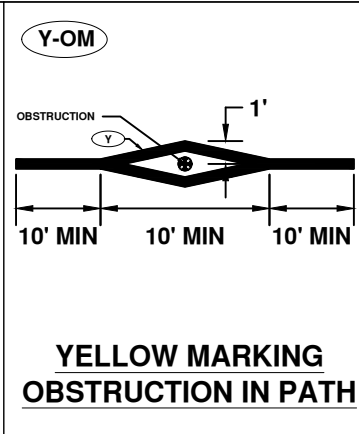
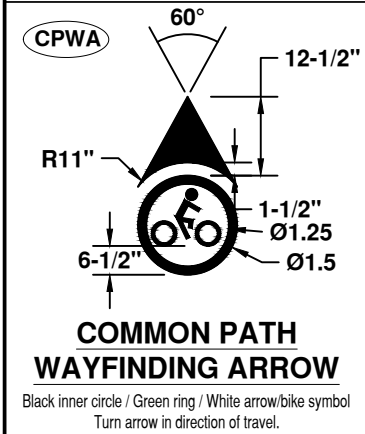
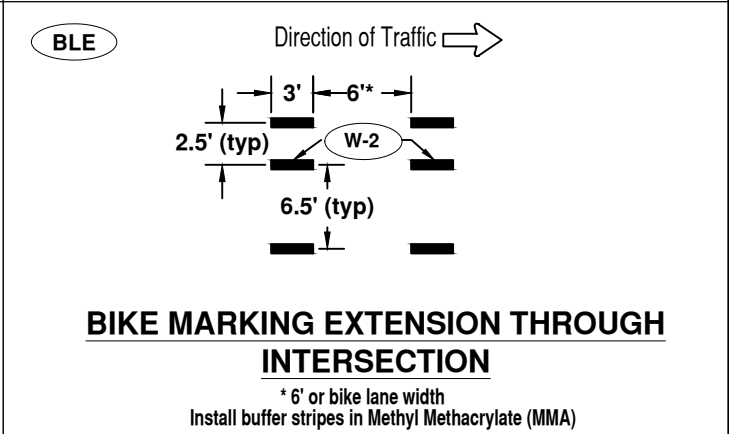
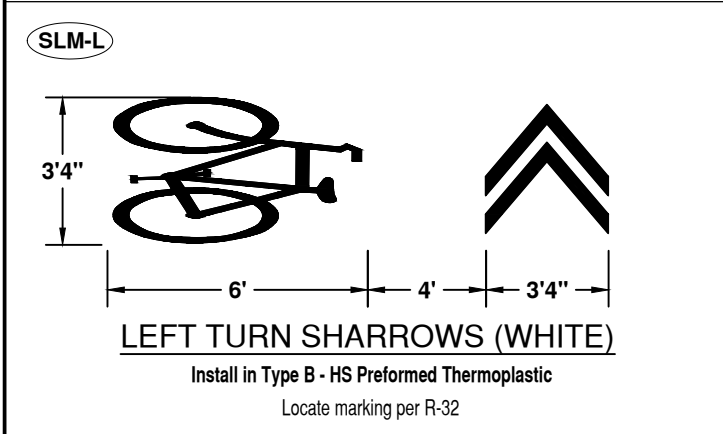
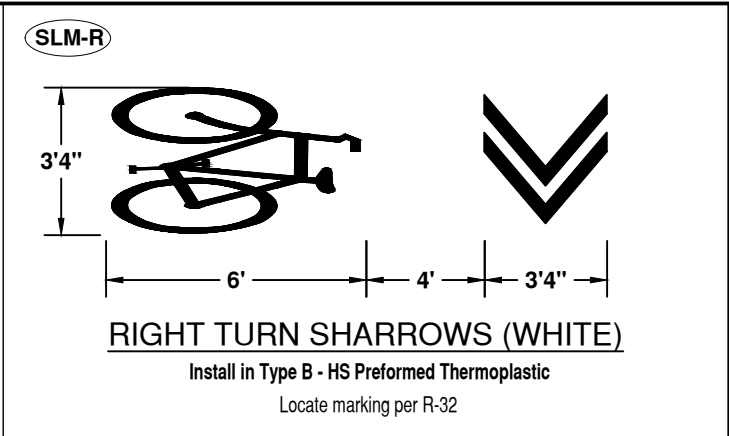
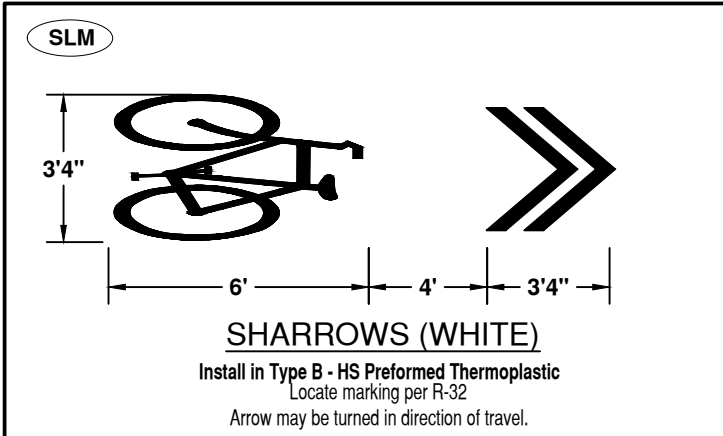

DRAWN ARI	
DIV ROADWAY	
REV	DATE



CITY OF BEND
 STANDARD DRAWING
 710 NW WALL ST., BEND, OREGON 97701

PAVEMENT MARKINGS - BIKE

SCALE NTS
DATE 04/16/2026
APPR
STD DWG R-43A

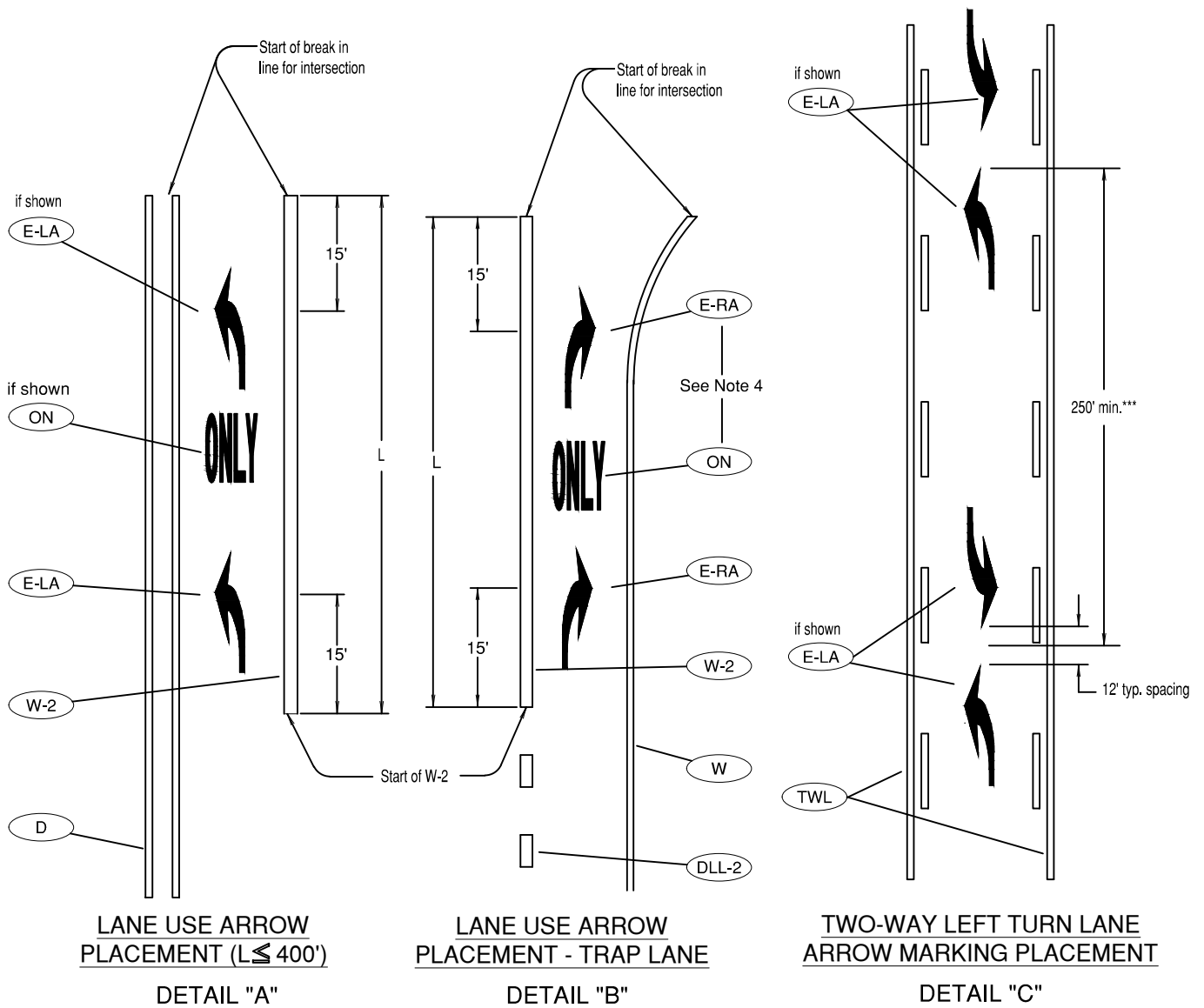

General Notes:

- 1.) Center pavement marking legends within the lane.
- 2.) Placement of lane use arrows with respect to the 8" wide white line (W-2) channelization shown in details "A", "B" and "C" apply to both left and right turn lanes.
- 3.) When used for a short turn lane (<40'), the 2nd (downstream) arrow may be omitted.
- 4.) An ONLY symbol is only required where a through lane approaching an intersection becomes a mandatory turn lane.

** When L is greater than 200', install 3rd lane use arrow at the midpoint of the turn lane.

To be accompanied by Standard Dwg. Nos. R-40 thru R-43

DRAWN	AJD
DIV	ROADWAY
REV	DATE



CITY OF BEND

CITY OF BEND
STANDARD DRAWING

710 NW WALL ST., BEND, OREGON 97701

TURN LANE MARKING LAYOUT

SCALE NTS

DATE 01/31/2022

APPR

STD DWG R-44

GRN

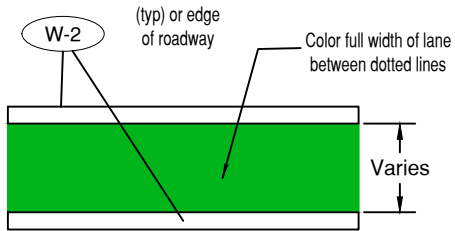

**GREEN SUPPLEMENTED BICYCLE LANE
SOLID LANE**

BLE-G

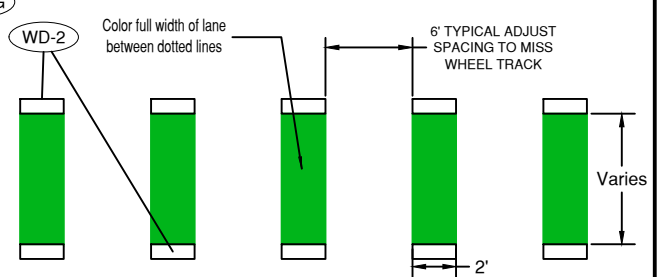

**GREEN SUPPLEMENTED BICYCLE LANE
DOTTED LINE EXTENSION**

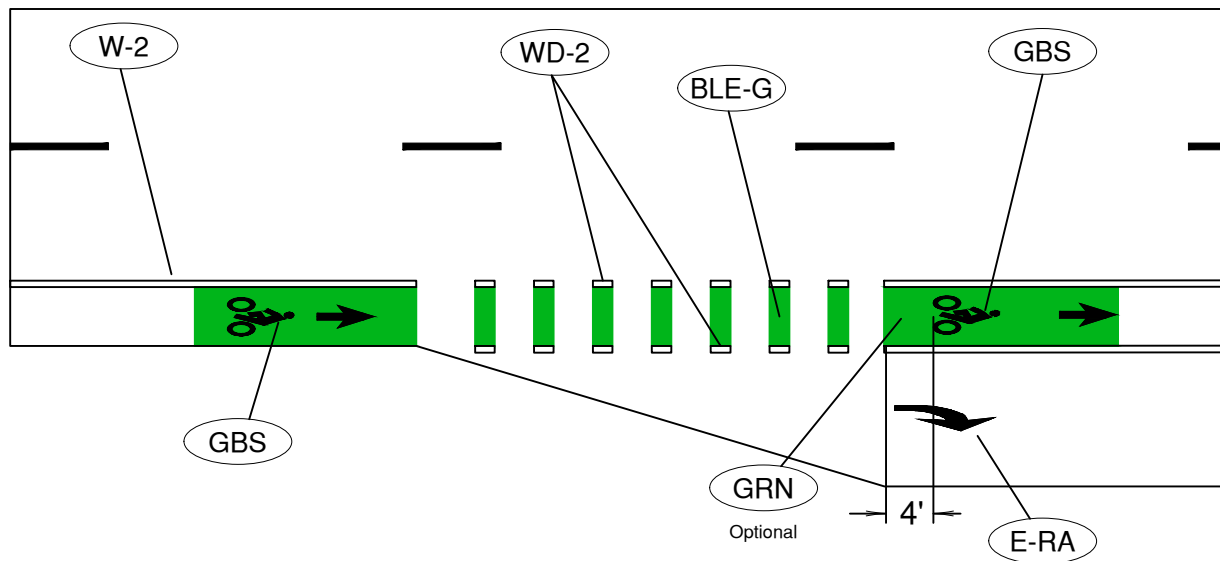

TYPICAL GREEN SUPPLEMENTED BICYCLE LANE ACROSS AN ADDED RIGHT TURN LANE TAPER

NOTES:

1. GREEN PAVEMENT MARKING USE PER DESIGN STANDARDS WITH CITY ENGINEER APPROVAL

DRAWN	AJD
DIV	ROADWAY
REV	DATE



CITY OF BEND

CITY OF BEND

STANDARD DRAWING

710 NW WALL ST., BEND, OREGON 97701

INTERSECTION BIKE SAFETY

SCALE NTS

DATE 11/01/2024

APPR

STD DWG R-44A

General Notes:

1. Where a curb clearly defines the roadway edge in the taper area, the edge line shown may be omitted in the taper area as determined by engineer judgement.
2. Motor vehicle speed adjacent to bicycle lane.

POSTED OR 85TH PERCENTILE SPEED (MPH) ²	d (FT)	L (ft)
20	128	L=WS
25	152	
30	176	
35	184	
40	192	
45+	200	

WHERE:

L = taper length
 W = width of bicycle lane being reduced (ft)
 S = vehicle speed (mph)
 "d" distances are for level roads.
 Corrections should be made for grades.

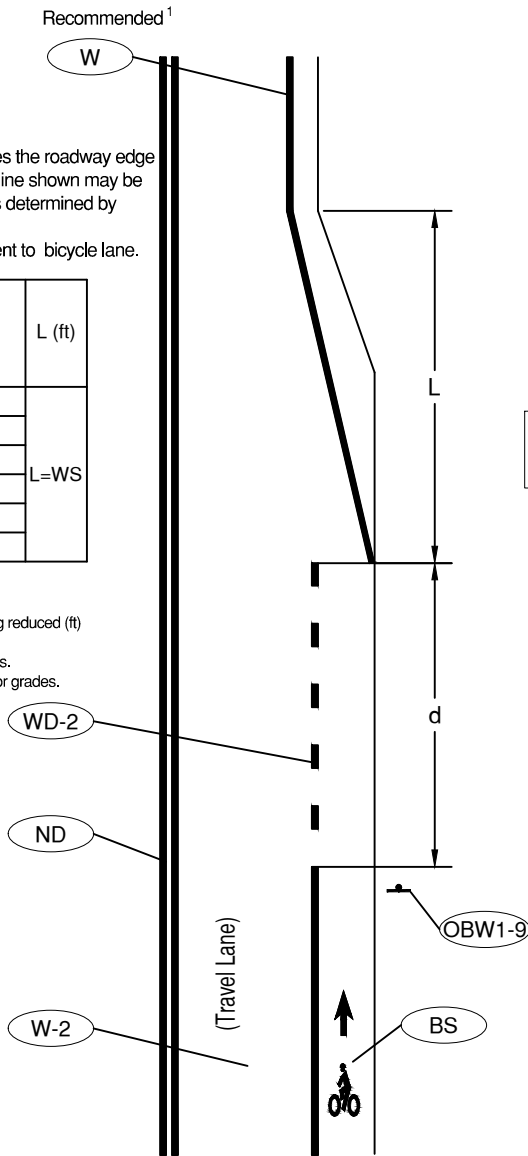

END OF BIKE LANE

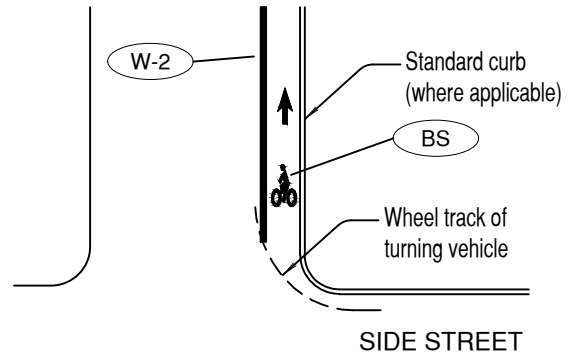

General Note:

Install bike lane stencil to avoid right turning vehicle wheel tracks.

INSTALLATION OF BIKE LANE STENCILS
FOLLOWING INTERSECTIONS

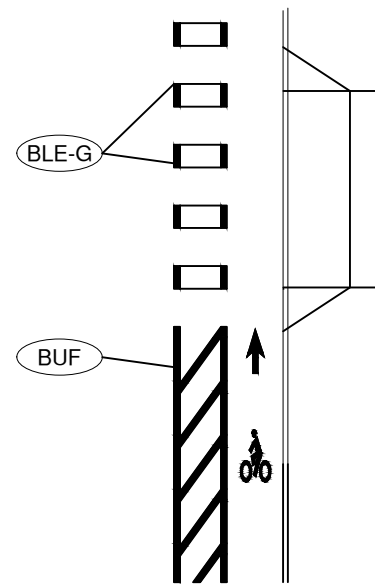

BUFFER BIKE LANE
IN CONFLICT AREA
 (FOR HIGH VOLUME COMMERCIAL DRIVEWAYS)

To be accompanied by Standard Dwg. Nos. R-40 thru R-43 and R-44A

DRAWN	AJD
DIV	ROADWAY
REV	DATE



CITY OF BEND

CITY OF BEND

STANDARD DRAWING

710 NW WALL ST., BEND, OREGON 97701

BIKE LANE MARKINGS

SCALE NTS

DATE 11/01/2024

APPR

STD DWG R-44B

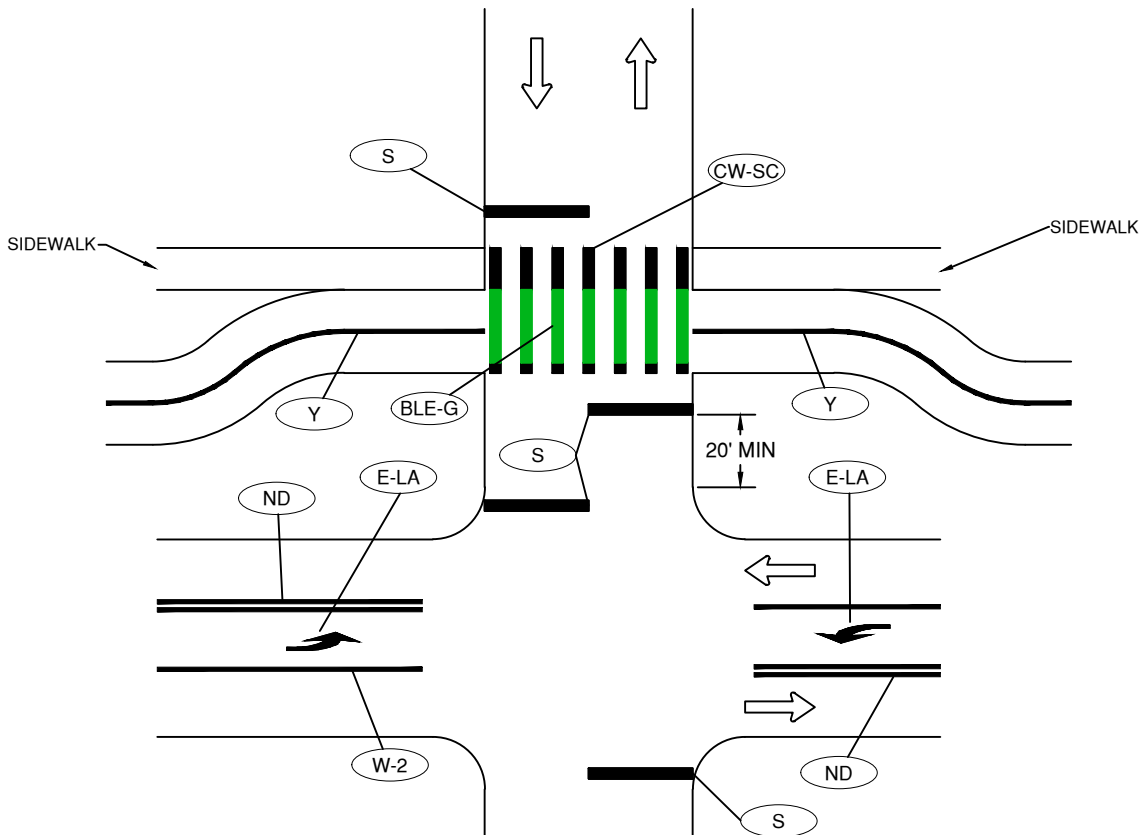

Typical 2-way separated marked bicycle crossing where path offset from street

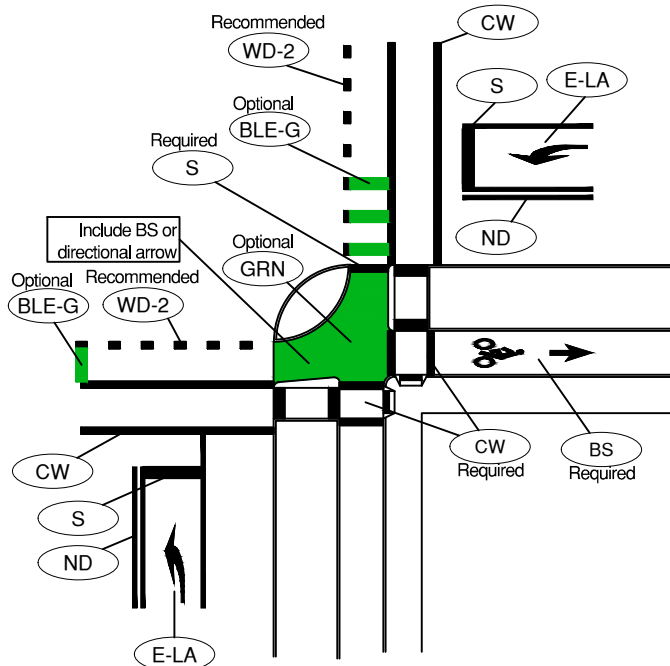

Example separated bicycle lane markings at a signalized intersection

DRAWN AJD	
DIV ROADWAY	
REV	DATE



CITY OF BEND
 STANDARD DRAWING
 710 NW WALL ST., BEND, OREGON 97701
BIKE LANE MARKINGS

SCALE NTS
DATE 11/01/2024
APPR
STD DWG R-44C

1) Stop bar required at stop control approaches on arterials and collector streets

* Stop bar shall be placed as near as possible to the intersecting traveled way. Locate stop bar 4' min. to 30' max. in advance of the extended fog line, edge of pavement, or curb face. Minimum stop bar distance may need to be increased, depending on location of pedestrian ramps (see Detail "A") and/or vehicle turn radii (see Detail "B"). Field verify sight distance and truck turning movements. Stop bar not required at local/local intersections.

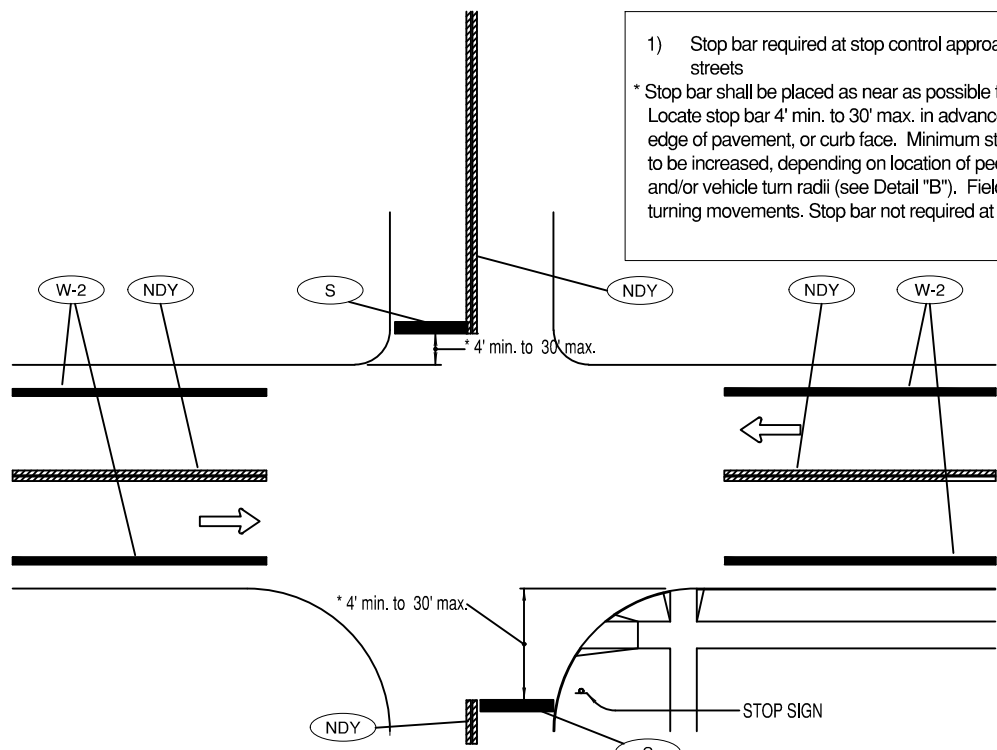

PAVEMENT MARKINGS FOR TYPICAL INTERSECTION

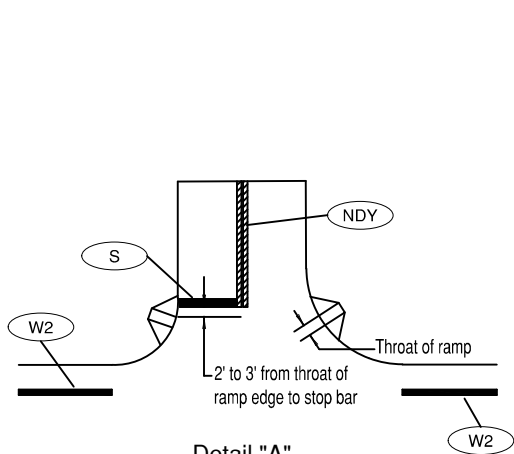

Detail "A"
STOP BAR PLACEMENT WITH RESPECT TO PEDESTRIAN RAMP

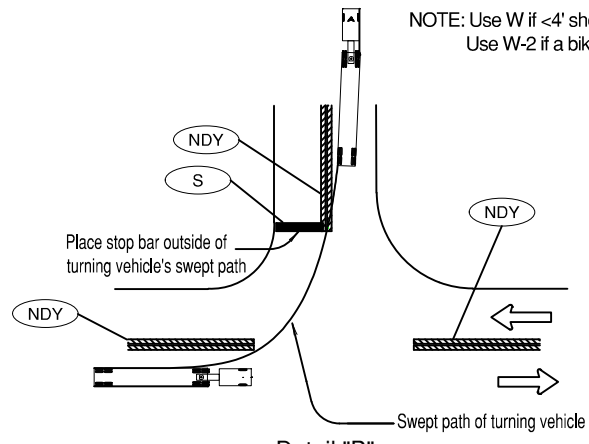

Detail "B"
STOP BAR PLACEMENT WITH RESPECT TO TURN RADI WHERE NO RAMP

NOTE: Use W if <4' shoulder (no bike lane). Use W-2 if a bike lane exists.

To be accompanied by Standard Dwg. Nos. R-40 thru R-43

DRAWN AJD	
DIV ROADWAY	
REV	DATE



CITY OF BEND
STANDARD DRAWING
710 NW WALL ST., BEND, OREGON 97701

INTERSECTION PAVEMENT MARKING LAYOUT

SCALE NTS
DATE 01/31/2022
APPR
STD DWG R-45

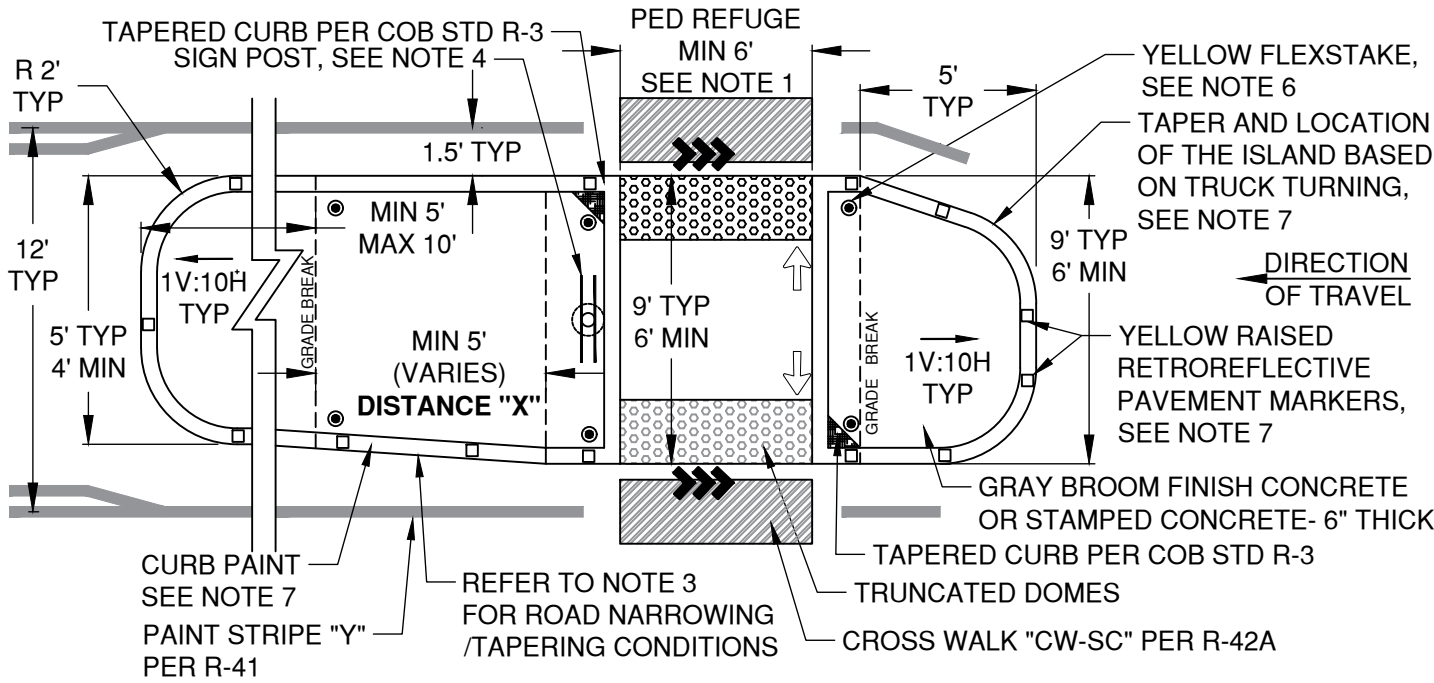

5.0% MAX (4.5% DESIGN) AT NON-STOP CONTROLLED INTERSECTION - 0.5% MIN
 2.0% TYPICAL

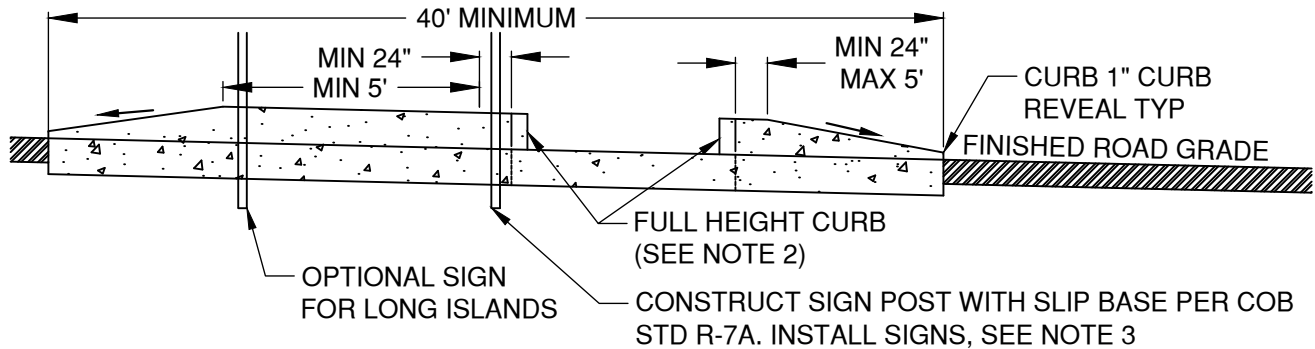

R4-7



R1-6A

NOTE: SEE STANDARD DRAWING R46.1 FOR PEDESTRIAN REFUGE ISLAND NOTES

DRAWN ARI	
DIV ROADWAY	
REV	DATE



CITY OF BEND
 STANDARD DRAWING
 710 NW WALL ST., BEND, OREGON 97701
PEDESTRIAN REFUGE ISLAND

SCALE NTS
DATE 04/16/2026
APPR
STD DWG R-46

NOTES:

1. PEDESTRIAN REFUGE OPENING TO MATCH THE WIDTH OF THE CURB RAMPS OR SIDEWALKS COMING INTO THE INTERSECTION, BUT NOT LESS THAN 6 FEET WIDE.
2. INSTALL CURB PER CITY STANDARD R-3. FULL HEIGHT CURB (DEPENDENT ON THE STREET CLASSIFICATION) OUTSIDE THE BULL NOSE / VERTICAL TAPER SECTIONS OF THE ISLAND.
3. TAPER TO BE $\frac{1}{2} \times X$ OR AS NEEDED TO TERMINATE THE ISLAND WITH A 4' MIN BULLNOSE.
4. INSTALL R1-6A AND R4-7 (R1-6A OR R1-6C SIGNS FOR SCHOOL ZONES) SIGNS BACK TO BACK ON SIGN POST ADJACENT TO THE PED REFUGE. INSTALL AN ADDITIONAL POST PER COB STANDARD R-7A FOR INSTALLATION OF A SECOND R4-7 SIGN IF THE ISLAND EXCEEDS 40 FEET IN TOTAL LENGTH, OR AS DIRECTED BY THE CITY ENGINEER.
5. ISLANDS ARE NOT TO BE DOWELED INTO ROADWAYS UNLESS APPROVED BY THE CITY ENGINEER.
6. INSTALL 36" YELLOW TUBULAR FLEXSTAKE TM 750, OR APPROVED EQUAL, WITH TWO REFLECTIVE STRIPS DELINEATOR ON THE END OF THE BULLNOSE. OFFSET TO AVOID BLOCKING THE R1-6A SIGN. USE CONCRETE ANCHORS (REDHEAD OR EQUIVALENT).
7. INSTALL RETROREFLECTIVE YELLOW PAVEMENT MARKERS ON TOP OF CURB AT 3' MAX SPACING AROUND MEDIAN NOSE AND AT 15' SPACING TO AND BEYOND TAPER SECTION AS SHOWN. INSTALL RETROREFLECTIVE YELLOW CURB PAINT ON CURB TO LIMIT OF PAVEMENT MARKERS.
8. PLACEMENT OF ISLAND WILL BE BASED ON A WB-50 TURNING TEMPLATE. LARGER RADII MAY BE REQUIRED BY CITY ENGINEER TO FIT CONTEXT, SUCH AS INDUSTRIAL OR RESIDENTIAL AREA.

DRAWN ARI		 CITY OF BEND	CITY OF BEND STANDARD DRAWING 710 NW WALL ST., BEND, OREGON 97701	SCALE NTS
DIV ROADWAY				DATE 04/16/2026
REV	DATE			APPR
			PEDESTRIAN REFUGE ISLAND NOTES	STD DWG R-46.1

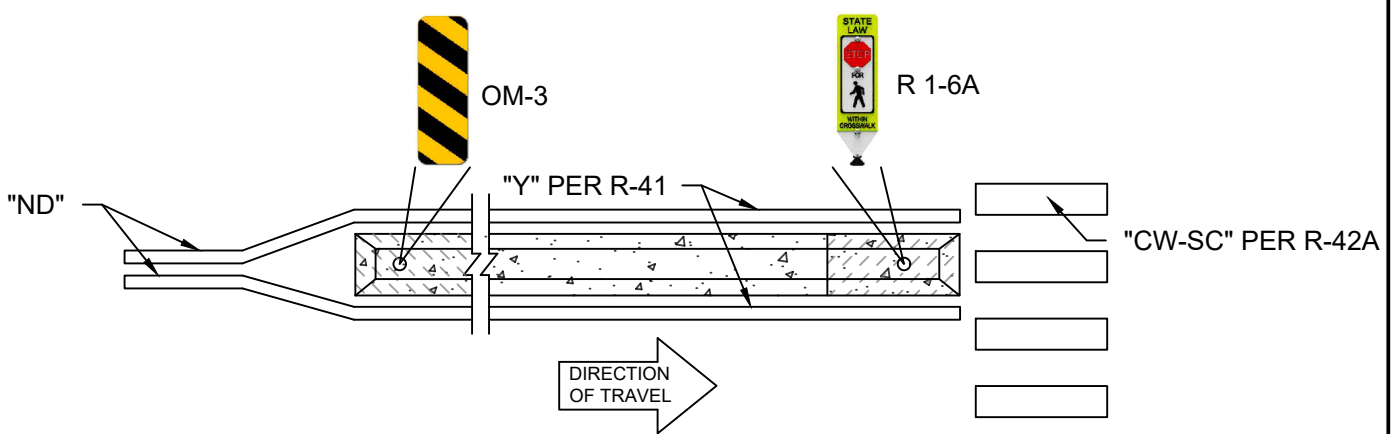
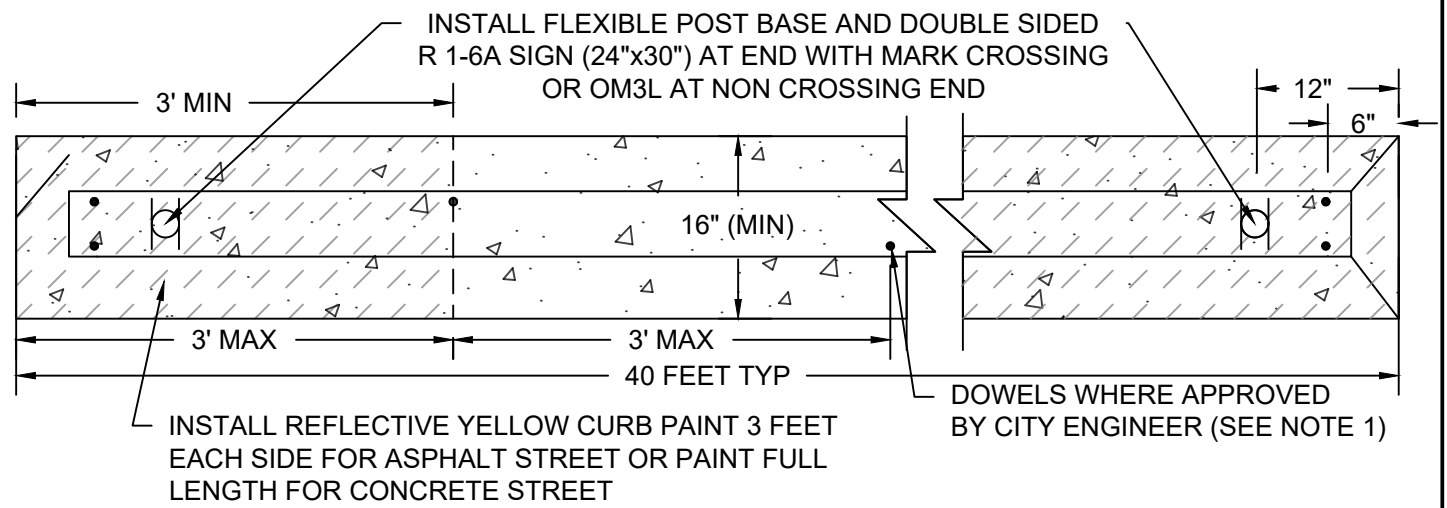
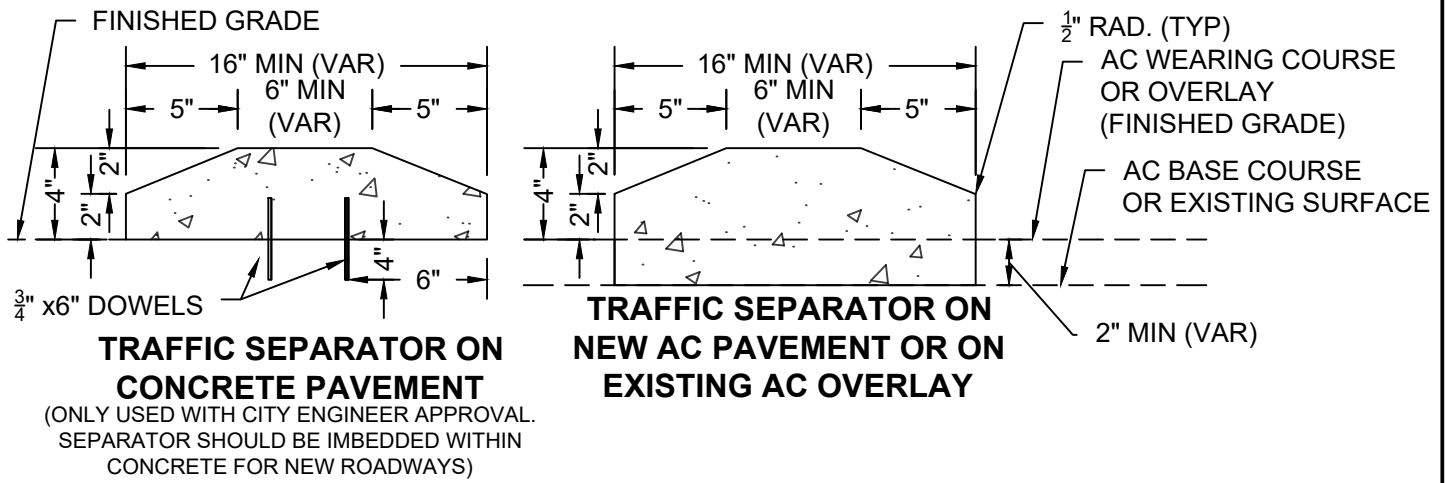

TRAFFIC SEPARATOR WITH STRIPING AND SIGNS

NOTE: SEE STANDARD DRAWING R46A.1 FOR TRAFFIC SEPARATOR NOTES

DRAWN AJD DIV ROADWAY REV DATE		CITY OF BEND STANDARD DRAWING 710 NW WALL ST., BEND, OREGON 97701	SCALE NTS DATE 04/16/2026 APPR STD DWG R-46A
		TRAFFIC SEPARATOR	

NOTES:

1. DOWELS TO BE USED IN LIMITED CASES WERE APPROVED BY THE CITY ENGINEER (TEMPORARY INSTALLATIONS OR WHERE THE SEPARATOR IS SHORT AND MAY NOT HAVE SUBSTANTIAL WEIGHT TO KEEP IN PLACE). WHEN DOWELS ARE APPROVED, THEY MUST BE 3/4" DIAMETER WITH LENGTH EXTENDING A MINIMUM 6" BELOW THE BOTTOM OF THE SEPARATOR. DOWELS TO BE SET BEFORE CONCRETE HARDENS.
2. TRANSVERSE JOINTS IN CONCRETE TRAFFIC SEPARATORS AND TRANSITIONS TO MATCH JOINTS IN CONCRETE PAVEMENT AND TO BE OF SAME TYPE.
3. SET JOINT SPACING 200' MAX FOR EXPANSION AND 15' MAX FOR CONTRACTION.
4. SITE CONDITIONS MAY REQUIRE A PROJECT SPECIFIC DRAIN OPENING WHICH CONSIDERS ROADWAY CONDITIONS (SHEET FLOW LIMITS, CROSS SLOPE, SUPER ELEVATION, ETC). WHERE BREAKS ARE REQUIRED IN THE SEPARATOR, THE OPENS MUST BE 12".
5. PLACE APPROVED PREFORMED FILLER ALONG ONE SIDE OF THE CONC. TRANSITIONS IN CONCRETE PAVEMENT AND AROUND ALL CURBED POINTS. WHERE SEPARATOR IS INSTALLED WITHIN ASPHALT, APPLY TACK COATS TO CONCRETE PRIOR TO PAVING.

DRAWN AJD		 CITY OF BEND	CITY OF BEND STANDARD DRAWING 710 NW WALL ST., BEND, OREGON 97701	SCALE NTS
DIV ROADWAY				DATE 4/16/2026
REV	DATE		APPR	STD DWG R-46A.1
			TRAFFIC SEPARATOR NOTES	

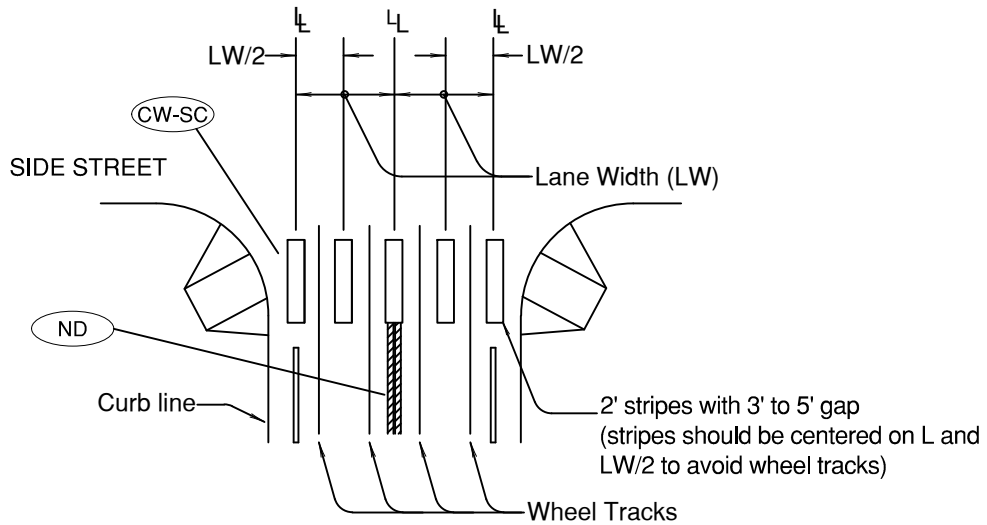

STAGGERED CONTINENTAL LAYOUT

General Note:

1. Install crosswalk bars such that the throat of the ADA ramp is entirely within crosswalk markings, or 5' back of extended fog line, edge of pavement, or curb face.

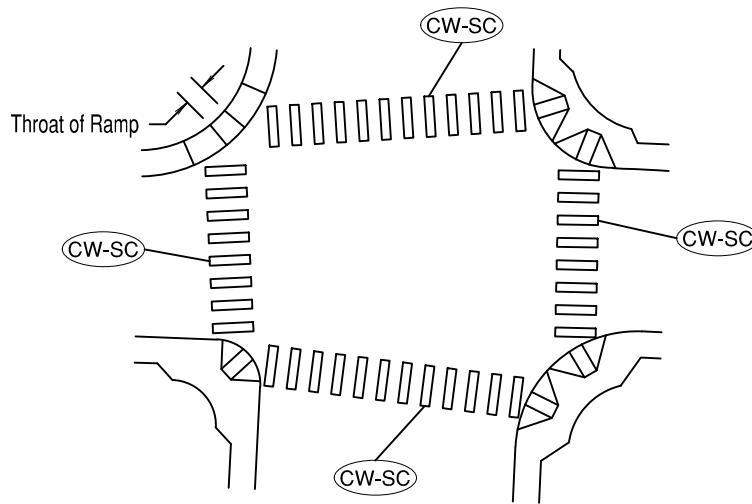

**STANDARD CROSSWALK MARKING
AT 4-WAY CONTROLLED
INTERSECTION**

To be accompanied by Standard Dwg. Nos. R-40 thru R-43

DRAWN ARI	
DIV ROADWAY	
REV	DATE



CITY OF BEND

CITY OF BEND

STANDARD DRAWING

710 NW WALL ST., BEND, OREGON 97701

CROSSWALK MARKINGS

SCALE NTS

DATE 04/16/2026

APPR

STD DWG R-47

TRANSITION AT EDGE WITH NATIVE
TOPSOIL AND NATIVE GRASS SEED
SUITABLE TO THE SITE

PAVED TRAIL
3" ASPHALT 4" BASE COURSE OF
5/8" MINUS AGGREGATE.

CROSS SLOPE PATH TO
DRAIN AT 1.5%

IF TRAIL IS USED AS
SERVICE ACCESS, INCREASE
PAVING THICKNESS

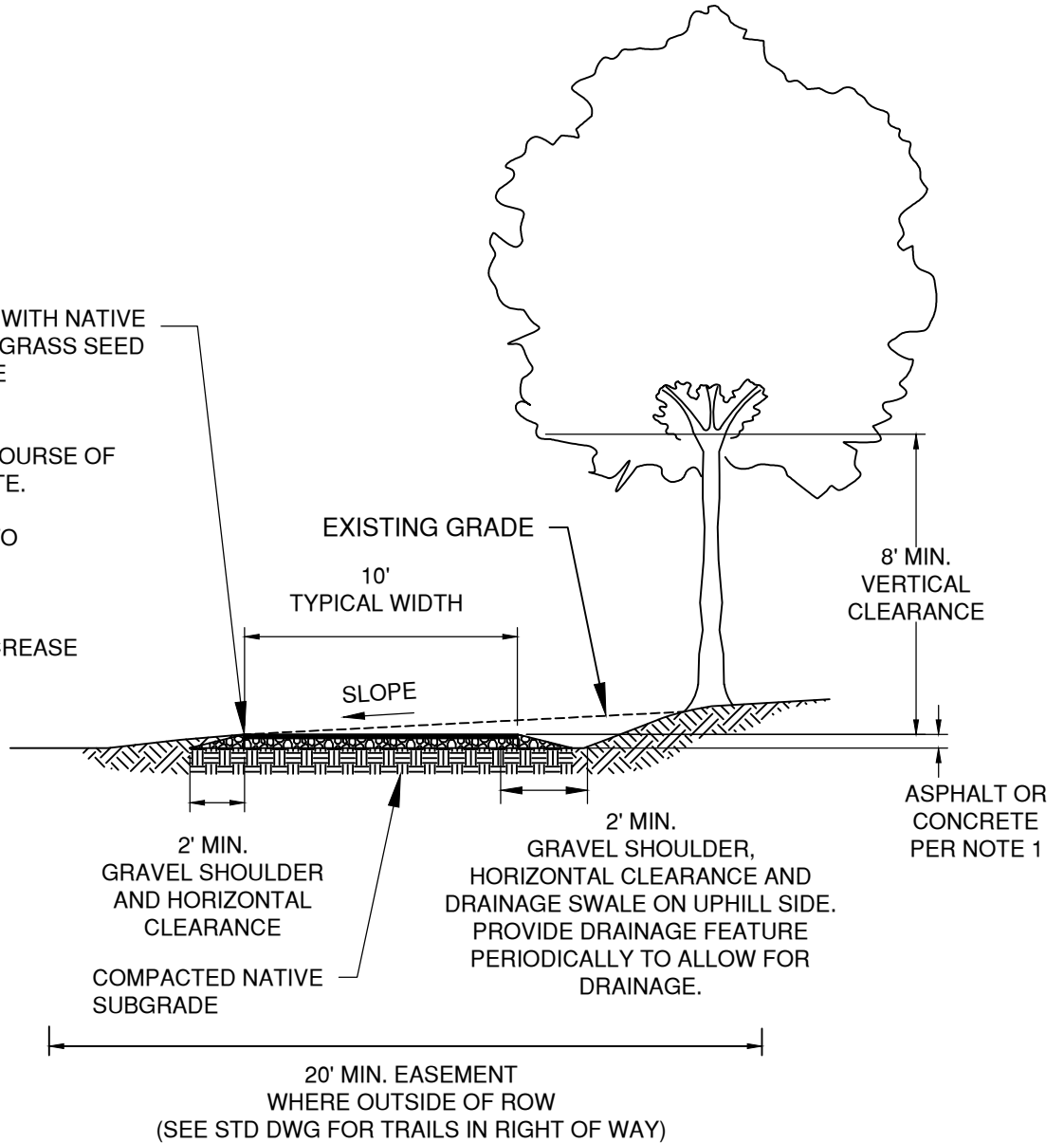

NOTES:

1. PRIMARY TRAIL SHALL BE PAVED WITH ASPHALT OR CONCRETE IN THE RIGHT-OF-WAY OR ADJACENT TO STREETS. OUTSIDE OF THE RIGHT-OF-WAY TRAIL MAY BE AGGREGATE AS APPROVED.
2. PRIMARY TRAILS ARE TYPICALLY FACILITIES OUTSIDE OF THE PUBLIC RIGHT-OF-WAY THAT ARE OWNED AND MAINTAINED BY THE BEND PARKS AND RECREATION DISTRICT OR PRIVATELY. (SEE STANDARD CROSS-SECTIONS FOR CITY SHARED USE PATHS IN THE RIGHT-OF-WAY.)
3. WHERE OUTSIDE OF RIGHT-OF-WAY, TRAIL EASEMENT DEDICATION IS REQUIRED INCLUDING A PUBLIC ACCESS EASEMENT AND UTILITY EASEMENT WHERE APPLICABLE.
4. TRAIL ALIGNMENTS ARE ENCOURAGED TO MEANDER AND NOT BE DESIGNED AS FENCED CANYONS.
5. TRAILS WITHIN RIGHT-OF-WAY SHALL MEET PROWAG REQUIREMENTS. TRAILS OUT OF RIGHT-OF-WAY SHALL MEET THE REQUIREMENTS OF THE UNITED STATES ACCESS BOARD ACCESSIBILITY STANDARDS FOR FEDERAL OUTDOOR DEVELOPED AREAS.

DRAWN AJD	
DIV ROADWAY	
REV	DATE



CITY OF BEND

CITY OF BEND

STANDARD DRAWING

710 NW WALL ST., BEND, OREGON 97701

PRIMARY TRAIL

SCALE NTS

DATE 01/31/2022

APPR

STD DWG R-48

TRANSITION AT EDGE WITH NATIVE TOPSOIL AND NATIVE GRASS SEED SUITABLE TO THE SITE

PAVED TRAIL
2.5" ASPHALT 4" BASE COURSE OF 5/8" MINUS AGGREGATE

AGGREGATE TRAIL
2" TOP COURSE OF 3/8" MINUS COMPACTED 4" BASE COURSE OF 5/8" MINUS COMPACTED

CROSS SLOPE PATH TO DRAIN AT 1.5%

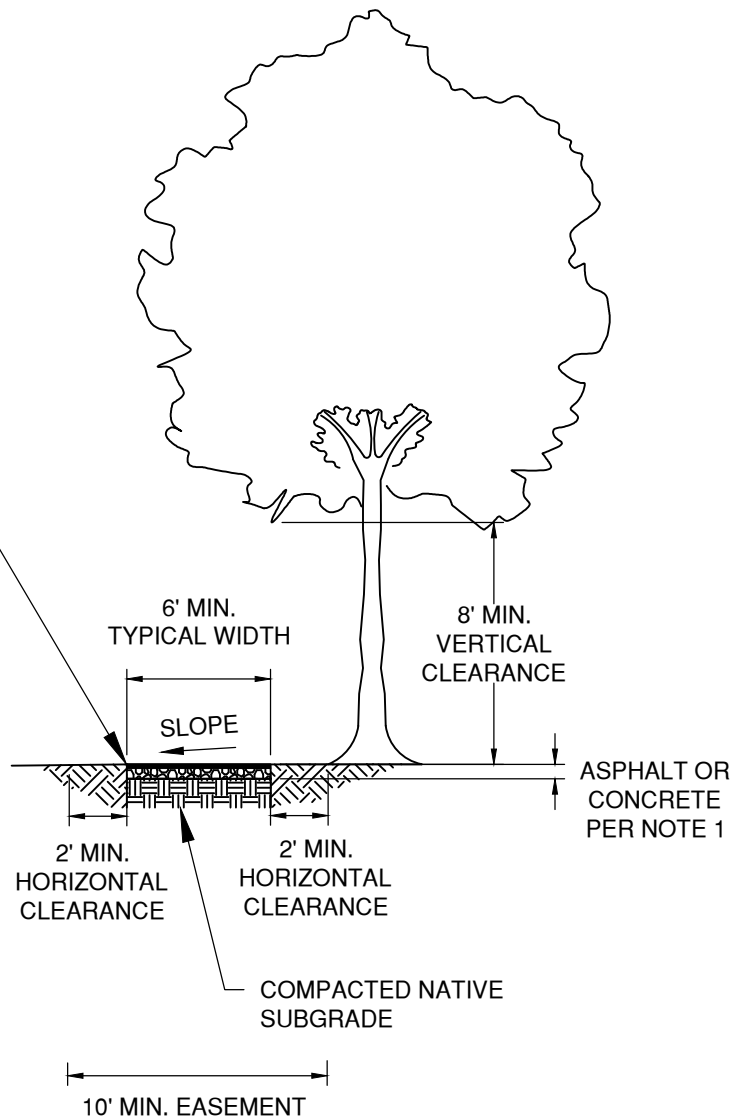

NOTES:

- CONNECTOR TRAIL SHALL BE PAVED WITH ASPHALT OR CONCRETE IN THE RIGHT-OF-WAY OR ADJACENT TO STREETS. OUTSIDE OF THE RIGHT-OF-WAY TRAIL MAY BE AGGREGATE AS APPROVED.
- CONNECTOR TRAILS ARE TYPICALLY FACILITIES OUTSIDE OF THE PUBLIC RIGHT-OF-WAY THAT ARE OWNED AND MAINTAINED BY THE BEND PARKS AND RECREATION DISTRICT OR PRIVATELY. (SEE STANDARD CROSS-SECTIONS FOR CITY SHARED USE PATHS IN THE RIGHT-OF-WAY.)
- WHERE OUTSIDE OF RIGHT-OF-WAY, TRAIL EASEMENT DEDICATION IS REQUIRED INCLUDING A PUBLIC ACCESS EASEMENT AND UTILITY EASEMENT WHERE APPLICABLE.
- TRAIL ALIGNMENTS ARE ENCOURAGED TO MEANDER AND NOT BE DESIGNED AS FENCED CANYONS.
- NATIVE SURFACE TRAILS MAY BE USED WITHIN PARKS OR PRIVATE DEVELOPMENTS TO PROVIDE CONNECTIONS TO PRIMARY AND OTHER CONNECTOR TRAILS.
- TRAILS WITHIN RIGHT-OF-WAY SHALL MEET PROWAG REQUIREMENTS. TRAILS OUT OF RIGHT-OF-WAY SHALL MEET THE REQUIREMENTS OF THE UNITED STATES ACCESS BOARD ACCESSIBILITY STANDARDS FOR FEDERAL OUTDOOR DEVELOPED AREAS AT A MINIMUM.

DRAWN AJD	
DIV ROADWAY	
REV	DATE



CITY OF BEND

CITY OF BEND

STANDARD DRAWING

710 NW WALL ST., BEND, OREGON 97701

CONNECTOR TRAIL

SCALE NTS

DATE 01/31/2022

APPR

STD DWG R-49

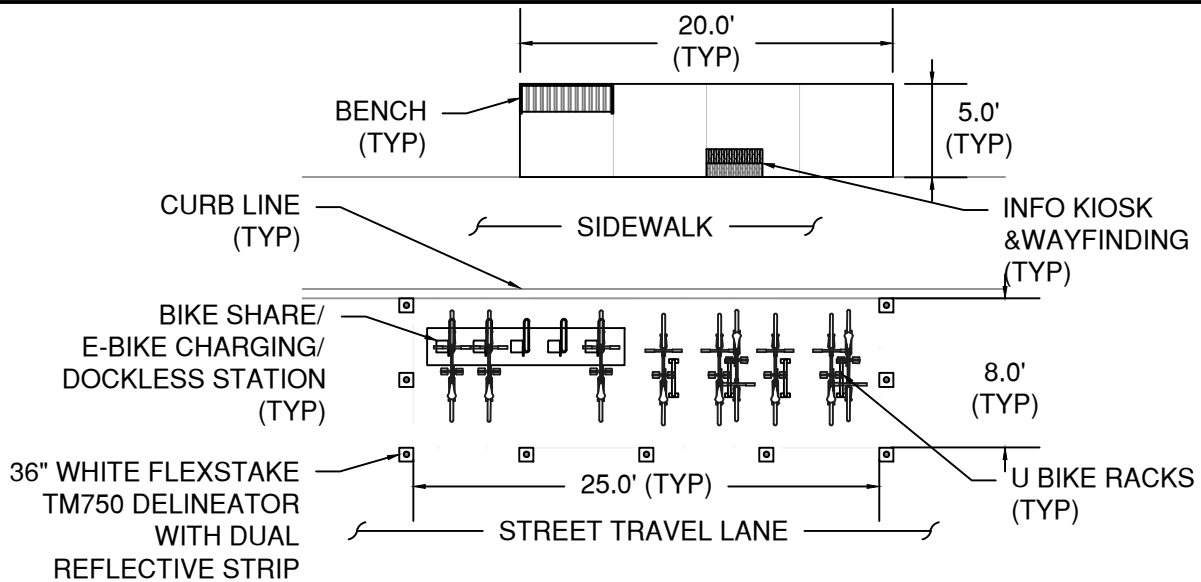

SMALL MOBILITY POINT

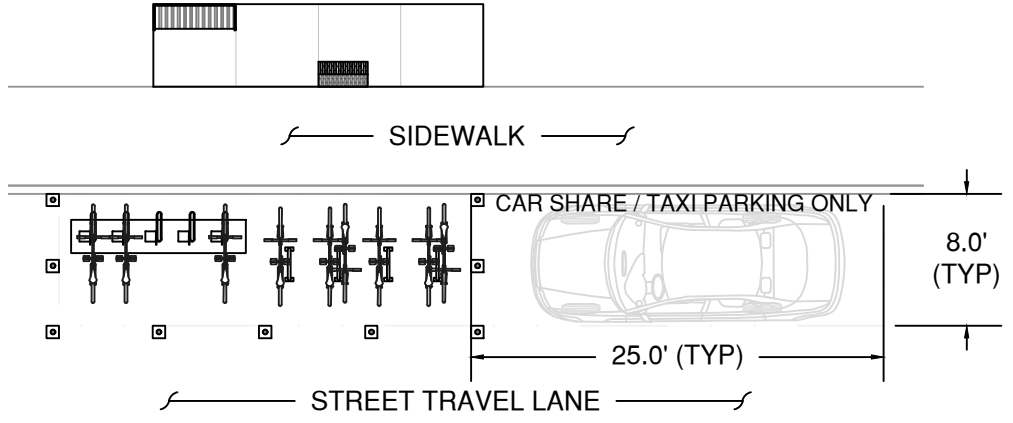

MEDIUM MOBILITY POINT

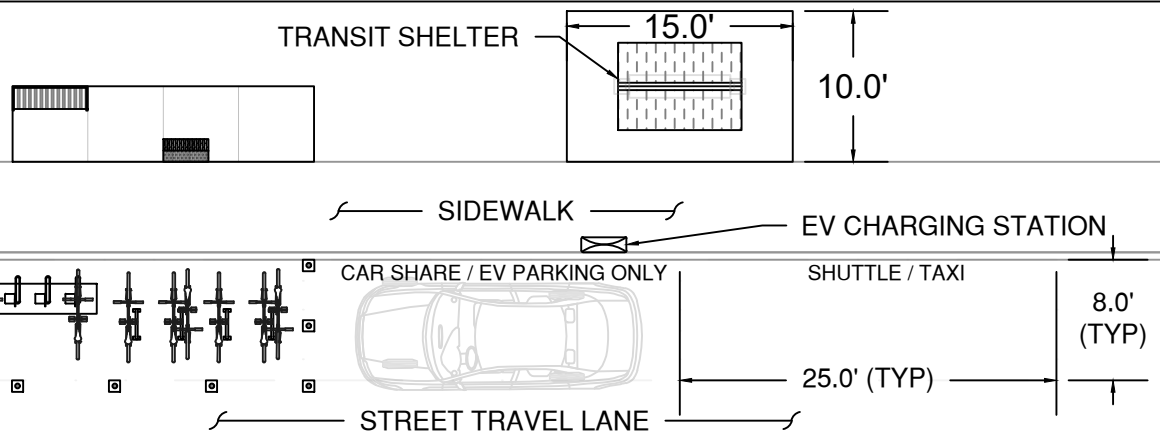

MEDIUM (+) MOBILITY POINT

- NOTES:
1. LOCATION & EXISTING CONDITIONS WILL DETERMINE LAYOUT
 2. FINAL LAYOUT MUST MEET MINIMUM ADA STANDARDS FOR ACCESSIBLE DESIGN
 3. ALL CONCEPTS SHOWN ARE FOR SPATIAL REPRESENTATION ONLY
 4. BICYCLE PARKING STATIONS MAY BE PLACED WITH IN ON-STREET PARKING SPACES OR ON PRIVATE PROPERTY

DRAWN AJD	
DIV ROADWAY	
REV	DATE



CITY OF BEND
STANDARD DRAWING
710 NW WALL ST., BEND, OREGON 97701

MOBILITY POINTS - SMALL/MEDIUM

SCALE NTS
DATE 11/01/2024
APPR
STD DWG R-50A

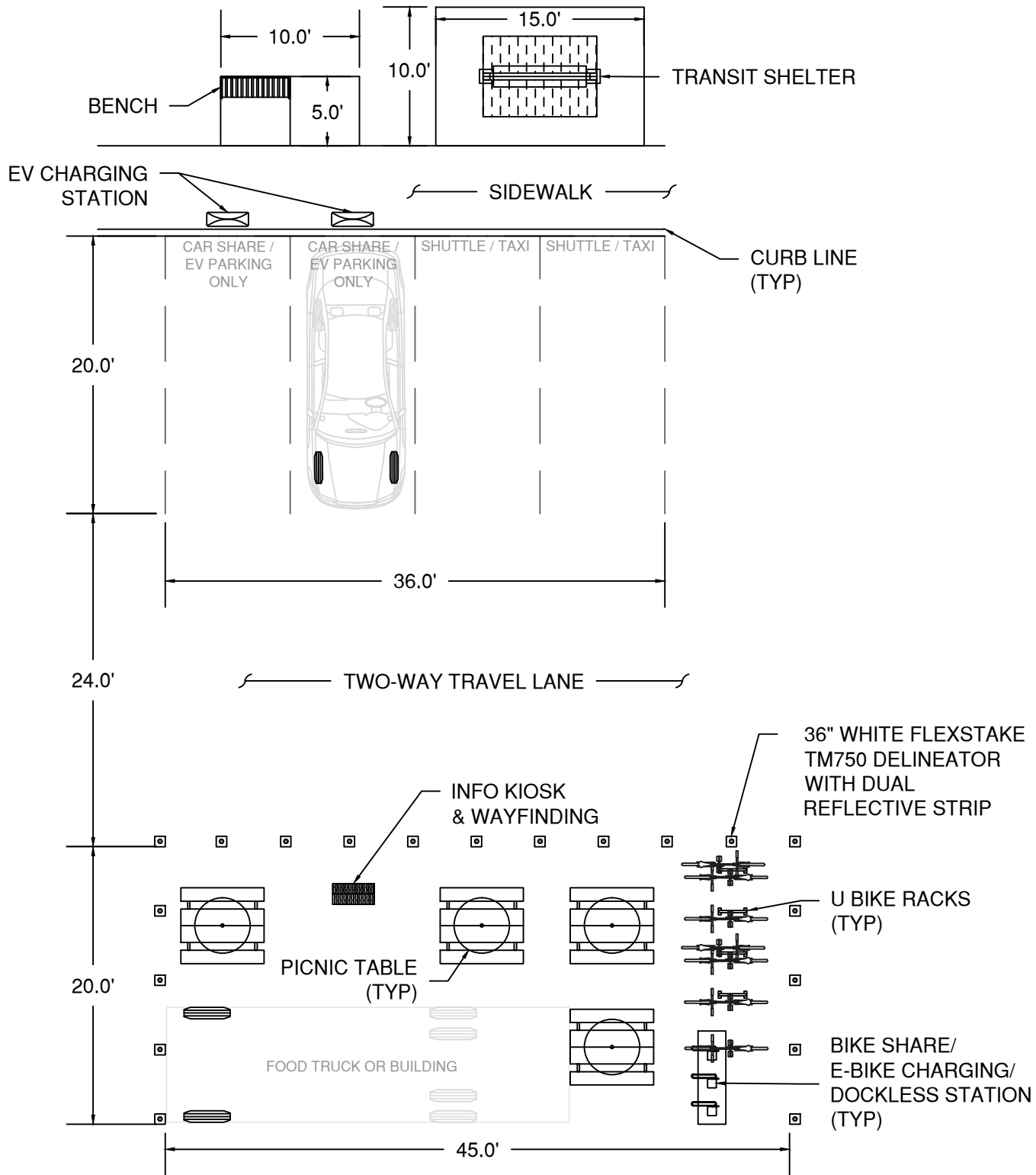

NOTES:

1. LOCATION & EXISTING CONDITIONS WILL DETERMINE LAYOUT
2. FINAL LAYOUT MUST MEET MINIMUM ADA STANDARDS FOR ACCESSIBLE DESIGN
3. ALL CONCEPTS SHOWN ARE FOR SPATIAL REPRESENTATION ONLY

DRAWN AJD	
DIV ROADWAY	
REV	DATE



CITY OF BEND
STANDARD DRAWING
710 NW WALL ST., BEND, OREGON 97701

MOBILITY POINTS - LARGE

SCALE NTS
DATE 11/01/2024
APPR
STD DWG R-50B